

ENGINEERING
TOMORROW

Danfoss

Whitepaper

Danfoss Hansen® multiplate system (Multi-FF)

Multiplate coupling device enables fast and reliable connection of hydraulic lines on mobile platforms



Contents

1	Executive summary	3
2	Pressure resistance - higher operating pressure to meet application requirement	3
3	Compact and lighter solution	3
4	Ergonomic design for ease of operation	4
5	Maintenance and serviceability	5
6	Cleanliness	5
7	Modular and flexible system design	6

Authors



Christian Kuenstel
Global Product Management
Leader, Connectors Business



Atul Puranik
Lead Engineer, EMEA, Danfoss
Power Solutions II



Sebastien Lafond
Global Engineering Leader,
Connectors Business

Executive summary

Danfoss has developed multiplate system (Multi-FF), a new quick disconnect coupling (QDC) device to facilitate connection of multiple hydraulic lines for power transmission. While this compact and light weight system extends benefits of Flat Face series coupling in terms of best in class flow rate and pressure resistance performance, modular and flexible design of Multi-FF system also allows customization to include specialized couplings for water or air transfer, or electrical connector as well.

A flat face quick disconnect coupling is a double shut-off style high performance QDC, where valving on both halves of coupling are flush facing with body. Multiplate device is further extension of coupling, which houses numerous QDC's in a set, and allows connection of all lines in single operation. Multiplate system device is primarily used on mobile equipment like tractor, wheel loader, excavator, sweeper, etc. where changing of attachments / implements is a frequent requirement.

In most of these equipment, different attachments come with two or three double acting hydraulic cylinders, to carry out various functions. In turn this means number hydraulic lines required to transmit power from equipment to attachment are 4 or 6. Connection of so many lines one-by-one using standalone QDC's become cumbersome for operator, requires significant time and is prone to cross-connection of lines. This is where easy and quick connection of all couplings in one go, without any special tools, becomes value for the customer.

Over the past few years, industry trend has been to offer compact machines, but with the same power and operating capabilities of their larger equivalents. In turn, this demands higher pressure resistance capability from hydraulic system components, with keeping size and weight of the component in check. Especially for mobile platforms, it is becoming necessity to make all sub-systems lighter and more compact. For hydraulic components used on mobile equipment developed for applications like agriculture and construction, rugged and dirty environment pose different challenges. In addition to satisfying higher pressure demands, engineers need to ensure that hydraulic components for such applications are robust and reliable enough for extended life, are protected from dust/dirt entering into hydraulic system, and are also easy to maintain / service in case of any malfunction in field. Further, for devices like multiplate coupling which are basically developed to improve operator comfort, human ergonomics, and safe operation of device are of prime importance.

Pressure resistance - higher operating pressure to meet application requirement

Danfoss' newly developed multiplate system (Multi-FF) caters to the pressure resistance requirements of various applications. While agriculture equipment's function typically at up to 250 bar (3625 psi) working pressure, rugged application platforms like in construction demand higher pressure resistance. For this very reason, Multi-FF is developed to withstand working pressure up to 350 bar (5075 psi), and few configurations are also optimally designed at 250 bar (3625 psi) which goes specially on agriculture equipment's. Even with such higher working pressure, factor of safety has not been compromised, and multiplate system (Multi-FF) has been developed with 4:1 factor of safety before fracture occurs.

With centralized locking system based on rack and pinion mechanism, Multi-FF is highly robust for pressure resistance. Multi-FF series coupling is also qualified for one million impulse cycles, at a factor of safety of 1.33 for pulsating pressure, to ensure resistance to fatigue failure when subjected to hydraulic shocks in application, and to provide reliable solution for extended service life.

Finite Element Analysis is extensively used to simulate and optimize each component of the system, which helps in ensuring robustness of the Multi-FF with maintaining compactness. All possible combinations of load incurring on multiplate system (Multi-FF) due to change spool position on equipment, is simulated in virtual environment and safety of the system has been ensured. Following images illustrate how stresses in all components were neutralized after series of simulations, which improved reliability of multiplate system.

Compact and lighter solution

As is the expectation from mobile platform OEM's, Multi-FF has been developed such that it occupies less space on equipment. Its internally mounted optimized guiding and locking mechanism, smartly arranged QDC's on plates, and optimally designed system components to meet the resistance requirement helps in keeping Multi-FF compact. In addition, rack and pinion based guiding mechanism facilitates effortless connection of QDC's, which in turn helps in keeping handle system shorter in length and contributes to compact package size.

Multi-FF system's core functionality is based on rack and pinion kinematics, where pinion is assembled in fixed plate and rotated through handle which translates rotary motion to linear motion (highlighted by blue arrows), and QDC's are connected. In contrast to cam and follower based multiplates, rack and pinion provides purely linear motion, without tilting the movable plate assembly, which makes it easy for connection of two sub-systems. Further, same components are used for centralized locking mechanism, through their non-teeth sections! As highlighted in second image (by red arrows), when couplings are pressurized in multiplate system (Multi-FF), top plate tends to get separated from bottom one, which transfers load to rack and in turn to pinion through a frictional Multi-FF contact. By using same components for guiding and locking, overall system size is maintained compact.

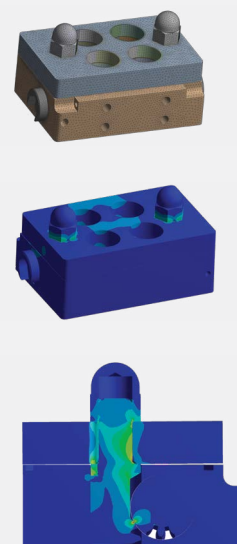

Ergonomic design for ease of operation

Ergonomics is all about man-machine interface and bringing machine to the man intuitively! For systems like Multi-FF which are developed to reduce human efforts, it is even more essential to ensure ease of operation. Danfoss' Multi-FF is developed with combination of features which takes care of human ergonomic and provides safe operation.

Handle position in both connected and disconnected state (start and end) is distinctive, and handle can be rotated through desired angle of 130° only. With this, operator does not have to maintain the handle in position manually while connecting top plate assembly with bottom one. Fixed handle positions, along with operating instructions marked on system make this very intuitive for operator. There is definite sound at the end of handle rotation to indicate complete connection of the

system. All these features are incorporated in small collar on right side of fixed plate, without affecting compactness or aesthetics of Multi-FF.

This collar encompasses elliptical grooves on its internal surface, which act as a guideway for pins assembled on fixed plate and maintains the rotation of handle in specified limit. The highlighted region of the groove is used for maintaining handle in disconnected state, with help on spring loaded pin. Specially designed profile at this region ensures handle does not fall down from its position, whereas handle rotation can be initiated for desired connection by exerting minor force on handle! Second groove on this collar performs function of a positive stop for handle rotation, and ensures that it

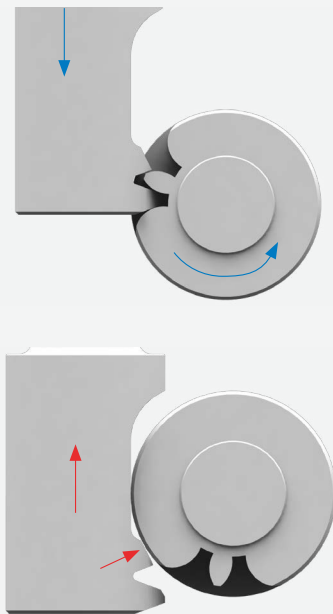

Various components in Multi-FF system like top and bottom plates, handle system parts are designed with aluminum material and only load bearing components are made in medium carbon steel in order to attain balance between performance and weight of the system. Especially for top plate sub-assembly which will typically be mounted on attachment side, and operator will handle manually for connection, being lighter in weight is important for operator comfort, and hence it is maintained under 2500 grams.

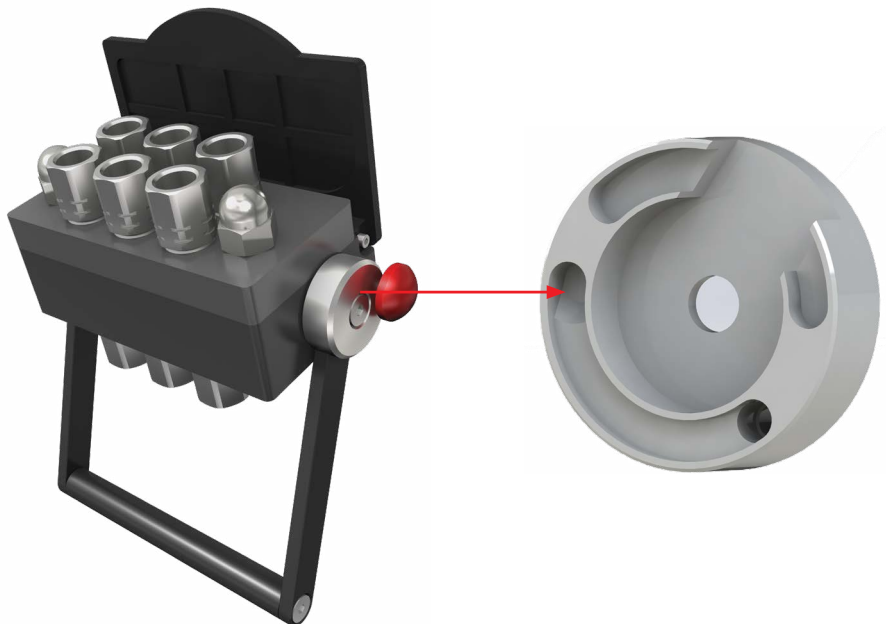

Multiplate system (Multi-FF) has been designed with two-layer safety mechanism to prevent any accidental disconnection of a system. At first, in connected state gear teeth on rack and pinion are disengaged as shows in earlier section. Because of this, even if pressure force tends to move top plate upward, pinion will not be rotated and in turn Multi-FF remains in connected state. Second, when Multi-FF is fully connected, spring loaded pin gets engaged in side collar, blocking any further rotation of handle. For disconnection of the system, one needs to simply push the red button on side face, which requires very less effort and rotate the handle in reverse direction. Red button is specially designed such that, there is no space to pull it mistakenly, or it does not pose any injury to operator. This whole mechanism also ensures that there no accidental disconnection of the Multi-FF system, adding to the safe operation.

One more important parameter for such systems to call ergonomically good is effort required to operate it. In terms of quick disconnect couplings this translates force to connect. Multi-FF system is designed such that it can be connected with significantly less force, compared to connection of standalone couplings. Further, the U-shape handle provides adequate grip to operator which adds to ease of operation.

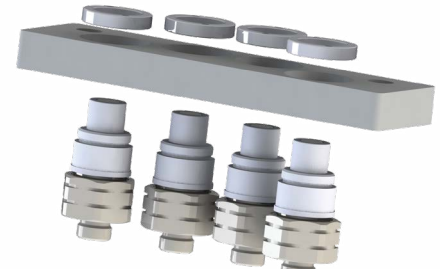

Force to connect comparison for 12FF

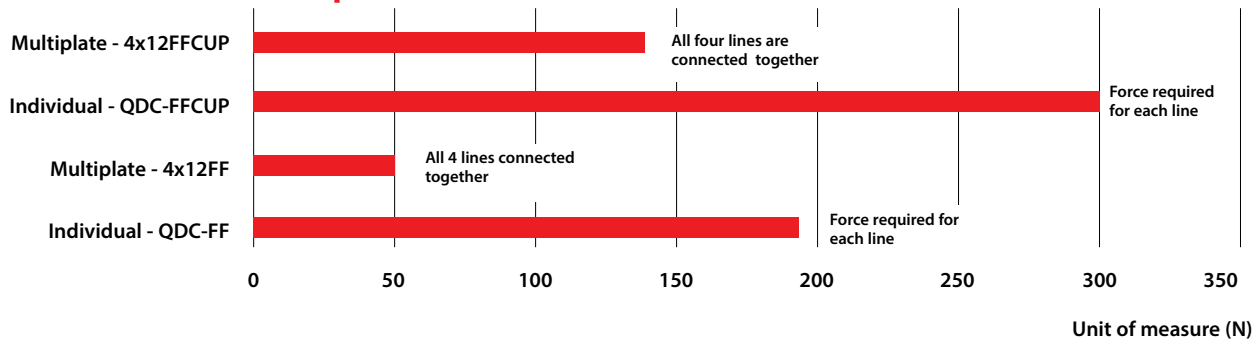

Maintenance and serviceability

Mobile machines are utilized all over the world in many different environments and all carry out varied tasks. They all have to minimize the downtime to ensure a decent return on investment. If a machine is 'out of order' there is a potential risk of missed deadlines and reduced profits. Hence in case of any component failure, quick maintenance or replacement of it, on field itself, becomes crucial to bring the machine up again. Keeping this in consideration, Danfoss' Multi-FF has been designed to offer greater serviceability. If one of the quick coupling on Multi-FF starts leaking / fails, one does not have to unmount Multi-FF from equipment. With use of standard tools, single coupling can be replaced in few seconds while Multi-FF is mounted on machine.

Cleanliness

Contamination is like an enemy of a hydraulic circuit! When entered in, it can degrade the functionality of any system component or even malfunction it. Hence it is required that utmost care is taken to ensure dust particles do not enter inside the hydraulic system. Danfoss' Multi-FF is developed such that its functionality is unaffected when used in dirty environment.

Multi-FF features dust cap for bottom plate, which houses all female halves of the coupling. This dust cap is designed to shut-off automatically when plates are disconnected, so that components are protected from contamination without human intervention. Sealing band has been installed on top surface of the plate which ensures dust particles do not enter the system, whether it is connected or in disconnected state. Further, all critical components for guiding and locking are arranged internal to system, and additional seals are installed on pinions to prevent dust entering from small clearances.

Overall, experimental study proved that even inexperienced operator can complete the connection of multiplate system (Multi-FF) in around 9 seconds, which is significantly lower when compared with time required to connect similar number of lines one-by-one.

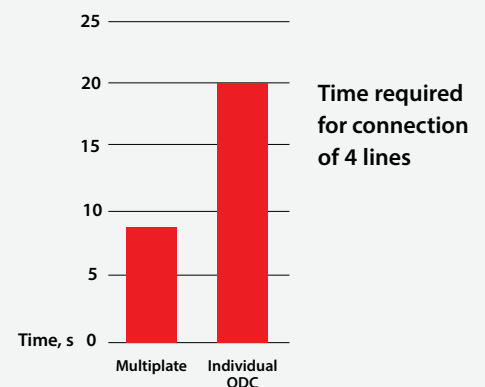

It is recommended that operator cleans the surfaces of couplings before connection. Use of flat face couplings in multiplate system (Multi-FF) makes it easier for cleaning, especially on bottom plate as couplings and surface of plate are flushing with each other. Additionally, flat face coupling itself helps in contamination free operation because of its flush face valving.

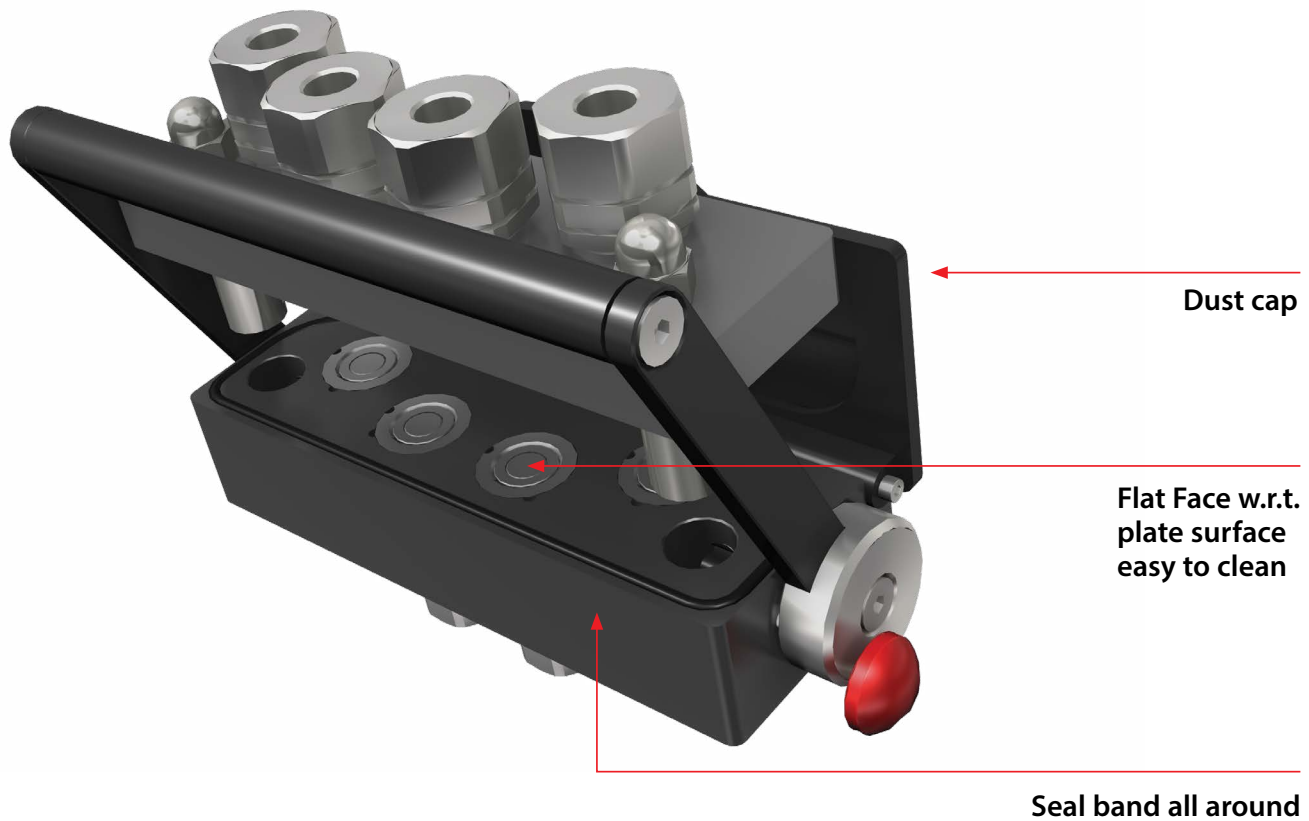

Modular and Flexible system design

While standalone QDC's are typically industry interchangeable, multiplate system (Multi-FF) is special one mainly due to varying requirements from OEM's, and hence customization is key for such product. Danfoss' multiplate system is developed to be hugely customizable to customer's specific needs. Multiplate system can be offered with an electrical connector for DC power transmission from equipment to attachment, with various number of contacts in each connector. In terms of couplings installed on multiplate system, specialized couplings for water or air transfer can also be provided as per application requirements, in addition to standard Flat Face (FF) series coupling. Additionally, integrated FF couplings are available in both carbon steel and stainless steel, and in different sealing and end connection options as per requirements.

Coupling arrangement in multiplate system can also be customized to best fit on equipment and in given space constraints. For example, QDC arrangement can be tweaked to make multiplate system longer in length but shorter in width, if there is a space constraint in one axis. Danfoss has also included one configuration in its standard offering, which can be directly assembled on DLM122 direction control valve, which eliminates need to hose assemblies on bottom plate.