



Tube Forming System  
**STAUFF Form EVO**

## Tube Fitting Technology by STAUFF

The STAUFF Connect portfolio is closely aligned with the market requirements and contains an extensive range of tube connectors made of carbon steel for metric tubes with outer diameters ranging from 4 to 42 mm in accordance with ISO 8434-1 / DIN 2353:

- 24° cutting ring fittings
- 24° taper fittings with O-ring
- 24° weld cones with O-ring
- 37° flared tube fittings

The product range is complimented by check and alternating valves for inline installation, thread reducers as well as blanking plugs and screws.

Special product types and sizes as well as alternative materials, material combinations and surface coatings deviating from the standards can be supplied on request.

Automated assembly machinery and hardened, wear-resistant tools enable the reliable assembly of tube connectors – both for series production in the workshop and on-site.

Because of its versatility and flexibility, the patented STAUFF Form tube forming system is undoubtedly the best solution for series production, in particular for applications with highest requirements with regards to safety, reliability and repeatability as well as process stability.

[www.stauff.com](http://www.stauff.com)



**24° Tube Fittings Overview**

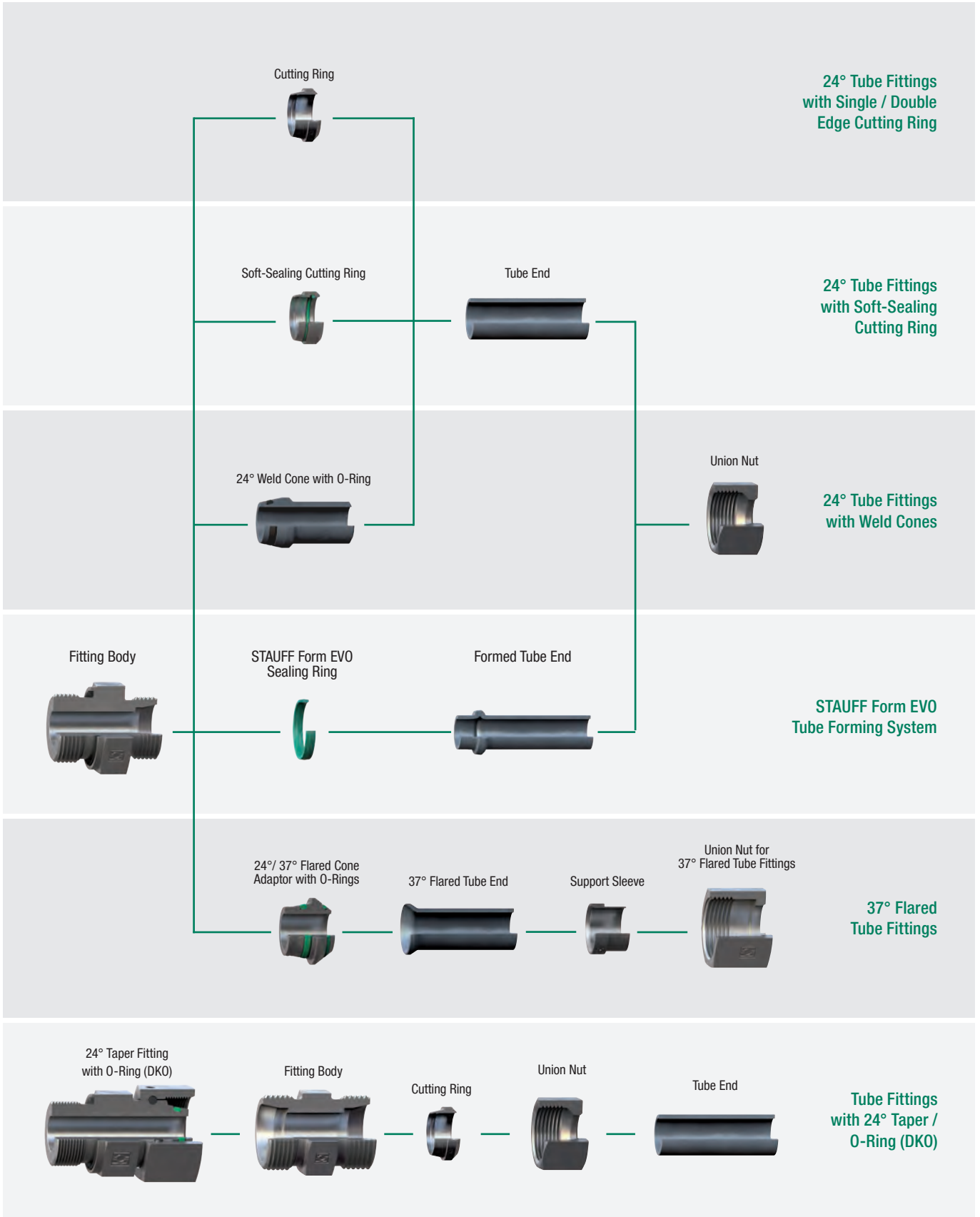

## STAUFF Form EVO Tube Forming System

### Performance

The STAUFF Form tube forming system was first presented in 2015. Since the beginning it has undoubtedly been one of the most efficient solutions available on the market for connecting metric tubes. In addition to its simplicity, it convinces with a high degree of safety, reliability and reproducibility.

With STAUFF Form EVO, STAUFF now presents the latest generation of the tube forming system, which is characterised by an increased level of efficiency and versatility as a result of continuous optimisation.

STAUFF Form EVO has been designed as standard for seamless cold-drawn precision steel tubes as well as stainless steel tubes with dimensions between 6 x 1.5 mm and 42 x 4 mm in the Light Series and between 6 x 1.5 mm and 38 x 6 mm in the Heavy Series. If required, parameters for alternative materials are available upon request and can be added by the manufacturer or via the optional cloud connection module integrated in the machines.

### System Design and Components

The system is based on standard parts and consists of only four key components:

The STAUFF Form EVO Sealing Ring is slid onto the tube end, which has previously been mechanically contoured. This creates a positive-locking connection that provides a reliable, permanent and maintenance-free seal when used with a conventional fitting body with 24° conical bore and a union nut, both according to ISO 8434-1.

### Versatility and Flexibility

Users benefit from the great versatility and flexibility of the system, as well as the many combination and adaptation options offered by using standard components from the STAUFF Connect product range.

There is therefore no need to duplicate the stock-keeping of similar components with a correspondingly high likelihood of confusion, as is often the case with comparable systems. Material and logistics costs can thus be correspondingly reduced.

### Materials and Surface Finishing

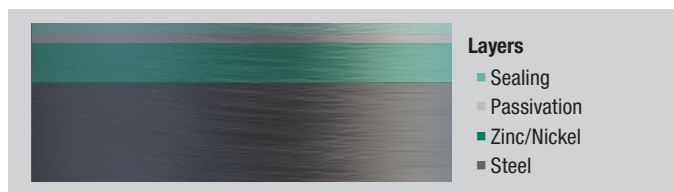

All components in the STAUFF Connect product range are designed as standard with a high-quality zinc/nickel surface coating.

With over 1,200 hours of resistance to red rust / base metal corrosion in the salt-spray chamber in accordance with DIN EN ISO 9227, the coating offers most reliable corrosion protection far beyond previously accepted market standards.

Even after shipping, handling and assembly of the components, the coating significantly exceeds the requirements for the highest corrosion protection class K5 defined in VDMA Standard Sheet 24576 for tube connectors.

### Sealing

The sealing of the only possible leakage path is provided primarily by the large-volume elastomeric sealing of the STAUFF Form EVO Sealing Ring which is specifically positioned between the surface of the tube and the 24° conical bore of the fitting body during assembly.

FKM (Viton®) is used as the standard sealing material and enables problem-free use of the STAUFF Form EVO tube forming system for challenging applications involving high temperatures or aggressive media.

Thanks to the combined metal-elastomer sealing, the usage of the system in low-temperature ranges down to -35° C is possible without restriction – as is also the case with NBR (Buna-N®).

The unique sealing profile has a particularly large cross-section in order to seal securely and permanently, even in the event of unfavourable tolerances of the tube or the tube fitting. Possible errors during assembly on the formed tube end are consistently avoided by the laterally equal profile of the sealing ring. The sealing effect is supported by the system pressure of the hydraulic system, so that the STAUFF Form EVO tube forming system is perfectly suited for high-pressure applications.

### Final Assembly in the Fitting Body

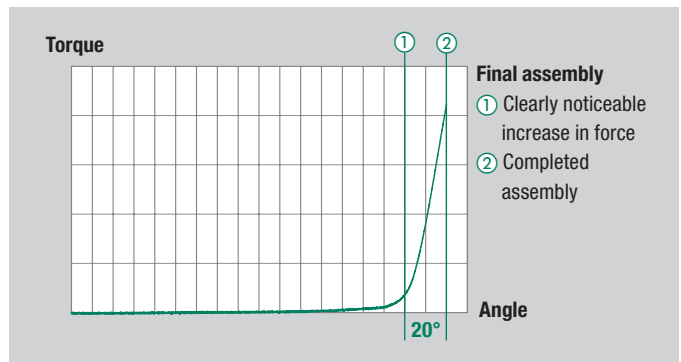

Final assembly is performed by tightening the union nut until the point with clearly noticeable increase in force (fixed point). The assembly is completed with another turn by approximately 15° to 20° beyond this point.

This incredibly simple assembly method has several benefits for the user:

- Considerably lower torques and short assembly paths (once the fixed point has been reached)
- Significant increase in torque to clearly indicate the end of the assembly
- Maximum safety to combat over-assembly
- No need for time-consuming and expensive training

Connections made with the STAUFF Form EVO can be untightened as often as required and reassembled without wear, as any damaging expansion of the 24° conical bore of the fitting body is technically avoided.

## STAUFF Form EVO Tube Forming System

### Pressure Resistance

When the STAUFF Form EVO tube forming system is used in conjunction with genuine products from the STAUFF Connect product range, it provides pressure resistance of up to 800 bar in the Heavy Series and 500 bar in the Light Series (generally with a four-fold safety factor and depending on the series, design and size of the fitting body and taking into consideration various pressure reducing factors).

This is the result of exceptional care taken in the development of the system and the selection, handling and processing of the raw materials.

Maximum tear-out strength can be guaranteed for the system due to the contour shaped at the tube end.

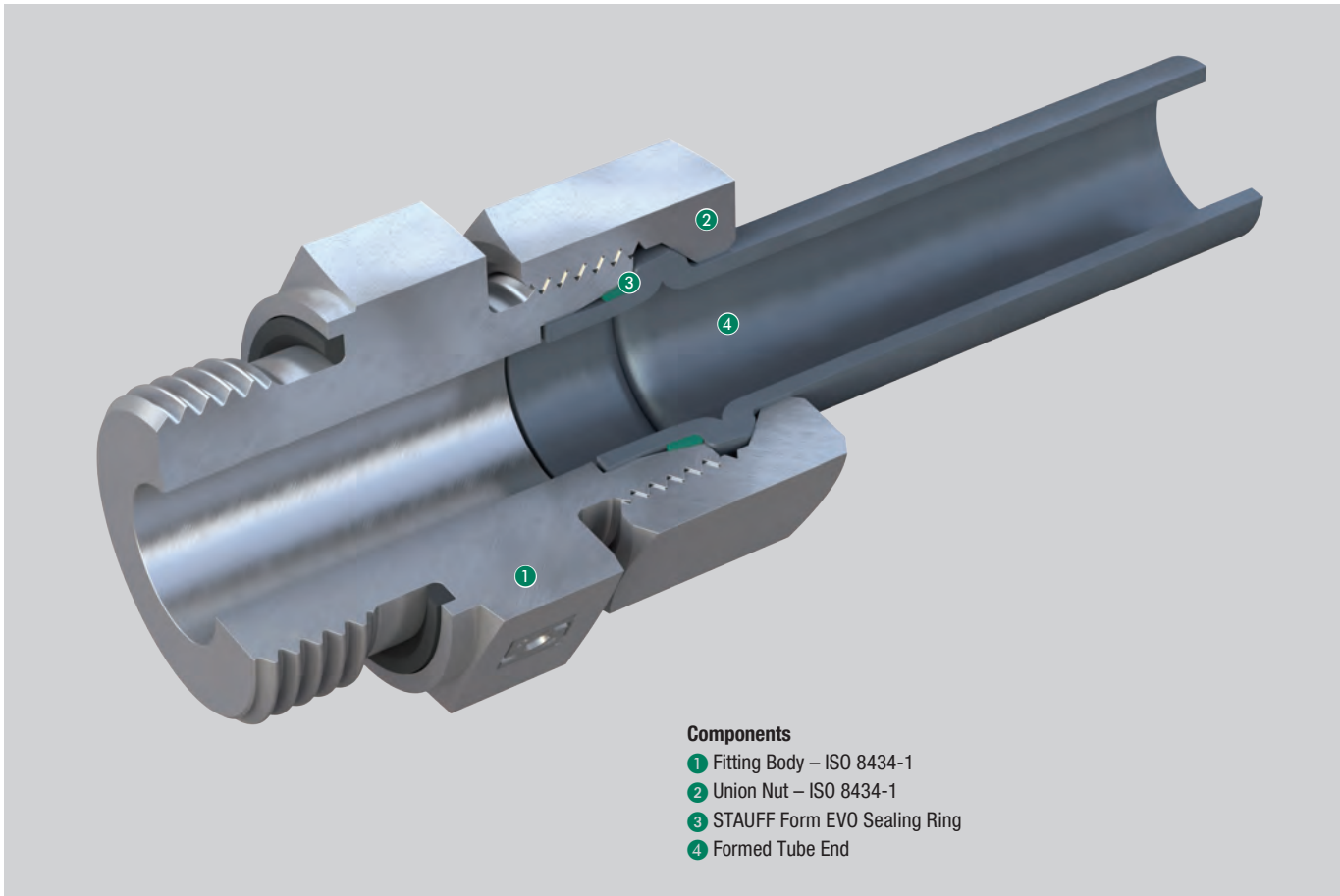
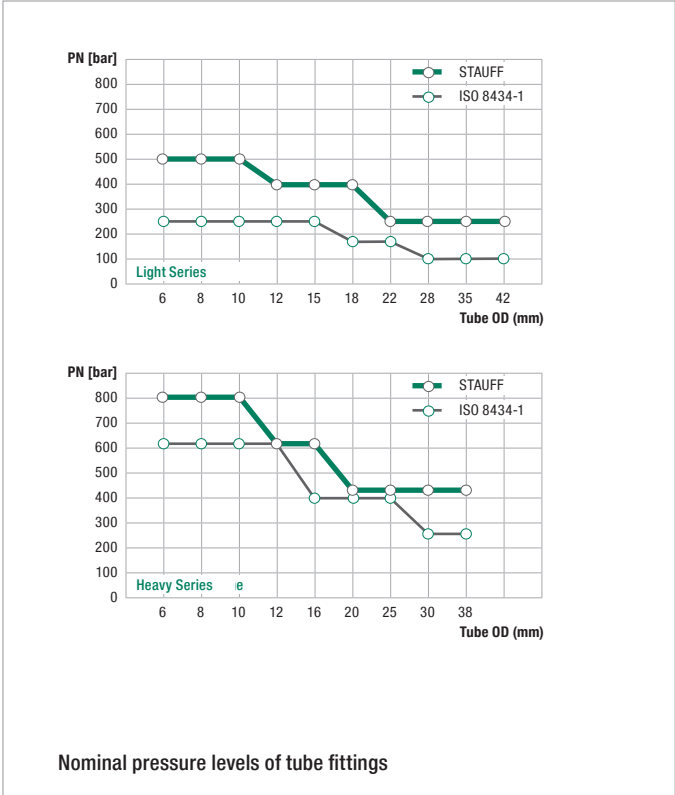

#### Components

- ① Fitting Body – ISO 8434-1
- ② Union Nut – ISO 8434-1
- ③ STAUFF Form EVO Sealing Ring
- ④ Formed Tube End



## At a glance – benefits of the STAUFF Form EVO Tube Forming System

### Design

- **Based on standard components including the standard union nut** of the STAUFF Connect product range according to ISO 8434-1 – **No duplicate storage** of similar stocking of similar components with a correspondingly high risk of confusion
- **Positive-locking connection with an elastomer sealing with a particularly large cross-section** to provide secure and permanent sealing even in the event of unfavourable tolerances
- **Sealing of the only possible leakage path primarily via the STAUFF Form EVO sealing ring** as well as the **secondary, face sealing**
- **Preservation of the flow behaviour through the optimised shape** of the formed tube end

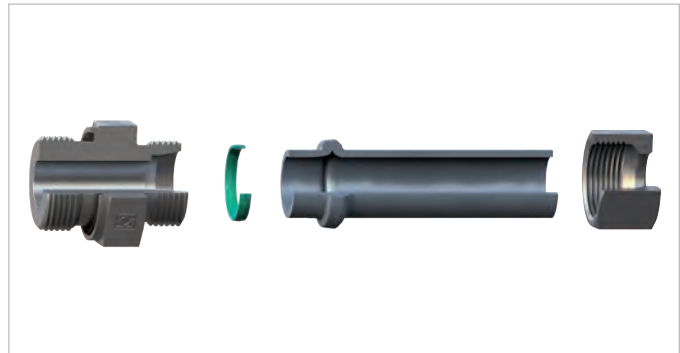

### Assembly Tools and Devices

- **Robust table-top device** for continuous operation in the workshop
- **High efficiency** of the system with **low cycle times**
- **Optimum tool concept** with exchangeable internal tube supports, so that only a **small number of tools is required** to cover all tube diameters
- **Intuitive operation via touchscreen**
- Optional **cloud connection** as well as **machine briefings and trainings**
- All **tools** needed for the forming process **clearly labelled** with the tube dimensions so that assembly errors caused by incorrect assignment can be largely ruled out
- **Short times required for tool changes** as clamping jaws, tube shaper and internal tube supports can be simply replaced without the need for any tools
- **Attractive maintenance packages** to ensure best possible service
- **Low insertion depths** compared to alternative systems for even more **complex tube geometries and smaller bending radii**

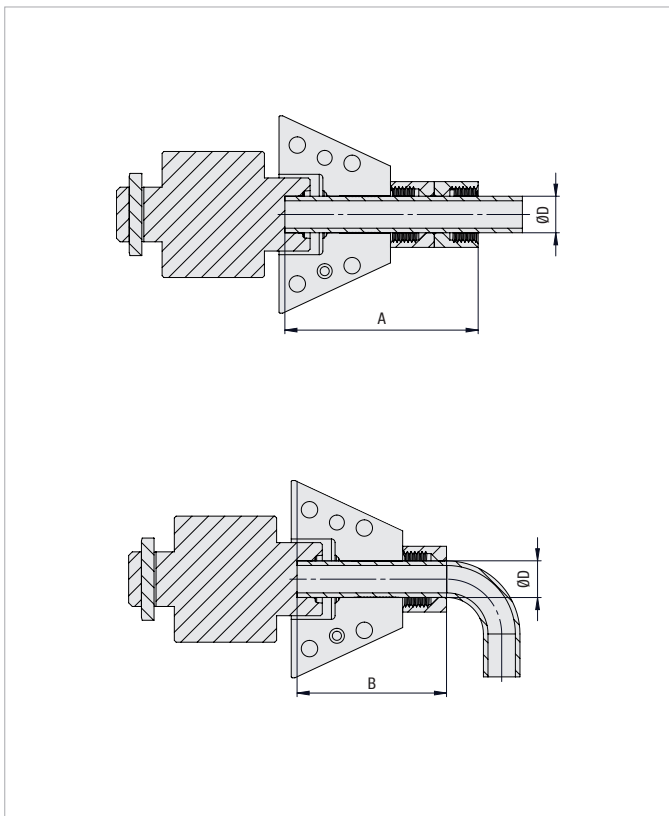

Series	Tube OD D mm	Minimum Length Straight Tube Ends A mm	Minimum Length Straight Sections next to Tube Bends B mm
L	6	75	52
	8	75	52
	10	74	52
	12	75	54
	15	89	66
	18	99	74
	22	106	82
	28	112	87
	35	138	106
	42	139	106
S	6	77	54
	8	77	54
	10	77	54
	12	78	56
	16	98	72
	20	115	84
	25	129	96
	30	148	111
	38	170	126

## At a glance – benefits of the STAUFF Form EVO Tube Forming System

### Durability and Application

- Suitable for both **steel and stainless steel** tubing as standard – also applicable for alternative tube materials on request
- Covers all common metric **tube dimensions from 6 x 1.5 mm to 42 x 4 mm** in the Light Series and **38 x 6 mm** in the Heavy Series respectively
- Suitable for **nominal pressures up to 800 bar** in the Heavy Series – designed with **four-fold safety and maximum tear-out strength**
- The use of **FKM (Viton®)** as the standard seal material makes the system perfect for the most challenging applications. Thanks to the combined metal-elastic seal, **low-temperature ranges down to -35° C** are possible without restriction
- High-quality zinc/nickel surface coating provides **maximum protection and corrosion resistance** – standard for all parts in the STAUFF Connect range



### Final Assembly

- **Incredibly simple final assembly in the fitting body** with low assembly torques as well as short assembly paths (once the fixed point has been reached) with a **minimised risk of over-assembly**
- Assembly errors are consistently avoided due to the **laterally identical profile of the sealing ring**
- Connections can be **untightened as often as required and reassembled** without wear, as any damaging expansion of the 24° conical bore of the fitting body is technically avoided
- **No need for time-consuming and expensive training**

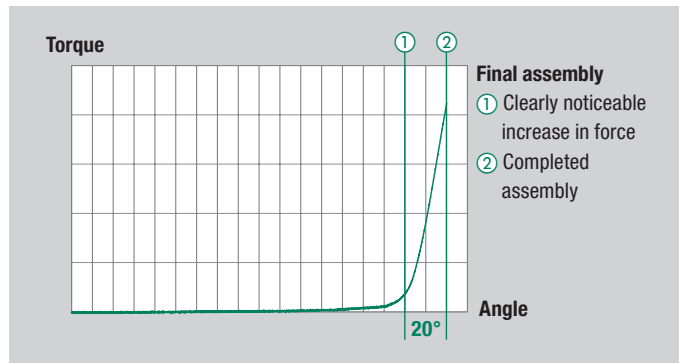

### Time and cost savings with the STAUFF Form EVO Tube Forming System

Assembly Times	Final Assembly Path	Connection Type	Component Costs
	120°	Welding	100 %
	15°-20°	STAUFF Form EVO	30-50 %
	30°	Cutting Ring	20-50 %
	90°-150°	Soft-Sealing Cutting Ring	50-80 %
	180°	Tube Flaring	80-120 %

**Key:**

- Tube Preparation
- Manual Welding Process and Machine-Assisted Assembly respectively
- Checking of the Assembly Results

## STAUFF Form EVO Tube Forming Machine Type SFO-F-A-A



### Product Description

The type SFO-F-A-A tube forming machine facilitates the economical and most reliable production of tube ends made of steel, stainless steel and other materials with a contour typical for the STAUFF Form EVO tube forming system.

The machine is designed as a robust table-top device for continuous operation in the workshop. It is used in connection with FI-FST tube shapers and FI-FB clamping jaws. Tube shapers with FI-ID internal tube supports are used with selected tube dimensions, which prevent the tube from being constricted in the shaping area.

Tube shapers, clamping jaws and internal tube supports have been specifically designed for the mechanical forming process and can be quickly and simply replaced without the need for any tools, if required. The resulting short tool change and set-up times contribute to the high efficiency of the system as well as ensuring low cycle times.

All the tools needed for the forming process are clearly labelled with the tube dimensions so that assembly errors caused by incorrect assignment can be largely ruled out.



Operating elements of the tube forming machine



Noise-reducing tool tray with durable rubber mat



Lateral handle bars and rubber machine feet with suitable clearance height



Open clamping head with clamping jaws inserted



Inserting the tube shaper into the tool holder – with no tools required



Electrical connections

## Optional Cloud connection allows preventive maintenance via remote access and facilitates the documentation of assembly processes Type SFO-F-IOT



Tube forming machines type SFO-F-A-A can be equipped at the factory with a built-in module for direct connection to a cloud operated by STAUFF. This solution is realised with an integrated SIM card which can be used in all industrial regions of the world.

This enables software updates, for example, without having to connect the machine to a local network on site. Parameter sets, which have been determined by STAUFF for non-standard tube materials can also be transferred quickly and directly to the machine in this way.

Customers are given access to the cloud via a protected online portal, where they can get detailed information on the assembly processes performed, among other things.

The required data security is guaranteed by encryption in both directions.



## STAUFF Form EVO Tube Forming Machine Type SFO-F-A-A

### Characteristics

#### Performance

- Constant high process safety, reliability and reproducibility by the position-control of the machine, which performs the shaping process following a manual start and monitors it by means of stored parameters
- Maximum efficiency thanks to short cycle times – ideal for series production
- Quick and simple replacement of tube shapers (with bayonet lock) and clamping jaws when changing the tube dimensions – with no tools required
- Potential risk of confusion and assembly errors caused by incorrect assignment can virtually be ruled out by the clear labelling of all assembly tools
- Surface-friendly clamping of the tube during the forming process
- Counters for lot/batch sizes and total quantities (separated by tool size)
- Predefined menu languages: English, German, French and Italian
- High degree of user comfort with clear information displayed on the operating panel

#### Design

- ① Robust and ergonomically designed machine housing
- ② Easily accessible clamping head for simple positioning of the clamping jaws and optimised assembly area with approx. 110 mm distance from the tube axis to the interfering edge of the machine housing, which allows processing of tubes with low bending radii or complex geometries
- ③ Noise-reducing tool tray with durable rubber mat
- ④ Lateral handle bars as attachment points for transport (e.g. with lifting belts)
- ⑤ Secure positioning thanks to flexible rubber machine feet
- ⑥ Type plate, with technical data, serial number, year of manufacture etc.

### Technical Data

#### Area of Application

- Function: Cold forming of seamless cold drawn precision steel tubes acc. to EN 10305-1 (materials E235, E355) and stainless steel tubes (material 1.4571 / AISI 316 Ti)

Parameters for alternative materials can be added by the manufacturer, if required. Please contact STAUFF for details.

- Operating principle: Tube forming with combined pressure/position-control
- Series and dimensions: Light Series (L): 6 x 1,5 mm to 42 x 4 mm  
Heavy Series (S): 6 x 1,5 mm to 38 x 6 mm

#### Dimensions / Weight

- Dimensions (W x D x H): 850 mm x 890 mm x 330 mm with lateral handle bars (detachable)
- Distance from the tube axis to the interfering edge of the machine housing: 110 mm
- Clearance height: 65 mm (height of the machine feet) enables simple and safe transport using a forklift or pallet jack
- Weight: 210 kg (including operating fluid, excluding forming tools)

#### Materials

- Machine frame: Aluminium
- Machine housing: Steel, painted
- Tool tray: NBR (Perbunan®)
- Machine feet: Natural rubber
- Form rings: Steel, zinc/nickel-plated
- Form rings (seal): FKM (Viton®)

#### Operating Elements

- ⑦ Operating panel for display and selection of all relevant settings and forming parameters
- ⑧ Button for definite confirmation of entries made on the operating panel
- ⑨ Status light to indicate readiness for operation and running assembly processes

#### Safety Devices

- ⑩ Main power switch (can be secured against unauthorised actuation when required)
- ⑪ Separate emergency stop button to immediately stop all machine movements

#### Connections (at the back of the machine)

- ⑫ Electrical connection according to IEC 60309 CEE 16A (cable length: 4 m)
- ⑬ Connection for External Foot Control Switch Type SFO/PRC-POC-FS
- ⑭ Ethernet connection (RJ45) for maintenance and data input by the manufacturer
- ⑮ Aerial IoT Gateway for preventive maintenance via remote access and facilitates the documentation of assembly processes

#### Tube Forming Tools

- ⑯ Clamping Jaws FI-FB with clear identification of the tube dimension
- ⑰ Version of a Tube Shaper FI-FST with Internal Tube Support FI-ID
- ⑱ Tube Shaper FI-FST with clear identification of the tube dimensions

#### Motor Configuration

- Power supply: 400 V AC @ 50 Hz - 3 phases  
460 V AC @ 60 Hz - 3 phases
- Current consumption: 2,55 A
- Connected load: 1,0 kW
- Electrical connection: Phase reversing plug according to IEC 60309 CEE 16A
- Cable length: 4 m

Alternative motor configurations and plug types are available on request. Please contact STAUFF for details.

#### Hydraulic System

- Operating fluid: Hydraulic oil Shell Tellus S2 MA 46 or equivalent (filled and ready for operation when delivered)
- Fluid volume: 6,1 litres
- Max working pressure: 700 bar

#### Operating Conditions

- Storage temperature: -10°C ... +70°C
- Ambient temperature: +15°C ... +35°C
- Ambient conditions: Dry, no condensing humidity, operation in horizontal position only less than 69 dB(A) as per EN ISO 11202 at full-load operation with maximum tube dimensions
- Noise emission:



#### STAUFF Maintenance Contracts

Please contact STAUFF for a maintenance contract, that provides optimum service for your STAUFF Tube Forming Machine.

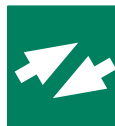

#### STAUFF Machine Rental

Please contact STAUFF for a rental machine and further details of what this service can offer.

**STAUFF Form EVO Tube Shapers ▪ Type FI-FST**  
**STAUFF Form EVO Internal Tube Supports ▪ Type FI-ID**



Tube OD mm	Tube Wall Thickness mm	Weight per piece kg ca.	Ordering Codes	
			Tube Shapers	
			Internal Tube Supports	
6	1,5	1,95	FI-FST-06L/S-F2-S-A	
8	1,5 2,0	1,97	FI-FST-08L/S-F2-S-A	
10	1,5 2,0 2,5 3,0	1,98	FI-FST-10L/S-F2-S-A	
12	1,5	1,99	FI-FST-12L/S-1.5-F2-S-A	
	2,0		FI-ID-12x1.5-HR/2	
	2,5			FI-FST-12L/S-2/2.5/3-F2-S-A
	3,0			
15	1,5	2,0	FI-FST-15L-F2-S-A	
	2,0		FI-ID-15x2.0-HR/2	
	2,5		FI-ID-15x2.5-HR/2	
16	2,0	2,04	FI-FST-16S-2/2.5-F2-S-A	
	2,5		FI-ID-16x2.0-HR/2	
	3,0		FI-ID-16x2.5-HR/2	
	4,0		FI-FST-16S-3/4-F2-S-A	
18	1,5	1,97	FI-FST-18L-2/2.5-F2-S-A	
	2,0			FI-ID-18x1.5-HR/2
	2,5			FI-ID-18x2.0-HR/2
	3,0		FI-ID-18x2.5-HR/2	
20	2,0	1,98	FI-FST-18L-3-F2-S-A	
	2,5		FI-FST-20S-2/2.5-F2-S-A	
	3,0		FI-ID-20x2.0-HR/2	
	4,0		FI-ID-20x2.5-HR/2	
22	2,0	1,95	FI-FST-20S-3/3.5/4-F2-S-A	
	2,5		FI-FST-22L-2/2.5-F2-S-A	
	3,0		FI-ID-22x2.0-HR/2	
	3,5		FI-ID-22x2.5-HR/2	
25	2,0	1,96	FI-FST-22L-3/3.5-F2-S-A	
	2,5		FI-FST-25S-2/2.5-F2-S-A	
	3,0		FI-ID-25x2.0-HR/2	
	3,5		FI-ID-25x2.5-HR/2	
	4,0		FI-FST-25S-3/3.5/4/5-F2-S-A	
	5,0			
28	2,0	1,96	FI-FST-25S-2/2.5-F2-S-A	
	2,5		FI-ID-28x2.0-HR/2	
	3,0		FI-ID-28x2.5-HR/2	
	3,5		FI-ID-28x3.0-HR/2	
	4,0		FI-FST-28L-3.5/4-F2-S-A	
30	2,5	1,95	FI-FST-28L-2/2.5/3-F2-S-A	
	3,0		FI-ID-30x2.5-HR/2	
	4,0		FI-ID-30x3.0-HR/2	
	5,0		FI-FST-30S-4/5/6-F2-S-A	
	6,0			
35	2,5	2,0	FI-FST-30S-2.5/3-F2-S-A	
	3,0		FI-ID-35x2.5-HR/2	
	4,0		FI-ID-35x3.0-HR/2	
	5,0		FI-FST-35L-4/5-F2-S-A	
38	3,0	1,82	FI-FST-35L-2.5/3-F2-S-A	
	4,0		FI-ID-38x3.0-HR/2	
	5,0		FI-ID-38x4.0-HR/2	
	6,0		FI-FST-38S-5/6-F2-S-A	
42	3,0	1,94	FI-FST-38S-3/4-F2-S-A	
	3,5		FI-ID-42x3.0-HR/2	
	4,0		FI-ID-42x3.5-HR/2	
			FI-ID-42x4.0-HR/2	

Materials / surface finishings: HR Steel, uncoated, hardened

Please note:

The selection chart is only applicable in conjunction with seamless cold drawn precision steel tubes according to EN 10305-1 (materials E235, E355) and stainless steel tubes (material 1.4571 / AISI 316 Ti).

Please consult STAUFF for information regarding the processing of tubes made from stainless steel and other materials.

**STAUFF Form EVO Clamping Jaws ▪ Type FI-FB**

Tube OD mm	Series	Weight per piece kg ca.	Ordering Codes
6	L / S	2,37	FI-FB-06L/S-F2-S-A
8	L / S	2,36	FI-FB-08L/S-F2-S-A
10	L / S	2,32	FI-FB-10L/S-F2-S-A
12	L / S	2,30	FI-FB-12L/S-F2-S-A
15	L	2,37	FI-FB-15L-F2-S-A
16	S	2,31	FI-FB-16S-F2-S-A
18	L	2,28	FI-FB-18L-F2-S-A
20	S	2,24	FI-FB-20S-F2-S-A
22	L	2,32	FI-FB-22L-F2-S-A
25	S	2,17	FI-FB-25S-F2-S-A
28	L	2,32	FI-FB-28L-F2-S-A
30	S	2,05	FI-FB-30S-F2-S-A
35	L	1,92	FI-FB-35L-F2-S-A
38	S	1,92	FI-FB-38S-F2-S-A
42	L	1,77	FI-FB-42L-F2-S-A

**Overview tube dimensions  
Parameter and Tools STAUFF Form EVO**
**Carbon Steel**

Size	Wallthickness								
	1	1,5	2	2,5	3	3,5	4	5	6
	E235/ E355	E235/ E355	E235/ E355	E235/ E355	E235/ E355	E235/ E355	E235/ E355	E235/ E355	E235/ E355
6	-	■	-	-	-	-	-	-	-
8	-	■	-	-	-	-	-	-	-
10	-	■	■	■	-	-	-	-	-
12	-	■	■	■	-	-	-	-	-
15	-	■	■	■	-	-	-	-	-
16	-	-	■	■	-	-	-	-	-
18	-	-	■	■	-	-	-	-	-
20	-	-	■	■	-	-	-	-	-
22	-	-	■	■	-	-	-	-	-
25	-	-	■	■	-	-	-	-	-
28	-	-	■	■	■	-	-	-	-
30	-	-	-	■	■	-	-	-	-
35	-	-	-	■	■	-	-	-	-
38	-	-	-	-	■	■	-	-	-
42	-	-	-	-	■	■	■	-	-

■ Parameter set and tools available. To use without tube supports.

**Stainless Steel**

Wallthickness	Size								
	1	1,5	2	2,5	3	3,5	4	5	6
	316ti	316ti	316ti	316ti	316ti	316ti	316ti	316ti	316ti
-	-	-	-	-	-	-	-	-	-
-	-	-	-	-	-	-	-	-	-
-	-	-	-	-	-	-	-	-	-
-	-	■	-	-	-	-	-	-	-
-	-	■	■	-	-	-	-	-	-
-	-	-	■	■	-	-	-	-	-
-	-	-	■	■	-	-	-	-	-
-	-	-	■	■	-	-	-	-	-
-	-	-	■	■	-	-	-	-	-
-	-	-	■	■	-	-	-	-	-
-	-	-	■	■	-	-	-	-	-
-	-	-	■	■	-	-	-	-	-
-	-	-	-	■	■	-	-	-	-
-	-	-	-	■	■	-	-	-	-
-	-	-	-	-	■	■	-	-	-
-	-	-	-	-	■	■	-	-	-

■ Parameter set and tools available. To use with internal tube supports.

**External Foot Control Switch**  
**Type SFO/PRC-POC-FS**



- Enables the operator to trigger assembly processes from a larger distance to the machine (cable length: 7 m)

**STAUFF Form EVO Oil**  
**Type Oel-Stauff-Form-1L**



- Enables faultless, mechanical tube forming with STAUFF Form EVO machines when using stainless steel tubes

**STAUFF Oil with brush**  
**Type SPR-PRC-H-M-OS**

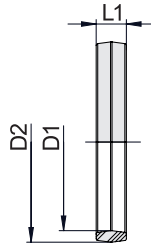

- Enables faultless, mechanical tube forming with STAUFF Form EVO machines when using stainless steel tubes

**STAUFF Form EVO Sealing Ring  
Type FI-FD • Series L / S**

Series	Tube OD mm D1	PN bar	Dimensions mm		Weight kg ca. per 100	Ordering Codes
			D2	L1		
L	6	500	7,8	2,6	0,01	FI-FD-06L/S-V90
	8	500	9,8	2,6	0,01	FI-FD-08L/S-V90
	10	500	12	2,8	0,02	FI-FD-10L/S-V90
	12	400	14	2,8	0,02	FI-FD-12L/S-V90
	15	400	17	2,8	0,03	FI-FD-15L-V90
	18	400	20	2,8	0,03	FI-FD-18L-V90
	22	250	24	2,8	0,04	FI-FD-22L-V90
	28	250	30	2,8	0,05	FI-FD-28L-V90
	35	250	37,8	3,4	0,10	FI-FD-35L-V90
	42	250	44,8	3,4	0,12	FI-FD-42L-V90
	S	6	800	7,8	2,6	0,01
8		800	9,8	2,6	0,01	FI-FD-08L/S-V90
10		800	12	2,8	0,02	FI-FD-10L/S-V90
12		630	14	2,8	0,02	FI-FD-12L/S-V90
16		630	18	2,8	0,03	FI-FD-16S-V90
20		400	22,6	3,4	0,05	FI-FD-20S-V90
25		400	27,6	3,4	0,07	FI-FD-25S-V90
30		400	32,8	3,4	0,09	FI-FD-30S-V90
38		400	40,8	3,4	0,11	FI-FD-38S-V90

Standard seal material is FKM (Viton®).

**Ordering Codes**
**\*FI-FD\*-15\*L\*-V90**

* STAUFF Form EVO Sealing Ring	FI-FD
* Outside Tube Diameter D1 (in mm)	-15
* Series	Light Series L Heavy Series S
* Seal Material	FKM (Viton®) 90 Shore -V90

Please contact STAUFF for alternative materials and surface finishings.



## STAUFF Form EVO Tube Forming Machine

### Quick Start Guide

Additional information and instructions on the operation of the tube forming machine can be found in the detailed operating manual.



Insert the tube shaper into the tool holder of the machine and use the bayonet lock to secure it.



Insert the clamping jaws into the clamping head of the machine and push them completely in until it stops.



Close the clamping head, push it into the machine and lock it by turning in clockwise direction.

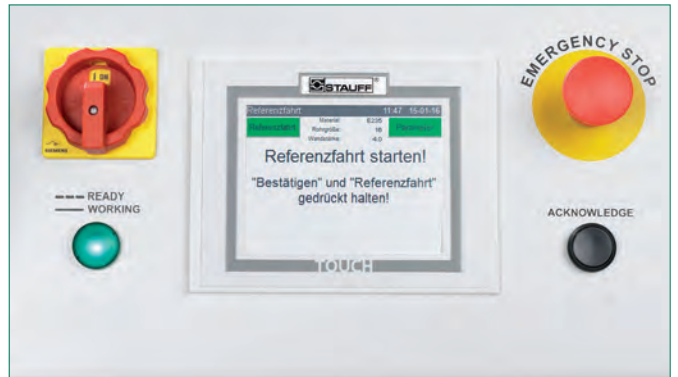

Use the operating panel and the Acknowledge button to start the reference movement.



Put the union nut FI-M onto the tube end. Pay attention to the correct alignment.



Gently slide the tube into the machine and push it in until it stops.



Use the operating panel to start the actual forming process.



Remove and visually check the formed tube end.

## Assembly Instructions for STAUFF Form EVO Tube Fittings

### Tube End Forming with a STAUFF Form Machine and Assembly with the Fitting Body

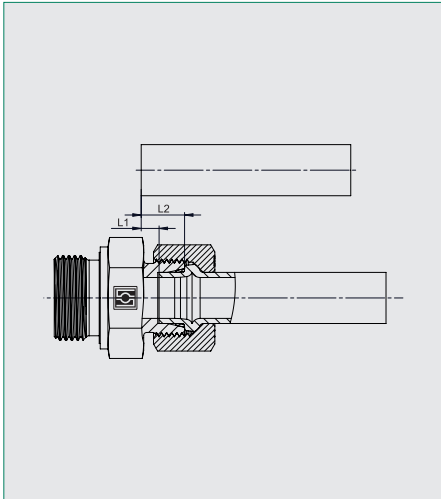
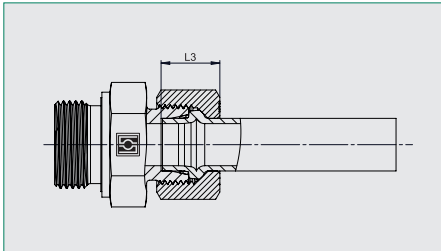
**Calculation Dimensions**

Tube OD mm	Tube Wall Thickness mm	L1 mm	L2 mm	L3 mm
6	1,5	7,3	13,8	14,6 (L+S)
8	1,5	7,5	14,0	14,6 (L+S)
	2,0	7,1	13,6	
10	2,5	6,6	13,1	14,5 (L) 15,5 (S)
	1,5	6,0	12,4	
	2,0	6,3	12,7	
	2,5	6,0	12,4	
12	3,0	5,7	12,1	14,6 (L) 15,6 (S)
	1,5	5,2	11,7	
	2,0	5,4	11,9	
	2,5	5,1	11,6	
15	3,0	4,9	11,4	15,6
	1,5	6	12,5	
	2,0	6,4	12,9	
16	2,5	6,4	12,9	18,4
	2,0	7,4	15,3	
	2,5	7,0	14,9	
	3,0	7,0	14,9	
18	4,0	6,2	14,1	16,4
	1,5	6,2	14,1	
	2,0	6,8	13,7	
	2,5	6,5	13,4	
	3,0	6,8	13,7	
20	4,0	6,4	13,3	21,6
	2,0	7,7	17,7	
	2,5	7,8	17,8	
	3,0	7,7	17,7	
22	4,0	7,3	17,3	17,5
	2,0	5,5	12,5	
	2,5	5,7	12,7	
	3,0	5,8	12,8	
25	3,5	5,9	12,9	24,5
	2,0	7,1	18,6	
	2,5	7,6	19,1	
	3,0	7,7	19,2	
	3,5	7,7	19,2	
	4,0	7,8	19,3	
28	5,0	7,8	19,3	18
	2,0	5,4	12,4	
	2,5	5,8	12,8	
	3,0	5,7	12,7	
30	3,5	5,3	12,3	27,2
	4,0	6,2	13,2	
	2,5	7,9	20,8	
	3,0	8,0	20,9	
	4,0	8,2	21,1	
	5,0	8,5	21,4	
35	6,0	8,2	21,1	22
	2,5	7,7	17,6	
	3,0	7,8	17,7	
	4,0	8,6	18,5	
38	5,0	8,7	18,6	31
	3,0	9,8	25,2	
	4,0	11,0	26,4	
	5,0	11,3	26,7	
42	6,0	11,4	26,8	22,7
	3,0	8,1	18,5	
	3,5	7,9	18,3	
	4,0	8,6	19,0	

## Assembly Instructions for STAUFF Form EVO Tube Fittings

### Tube End Forming with a STAUFF Form EVO Machine and Assembly with the Fitting Body

#### 1. Tube Preparation

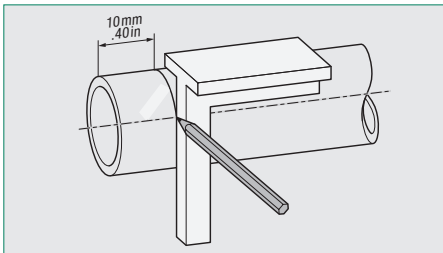

Saw off tube in right angle and at least 10 mm from the cut made by the tube manufacturer / supplier in order to avoid failures caused during shipment.

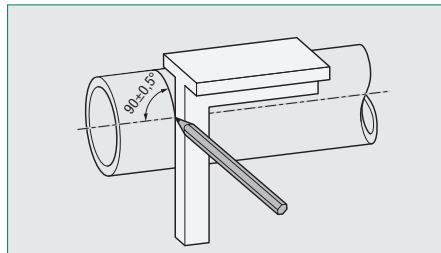

A maximum angular deviation / tolerance of  $\pm 0,5^\circ$  relative to the tube axis is permissible.

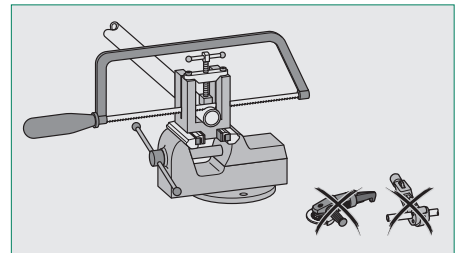

Only use proper tube sawing machinery or equipment. Do not use tube cutters or grinders as this may result in unwanted angled cuts and cause severe burring.

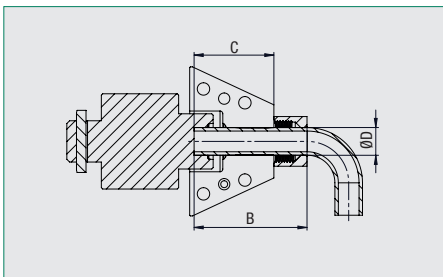
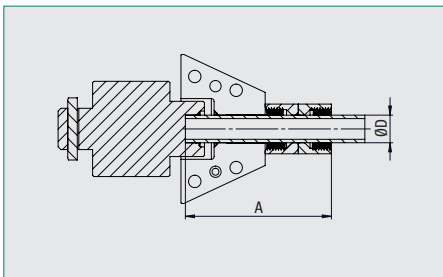

Series	Tube OD mm	Minimum Length A	Minimum Length B	Insertion Depth C incl. 10 mm Door thickness mm
		Straight Tube Ends mm	Straight Sections next to Tube Bends mm	
L	6	75	52	52
	8	75	52	52
	10	74	52	52
	12	75	54	54
	15	89	66	59
	18	99	74	67
	22	106	82	72
	28	112	87	75
	35	138	106	81
S	42	139	106	81
	6	77	54	54
	8	77	54	52
	10	77	54	52
	12	78	56	54
	16	98	72	61
	20	115	84	70
	25	129	96	79
	30	148	111	82
38	170	126	94	

Please note the minimum lengths for straight tube ends (dimension A) as well as for straight tube sections next to tube bends (dimension B) that are listed in the table.

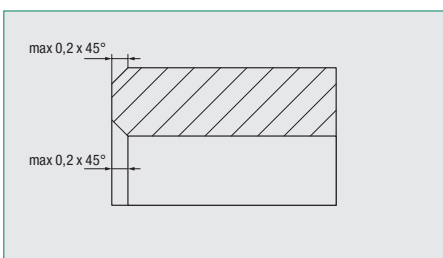

Slightly deburr inside and outside of the tube end (max 0,2 x 45°). The assembly area of the tube has to be free of contamination, chips and paint.



Please note: Improperly prepared and contaminated tubes will affect the service life of the connection and may result in leakage.

#### 2. Preparation and Machine-Assisted Tube Forming

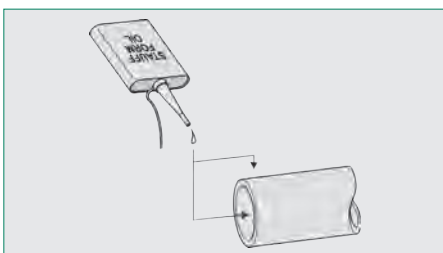

Lightly lubricate the inside and outside of the tube end (e.g. with a thin film of mineral-oil based hydraulic fluid HLP32) before starting the machine-assisted tube forming process. Do not use lubricating grease!

**Important: For tube ends made of stainless steel, always and only use original STAUFF Form EVO Oil. The use of any other fluid is not allowed and may result in damage of the assembly tools.**

Immediately proceed with the assembly in order to avoid exposure to contamination.

If the lubricant film on the outside of the tube end is too thick, fluid will be trapped between the forming tool and the tube end, thus resulting in inaccurate contours.

With regards to the actual tube forming process, please follow the detailed instructions in the operating manual of the machine.

## Assembly Instructions for STAUFF Form EVO Tube Fittings

### Tube End Forming with a STAUFF Form EVO Machine and Assembly with the Fitting Body

#### 3. Inspection

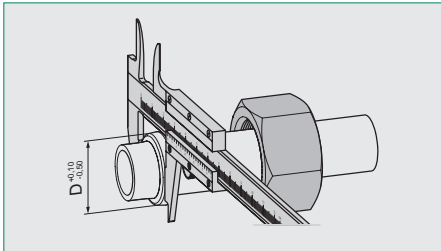

Use a suitable measuring device (caliper gauge) to check control diameter D of the formed tube end based on the dimension table on the right.

Series	Tube OD	Dimensions
	mm	D mm
L	6	9,5
	8	12,1
	10	14,0
	12	16,1
	15	20,1
	18	23,7
	22	27,1
	28	33,1
	35	42,1
	42	49,4
S	6	9,5
	8	12,1
	10	14,0
	12	16,1
	16	21,7
	20	26,1
	25	31,1
	30	37,1
	38	46,9

#### 4. Assembly with the Fitting Body

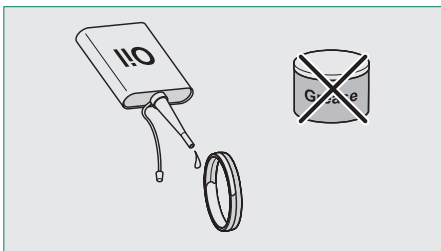

Lightly lubricate the inside and outside of the sealing element of the form ring (e.g. using mineral-oil based hydraulic fluid HLP32). Do not use lubricating grease!

Immediately proceed with the assembly in order to avoid exposure to contamination.

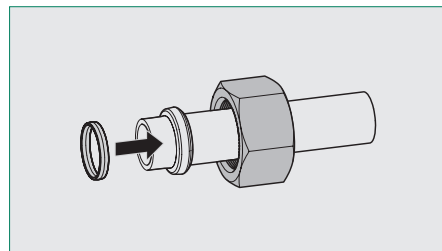

Slide the sealing ring onto the formed tube end (laterally identical profile to avoid assembly errors).

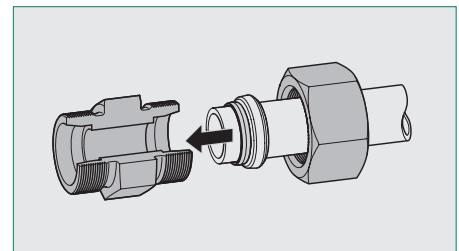

Carefully insert the formed tube end with the assembled sealing into the 24° taper of the fitting body.

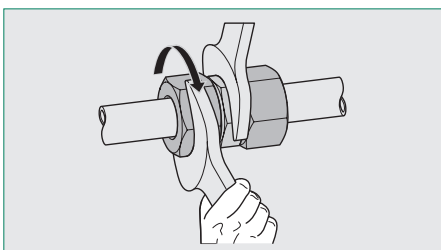

Use a suitable spanner to tighten the nut until there is a noticeable increase in force required (fixed point).

Avoid over-tightening by gripping the spanner close to the union nut.

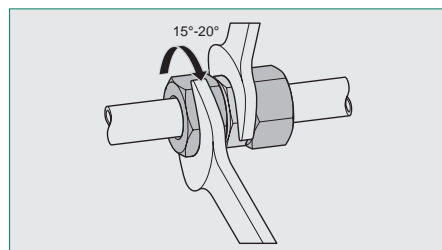

Finish the assembly by using a suitable spanner to tighten the union nut approximately 15°-20° beyond the fixed point. Always use a second spanner to hold the fitting body during the entire assembly procedure.

Alternatively, the assembly can be done via a torque.  
**Table with torques see point 6.**

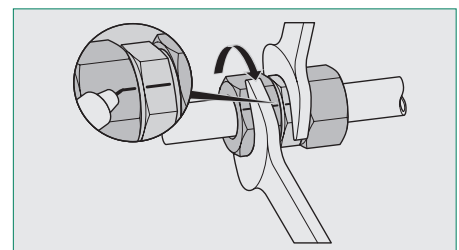

A marking line applied on the union nut and the fitting body makes it easier to indicate the sufficient tightening angle.



Please note when using stainless steel components: Thread and 45° cone of the union nut and thread of the fitting body grease with special stainless steel fitting grease or use a silver coated union nut.

#### 5. Repeated Assembly

For repeated assemblies, please follow the instructions from point 4 on.

## Assembly Instructions for STAUFF Form EVO Tube Fittings

Tube End Forming with a STAUFF Form EVO Machine and Assembly with the Fitting Body

### 6. Torques for alternative assembly for STAUFF Form EVO Tube Fittings

Series	Tube OD mm	Dimensions mm Thread	Turn till increase in force (fix point), than Assembly Angle	Torque N-m
L	6	M 12 x 1,5	15° ... 20°	23
	8	M 14 x 1,5		32
	10	M 16 x 1,5		40
	12	M 18 x 1,5		50
	15	M 22 x 1,5		65
	18	M 26 x 1,5		110
	22	M 30 x 2		120
	28	M 36 x 2		160
	35	M 45 x 2		275
	42	M 52 x 2		410
S	6	M 14 x 1,5		30
	8	M 16 x 1,5		40
	10	M 18 x 1,5		55
	12	M 20 x 1,5		60
	16	M 24 x 1,5		85
	20	M 30 x 2		160
	25	M 36 x 2		200
	30	M 42 x 2		270
	38	M52 x 2	400	