

EMEA Catalog

ENGINEERING  
TOMORROW

*Danfoss*

Danfoss Everflex hose and fittings  
solutions for your most **demanding applications**





## Everflex

Danfoss has been a pioneer in the production of hoses made with Teflon™ fluoropolymer. Everflex hoses are ideally suited for use in applications where high and low temperature, chemical resistance, low coefficient of friction, flexibility, and non-aging characteristics are required. Since 1961, Everflex has been the premier brand of hose products made from Teflon™ fluoropolymer for use in truck, chemical, hot melt, paper and pulp, hot presses, steam, packaging, paint, machinery, and many other demanding applications.

*Teflon™ is a trademark of The Chemours Company FC, LLC used under license by Danfoss Power Solutions II, LLC.*

# Everflex **hose and fittings**

## TABLE OF CONTENTS

<b>Application data</b>	<b>Section A</b>
Design considerations	A-4
Why Danfoss Everflex hose?	A-5
Warranty	A-6
Approvals and certifications	A-6
<b>Everflex smooth bore hose and fittings</b>	<b>Section B</b>
EN-TW series	B-8
EC-TW series	B-9
Crimp fittings	B-10
Field attachable fittings	B-14
<b>Everflex convoluted hose and fittings</b>	<b>Section C</b>
8000/8500 series	C-18
Conv-O-Crimp fittings	C-19
<b>Chemical resistance chart</b>	<b>Section D</b>
Danfoss Everflex hoses made with Teflon™ fluoropolymer	D-21

*Teflon™ is a trademark of The Chemours Company FC, LLC used under license by Danfoss Power Solutions II, LLC.*

APPLICATION DATA

**A**SMOOTH BORE HOSE  
AND FITTINGS**B**CONVOLUTED HOSE  
AND FITTINGS**C**

CHEMICAL RESISTANCE CHART

**D**



## Design **considerations**

Basic considerations in hose selection

### **Smooth bore vs. convoluted**

The primary differentiators between smooth and convoluted tubes are size and bend radius. Smooth bore hoses are generally only available in tube diameters of 26.9 mm or less, and they will have much greater minimum bend radii. For example, 26.9 mm smooth bore hose has a minimum bend radius of 228.6 mm while the same size convoluted hose has a minimum bend radius of only 76 mm. Convoluted hoses are also more resistant to collapse in vacuum. Smooth bore hoses tend to have a lower price than same-sized convoluted hoses.

### **Fittings**

Hoses made with Teflon™ fluoropolymer can use crimp or reusable fittings. The choice is largely one of individual preference, since there are no significant performance differences between the systems. The convoluted hoses use a crimp fitting with a special insert design and factory-installed Teflon™ fluoropolymer sleeve on the insert.

### **Conductive vs. non-conductive Teflon™ fluoropolymer**

Hoses, typically fuel lines carrying low-viscosity hydrocarbons at high flow rates, tend to build-up static electrical charges that can arc through the Teflon™ fluoropolymer to the braid. This can create a pinhole in the Teflon™ fluoropolymer. Specifying conductive Teflon™ fluoropolymer will allow the static charge to bleed off harmlessly to the fitting.

### **Braid material**

The 304 stainless is the baseline braid material for most hoses made with Teflon™ fluoropolymer. The 316 stainless is the recommended material for marine hose applications.

Teflon™ is a trademark of The Chemours Company FC, LLC used under license by Danfoss Power Solutions II, LLC.



## Why Danfoss **Everflex hose**?

- Everflex hose made from Teflon™ fluoropolymer has excellent temperature characteristics. It works well in high ambient, fluid, or gas media temperatures for smooth bore hose +260 °C (+500 °F) and for convoluted hose + 204 °C (+ 400 °F). It works equally well in cryogenic applications for smooth bore hose -73 °C (-100 °F) and for convoluted hose -54 °C (-65 °F).
- Everflex hose has a broad range of chemical resistance. It is inert to most commercial chemicals, acids, alcohols, coolants, elastomers, petroleum compounds, solvents, vinyl, synthetic lubricants, and hydraulic fluids.
- Everflex hose withstands continuous flexing, vibration, or impulse.
- Everflex hose is compatible with steam. It absorbs no moisture, hot or cold.
- Everflex hose is non-contaminating conveyed materials, fluids, or gases will not contaminate in service. It is easy to clean and sterilize for FDA or pharmaceutical applications.
- Everflex hose has high flow rates. Its low coefficient of friction with anti-stick properties insures continuous lower pressure drop during service with good pressure rating.
- Everflex hose resists deterioration. It is impervious to weather and can be stored for long periods of time without aging.
- Everflex hose has a long-life expectancy when applied within its temperature and pressure ratings.
- Everflex hose can handle many substances such as adhesives, asphalt, dyes, greases, glue, latex, lacquers, and paints. It has no carbon build-up when used as a compressor discharge line.

*Teflon™ is a trademark of The Chemours Company FC, LLC used under license by Danfoss Power Solutions II, LLC.*

# Application **data**

## Approvals and certifications

### Warranty

Danfoss hydraulics warranty policy is located at [www.danfoss.com](http://www.danfoss.com)

### Approvals and certifications

	<b>ABS</b>	<b>USCG</b>	<b>LR**</b>	<b>RINA**</b>	<b>DNV GL**</b>	<b>BV**</b>	<b>MED**</b>	<b>EN 45545***</b>
EN-TW	X		X	X	X	X	X	X
8000*		X						
ABS: American Bureau of Shipping								
USCG: US Coast Guard								
LR: Lloyd's Register of Shipping								
RINA: Registro Italiano Navale								
DNV GL: Det Norske Veritas Germanischer Lloyd								
BV: Bureau Veritas								
MED: Marine Equipment Directives								
EN 45545: European Railway Standards								

\* The listings above are intended only as guides in identifying which Aeroquip hoses comply with requirements of various agencies. For current and complete information, contact Danfoss.

\*\*Reduced working pressure S-10TW to 103 bar and S-12TW to 83 bar

\*\*\* EN 45545 class R23/HL1



## Everflex smooth bore **hose and fittings**

Everflex smooth bore hose made from Teflon™ fluoropolymer is specified in many of the most difficult applications across various industries. The extruded tube has excellent flex life, high temperature resistance, and chemical resistance. Additionally, Everflex hose is an excellent choice in applications requiring steam cleaning of an assembly or transfer of a highly viscous media, such as adhesives, paints, or food products.

The 304 stainless steel wire reinforcement provides the strength necessary to carry the working pressure and the durability to withstand harsh environments. The optional 316 stainless steel braid is ideal for more corrosive environments. High temperature hydraulic and pneumatic systems, such as those found in steel mills, foundries, and transit buses, are ideal locations to offer Everflex hose as a problem solver. Materials meet 21-CFR-177.1550 for use in food handling applications.

Teflon™ is a trademark of The Chemours Company FC, LLC used under license by Danfoss Power Solutions II, LLC.

# Danfoss EN-TW

Reduced, smooth bore PTFE hose  
Non-conductive (non-dissipating) PTFE hose



Part number	Hose I.D.		Hose O.D.		Working pressure		Min. burst		Min. bend	
	mm	in	mm	in	bar	psi	bar	psi	mm	in
EN-4TW	4.80	0.19	7.90	0.31	207	3,000	828	12,000	50	2.0
EN-5TW	6.40	0.25	9.80	0.39	207	3,000	828	12,000	75	3.0
EN-6TW	8.00	0.31	11.60	0.46	172	2,500	688	10,000	100	4.0
EN-7TW	9.60	0.38	13.00	0.51	155	2,250	620	9,000	125	5.0
EN-8TW	10.40	0.41	14.20	0.56	138	2,000	552	8,000	135	5.0
EN-10TW	12.80	0.50	16.40	0.65	103	1,500	412	6,000	165	6.5
EN-12TW	16.00	0.63	19.80	0.78	86	1,250	344	5,000	200	8.0
EN-14TW	19.10	0.75	23.30	0.92	75	1,100	300	4,400	230	9.0
EN-16TW	22.23	0.88	26.70	1.05	70	1,000	280	4,000	230	9.0
EN-18TW	25.40	1.00	28.80	1.17	70	1,000	280	4,000	300	12.0

Note: specifications in entire document are subject to change without notice

### Construction

- Non-conductive Teflon™ fluoropolymer inner tube
- One or two layers of stainless steel wire braid

### Applications

- Steam
- Compressor discharge
- Chemical transfer
- Meets SAE 100R14A

### Temperature range

- -73 °C to +260 °C  
(-100 °F to +500 °F)

### Crimp sockets

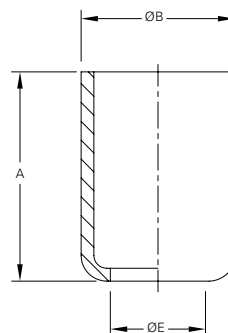

Part number	A	ØB	ØE
	mm	mm	mm
GH25848-4S	15.2	10.3	6.8
GH25848-5S	15.4	12.1	8.2
GH25848-6S	15.4	14.6	10
GH25848-8S	22.9	15.1	12.5
GH25848-10S	22.9	20.1	15.8
GH25848-12S	22.9	22.6	18.1
GH25848-16S	23.6	30.7	24.7

B

Teflon™ is a trademark of The Chemours Company FC, LLC used under license by Danfoss Power Solutions II, LLC.

**WARNING:** These hoses can be used to convey hazardous chemicals, steam, hot liquids, or other dangerous materials which can cause death, serious bodily injury including burns, pressure wounds, or chemical exposure if released accidentally. They should, therefore, only be handled or worked on by personnel properly trained in the safe handling of the materials or chemicals conveyed in the hoses.

Maximum negative pressure for -16 and larger are suitable for hose which has suffered no external damage or kinking. If greater negative pressures are required for -16 and larger hoses, the use of an internal support coil is recommended. Use of an internal support coil in -06 and larger hose is recommended for tube support where extended or continuous service at high temperature together with low or negative pressure is expected.



# Danfoss EC-TW

Reduced, smooth bore PTFE hose  
Conductive (static-dissipating) hose



Part number	Hose I.D.		Hose O.D.		Working pressure		Min. burst		Min. bend	
	mm	in	mm	in	bar	psi	bar	psi	mm	in
EC-4TW	4.80	0.19	7.90	0.31	207	3,000	828	12,000	50	2.0
EC-5TW	6.40	0.25	9.80	0.39	207	3,000	828	12,000	75	3.0
EC-6TW	8.00	0.31	11.60	0.46	172	2,500	688	10,000	100	4.0
EC-7TW	9.60	0.38	13.00	0.51	155	2,250	620	9,000	125	5.0
EC-8TW	10.40	0.41	14.20	0.56	138	2,000	552	8,000	135	5.0
EC-10TW	12.80	0.50	16.40	0.65	103	1,500	412	6,000	165	6.5
EC-12TW	16.00	0.63	19.80	0.78	86	1,250	344	5,000	200	8.0
EC-14TW	19.10	0.75	23.30	0.92	75	1,100	300	4,400	230	9.0
EC-16TW	22.23	0.88	26.70	1.05	70	1,000	280	4,000	230	9.0
EC-18TW	25.40	1.00	29.80	1.17	70	1,000	280	4,000	300	12.0

### Construction

- Conductive Teflon™ fluoropolymer inner tube
- One or two layers of 304 stainless steel wire braid provides a path to the hose end fittings for

### Applications

- Steam
- Compressor discharge
- Chemical transfer
- Meets 100R14B

### Temperature range

- -73 °C to +260 °C  
(-100 °F to +500 °F)

### Crimp sockets

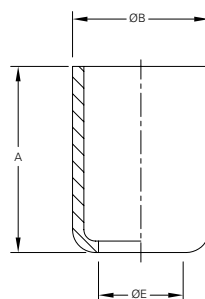

Part number	A	ØB	ØE
	mm	mm	mm
GH25848-4S	15.2	10.3	6.8
GH25848-5S	15.4	12.1	8.2
GH25848-6S	15.4	14.6	10
GH25848-8S	22.9	15.1	12.5
GH25848-10S	22.9	20.1	15.8
GH25848-12S	22.9	22.6	18.1
GH25848-16S	23.6	30.7	24.7

Teflon™ is a trademark of The Chemours Company FC, LLC used under license by Danfoss Power Solutions II, LLC.



WARNING: These hoses can be used to convey hazardous chemicals, steam, hot liquids, or other dangerous materials which can cause death, serious bodily injury including burns, pressure wounds, or chemical exposure if released accidentally. They should, therefore, only be handled or worked on by personnel properly trained in the safe handling of the materials or chemicals conveyed in the hoses.

"Z" designates a double braid of 304 stainless steel wire.

Maximum negative pressure for -16 and larger are suitable for hose which has suffered no external damage or kinking. If greater negative pressures are required for -16 and larger hoses, the use of an internal support coil is recommended. Use of an internal support coil in -06 and larger hose is recommended for tube support where extended or continuous service at high temperature together with low or negative pressure is expected.

# Crimp fittings

## For use with Everflex hose EN-TW and EC-TW

Standard plating available in Chrome III and additionally in Zi-Ni on customer request. Please contact Danfoss for Zi-Ni plating.

Universal metric female swivel light series, 24° and 60° cone, straight

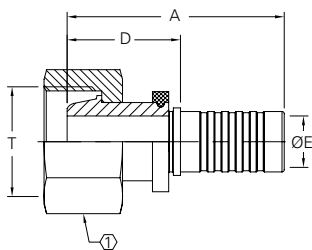

Part number	Socket number	ND	Hose size	A	D	øE	T	
				mm	mm	mm	TH'D	
GH15974-4	GH25848-4S	5	-04	36.2	21.2	3.2	M12x1,5	14
GH15974-5	GH25848-5S	6	-05	33.6	21.2	4.8	M14x1,5	17
GH15974-6	GH25848-6S	8	-06	35.4	23	6.3	M16x1,5	19
GH15974-8	GH25848-8S	10	-08	45.5	23	8.8	M18x1,5	22
GH15974-10	GH25848-10S	12	-10	47	24.5	11.1	M22x1,5	27
GH25848-12	GH25848-12S	16	-12	48	25.5	14.3	M26x1,5	32
GH15974-16	GH25848-16S	19	-16	50.5	28.1	16.1	M30x2	36

Note: Socket must be ordered separately

Universal metric female swivel light series, 24° and 60° cone, 45° elbow

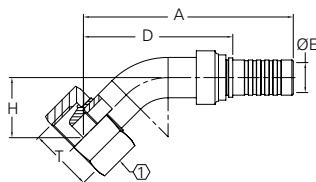

Part number	Socket number	ND	Hose size	A	D	øE	H	T	
				mm	mm	mm	mm	TH'D	
GH23053-4	GH25848-4S	5	-04	49.8	34.9	3.2	13.8	M12x1,5	14
GH23053-5	GH25848-5S	6	-05	55.5	43	4.5	16.8	M14x1,5	17
GH23053-6	GH25848-6S	8	-06	56.4	44	6	18.4	M16x1,5	19
GH23053-8	GH25848-8S	10	-08	67.8	45.4	8.6	18.6	M18x1,5	22
GH23053-10	GH25848-10S	12	-10	78	55.5	11	22.3	M22x1,5	27
GH23053-12	GH25848-12S	16	-12	80.1	57.6	14	24.6	M26x1,5	32
GH23053-16	GH25848-16S	19	-16	85.2	62.7	20.2	25.8	M30x2	36

Note: Socket must be ordered separately

Universal metric female swivel light series, 24° and 60° cone, 90° elbow

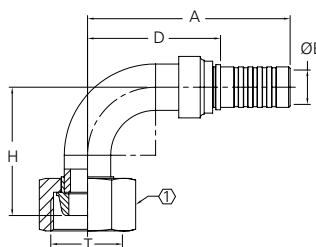

Part number	Socket number	ND	Hose size	A	D	øE	H	T	
				mm	mm	mm	mm	TH'D	
GH18887-4	GH25848-4S	5	-04	43	28.1	3.2	26.5	M12x1,5	14
GH18887-5	GH25848-5S	6	-05	45.5	33	4.5	30.5	M14x1,5	17
GH18887-6	GH25848-6S	8	-06	47	34.6	6.3	35	M16x1,5	19
GH18887-8	GH25848-8S	10	-08	60.5	38.2	8.6	37.5	M18x1,5	22
GH18887-10	GH25848-10S	12	-10	65.5	43	11	41.5	M22x1,5	27
GH18887-12	GH25848-12S	16	-12	74	51.5	14.3	53	M26x1,5	32
GH18887-16	GH25848-16S	19	-16	77	54.5	20.3	54	M30x2	36

Note: Socket must be ordered separately

# Crimp fittings

## For use with Everflex hose EN-TW and EC-TW

Standard plating available in Chrome III and additionally in Zi-Ni on customer request. Please contact Danfoss for Zi-Ni plating.

BSP female swivel, 60° cone, straight

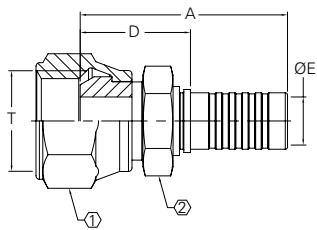

Part number	Socket number	ND	Hose size	A	D	øE	T	①	②
				mm	mm	mm	TH'D		
SH17909-4	GH25848-4S	5	-04	37.5	22.5	3.2	G 1/4"	17	12
SH17909-4-5	GH25848-5S	6	-05	35	22.5	4.8	G 1/4"	17	12
SH17909-6	GH25848-6S	8	-06	35.8	23.3	6.3	G 3/8"	22	17
SH17909-8	GH25848-8S	10	-08	47.3	24.8	8.8	G 1/2"	27	19
SH17909-10	GH25848-10S	12	-10	48	25.5	11.1	G 5/8"	27	22
SH17909-12	GH25848-12S	16	-12	48.3	25.8	14.3	G 3/4"	32	27
SH17909-16	GH25848-16S	19	-16	52.3	29.8	20.2	G 1"	41	30

Note: Socket must be ordered separately

BSP female swivel, 45° elbow

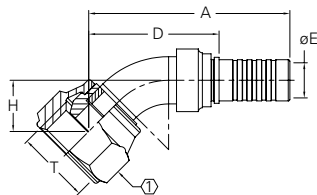

Part number	Socket number	ND	Hose size	A	D	øE	H	T	①
				mm	mm	mm	mm	TH'D	
SH18063-4	GH25848-4S	5	-04	46.7	31.7	3	12	G 1/4"	17
SH18063-4-5	GH25848-5S	6	-05	45.2	32.7	4.5	12	G 1/4"	17
SH18063-6	GH25848-6S	8	-06	49.3	36.9	6.3	14.4	G 3/8"	22
SH18063-8	GH25848-8S	10	-08	61.3	39	8.6	15.3	G 1/2"	27
SH18063-10	GH25848-10S	12	-10	64	41.5	11	16.3	G 5/8"	27
SH18063-12	GH25848-12S	16	-12	79.3	56.8	14.3	23.6	G 3/4"	32
SH18063-16	GH25848-16S	19	-16	101	78.5	20.2	32.5	G 1"	41

Note: Socket must be ordered separately

BSP female swivel, 90° elbow

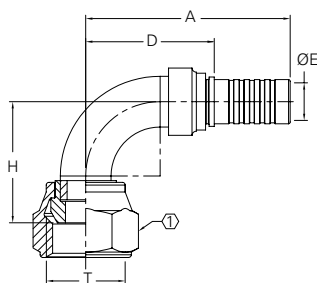

Part number	Socket number	ND	Hose size	A	D	øE	H	T	①
				mm	mm	mm	mm	TH'D	
SH17906-4	GH25848-4S	5	-04	40	25	3	22.2	G 1/4"	17
SH17906-4-5	GH25848-5S	6	-05	38.5	26	4.5	22.2	G 1/4"	17
SH17906-6	GH25848-6S	8	-06	43	30.6	6.3	28.5	G 3/8"	22
SH17906-8	GH25848-8S	10	-08	57	34.6	8.6	31.8	G 1/2"	27
SH17906-10	GH25848-10S	12	-10	60.5	38	11	36	G 5/8"	27
SH17906-12	GH25848-12S	16	-12	79	56.5	14.3	55.7	G 3/4"	32
SH17906-16	GH25848-16S	19	-16	92	69.5	20.2	69.2	G 1"	41

Note: Socket must be ordered separately

# Crimp fittings

## For use with Everflex hose EN-TW and EC-TW

Standard plating available in Chrome III and additionally in Zi-Ni on customer request. Please contact Danfoss for Zi-Ni plating.

### SAE 37° swivel

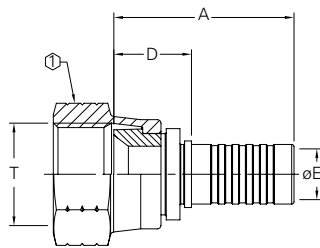

Part number	Socket number	ND	Hose size	A	D	øE	T	
				mm	mm	mm	TH'D	
GH19748-4	GH25848-4S	5	-04	28.2	13.3	3.2	7/16"-20 UNF	14
GH19748-5	GH25848-5S	6	-05	26.2	13.8	4.8	1/2"-20 UNF	17
GH19748-6	GH25848-6S	8	-06	27.2	14.8	6.3	9/16"-18 UNF	19
GH19748-8	GH25848-8S	10	-08	38.6	16.1	8.8	3/4"-16 UNF	22
GH19748-10	GH25848-10S	12	-10	39.5	17.1	11.1	7/8"-14 UNF	27
GH19748-12	GH25848-12S	16	-12	39	16.5	14.3	1 1/16"-12 UN	32
GH19748-16	GH25848-16S	19	-16	45.3	22.8	20.2	1 5/16"-12 UN	41

Note: Socket must be ordered separately

### SAE 37° swivel, 45° elbow

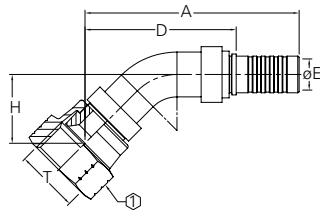

Part number	Socket number	ND	Hose size	A	D	øE	H	T	
				mm	mm	mm	mm	TH'D	
GH19750-4	GH25848-4S	5	-04	51.8	36.9	3.2	15.9	7/16"-20 UNF	14
GH19750-5	GH25848-5S	6	-05	49	36.5	4.5	15.6	1/2"-20 UNF	17
GH19750-6	GH25848-6S	8	-06	52.8	40.4	6.3	17.9	9/16"-18 UNF	19
GH19750-8	GH25848-8S	10	-08	65.7	43.3	8.6	19.7	3/4"-16 UNF	22
GH19750-10	GH25848-10S	12	-10	76.6	54.1	11.1	24.7	7/8"-14 UNF	27
GH19750-12	GH25848-12S	16	-12	88.1	65.6	14.3	29.3	1 1/16"-12 UNF	32
GH19750-16	GH25848-16S	19	-16	106.1	83.6	20.2	37.6	1 5/16"-12 UNF	41

Note: Socket must be ordered separately

### SAE 37° swivel, 90° elbow

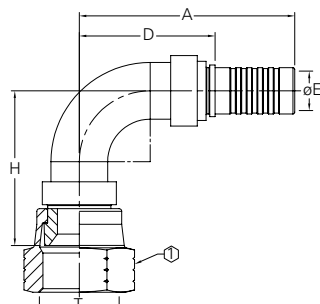

Part number	Socket number	ND	Hose size	A	D	øE	H	T	
				mm	mm	mm	mm	TH'D	
GH19752-4	GH25848-4S	5	-04	43	28	3.2	29.5	7/16"-20 UNF	14
GH19752-5	GH25848-5S	6	-05	40.5	28	4.5	29	1/2"-20 UNF	17
GH19752-6	GH25848-6S	8	-06	43	30.6	6.3	33.5	9/16"-18 UNF	19
GH19752-8	GH25848-8S	10	-08	57	34.7	8.6	38	3/4"-16 UNF	22
GH19752-10	GH25848-10S	12	-10	60.8	38.3	11.1	43.8	7/8"-14 UNF	27
GH19752-12	GH25848-12S	16	-12	68	45.5	14.3	50.5	1 1/16"-12 UNF	32
GH19752-16	GH25848-16S	19	-16	76.5	54	20.3	61	1 5/16"-12 UNF	41

Note: Socket must be ordered separately

# Crimp fittings

## For use with Everflex hose EN-TW and EC-TW

Standard plating available in Chrome III and additionally in Zi-Ni on customer request. Please contact Danfoss for Zi-Ni plating.

### 24° and 60° Globeseal™ swivel

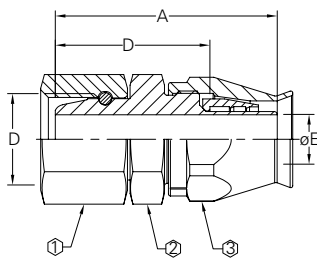

Part number	ND	Hose size	A	D	øE	T	①	②	③
			mm	mm	mm	TH'D			
07.046-4-4	5	-04	39	28.6	4	M12X1,5	14	14	9/16"
07.046-6-5	6	-05	39	28.6	5	M14X1,5	17	17	5/8"
07.046-8-6	8	-06	40	29.6	7	M16X1,5	19	19	11/16"
07.046-10-8	10	-08	43.6	30.3	9	M18X1,5	22	22	7/8"
07.046-13-10	12	-10	45.5	31.6	12	M22X1,5	27	27	1"
07.046-16-12	16	-12	52	38	14.7	M26X1,5	32	32	1 1/8"
07.046-22-16	19	-16	54	41.7	21	M30X2	36	36	1 3/8"

Note: Socket must be ordered seperately

### 24° and 60° Globeseal™ swivel, 45° elbow

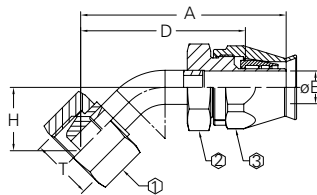

Part number	ND	Hose size	A	D	øE	H	T	①	②	③
			mm	mm	mm	mm	TH'D			
07.048-4-4	5	-04	49.2	38.8	4	15.2	M12X1,5	14	14	9/16"
07.048-6-5	6	-05	55.8	44.5	5.5	18.6	M14X1,5	17	17	5/8"
07.048-8-6	8	-06	59.5	48.2	7.1	20.5	M16X1,5	17	19	11/16"
07.048-10-8	10	-08	62.4	48.3	9.5	20.7	M18X1,5	22	22	7/8"
07.048-13-10	12	-10	76.5	61.8	12	25.8	M22X1,5	24	27	1"
07.048-16-12	16	-12	79.3	64.4	14.5	26.3	M26X1,5	27	32	1 1/8"
07.048-22-16	19	-16	87.7	74.6	21	29	M30X2	36	36	1 3/8"

Note: Socket must be ordered seperately

### 24° and 60° Globeseal™ swivel, 90° elbow

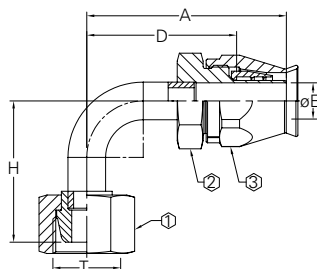

Part number	ND	Hose size	A	D	øE	H	T	①	②	③
			mm	mm	mm	mm	TH'D			
07.049-4-4	5	-04	41.4	31.1	4	26.5	M12X1,5	14	14	9/16"
07.049-6-5	6	-05	44	33.6	5.7	30.5	M14X1,5	17	17	5/8"
07.049-8-6	8	-06	48	37.6	7.2	35	M16X1,5	19	17	11/16"
07.049-10-8	10	-08	53	39.8	9.6	37.5	M18X1,5	22	22	7/8"
07.049-13-10	12	-10	60.5	46.6	12	41.5	M22X1,5	27	24	1"
07.049-16-12	16	-12	71.5	57.5	14.7	53	M26X1,5	32	27	1 1/8"
07.049-22-16	19	-16	76	65.2	21	54	M30X2	36	36	1 3/8"

Note: Socket must be ordered seperately

# Reusable fittings

For use with Everflex hose EN-TW and EC-TW

Millimetric standpipe, LD

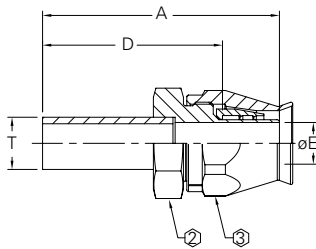

Part number	ND	Hose size	A	D	øE	T		
			mm	mm	mm	TH'D		
07.050-6-4	5	-04	48	37.6	4	6	14	9/16"
07.050-8-5	6	-05	47.5	37.2	5.5	8	17	5/8"
07.050-10-6	8	-06	48.5	38.2	7	10	17	11/16"
07.050-12-8	10	-08	54.5	41.4	9.5	12	22	7/8"
07.050-15-10	12	-10	57	43.2	12	15	24	1"
07.050-18-12	16	-12	59.5	45.4	14.5	18	27	1 1/8"
07.050-22-16	19	-16	63.5	51.2	21	22	36	1 3/8"

24° metric male, light duty

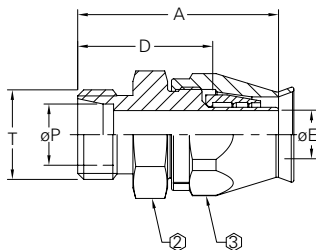

Part number	ND	Hose size	A	D	øE	T	øP		
			mm	mm	mm	TH'D	mm		
07.056-6-4	5	-04	36	25.6	4	M12X1,5	6	14	9/16"
07.056-8-5	6	-05	35.5	25.1	5.5	M14X1,5	8	17	5/8"
07.056-10-6	8	-06	36.5	26.1	7	M16X1,5	10	19	11/16"
07.056-12-8	10	-08	40	26.9	9.5	M18X1,5	12	22	7/8"
07.056-15-10	12	-10	43	29.1	12	M22X1,5	15	24	1"
07.056-18-12	16	-12	45.5	31.4	14.5	M26X1,5	18	27	1 1/8"
07.056-22-16	19	-16	49.5	37.2	21	M30X2	22	32	1 3/8"

Banjo

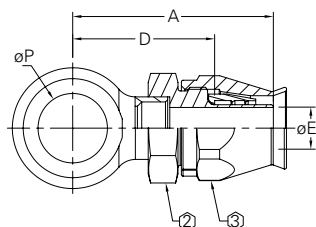

Part number	ND	Hose size	A	D	øE	øP		
			mm	mm	mm	mm		
07.051-4-4	5	-04	38.5	28.1	4	10.1	14	9/16"
07.051-6-5	6	-05	40.5	30.2	5.5	12.1	17	5/8"
07.051-8-6	8	-06	40.5	30.2	7	14.1	17	11/16"
07.051-10-8	10	-08	46	32.9	9.5	16.1	22	7/8"
07.051-13-10	12	-10	51	37.2	12	18.1	24	1"
07.051-16-12	16	-12	55	40.9	14.5	22.1	27	1 1/8"
07.051-20-16	19	-16	62.5	50.2	21	26.1	36	1 3/8"

# Reusable fittings

For use with Everflex hose EN-TW and EC-TW

## SAE 37° swivel

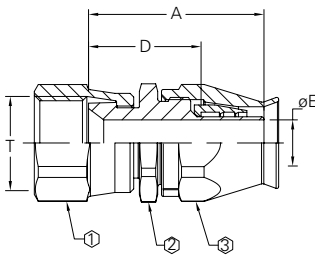

Part number	ND	Hose size	A	D	øE	T			
			mm	mm	mm	TH'D			
G190600-4	5	-04	29.6	19	4	7/16"-24 UNF	9/16"	9/16"	9/16"
G190600-5	6	-05	30	19.6	5.5	1/2"-20 UNF	5/8"	5/8"	5/8"
G190600-6	8	-06	31.2	20.8	7	9/16"-18 UNF	11/16"	11/16"	11/16"
G190600-8	10	-08	36.5	23.4	9	3/4"-16 UNF	7/8"	7/8"	7/8"
G190600-10	12	-10	40	26.2	12	7/8"-14 UNF	1"	1"	1"
G190600-12	16	-12	42.1	28	14.5	1 1/16"-12 UNF	1 1/4"	1 1/4"	1 1/8"
G190600-16	19	-16	45.6	33.2	21	1 5/16"-12 UNF	1 1/2"	1 1/2"	1 3/8"

## Male pipe

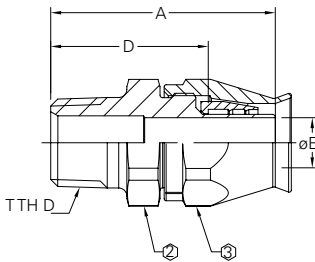

Part number	ND	Hose size	A	D	øE	T		
			mm	mm	mm	TH'D		
G190627-2-4	5	-04	33.5	22.9	4	1/8"-27 NPTF	9/16"	9/16"
G190627-4-4	5	-04	38.1	27.5	4	1/4"-18 NPTF	9/16"	9/16"
G190627-4-5	6	-05	37.9	27.5	5.5	1/4"-18 NPTF	5/8"	5/8"
G190627-4-6	8	-06	39.5	29.4	7	1/4"-18 NPTF	11/16"	11/16"
G190627-6-6	8	-06	39.5	29.1	7	3/8"-18 NPTF	11/16"	11/16"
G190627-8-6	8	-06	44.3	33.9	7	1/2"-14 NPTF	7/8"	11/16"
G190627-6-8	10	-08	43.1	48.2	9.6	3/8"-18 NPTF	7/8"	7/8"
G190627-8-10	12	-10	51.5	37.4	12	1/2"-14 NPTF	1"	1"
G190627-12-12	16	-12	55.2	41.1	14.5	3/4"-14 NPTF	1 1/8"	1 1/8"
G190627-16-16	19	-16	60.1	47.7	21	1-11 1/2" NPTF	1 3/8"	1 3/8"

## BSP female swivel

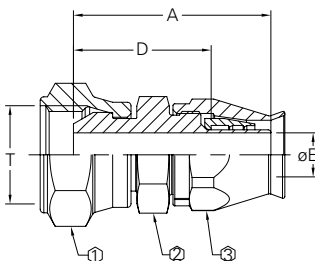

Part number	ND	Hose size	A	D	øE	T			
			mm	mm	mm	TH'D			
07.022-4-4	5	-04	37	26.5	4	G 1/4"	17	17	9/16"
07.022-6-6	8	-06	38	27.6	7	G 3/8"	22	22	11/16"
07.022-8-8	10	-08	43	31.3	9.5	G 1/2"	27	27	7/8"
07.022-10-10	12	-10	45.5	31.5	12	G 5/8"	27	27	1"
07.022-12-12	16	-12	50	36	14.5	G 3/4"	32	32	1 1/8"
07.022-16-16	19	-16	52	39.5	21	G 1"	41	41	1 3/8"

# Reusable fittings

For use with Everflex hose EN-TW and EC-TW

BSP female swivel, 45° elbow

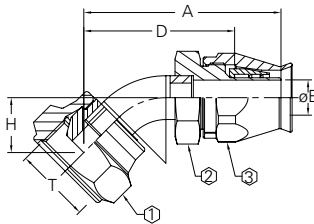

Part number	ND	Hose size	A	D	øE	H	T	1	2	3
			mm	mm	mm	mm	TH'D			
07.633-4-4	5	-04	46.5	36	4	12	G 1/4"	17	14	9/16"
07.633-6-6	8	-06	50.5	40.1	7	14.5	G 3/8"	22	17	11/16"
07.633-8-8	10	-08	54	42.3	9.5	15	G 1/2"	27	22	7/8"
07.633-10-10	12	-10	59	45	12	16.5	G 5/8"	27	24	1"
07.633-12-12	16	-12	75.5	61.5	14.5	22.5	G 3/4"	32	27	1 1/8"
07.633-16-16	19	-16	100	87.5	21	32.5	G 1"	41	36	1 3/8"

BSP female swivel, 90° elbow

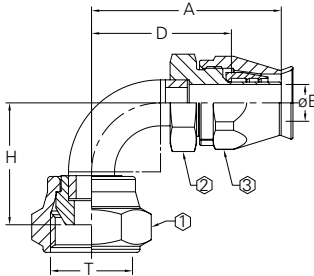

Part number	ND	Hose size	A	D	øE	H	T	1	2	3
			mm	mm	mm	mm	TH'D			
07.339-4-4	5	-04	38.5	28	4	22.2	G 1/4"	17	14	9/16"
07.339-6-6	8	-06	44	23	7	28.5	G 3/8"	22	17	11/16"
07.339-8-8	10	-08	49.5	25.1	9.5	31.8	G 1/2"	27	22	7/8"
07.339-10-10	12	-10	55.5	28.7	12	36	G 5/8"	27	24	1"
07.339-12-12	16	-12	76.5	48	14.5	55.7	G 3/4"	32	27	1 1/8"
07.339-16-16	19	-16	91	78.5	21	69.2	G 1"	41	36	1 3/8"

BSP male parallel

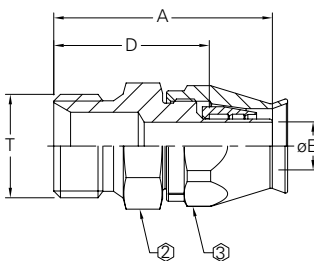

Part number	ND	Hose size	A	D	øE	T	2	3
			mm	mm	mm	TH'D		
07.180-4-4	5	-04	37.5	27	4	G 1/4"	14	9/16"
07.180-6-6	8	-06	38.5	28.1	7	G 3/8"	19	11/16"
07.180-8-8	10	-08	44	32.3	9.5	G 1/2"	22	7/8"
07.180-10-10	12	-10	49	35	12	G 5/8"	24	1"
07.180-12-12	16	-12	52.5	38.5	14.5	G 3/4"	32	1 1/8"
07.180-16-16	19	-16	56	43.5	21	G 1"	36	1 3/8"



## Everflex convoluted **hose and fittings**

Everflex Conv-O-Crimp 8000 and 8500 series hose provides excellent performance, reliability, and durability with tighter bend radii than smooth wall hose. When compared with large diameter rubber hose, Conv-O-Crimp is dramatically lighter weight, more flexible, and more resistant to heat and chemicals. The tube is fabricated with tape of Teflon™ fluoropolymer and reinforced with 304 stainless steel wire. The result is a product ideally suited for applications

in truck and bus, chemical processing, food processing, hydraulics, pharmaceutical, tire manufacturing, steel mills, and many others. In addition to the standard 8000 series virgin white tube of Teflon™ fluoropolymer, the 8500 series has an internal conductive static dissipating black liner that provides a path to the hose end fitting for applications where flow induced, electrostatic charges can occur.

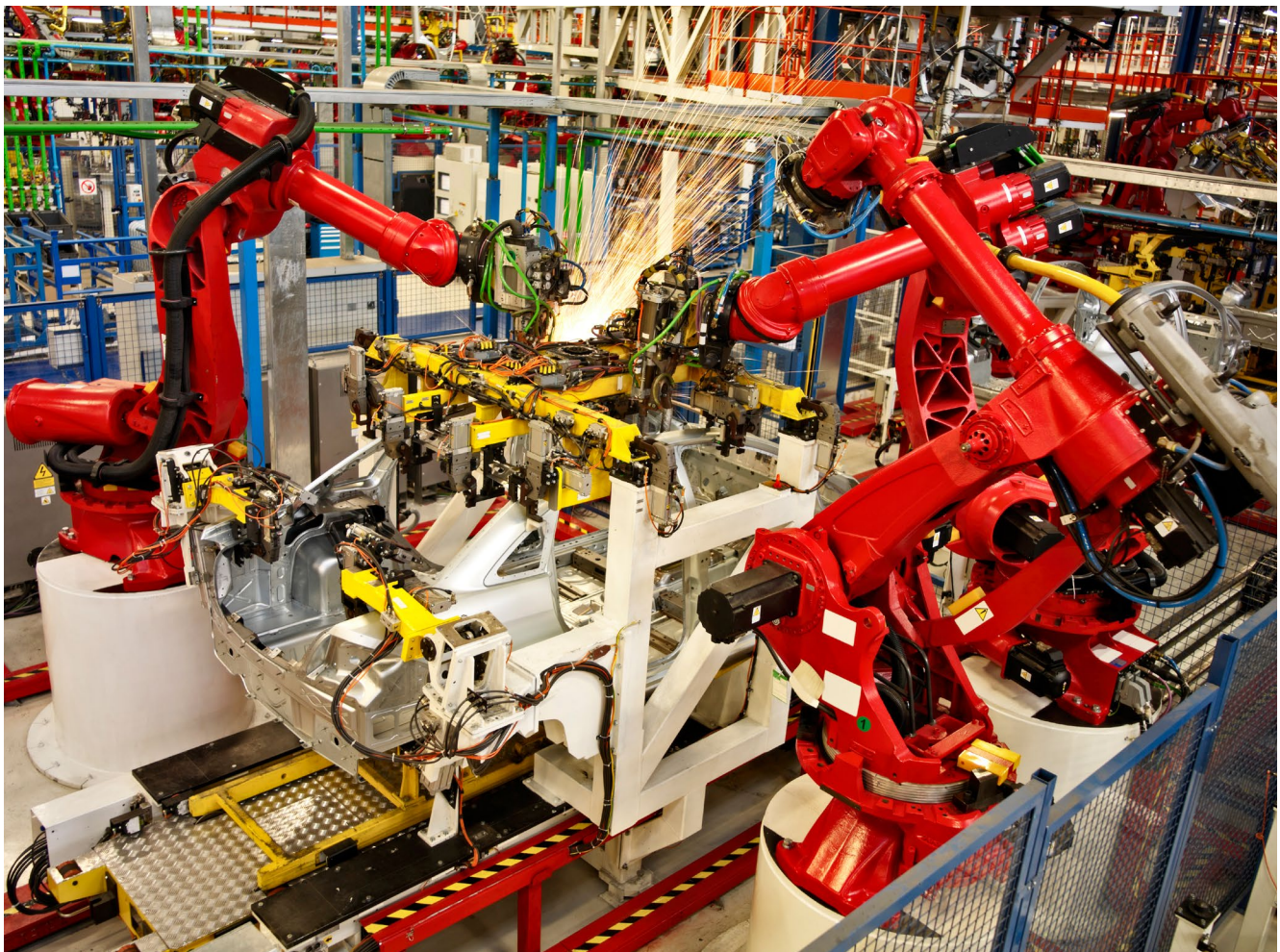

*Teflon™ is a trademark of The Chemours Company FC, LLC used under license by Danfoss Power Solutions II, LLC.*

# Everflex convoluted hose and fittings

## 8000/8500 series

Additional to Conv-O-Crimp fittings the convoluted hose is also qualified with OTC fittings but not recommended for the conveyance of air or any other kind of gases.

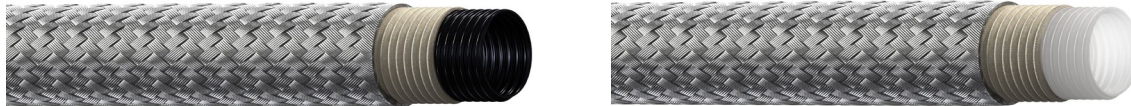

Part Number	Hose size	Hose I.D.	Nominal I.D.	Max nominal O.D.	Working pressure	Burst pressure	Min. bend radius	Hose vacuum	Hose weight	Socket part number
			mm	mm	bar	bar	mm	mbar	kg/m	
Non-conductive										
8008	-8	1/2	14.4	20.5	103	414	38	28	.23	870000-8-CZ
8012	-12	3/4	21.0	27.9	86	345	63	28	.31	870000-12-CZ
8016	-16	1	26.9	34.0	62	248	76	20	.42	870000-16-CZ
8020	-20	1-1/4	33.2	40.6	62	248	89	12	.52	870000-20-CZ
8024	-24	1-1/2	40.1	46.4	52	207	114	10	.59	870000-24-CZ
8032	-32	2	52.3	60.4	34	138	152	5	.86	870000-32-CZ
			mm	mm	bar	bar	mm	mbar	kg/m	
Conductive										
8508	-8	1/2	14.4	20.5	103	414	38	28	.23	870000-8-CZ
8512	-12	3/4	21.0	27.9	86	345	63	28	.31	870000-12-CZ
8516	-16	1	26.9	34.0	62	248	76	20	.42	870000-16-CZ
8520	-20	1-1/4	33.2	40.6	62	248	89	12	.52	870000-20-CZ
8524	-24	1-1/2	40.1	46.4	52	207	114	10	.59	870000-24-CZ
8532	-32	2	52.3	60.4	34	138	152	5	.86	870000-32-CZ

### Construction

- Convoluted Teflon™ fluoropolymer tube with 304 stainless steel wire braid reinforcement

### Temperature range

- -54 °C to + 204 °C (-65 °F to + 400 °F)

### Crimp sockets

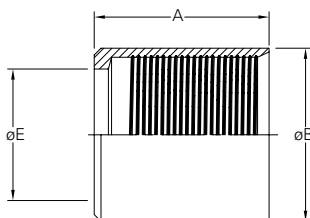

Teflon™ is a trademark of The Chemours Company FC, LLC used under license by Danfoss Power Solutions II, LLC.

### Industrial applications

- Automotive
- Platen presses
- Pharmaceutical
- Bus and truck
- Reverse osmosis
- Hydraulics
- Chemical processing
- Steam, air, water
- Tire manufacturing
- Electronics
- Steel mills
- Food processing
- Tank truck transfer

Part number	Hose size	A	øB	øE
		mm	mm	mm
870000-8-CZ	-08	28.8	24.3	17.1
870000-12-CZ	-12	32.8	32.4	24.6
870000-16-CZ	-16	35.1	38.8	30.5
870000-20-CZ	-20	35.1	45.1	36.9
870000-24-CZ	-24	35.1	51.6	43.1
870000-32-CZ	-32	41.8	66.2	57.8



WARNING: These hoses can be used to convey hazardous chemicals, steam, hot liquids, or other dangerous materials which can cause death, serious bodily injury including burns, pressure wounds, or chemical exposure if released accidentally. They should, therefore, only be handled or worked on by personnel properly trained in the safe handling of the materials or chemicals conveyed in the hoses.

# Convolut hose fittings

## Conv-O-Crimp fittings

The unique Everflex Conv-O-Crimp hose end are shipped with factory-installed Teflon™ fluoropolymer sleeves on the insert. This eliminates the time consuming, costly, and subjective step of wrapping the hose end with Teflon™ fluoropolymer tape before assembly. The result is a hose assembly system that is second to none in ease of assembly fabrication.

*Teflon™ is a trademark of The Chemours Company FC, LLC used under license by Danfoss Power Solutions II, LLC.*

Standard plating available in Chrome III and additionally in Zi-Ni on customer request. Please contact Danfoss for Zi-Ni plating.

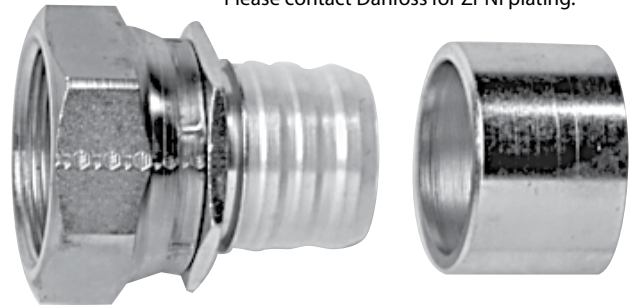

### Conv. O Crimp DKO

24° DKO metric swivel, light duty

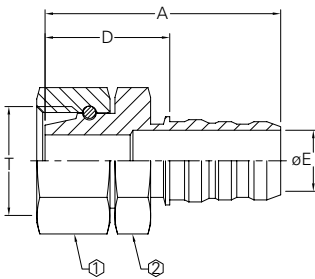

Part number	Socket number	Tube O.D.	ND	Hose size	A	D	øE	T	1	2
					mm	mm	mm	TH'D		
G820108-8-CZ	870000-8-CZ	12	12	-08	52.3	28.8	10.4	M18X1,5	22	22
G820112-12-CZ	870000-12-CZ	18	19	-12	59.5	31.5	15.4	M26X1,5	32	32
G820116-16-CZ	870000-16-CZ	22	25	-16	64.3	34.2	21.1	M30X2	36	36
G820120-20-CZ	870000-20-CZ	28	31	-20	65.3	35.1	21.1	M36X2	41	41
G820124-24-CZ	870000-24-CZ	35	38	-24	66.3	36.1	33.2	M45X2	50	50
G820132-32-CZ	870000-32-CZ	42	51	-32	76.6	39.1	44.5	M52X2	60	60

Note: Socket must be ordered seperately

### Conv. O Crimp JIC

SAE 37° swivel, crimp type

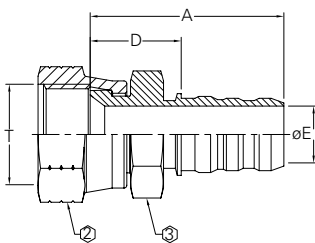

Part number	Socket number	ND	Hose size	A	D	øE	T	1	2
				mm	mm	mm	TH'D		
G820008-8-CZ	870000-8-CZ	12	-08	46	22.4	9.9	3/4"-16 UN	22	22
G820012-12-CZ	870000-12-CZ	19	-12	52.8	24.8	15.5	11/16"-12 UN	32	30
G820016-16-CZ	870000-16-CZ	25	-16	57.7	27.6	21.1	1 5/16"-12 UN	41	41
G820020-20-CZ	870000-20-CZ	31	-20	60.5	30.3	27.5	1 5/8"-12 UN	50	50
G820024-24-CZ	870000-24-CZ	38	-24	63.9	33.7	33.2	1 7/8"-12 UN	60	60
G820032-32-CZ	870000-32-CZ	51	-32	72.8	35.3	44.5	2 1/2"-12 UN	75	70

Note: Socket must be ordered seperately

### Conv. O Crimp BSP

BSP female swivel

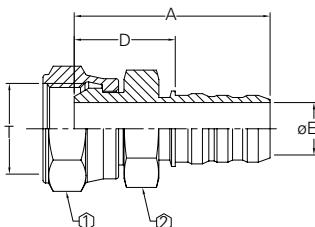

Part number	Socket number	ND	Hose size	A	D	øE	T	1	2
				mm	mm	mm	TH'D		
G820208-8-CZ	870000-8-CZ	12	-08	49.4	25.8	9.6	G 1/2"	27	22
G820212-12-CZ	870000-12-CZ	19	-12	57.8	29.8	15.5	G 3/4"	32	30
G820216-16-CZ	870000-16-CZ	25	-16	63	32.8	21.1	G 1"	41	36
G820220-20-CZ	870000-20-CZ	31	-20	64	33.8	27.5	G 1" 1/4	50	46
G820224-24-CZ	870000-24-CZ	38	-24	68.1	38	33.2	G 1" 1/2	55	50
G820232-32-CZ	870000-32-CZ	51	-32	78.5	41	44.4	G 2"	70	60

Note: Socket must be ordered seperately

ENGINEERING  
TOMORROW

*Danfoss*



# Chemical resistance chart

## Danfoss Everflex hoses made with Teflon™ fluoropolymer

Key:  
1- Excellent  
2- Good  
3- Not recommended  
0- No information - test before using

### Partial list of chemicals

This chart has been prepared as a guide only and is NOT a guarantee. The number of variables present in any particular chemical environment makes firm ratings impossible. Testing under actual service conditions is advisable in all cases to establish suitability of hose for a given purpose.

End fitting material compatibility ratings are based on a fluid temperature of 70 °C (158 °F) and higher temperatures may accelerate adverse effects. Where unusual conditions exist, or questions arise, please consult Danfoss Technical Support for assistance.

Media	Danfoss Everflex hoses made with Teflon™ fluoropolymer	Danfoss Teflon™ fluoropolymer fittings in carbon steel
Acetaldehyde	1	1
Acetic acid 10%	1	3
Acetic acid 30%	1	3
Acetic acid glacial	1	0
Acetic Anhydride	1	3
Acetone	1	1
Acetylene	1	0
Acrylonitrile	1	1
Acetyl Chloride	0	0
Alcohols	1	3
Allyl Chloride	0	0
Alum, Ammonium Or Potassium	1	3
Aluminum Acetate	1	0
Aluminum Bromide	1	3
Aluminum Chloride	1	3
Aluminum Fluoride	1	3
Aluminum Hydroxide	1	0
Aluminum Nitrite	1	3
Aluminum Oxchloride	0	0
Aluminum Salts	1	0
Aluminium Sulfate	1	3
Ammonia, Anhydrous	1	1
Ammonia, Aqueous	1	0
Ammonium Acetate	0	0
Ammonium Carbonate	0	1
Ammonium Chloride	1	0
Ammonium Fluoride	0	0
Ammonium Hydroxide	1	2
Ammonium Metaphosphate	1	1
Ammonium Nitrate	1	1
Ammonium Nitrite	0	0
Ammonium Persulfate	0	0
Ammonium Phosphate	1	3
Ammonium Sulfate	1	1
Ammonium Thiocyanate	1	1
Amyl Acetate	1	3

Media	Danfoss Everflex hoses made with Teflon™ fluoropolymer	Danfoss Teflon™ fluoropolymer fittings in carbon steel
Amy Alcohol	1	1
Amy Chloride	1	0
Amyl Chloronaphthalene	1	0
Amyl Naphthalene	1	0
Aniline	1	2
Aniline Dyes	1	3
Aniline Hydroxide	1	0
Animal Fats	1	1
Antimony Chloride	0	0
Antimony Trochloride	0	0
Aqua Regia	1	0
Arsenic Acid	1	2
Askarel	0	1
Asphalt	1	1
Barium Carbonate	1	2
Barium Chloride	1	3
Barium Hydroxide	1	2
Barium Sulfate	1	1
Barium Sulfide	1	3
Beer	1	2
Beet Sugar Liquids	1	1
Benzene	1	1
Benzenesulfonic Acid	0	3
Benzaldehyde	1	1
Benzine	1	1
Benzyl Alcohol	1	1
Benzonic Acid	0	0
Benzoyl Chloride	0	0
Benzyl Benzoate	1	1
Benzyl Chloride	1	1
Bismuth Carbonate	1	1
Black Sulphate Liquor	1	1
Blast Furnace Gas	1	1
Borax	1	2
Bordeaux Mixture	1	0
Boric Acid	1	3
Brine	1	2

# Chemical resistance chart

## Danfoss Everflex hoses made with Teflon™ fluoropolymer

Key:  
1- Excellent  
2- Good  
3- Not recommended  
0- No information - test before using

Media	Danfoss Everflex hoses made with Teflon™ fluoropolymer	Danfoss Teflon™ fluoropolymer fittings in carbon steel	Media	Danfoss Everflex hoses made with Teflon™ fluoropolymer	Danfoss Teflon™ fluoropolymer fittings in carbon steel
Bromine Gas	1	3	Chlorine, Trifluoride	0	3
Bromine Liquid	1	3	Chloroacetic, Acid	1	3
Bromine Water	1	3	Chlorobenzene	1	1
Bunker Oil	1	1	Chloribenzene Chloride	0	0
Butadiene	1	0	Chlorobromomethane	1	1
Butane	1	1	Chloroform	1	1
Butter Oil	1	1	O-Chloronaphthalene	1	1
Butyric Acid	1	3	Chlorosulfonic Acid	1	3
Butyl Acetate	1	2	Chlorotoluene	1	1
Butyl Alcohol	1	1	Chromium Trioxide	0	0
Butyl Amine	0	1	Chromic Acid	1	3
Butyl Carbitol	1	1	Citric Acid	1	3
Butyl Chloride	0	0	Cod Liver Oil	1	1
Butyl Phenol	0	0	Code Oven Gas	1	1
Butyl Stearate	1	1	Copper Chloride	1	3
Butyl Mercaptan	1	0	Copper Cyanide	1	0
Butyraldehyde	1	0	Copper Fluoride	0	0
Cadmium Cyanide	0	0	Copper Nitrate	0	0
Calcium Acetate	1	1	Copper Sulfate	1	3
Calcium Bisulfate	1	0	Corn Oil	1	1
Calcium Carbonate	1	1	Corn Syrup	1	1
Calcium Chlorate	1	0	Cottonseed Oil	1	1
Calcium Chloride	1	3	Creosote	1	2
Calcium Hydroxide	1	3	Cresol	1	2
Calcium Hypochlorite	1	0	Cresylic Acid	0	0
Calcium Nitrate	1	1	Crude Wax	1	1
Calcium Silicate	1	1	Cutting Oil	1	1
Calcium Sulfate	1	1	Cyclohexane	1	1
Calcium Sulfide	1	1	Cyclohexanone	1	0
Calcium Phosphate	0	0	Cymene	1	0
Cane Sugar Liquors	1	1	Decalin	1	0
Caprylic Acid	0	0	Denatured Alcohol	1	1
Carbonic Acid	1	3	Diacetone	1	1
Carbon Dioxide	1	1	Diacetone Alcohol	1	1
Carbon Disulfide	0	2	Dibenzyl Ether	1	1
Carbonic Acid	1	3	Dibutyl Ether	1	1
Carbon Monoxide	1	1	Dibutyl Phthalate	1	1
Carbon Tetrachloride	1	3	Dibutyl Sebacate	1	0
Castor Oil	1	1	Dichlorethylene	0	0
Caustic Soda	1	2	Dichlorobenzene	1	0
Cellosolve, Acetate	1	1	Diesel Oil	1	1
Cellosolve, Butyl	1	1	Diethylamine	1	0
Cellulube	1	1	Diethyl Ether	1	1
Cetyl Alcohol	0	0	Diethylene Glycol	1	1
Chloroacetic Acid	1	3	Diethyl Phthalate	1	0
Chloral Hydrate	0	0	Diethyl Sebacate	1	0
Chlorine, Gaseous, Dry	1	2	Di-Isobutylene	0	0
Chlorine, Gaseous, Wet	1	3	Di-Isopropyl Ketone	1	0

# Chemical resistance chart

## Danfoss Everflex hoses made with Teflon™ fluoropolymer

Key:  
1- Excellent  
2- Good  
3- Not recommended  
0- No information - test before using

Media	Danfoss Everflex hoses made with Teflon™ fluoropolymer	Danfoss Teflon™ fluoropolymer fittings in carbon steel
Dimethyl Analine	1	0
Dimethyl Formamide	0	1
Dimetyl Phthalate	1	0
Dioctyl Phthalate	1	1
Dioxane	1	1
Dipentene	1	1
Ethanolamine	1	1
Ethers	1	1
Ethyl Acetate	1	1
Ethyl Acetoacetate	1	1
Ethyl Acrylate	0	1
Ethyl Alcohol	1	1
Ethyl Benzene	1	1
Ethyl Bromide	0	0
Ethyl Cellulose	1	1
Ethyl Chloride	1	2
Ethyl Ether	1	2
Ethyl Lactate	0	0
Ethyl Mercaptan	1	2
Ethyl Pentochlorobenzene	1	2
Ethyl Silicate	1	1
Ethylene Chloride	1	2
Ethylene Chlorohydrin	1	0
Ethylene Diamine	1	0
Ethylene Dichloride	1	3
Ethylene Glycol	1	2
Ethylene Oxide	0	0
Fatty Acids	1	0
Ferric Chloride	1	3
Ferric Nitrate	1	3
Ferric Sulfate	1	3
Ferrous Chloride	1	3
Ferrous Nitrate	1	0
Ferrous Sulfate	1	3
Fluorine	0	0
Fluoroboric Acid	1	0
Formaldehyde	1	0
Formic Acid	1	3
Freon 12	2	3
Freon 114	2	3
Fuel Oil	1	2
Fumaric Acid	0	0
Furan Furfuran	1	1
Furfural	1	2
Gallic Acid	1	3
Gasoline	1	2
Glauber's Salt	0	1
Glucose	1	1

Media	Danfoss Everflex hoses made with Teflon™ fluoropolymer	Danfoss Teflon™ fluoropolymer fittings in carbon steel
Glue	1	2
Glycerin	1	2
Glycerol	1	1
Glycols	1	1
Green Sulphate Liquor	1	1
Heptane	1	1
n-Hexaldehyde	1	1
Hexane	1	1
Hexene	1	1
Hexyl Alcohol	1	1
Hydraulic Oil, Petroleum	1	1
Hydrobromic Acid 10%	1	3
Hydrobromic Acid 30%	1	3
Hydrochloric Acid 10%	1	3
Hydrochloric Acid 50%	1	3
Hydrochloric Acid Concentrate	1	3
Hydrocyanic Acid	1	3
Hydrofluoric Acid Concentrated	1	3
Hydrofluoric Acid 40%	1	3
Hydrofluoric Acid 60%	1	3
Hydrofluosilicic Acid	1	3
Hydrogen Bromide	0	0
Hydrogen Gaseous	1	1
Hydrogen Peroxide 70%	1	3
Hydrogen Sulfide Gaseous	1	3
Hydroquinone	0	0
Hydroxylamine Sulfate	0	0
Iodine	0	0
Isobutyl Alcohol	1	1
Iso Octane	1	1
Isopropyl Acetate	1	1
Isopropyl Alcohol	1	1
Isopropyl Ether	1	1
Kerosene	1	1
Ketones	0	0
Lacquers	1	3
Lacquers Solvents	1	3
Lactic Acid	1	3
Lard	1	1
Lead Acetate	1	2
Lead Nitrate	1	2
Lyme Bleach	0	3
Linoleic Acid	1	0
Linseed Oil	1	2
Lubricating Oils, Petroleum	1	1
Magnesium Chloride	1	3

Teflon™ is a trademark of The Chemours Company FC, LLC used under license by Danfoss Power Solutions II, LLC.

# Chemical resistance chart

## Danfoss Everflex hoses made with Teflon™ fluoropolymer

Key:  
1- Excellent  
2- Good  
3- Not recommended  
0- No information - test before using

Media	Danfoss Everflex hoses made with Teflon™ fluoropolymer	Danfoss Teflon™ fluoropolymer fittings in carbon steel	Media	Danfoss Everflex hoses made with Teflon™ fluoropolymer	Danfoss Teflon™ fluoropolymer fittings in carbon steel
Magnesium Hydroxide	1	1	Oleic Acid	1	2
Magnesium Nitrate	0	0	Olive Oil	1	2
Magnesium Sulfate	1	2	Oxalic Acid	1	3
Malic Acid	1	2	Oxygen Gaseous	1	1
Mercuric Chloride	1	3	Ozone	1	1
Mercury	1	1	Paint	1	0
Mesityl Oxide	1	1	Palmitic Acid	1	1
Methanol	1	0	Peanut Oil	1	1
Methyl Acetate	1	1	Perchloric Acid	1	0
Methyl Acrylate	0	1	Perchloroethylene	1	1
Methyl Alcohol	1	1	Petroleum	1	1
Methyl Bromide	1	1	Phenol	1	3
Methyl Butyl Katone	0	1	Phorone	1	1
Methyl Chloride	1	1	Phosgene	0	0
Methylene Chloride	1	1	Phosphoric Acid 20%	1	3
Methylethyl Ketone (MEK)	1	1	Phosphoric Acid 100%	1	3
Methyl Formate	1	1	Picric Acid	1	3
Methyl Isobutyl Ketone	1	1	Pinene	1	1
Methyl Methacrylate	1	1	Pine Oil	1	1
Methyl Salicylate	1	1	Plating Solutions Brass	0	0
Methyl Sulphate	0	0	Cadmium	0	0
Methyl Trichlorosilane	0	0	Chrome	1	0
Milk	1	3	Potassium Acetate	1	0
Mineral Oil	1	1	Potassium Chloride	1	2
Molasses	0	0	Potassium Cyanide	1	2
Monochlorobenzene	1	1	Potassium Dichromate	1	0
Monoethanolamine	0	1	Potassium Hydroxide 30%	1	3
Naptha	1	2	Potassium Hydroxide 100%	1	3
Napthalene	1	0	Potassium Nitrate	1	3
Naphthenic Acid	1	0	Potassium Sulfate	1	2
Natural Gas	1	1	Propane	1	1
Nickel Acetate	1	1	Propyl Acetate	0	1
Nickel Chloride	1	3	Propyl Alcohol	1	1
Nickel Nitrate	0	0	Pyridine 50%	1	0
Nickel Sulfate	1	0	Red Oil	1	2
Niter Cake	0	3	Salicylic Acid	0	0
Nitric Acid 5%	1	3	Salt Water	1	2
Nitric Acid 10%	1	3	Sewage	1	3
Nitric Acid 30%	1	3	Silicone Greases	0	1
Nitric Acid above 30%	1	3	Silicone Oils	0	1
Nitric Acid, Red Fuming	1	3	Silver Cyanide	0	0
Nitrobenzene	1	1	Silver Nitrate	1	2
Nitroethane	1	0	Skydrol 500 and 7000	1	1
Nitrogen, Gaseous	1	1	Soap Solutions	1	1
Nitrogen Tetroxide	0	0	Soda Ash	0	1
Nitrous Acid	0	0	Sodium Acetate	1	1
Nitrous Oxide	0	0	Sodium Benzoate	1	2
n-Octane	0	1	Sodium Bicarbonate	1	2
Octyl Alcohol	1	1	Sodium Bisulfate	1	1
Oil, SAE	1	1	Sodium Borate	1	1



# Chemical resistance chart

## Danfoss Everflex hoses made with Teflon™ fluoropolymer

Key:  
1- Excellent  
2- Good  
3- Not recommended  
0- No information - test before using

Media	Danfoss Everflex hoses made with Teflon™ fluoropolymer	Danfoss Teflon™ fluoropolymer fittings in carbon steel	Media	Danfoss Everflex hoses made with Teflon™ fluoropolymer	Danfoss Teflon™ fluoropolymer fittings in carbon steel
Sodium Chloride	1	2	Trichloroacetic Acid 10%	0	0
Sodium Cyanide	1	2	Trichloroacetic Acid 100%	0	0
Sodium Chlorate	0	0	Trichlorethylene	1	3
Sodium Hydroxide 30%	1	2	Trichloroethylene	1	3
Sodium Hydroxide 40%	1	2	Trichlorophenol	0	0
Sodium Hydroxide 100%	1	2	Tricresyl Phosphate	1	1
Sodium Chlorite	0	0	Tung Oil	1	1
Sodium Metaphosphate	1	3	Turpentine	1	0
Sodium Nitrate	1	1	Urea Solution 50%	1	1
Sodium Perborate	1	3	Urine	1	0
Sodium Peroxide	1	3	Varnish	0	2
Sodium Phosphate	1	0	Vegetable Oils	1	1
Sodium Thiosulfate	1	3	Versilube	1	1
Soybean Oil	1	1	Vinegar	1	3
Stannic Chloride	1	3	Vinyl Acetate	0	0
Starch	0	0	Vinyl Chloride	1	2
Steam	1	1	Water	1	2
Stearic Acid	1	3	Whiskey, Wines	1	3
Stoddard Solvent	1	2	Xylene	1	3
Styrene	1	2	Zinc Acetate	1	1
Sucrose Solution	1	1	Zinc Chloride	1	3
Sulfur 200°F	1	2	Zinc Sulfate	1	3
Sulfur Chloride	1	3			
Sulfur Dioxide	1	2			
Sulfur Dioxide Liquid	1	0			
Sulfur Dioxide Wet Gas	1	0			
Sulfur Monochloride	0	0			
Sulfur Trioxide	1	2			
Sulfur Trioxide Liquid	0	0			
Sulfur Trioxide Wet Gas	0	0			
Sulfuric Acid 10%	1	3			
96%	1	3			
98%	1	2			
100%	1	0			
Fuming	1	2			
Sulfurous Acid 10%	1	3			
Sulfurous Acid 75%	1	3			
Tallow	0	0			
Tannic Acid 10%	1	2			
Tar, Bituminous	1	1			
Tartaric Acid	1	0			
Tetrachloroethylene	0	0			
Terpineol	1	0			
Titanium Tetrachloride	0	1			
Toluene	1	1			
Toluene Diisocyanate	0	0			
Transformer Oil	1	1			
Transmission Fluid Type A	1	1			
Tributoxyethyl Phosphate	1	1			
Tributyl Phosphate	1	1			

Teflon™ is a trademark of The Chemours Company FC, LLC used under license by Danfoss Power Solutions II, LLC.

ENGINEERING  
TOMORROW



**Danfoss Power Solutions**, Nordborgvej 81, 6430 Nordborg, Denmark, Tel. +45 74 88 22 22, Fax +45 74 65 25 80  
www.danfoss.com, E-mail: info@danfoss.com

Any information, including, but not limited to information on selection of product, its application or use, product design, weight, dimensions, capacity or any other technical data in product manuals, catalogues descriptions, advertisements, etc. and whether made available in writing, orally, electronically, online or via download, shall be considered informative, and is only binding if and to the extent, explicit reference is made in a quotation or order confirmation. Danfoss cannot accept any responsibility for possible errors in catalogues, brochures, videos and other material. Danfoss reserves the right to alter its products without notice. This also applies to products ordered but not delivered provided that such alterations can be made without changes to form, fit or function of the product. All trademarks in this material are property of Danfoss A/S or Danfoss group companies. Danfoss and the Danfoss logo are trademarks of Danfoss A/S. All rights reserved.