

Push-to-Connect Couplings

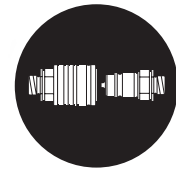

Multi Couplings



Screw-to-Connect Couplings

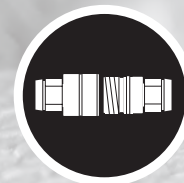

Germany

Walter Stauffenberg GmbH & Co. KG

Im Ehrenfeld 4
58791 Werdohl

www.stauff.com

STAUFF products and services are globally available through wholly-owned subsidiaries and a tight network of authorised distributors and representatives in all major industrial regions of the world.

You can find detailed contact information on the last two pages of this product catalogue or at www.stauff.com/contact.

Please note: Unless otherwise stated, all data and figures in this product catalogue are approximate values and are only valid as references, which are not binding (also in respect to any third parties' rights of protection) and thus do not release the customer / user from checking and testing the suitability of the products for the foreseen purposes. Therefore, data and figures can only be used in a limited sense for construction purposes.

The application of the products is beyond the control possibilities of the manufacturer and, therefore, is exclusively subject to the responsibility of the customer / user.

In the event that a liability is nevertheless considered, any compensation will be limited to the value of the goods supplied by the manufacturer and used by the customer / user. As a matter of course, the manufacturer guarantees the perfect quality of all products in accordance with the General Terms and Conditions of Business and Sale.

Subject to modifications due to the ongoing development and improvement of the products.

With the publication of this product catalogue, previous editions are no longer valid.

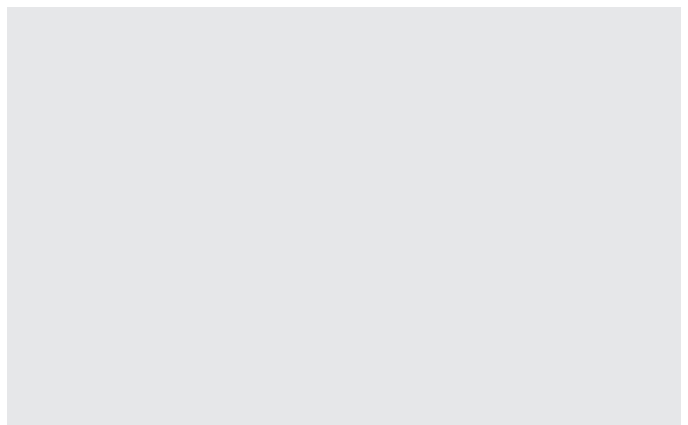
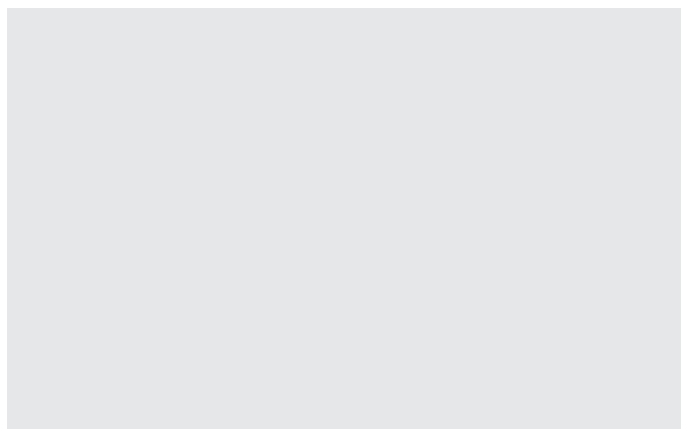

Introduction		4 - 11	
Overview (Product Overview / Structure of the Part Numbers)		12 - 15	
Push-to-Connect Couplings	FF Series ▪ Flat Face Coupling acc. to ISO 16028	17 - 28	FF
	FC Series ▪ Flat Face Coupling acc. to ISO 16028, Connect Under Pressure	29 - 36	FC
	FH Series ▪ Flat Face Coupling acc. to ISO 16028, Stainless Steel	37 - 40	FH
	FO Series ▪ Flat Face Coupling, Stainless Steel	41 - 44	FO
	HP Series ▪ ISO 7241-1, Series A, Push-Pull	45 - 56	HP/HU
	HU Series ▪ ISO 7241-1, Series A, Push-Pull, Connect Under Pressure	53	
	UX Series ▪ ISO 7241-1, Series A, Push-Pull, Connect Under Pressure	57 - 60	UX
	IA Series ▪ ISO 7241-1, Series A	61 - 66	IA
	IA Series ▪ ISO 7241-1, Series A, Stainless Steel	67 - 72	
	IB Series ▪ ISO 7241-1, Series B	73 - 78	IB
	IB Series ▪ ISO 7241-1, Series B, Brass	79 - 84	
	IB Series ▪ ISO 7241-1, Series B, Stainless Steel	85 - 90	
	ID Series	91 - 94	ID
	BP Series ▪ ISO 5676	95 - 98	BP
	HC Series ▪ Flat Face Coupling	99 - 102	HC
	HD Series ▪ Flat Face Coupling	103 - 106	HD
HUS Series ▪ Nordic Interchange Design	107 - 109	HUS	
Multi Couplings	MK Series ▪ Multicoupling System, Flat Face Coupling	111 - 115	MK
Screw-to-Connect Couplings	HS Series ▪ ISO 14541	117 - 128	HS
	HS Series ▪ ISO 14541, Stainless Steel	129 - 134	
	PS Series ▪ For Hammer Application	135 - 138	PS
	RH Series ▪ Flat Face Coupling, Pipeline Coupling	139 - 144	RH
	FG Series ▪ Flat Face Coupling, Connect Under Pressure	145 - 150	FG
	HR Series	151 - 156	HR
	HH Series	157 - 162	HH
	HH Series ▪ Stainless Steel	163 - 168	
	HI (HIB) Series ▪ ISO 14540	169 - 172	HI
	HT Series ▪ Wing Style	173 - 176	HT
	HM Series ▪ Wing Style	177 - 180	HM
	HV Series ▪ Wing Style	181 - 185	HV
Special Applications		187 - 189	
Colour Marking Rings / Spare Parts / Accessories		191 - 221	
Technical Appendix		225 - 226	
Appendix (Product-Specific Abbreviations / Global Contact Directory)		229 - 235	





Catalogue 1 STAUFF Clamps

- Block Clamps
- Special Clamps
- Light Series Clamps
- Saddle Clamps
- U-Bolt Clamps
- Metal Clamps
- Construction Series



Catalogue 2 STAUFF Connect

- Tube Connectors
- Assembly Tools and Devices



Catalogue 3 STAUFF Flanges

- SAE Flanges
- Gear Pump Flanges



Catalogue 4 STAUFF Hose Connectors

- Hose Connectors
- High-Pressure Hose Connectors



Catalogue 5 STAUFF Quick Release Couplings

- Push-to-Connect Couplings
- Multi Couplings
- Screw-to-Connect Couplings



Catalogue 6 STAUFF Valves

- Two-Way Ball Valves
- Multi-Way Ball Valves
- Flow Control and Check Valves
- Gauge Isolator Valves





Catalogue 7 STAUFF Test

- Test Couplings
- Test Adaptors
- Test Hoses and Connectors



Catalogue 8 STAUFF Diagtronics

- Pressure Gauges
- Hydraulic Testers
- Oil Analysis Equipment



Catalogue 9 STAUFF Filtration Technology

- Replacement Filter Elements
- Pressure Filters
- Return-Line Filters
- In-Line Filters
- Spin-On Filters
- Offline and Bypass Filters
- Filtration Systems

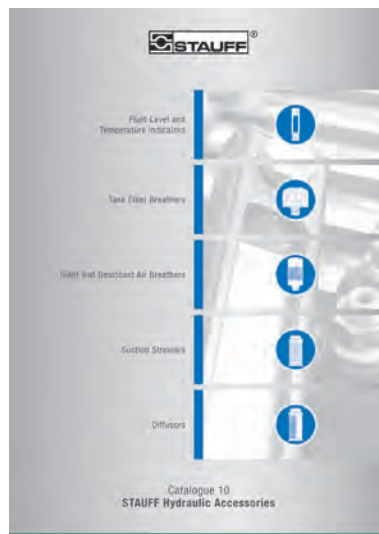

Catalogue 10 STAUFF Hydraulic Accessories

- Fluid Level and Temperature Indicators
- Tank Filler Breathers
- Giant and Desiccant Air Breathers
- Suction Strainers
- Diffusers



For more than 50 years, the companies of STAUFF Group have been developing, manufacturing and distributing pipework equipment and hydraulic components for mechanical and plant engineering and for service and industrial maintenance.

In addition to mobile and industrial hydraulic machinery, typical applications also include commercial and special purpose vehicles, rail transportation and energy technology. Likewise, STAUFF products are used in marine, oil and gas applications and in the process, food and chemical industries.

The overall range currently includes about 50000 standard products as well as numerous special and system solutions according to customer's specifications or based on our in-house development.

All STAUFF products undergo relevant testing in accordance with international regulations and are governed by the high standards of the in-house quality management system. Furthermore, many items have received certifications and approvals from various international institutes, organisations and authorities who have independently confirmed the quality and performance of the products.

Wholly-owned manufacturing, sales and service facilities in 18 countries and a tight global network of authorised distribution partners ensure high presence and service paired with a maximum of availability.



Quality Management – ISO 9001:2015
Environmental Management – ISO 14001:2015
Safety Management – ISO 45001:2018
Energy Management – ISO 50001:2018

STAUFF LINE Components

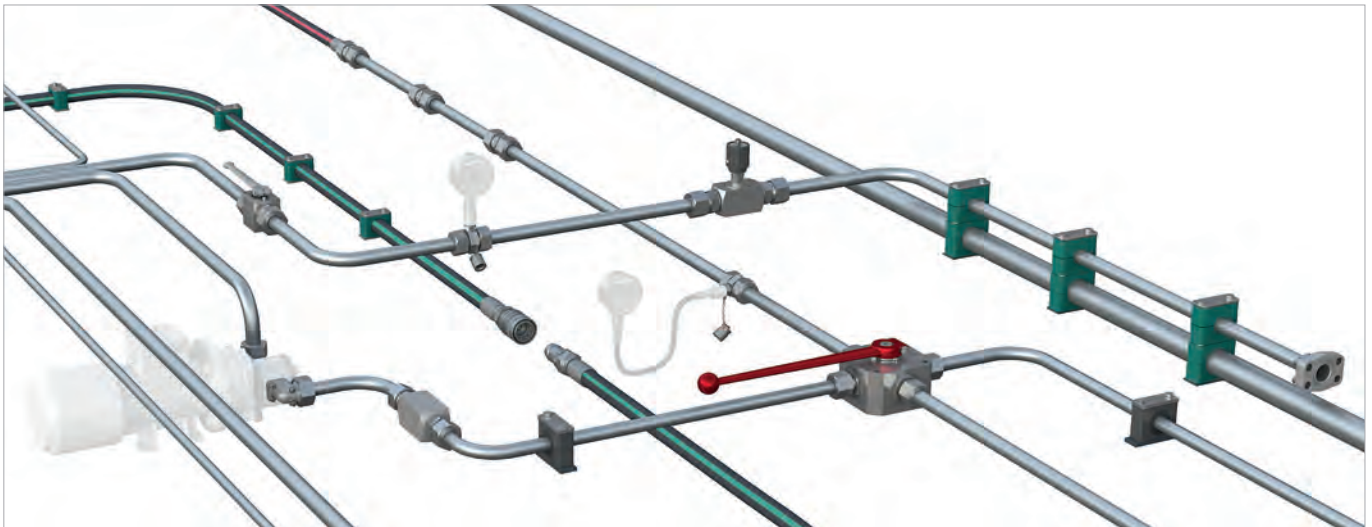

With the seven dedicated **STAUFF Line** product groups

- **STAUFF Clamps**
- **STAUFF Connect**
- **STAUFF Flanges**
- **STAUFF Hose Connectors**
- **STAUFF Quick Release Couplings**
- **STAUFF Valves**
- **STAUFF Test**

from own, in-house development and manufacturing, the companies of the STAUFF Group provide a comprehensive range of components for fastening and connecting pipes, tubes and hoses for mobile and industrial hydraulic applications and many other industries.

The portfolio is completed by components for shutting-off, regulating, throttling and measuring fluid media.

In order to perfectly match each other, STAUFF Line products are designed and offered on a high, uniform level of quality. A large proportion of the range made from steel comes as standard with the premium STAUFF Zinc/Nickel surface coating, which is also optionally available for many of the other components.

This coating offers the most reliable surface protection far beyond the previous market standards – even after transport, handling and assembly of the components – and meets all current legal requirements.

If desired, Original Equipment Manufacturers can be supported with value-added services, from **technical consultation to pre-assembly, assembly and kitting** as well as **logistics services**:

- Support with the **selection of suitable standard components** and ordering options; provision of **customised solutions** according to customer's specifications or based on our in-house development – from prototyping to large scale production
- **Analysis and optimization** of existing and design and developments of new systems aimed at increasing the efficiency and performance of machines and equipment and creating value for customers by reducing the total cost
- **Pre-assembly, assembly and kitting** of individual components to customer-specific system modules
- Individually coordinated **procurement solutions** (e.g. web shop and electronic data interchange) and **supply models** (e.g. from warehousing of customised components to Kanban logistics and just-in-time delivery of pre-fabricated system modules to the assembly lines of the customers) aimed at optimising material flows



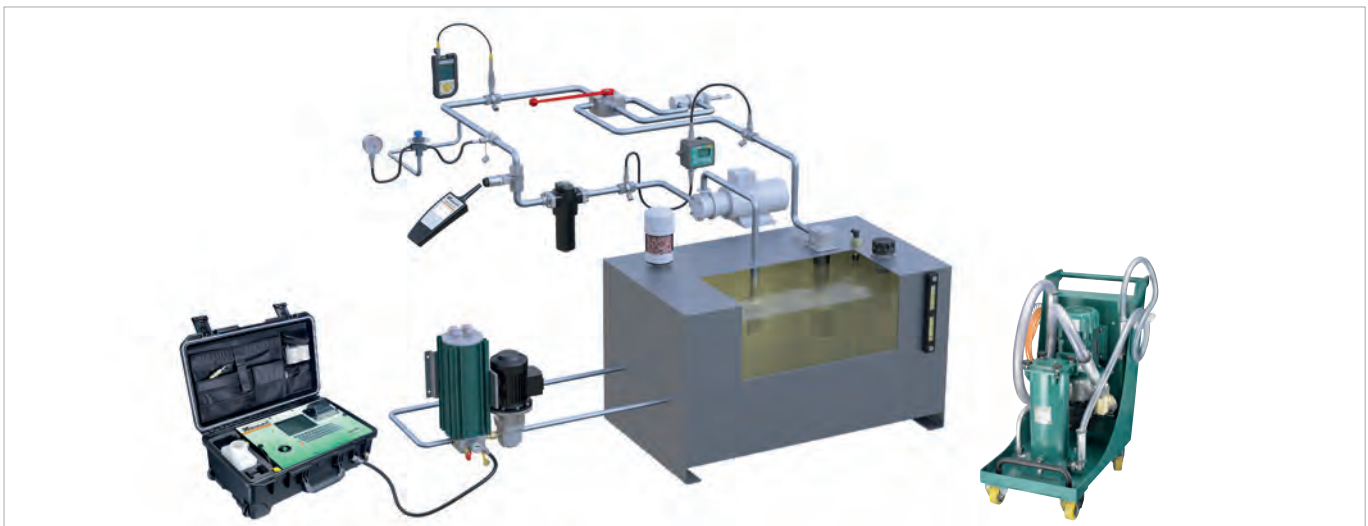

Aligned with the needs of the market, the product groups

- **STAUFF Test**
- **STAUFF Diagtronics**
- **STAUFF Filtration Technology**
- **STAUFF Hydraulic Accessories**

include a comprehensive range of analogue and digital measuring equipment and devices, filtration systems and replacement filter elements as well as accessories for the construction of tanks, reservoirs, power packs and gear boxes in mobile and industrial hydraulics.

The offer is completed by relevant value-added services:

- Support with the **selection of suitable components** and ordering options; provision of **customised solutions** according to customer's specifications or based on our in-house development – from prototyping to large scale production
- Analysis of existing hydraulic circuits aimed at filtration systems, tank components and monitoring devices that perfectly match to the specific requirements, and developing integrated concepts to increase the efficiency and performance of machines and equipment
- Individually coordinated **procurement solutions** and **supply models**





STAUFF Quick Release Couplings

STAUFF couplings have proven their value for many years in practical use in hydraulic systems. The excellent quality of the couplings is the result of continual product improvement in which the experiences of users have been taken into consideration, as well. Our high production standards, combined with our quality management system certified in accordance with EN ISO 9001, assures the quality of our products.

For the technical specifications of the individual couplings please refer to the following pages of the catalog.

Housing material

Steel according to EN 10277:
Couplings Series FF, FC, HP-10, IA, IB, ID, BP, HUS, PS, RK/RH, FG, HH, HI, HT and MK with Zinc-Nickel coating,

Zinc-Plating and Thick-Film-Passivation
(Chrome III)

Seals

NBR (Buna-N®), PTFE
ISO 3601

Operating temperature

-25 °C ... +100 °C / -13° F ... +212° F
with NBR (Buna-N®), PTFE
-25 °C ... +200 °C / -13° F ... +392° F
with FKM (Viton®)

Please contact STAUFF to require other combinations of materials.

The operating pressures specified in our catalog relate to the strength of the housing components. Standardized connector shapes may have other rated pressures, which cannot automatically be applied to the particular coupling type.

Any remodeling and modification of the couplings are prohibited. By any maintenance of our couplings it's necessary to use original STAUFF parts. In case of using of no original parts or disassembling of the couplings the warranty will be expire.

The STAUFF hydraulic couplings don't have the 94/7/EG guidance for the using in explosive field. The couplings don't have an own ignition source which could be a reason of inflame.





- Free of hexavalent chrome Cr(VI)
- ELV compliant according to 2000/53/EC (End of Life Vehicles Directive)
- REACH compliant according to 1907/2006/EC (Registration, Evaluation, Authorisation and Restriction of Chemicals)
- RoHS compliant according to 2002/95/EC (Restrictions of the Use of Hazardous Substances)



Normative references

- EN ISO 8330:2000, ISO 5675, ISO 5676, ISO 7241, ISO 16028, AMD 1





www.stauff.com/catalogues

The STAUFF online catalogue centre at www.stauff.com/catalogues provides fast and direct access to digital versions of this as well as other STAUFF product catalogues in all available languages.

Online Page-Flip Catalogues

- Easy navigation through index or the powerful full text search functionality
- Contents can be shared and forwarded by e-mail, printed or downloaded and saved in PDF file format
- Also suitable for mobile devices

Download Catalogues

- Download entire product catalogues and save them in PDF file format

The fastest way to the online page-flip catalogue:

The links that can be found at the bottom edge of all pages of this product catalogue will lead you directly to the corresponding page in the online page-flip catalogue.

In doing so, contents can be searched, shared and forwarded by e-mail, printed or downloaded and saved in PDF file format.

Scan the QR code next to the direct link with the camera of your mobile device* and also use the functions in this way.

* may require a suitable app





www.stauff.com

With the STAUFF Digital Platform available at www.stauff.com, commercial customers and users of STAUFF products can not only inform themselves in all detail about the 50000 components typically available from stock, but also directly purchase these online without complex registration.

General information about the companies of STAUFF Group, latest business and product news as well as complete global contact details also be available.

Main Functionalities of the STAUFF Digital Platform:

- Around the clock**
Check stock availability and pricing for STAUFF products in real time
- Cross references**
Search by article designations of other manufacturers / suppliers
- Live chat**
Get directly in touch with the STAUFF customer service and sales team
- CAD database**
Download 3D models and 2D drawings for STAUFF products

Advantages as a Registered User of the STAUFF Digital Platform:

- Purchase STAUFF products**
Taking customer-specific pricing and delivery conditions into account
- Ordering w/o searching**
Quick ordering by entering article number, quantity and requested delivery date
- File upload**
Direct upload of orders with multiple positions in CSV or Excel file format
- Notepad function**
Create project lists to save interesting products for later

www.stauff.com/cad

Immediate access to and free download of 3D models and 2D drawings for a growing number of STAUFF products

www.filterinterchange.com

Online database for the quick and easy identification and interchange of almost all common brands and types of replacement filter elements

Follow STAUFF and keep yourself updated:

LinkedIn
www.linkedin.com/company/stauff

Youtube
www.youtube.com/stauffgroup

STAUFF Newsletters
Automatic e-mail notifications about latest news from STAUFF
www.stauff.com/newsletter



Quick Release Couplings - Overview

Working Pressure bar / PSI	Working Pressure Range											
	1250 / 18130	1000 / 14504	900 / 13054	800 / 11603	700 / 10153	600 / 8702	500 / 7252	400 / 5802	300 / 4351	200 / 2901	100 / 1450	
Series	FF	FC	FH	FO	HP	HU	UX	IA	IA	IB	IB	
Material												
Surface Finishing												
Standard Seal Material(s) ¹												
Working Temperature												
Valve Design												
Connection												
Disconnection												
Connect Under Pressure ⁶												
Application												
ISO Interchange	ISO 16028	ISO 16028	ISO 16028		ISO 7241-1, Series A				ISO 7241-1, Series B			
Page	17	29	37	41	45	53	57	61	67	73	79	

¹ Alternative seal materials are available on request.
 Working Pressure depends on the nominal size.
 Minimum Working Pressure

² When mounting the Sleeve in Bulkhead
³ Up to max. 250 bar / 3626 PSI
⁴ Up to 33% of the Working Pressure with Tools
⁵ Max. 100 bar / 1450 PSI

⁶ Only Residual Pressure
⁷ Female Body up to max. 2,5 bar / 36 PSI,
 ISO-A Male Tip up to the max. Working Pressure allowed
⁸ Max. 20 bar / 290 PSI Residual Pressure with Tools
⁹ Up to max. 50 bar / 725 PSI with Tools



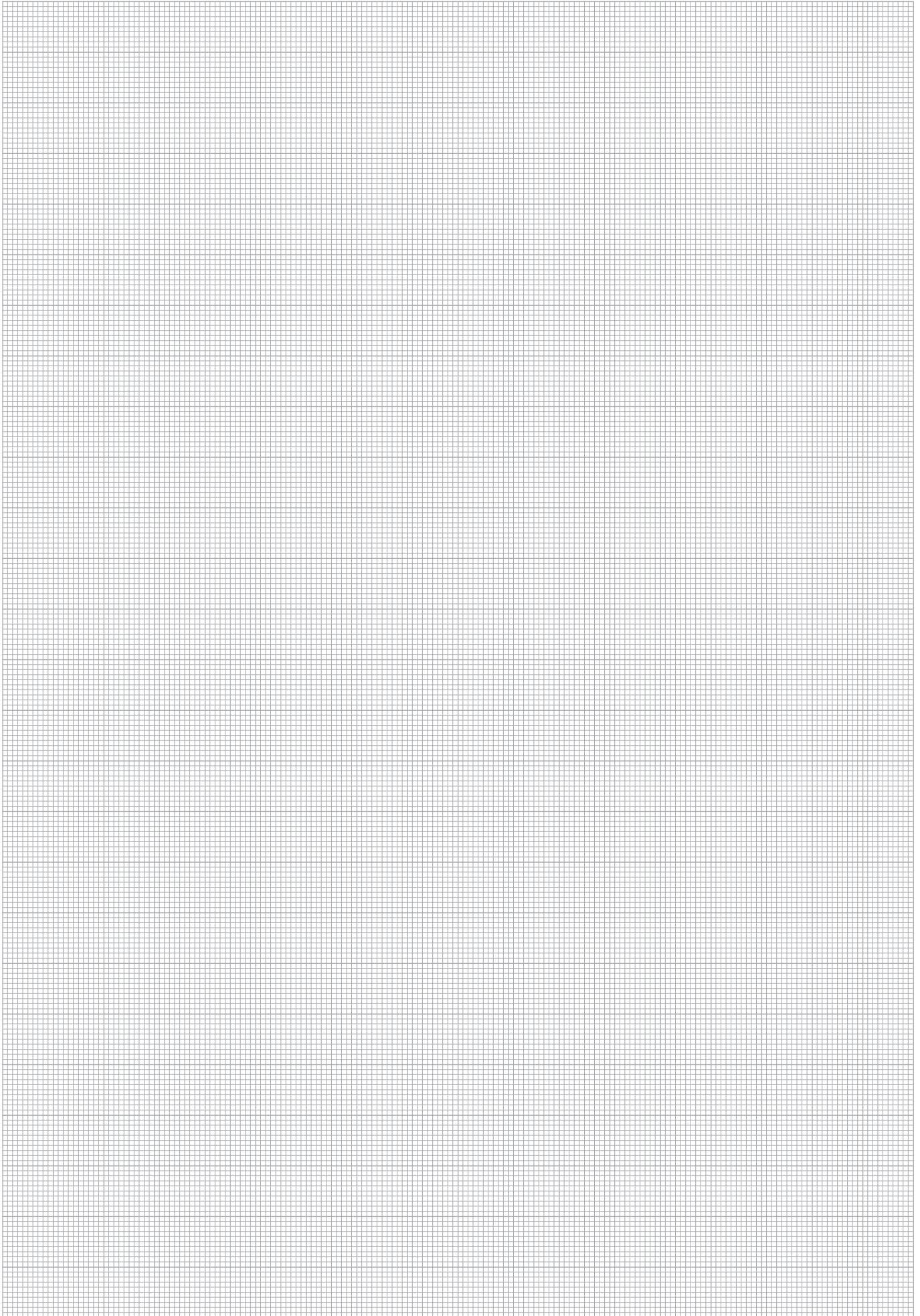

Structure of the Ordering Codes

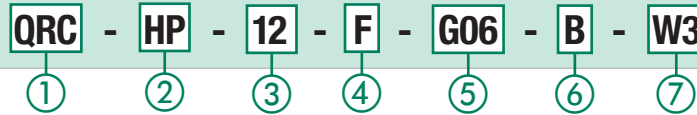

① Quick Release Coupling (QRC)

② Coupling Series				
Push-to-Connect Couplings	FF	Flat Face Coupling acc. to ISO 16028	Push-to-Connect Couplings	HUS
	FC	Flat Face Coupling acc. to ISO 16028, Connect Under Pressure	Multi Couplings	MK
	FH	Flat Face Coupling acc. to ISO 16028, Stainless Steel		HS
	FO	Flat Face Coupling, Stainless Steel		HS
	HP	ISO 7241-1, Series A, Push-Pull		PS
	UX	ISO 7241-1, Series A, Push-Pull, Connect Under Pressure		RH
	IA	ISO 7241-1, Series A		FG
	IA	ISO 7241-1, Series A, Stainless Steel	Screw-to-Connect Couplings	HR
	IB	ISO 7241-1, Series B		HH
	IB	ISO 7241-1, Series B, Brass		HH
	IB	ISO 7241-1, Series B, Stainless Steel		HI
	ID	Push-to-Connect Coupling		HT
	BP	ISO 5676		HM
	HC	Flat Face Coupling		HV
	HD	Flat Face Coupling		

③ Coupling Size																		
STAUFF	ISO 4397	Size	Flange		Metric Ports						Imperial Ports							
			ISO 6162-1	ISO 6261-2	DIN EN ISO 8434-1		EN ISO 6149		EN ISO 9974		ISO 1179 BSP		SAE J514	SAE J1453	SAE J1926-1	ANSI B 1.20.1		
Nominal Size	DN	Inch	350 bar (3000 PSI)	420 bar (6000 PSI)	Light Series	Heavy Series	Light Series	Heavy Series	Light Series	Heavy Series	Light Series	Heavy Series	Light Series	Heavy Series	UN / UNF	UN / UNF	UN / UNF	NPT / NPTF
03	3,2	1/8					M8x1	M10x1										
04	4				M12x1,5-6	M14x1,5-6	M10x1	M12x1,5	M10x1	M12x1,5			G 1/8					1/8-27
05	5	3/16				M16x1,5-8	M18x1,5-10	M12x5	M14x1,5	M14x1,5	M16x1,5							
06	6,3	1/4				M16x1,5-10	M20x1,5-12	M16x1,5	M18x1,5	M18x1,5	M20x1,5			G 1/4				
08	8	5/16				M18x1,5-12	M22x1,5-14	M18x1,8	M18x1,5	M18x1,5	M20x1,5			G 3/8				
10	10	3/8				M22x1,5-15	M24x1,5-16	M22x1,5	M22x1,5	M22x1,5	M22x1,5			G 1/2				
12	12,5	1/2	13 (1/2")	13 (1/2")	M26x1,5-18	M30x2-20	M27x2	M30x2		M27x2				G 3/4				
16	16	5/8				M30x2-20	M36x2-25	M30x2	M33x2	M26x1,5	M33x2			G 3/4				
19	19	3/4	19 (3/4")	19 (3/4")		M36x2-25	M42x2-30	M33x2	M42x2	M33x2	M42x2			G 1				
25	25	1	25 (1")	25 (1")		M45x2-35	M52x2-38	M42x2	M48x2	M42x2	M48x2			G 1 1/4				
31	31,5	1 1/4	32 (1 1/4")	32 (1 1/4")										G 1 1/2				
38	38	1 1/2	38 (1 1/2")	38 (1 1/2")										G 2				
51	51	2	51 (2")	51 (2")														
63	63	2 1/2	64 (2 1/2")	64 (2 1/2")														

④ Component of Coupling				⑤ Type of Connection			
CC	Complete Coupling	BF	Dust Cover Body with flip-lid	Gxx	BSP Female thread ISO 1179	F6xx	Flange head 420 bar (6000 PSI), ISO 6262-2
F	Female Body with Valve	HM	Male Tip holder (parking station for Male Tip)	Bxx	BSP Male thread ISO 1179	F3xx	Flange head 350 bar (3000 PSI), ISO 6162-1
FD	Female Body with Dust Plug / Cap	BH	Breakaway holder	NFxx	NPTF Female thread ANSI B 1.20.3	UxxM	UNF Male ORB thread SAE J1926-1, ISO 11926
FF	Female Body with fixed Dust Cover flap lid	FSK	Female Body Sealing Kit	Uxx	UNF Female thread SAE J1926-1, ISO 11926	C6XX	Counter Flange Plate 420 bar (6000 PSI), ISO 6162-2
M	Male Tip with Valve	MSK	Male Tip Sealing Kit	MxxM	Metric Male thread ISO 6149	F6xxM/U/H	
MW	Male Tip without Valve	FP	Fixed part	Mxx	Metric Female thread ISO 6149		Flange 420 bar (6000 PSI), with metric thread / UNC tread / Through hole
MD	Male Tip with Dust Cap / Plug	MP	Mobile part	xxL	Metric Male thread with 24° cone Light Series ISO 8434-1		
DF	Dust Cap/ Plug for Female Body	LV	Lock Valve	LB	Metric Male thread with 24° cone Light Series, ISO 8434-1, Bulkhead	C6xxM/U/H	
DM	Dust Cap/ Plug for Male Tip	SP	Spare parts	xxS	Metric Male thread with 24° cone Heavy Series ISO 8434-1		Counter Flange 420 bar (6000 PSI), with metric thread / UNC tread / Through hole
SF	Slip-on flip lid	FW	Female Body without Valve	SB	Metric Male thread with 24° cone Heavy Series, ISO 8434-1, Bulkhead		
FDS	Female Body with Parking Station						

⑥ Sealing Material			
B	NBR (Buna-N®)	BV	NBR (Buna-N®) + FKM (Viton®)
PT	PTFE (Teflon)	VP	FKM (Viton®) + PU (Polyurethan)
V	FKM (Viton®)	S1	NBR (Buna-N®) + PU (Polyurethan) + PTFE (Teflon)
E	EPDM (Ethylen-Propylen Dien-Kautschuk)	S2	NBR (Buna-N®) + PU (Polyurethan) + PTFE (Teflon) + FKM (Viton®)
PU	Polyurethan	HB	High emperature NBR
BT	NBR (Buna-N®) + PTFE (Teflon)	HV	High temperature NBR + FKM (Viton®)
VT	FKM (Viton®) + PTFE (Teflon)	S3	High temperature NBR + FKM (Viton®) + PTFE (Teflon)
BP	NBR (Buna-N®) + PU (Polyurethan)	S4	NBR (Buna-N®) + FKM (Viton®) + PTFE (Teflon)
		S5	NBR (Buna-N®) + PU (Polyurethan) + POM (Polyoxymethylen)

⑦ Surface / Material	
W3	Steel, zinc-nickel plated
W4	Stainless Steel V2A
W5	Stainless Steel V4A
W48	Steel, zinc plated (with Chrome VI, A3C)
W66	Steel chromium VI-free zinc plated plus thick-layer-passivation (contents CrIII)
W69	Brass
W89	Aluminium exotaxated
W126	Aluminium exotaxated and Stainless Steel V2A
W138	Steel, zinc-nickel plated and zinc (with Chrome VI) plated
W139	Brass and Plastic
W162	Brass and Steel chromium VI-free zinc plated plus thick-layer-passivation (contents CrIII)
K	Plastic





Product Description

Flat Face Push-to-Connect Couplings of the FF Series from STAUFF consist of a male tip and a female body and are used for quick and easy connection (push) and disconnection of tubes, pipes and hoses by hand, i.e. without tools.

The Series was developed in the following nominal sizes 06, 10, 12, 16, 19, 25, 38 (1/4" - 1 1/2") and can be connected under pressure with male tips of the FC series.

A maximum operating pressure of 350 bar (5076 PSI) can also be achieved in combination with male tips of the STAUFF FC Series (size 10, 12, 16, 19).

The proven design is suitable for use in agricultural and forestry machinery, construction machinery and hydraulic attachments.

Features

- Flat Face
- Coupling made from carbon steel with Zinc/Nickel surface coating
- ISO Interchange acc. to ISO 16028
- Maximum working pressure up to 400 bar (5802 PSI)
- Can be connected by hand while having a residual pressure up to 250 bar (3626 PSI) on the male side in combination with Male Tips of the QRC-FC Series
- Powerful flow characteristics with minimal pressure drop
- Heavy internal components
- Integrated locking system preventing unintentional release of the coupling
- Wide knurled bands on female body for easy gripping

Applications

	Agricultural and Forestry Machinery		Construction Machinery		Industrial Hydraulic
---	--	---	-------------------------------	---	-----------------------------

Top Features

	Zinc/Nickel coating		Designed for secure connection
---	----------------------------	---	---------------------------------------



Series FF - Carbon Steel

FF

Material	Carbon Steel
Surface Finishing	Zinc-Nickel, Zinc-Plating and Thick-Film-Passivation (Chrome III) only FH/FU 51
Standard Seal Material(s)	NBR (Buna-N®), PTFE, PU ²
Working Temperature	-25° C ... +100° C / -13° F ... +212° F
Valve Design	Flat Face
Connection	Push
Disconnection	Actuate Push Sleeve
Connect Under Pressure	not allowed, (Male Tip Series FU up to the max. Working Pressure allowed)
Application	Construction Machinery, Industrial Hydraulic
ISO Interchange	ISO 16028



² Alternative seal materials are available on request.

Technical Data

Series	BG	DN Zoll	DN metric ISO 4397	Q _{max}		Working Pressure*		Bursting Pressure Connected		Female Body		Male Tip		Spillage	
				l/min	US GPM	bar	PSI	bar	PSI	bar	PSI	bar	PSI	ml	fl oz
FF-06	1	1/4"	6,3	24	6,34	400	5802	1400	20305	1220	17694	2000	29008	0,01	.0003
FF-10	2	3/8"	10	46	12,15	350	5076	1100	15954	1100	15954	1500	21756	0,015	.0005
FF-12	3	1/2"	12,5	90	23,78	350	5076	1400	20305	1050	15229	1500	21756	0,02	.0007
FF-16	4A	5/8"	16	148	39,10	350	5076	1600	23206	1200	17405	1200	17405	0,02	.0007
FF-19	4	3/4"	19	212	56,00	350	5076	1200	17405	1100	15954	1300	18855	0,032	.0011
FF-25	5	1"	25	378	99,86	260	3771	1200	17405	820	11893	1040	15084	0,03	.0010
FF-38	6	1 1/2"	38	684	180,69	300	4351	1100	15954	1150	16679	150	2176	0,155	.0052
FH-51	7	2"	51	1000	264,17	150	2176	650	9427	650	9427	700	10153	0,1	.0034

The indicated pressure ratings only apply to the coupling itself and depend on the connection type.

Flow Characteristics

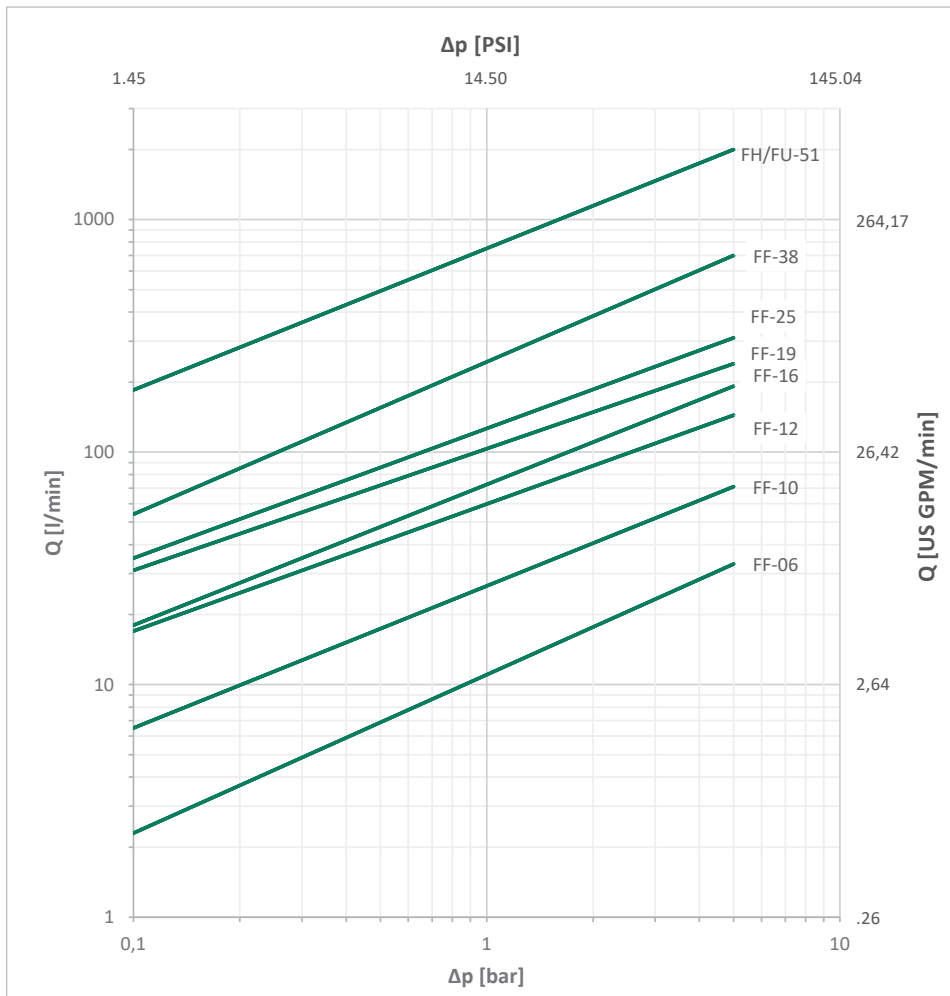

Please note: Unless otherwise stated, all flow characteristics have been determined with hydraulic oil with a kinematic viscosity of 28,8 - 35,2 mm²/s (28,8 - 35,2 cSt) and are only valid for components with non-reducing connections.



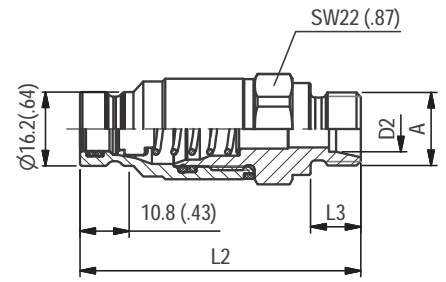
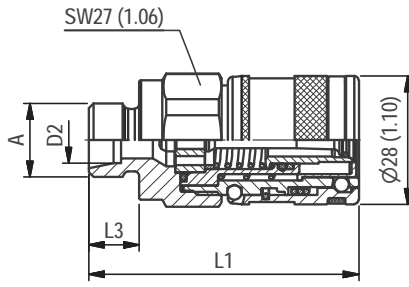

SW: Width across flats. All dimensions in mm (inch).

Series FF-06 ▪ BG 1 ▪ Nominal Size 6,3

Port A	Dimensions (^{mm} / _{in})					Female Body Ordering Codes	Weight (^{kg} / _{lbs}) ca. per 100	Male Tip Ordering Codes	Weight (^{kg} / _{lbs}) ca. per 100
	ØD2	L1	L2	L3	L4				
Female Thread according to DIN 3852 - ISO 1179-1 - ANSI B 1.20.3 - SAE J1926-1 - ISO 11926-1									
	G 1/4"	55 2.17	54 2.13		12 .47	QRC-FF-06-F-G04-BT-W3	19,82 43.70	QRC-FF-06-M-G04-S1-W3	10,05 22.16
	NPTF 1/4"-18	55 2.17	54 2.13			QRC-FF-06-F-NF04-BT-W3	19,93 43.94	QRC-FF-06-M-NF04-S1-W3	10,42 22.97
	UNF 9/16"-18	55 2.17	54,9 2.16		12,8 .50	QRC-FF-06-F-U06-BT-W3	19,36 42.68	QRC-FF-06-M-U06-S1-W3	10 22.05
Male Thread with 24° Conical Bore - Shape W according to DIN 3861									
	M14x1,5	8L	58 2.28	60,2 2.37	10 .39	QRC-FF-06-F-08L-BT-W3	17,94 39.55	QRC-FF-06-M-08L-S1-W3	10,61 23.39
			M16x1,5	10L	59 2.32	61,2 2.41	11 .43	QRC-FF-06-F-10L-BT-W3	18,13 39.97
Male Thread with 24° Conical Bore - Bulkhead - Shape W according to DIN 3861									
	M14x1,5	8L	73 2.87	75,2 2.96	25 .98	QRC-FF-06-F-08LB-BT-W3	20,31 44.78	QRC-FF-06-M-08LB-S1-W3	13 28.66
			M16x1,5	10L	74 2.91	76,2 3.00	26 1.02	QRC-FF-06-F-10LB-BT-W3	21,1 46.52

Note: The connection of the two halves of a coupling is achieved depending on the type. It is important to observe the positive engagement of plug-type couplings and the secure tightening of screw-type couplings to the limit stop of the thread. Forced or improper separation will result in malfunction of the coupling.



FF

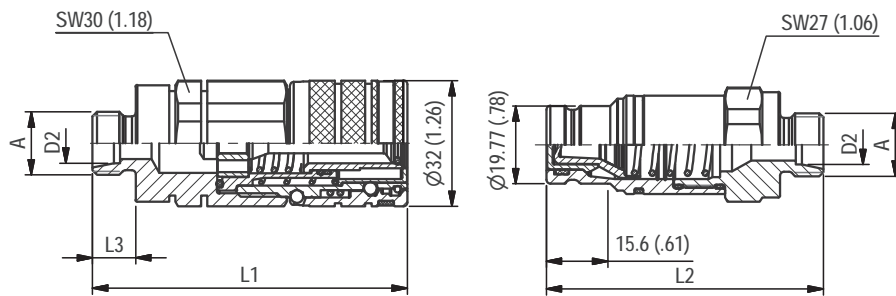

SW: Width across flats. All dimensions in mm (inch).

Series FF-10 ▪ BG 2 ▪ Nominal Size 10

Port A	Dimensions (mm/in)					Female Body Ordering Codes	Weight (^{kg} /lbs) ca. per 100	Male Tip Ordering Codes	Weight (^{kg} /lbs) ca. per 100
	ØD2	L1	L2	L3	L4				
Female Thread according to DIN 3852-2 - ISO 6149-1 - ANSI B 1.20.3-SAE J1926-1 - ISO 11926-1									
	G 3/8"	69	59,9		14	QRC-FF-10-F-G06-BT-W3	29,85 65.81	QRC-FF-10-M-G06-BP-W3	13,76 30.34
	G 1/2"	69	64,9		14	QRC-FF-10-F-G08-BT-W3	28,29 62.37	QRC-FF-10-M-G08-BP-W3	13,13 28.95
	NPTF 3/8"-18	70	62,9			QRC-FF-10-F-NF06-BT-W3	30,55 67.35	QRC-FF-10-M-NF06-BP-W3	15,02 33.11
	NPTF 1/2"-14	70	62,9			QRC-FF-10-F-NF08-BT-W3	29,29 64.57	QRC-FF-10-M-NF08-BP-W3	13,71 30.23
	UNF 3/4"-16	69	63,9		14	QRC-FF-10-F-U08-BT-W3	28,88 63.67	QRC-FF-10-M-U08-BP-W3	14,15 31.20
			2.72	2.36		.55			
Male Thread with 24° Conical Bore - Shape W according to DIN 3861									
	M16x1,5	10L	80,2	70,4	11	QRC-FF-10-F-10L-BT-W3	31,33 69.07	QRC-FF-10-M-10L-BP-W3	15,65 34.50
	M18x1,5	12L	80,2	70,4	11	QRC-FF-10-F-12L-BT-W3	31,37 69.16	QRC-FF-10-M-12L-BP-W3	15,62 34.44
	M22x1,5	15L	81	71,4	12	QRC-FF-10-F-15L-BT-W3	32 70.55	QRC-FF-10-M-15L-BP-W3	16,09 35.47
	M20x1,5	12S	81	70,4	12	QRC-FF-10-F-12S-BT-W3	30,9 68.12	QRC-FF-10-M-12S-BP-W3	16,12 35.54
	M24x1,5	16S	83	73,4	14	QRC-FF-10-F-16S-BT-W3	31,6 69.67	QRC-FF-10-M-16S-BP-W3	15,9 35.05
			3.16	2.77	.43				
Male Thread with 24° Conical Bore - Bulkhead - Shape W according to DIN 3861									
	M16x1,5	10L	86,8	85,4	26	QRC-FF-10-F-10LB-BT-W3	31,11 68.59	QRC-FF-10-M-10LB-BP-W3	18,6 41.01
	M18x1,5	12L	86,8	85,4	26	QRC-FF-10-F-12LB-BT-W3	31,61 69.69	QRC-FF-10-M-12LB-BP-W3	19,0 41.89
	M22x1,5	15L	87,8	86,4	27	QRC-FF-10-F-15LB-BT-W3	33,86 74.65	QRC-FF-10-M-15LB-BP-W3	21,13 46.58
	M20x1,5	12S	87,8	86,4	27	QRC-FF-10-F-12SB-BT-W3	33,9 74.74	QRC-FF-10-M-12SB-BP-W3	21,13 46.58
	M24x1,5	16S	89,8	88,4	29	QRC-FF-10-F-16SB-BT-W3	36,44 80.34	QRC-FF-10-M-16SB-BP-W3	25,1 55.34
			3.42	3.36	1.02				

Note: The connection of the two halves of a coupling is achieved depending on the type. It is important to observe the positive engagement of plug-type couplings and the secure tightening of screw-type couplings to the limit stop of the thread. Forced or improper separation will result in malfunction of the coupling.



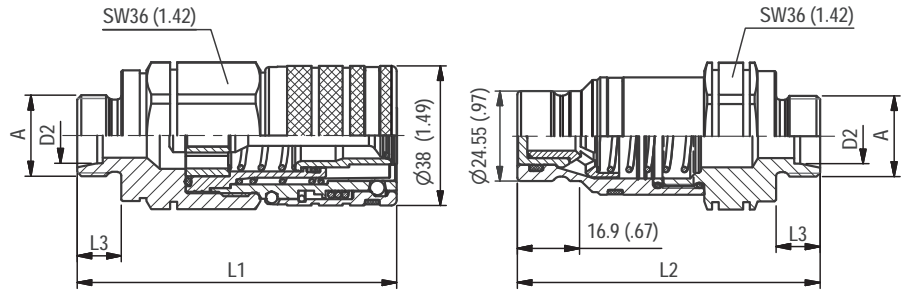

SW: Width across flats. All dimensions in mm (inch).

Series FF-12 ▪ BG 3 ▪ Nominal Size 12,5

Port A	Dimensions (^{mm} / _{in})					Female Body Ordering Codes	Weight (^{kg} / _{lbs}) ca. per 100	Male Tip Ordering Codes	Weight (^{kg} / _{lbs}) ca. per 100	
	ØD2	L1	L2	L3	L4					
Female Thread according to DIN 3852-2 - ISO 6149-1 - ANSI B 1.20.3-SAE J1926-1 - ISO 11926-1										
	G 1/2"	84 3.31	71 2.80	14 .55		QRC-FF-12-F-G08-BT-W3	51,61 113.78	QRC-FF-12-M-G08-BP-W3	28,55 62.94	
	G 3/4"	84 3.31	72 2.83	16,5 .65		QRC-FF-12-F-G12-BT-W3	48,26 106.40	QRC-FF-12-M-G12-BP-W3	26,67 58.80	
	NPTF 1/2"-14	84 3.31	71 2.80			QRC-FF-12-F-NF08-BT-W3	51,98 114.60	QRC-FF-12-M-NF08-BP-W3	29,03 64.00	
	NPTF 3/4"-14	84 3.31	72 2.83			QRC-FF-12-F-NF12-BT-W3	49,35 108.80	QRC-FF-12-M-NF12-BP-W3	27,06 59.66	
	UNF 3/4"-16	84 3.31	72 2.83	16 .63		QRC-FF-12-F-U08-BT-W3	52,05 114.75	QRC-FF-12-M-U08-BP-W3	29,79 65.68	
	UNF 7/8"-14	84 3.31	72 2.83	16,7 .66		QRC-FF-12-F-U10-BT-W3	50,62 111.60	QRC-FF-12-M-U10-BP-W3	28,32 62.43	
	UN 1" 1/16-12	84 3.31	76 2.99	19 .75		QRC-FF-12-F-U12-BT-W3	47,25 104.17	QRC-FF-12-M-U12-BP-W3	27,52 60.67	
	Male Thread with 24° Conical Bore - Shape W according to DIN 3861									
	M18x1,5	12L	86,4 3.40	81,5 3.21	11 .43		QRC-FF-12-F-12L-BT-W3	49,08 108.20	QRC-FF-12-M-12L-BP-W3	30,67 67.62
	M22x1,5	15L	87,4 3.44	82,5 3.25	12 .47		QRC-FF-12-F-15L-BT-W3	49,67 109.50	QRC-FF-12-M-15L-BP-W3	31,31 69.03
	M26x1,5	18L	87,4 3.44	82,5 3.25	12 .47		QRC-FF-12-F-18L-BT-W3	49,93 110.08	QRC-FF-12-M-18L-BP-W3	31,69 69.86
	M30x2	22L	89,4 3.52	84,5 3.33	14 .55		QRC-FF-12-F-22L-BT-W3	49,89 109.99	QRC-FF-12-M-22L-BP-W3	29,1 64.15
	M24x1,5	16S	89,4 3.52	84,5 3.33	14 .55		QRC-FF-12-F-16S-BT-W3	50,62 111.60	QRC-FF-12-M-16S-BP-W3	29,3 64.60
	M30x2	20S	91,4 3.60	86,5 3.41	16 .63		QRC-FF-12-F-20S-BT-W3	51,9 114.42	QRC-FF-12-M-20S-BP-W3	33,73 74.36
	Male Thread with 24° Conical Bore - Bulkhead - Shape W according to DIN 3861									
	M18x1,5	12L	91,5 3.60	94 3.70	26 1.02		QRC-FF-12-F-12LB-BT-W3	45,36 100.00	QRC-FF-12-M-12LB-BP-W3	32,32 71.25
	M22x1,5	15L	92,5 3.64	95 3.74	27 1.06		QRC-FF-12-F-15LB-BT-W3	47,72 105.20	QRC-FF-12-M-15LB-BP-W3	34,67 76.43
	M26x1,5	18L	92,5 3.64	95 3.74	27 1.06		QRC-FF-12-F-18LB-BT-W3	50,9 112.22	QRC-FF-12-M-18LB-BP-W3	37,87 83.49
	M30x2	22L	99,5 3.92	102 4.02	34 1.34		QRC-FF-12-F-22LB-BT-W3	54,78 120.77	QRC-FF-12-M-22LB-BP-W3	41,9 92.37
	M24x1,5	16S	94,5 3.72	97 3.82	29 1.14		QRC-FF-12-F-16SB-BT-W3	49,75 109.68	QRC-FF-12-M-16SB-BP-W3	37,25 82.12
	M30x2	20S	101,5 4.00	104 4.09	36 1.42		QRC-FF-12-F-20SB-BT-W3	57,59 126.96	QRC-FF-12-M-20SB-BP-W3	44,68 98.50

Note: The connection of the two halves of a coupling is achieved depending on the type. It is important to observe the positive engagement of plug-type couplings and the secure tightening of screw-type couplings to the limit stop of the thread. Forced or improper separation will result in malfunction of the coupling.



FF

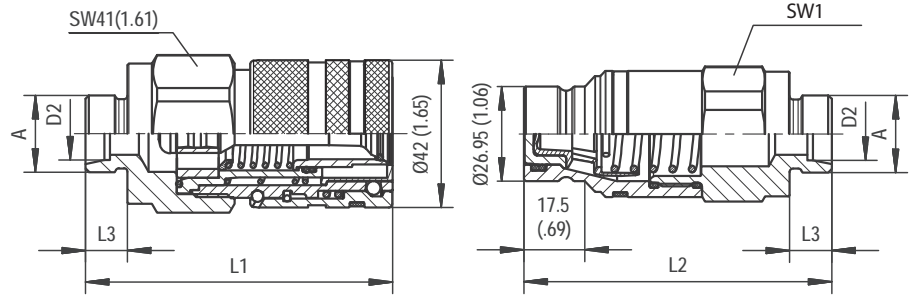

SW: Width across flats. All dimensions in mm (inch).

Series FF-16 ▪ BG 4A ▪ Nominal Size 16

Port A	Dimensions (mm/in)						Female Body	Weight (kg/lbs) ca. per 100	Male Tip	Weight (kg/lbs) ca. per 100
	ØD2	L1	L2	L3	L4	SW1	Ordering Codes		Ordering Codes	
Female Thread according to DIN 3852-2 - ANSI B 1.20.3 - SAE J1926-1 - ISO 11926-1										
	G 3/4"	87,7 3.45	73 2.87		18 .71	36 1.42	QRC-FF-16-F-G12-BT-W3	67,44 148.68	QRC-FF-16-M-G12-BP-W3	31,05 68.45
	G 1"	89,7 3.53	80,3 3.16		20 .79	41 1.61	QRC-FF-16-F-G16-BT-W3	63,88 140.83	QRC-FF-16-M-G16-BP-W3	37,71 83.14
	NPTF 3/4"-14	87,7 3.45	76 2.99			36 1.42	QRC-FF-16-F-NF12-BT-W3	68,3 150.58	QRC-FF-16-M-NF12-BP-W3	33,73 74.36
	UN 1" 1/16-12	87,7 3.45	78 3.07		19 .75	36 1.42	QRC-FF-16-F-U12-BT-W3	66,19 145.92	QRC-FF-16-M-U12-BP-W3	33,14 73.06
Male Thread with 24° Conical Bore - Shape W according to DIN 3861										
	M22x1,5	15L	87 3.43	88 3.46	12 .47	36 1.42	QRC-FF-16-F-15L-BT-W3	60,80 134.04	QRC-FF-16-M-15L-BP-W3	36,60 80.69
	M26x1,5	18L	87 3.43	88 3.46	12 .47	36 1.42	QRC-FF-16-F-18L-BT-W3	61,3 135.14	QRC-FF-16-M-18L-BP-W3	38,82 85.58
	M30x2	22L	89,7 3.53	90 3.54	14 .55	36 1.42	QRC-FF-16-F-22L-BT-W3	62,54 137.88	QRC-FF-16-M-22L-BP-W3	39,25 86.53
	M24x1,5	16S	89 3.50	90 3.54	14 .55	36 1.42	QRC-FF-16-F-16S-BT-W3	61,80 136.25	QRC-FF-16-M-16S-BP-W3	37,4 82.45
	M30x2	20S	91 3.58	92 3.62	16 .63	36 1.42	QRC-FF-16-F-20S-BT-W3	63,30 139.55	QRC-FF-16-M-20S-BP-W3	43,9 96.78
	M36x2	25S	93 3.66	94 3.70	18 .71	41 1.61	QRC-FF-16-F-25S-BT-W3	65,60 144.62	QRC-FF-16-M-25S-BP-W3	47,2 104.06
Male Thread with 24° Conical Bore - Bulkhead - Shape W according to DIN 3861										
	M22x1,5	15L	102 4.02	103 4.06	27 1.06	36 1.42	QRC-FF-16-F-15LB-BT-W3	63,6 140.21	QRC-FF-16-M-15LB-BP-W3	39,5 87.08
	M26x1,5	18L	102,7 4.04	103 4.06	27 1.06	36 1.42	QRC-FF-16-F-18LB-BT-W3	69,77 153.82	QRC-FF-16-M-18LB-BP-W3	46,56 102.65
	M30x2	22L	109 4.29	110 4.33	34 1.34	36 1.42	QRC-FF-16-F-22LB-BT-W3	68,1 150.14	QRC-FF-16-M-22LB-BP-W3	43,9 96.78
	M24x1,5	16S	104 4.09	105 4.13	29 1.14	36 1.42	QRC-FF-16-F-16SB-BT-W3	65,4 144.18	QRC-FF-16-M-16SB-BP-W3	41,4 91.27
	M30x2	20S	111 4.37	112 4.41	36 1.42	36 1.42	QRC-FF-16-F-20SB-BT-W3	71 156.53	QRC-FF-16-M-20SB-BP-W3	46,9 103.4
	M36x2	25S	113 4.45	114 4.49	38 1.50	41 1.61	QRC-FF-16-F-25SB-BT-W3	76,2 167.99	QRC-FF-16-M-25SB-BP-W3	58,2 128.31

Note: The connection of the two halves of a coupling is achieved depending on the type. It is important to observe the positive engagement of plug-type couplings and the secure tightening of screw-type couplings to the limit stop of the thread. Forced or improper separation will result in malfunction of the coupling.



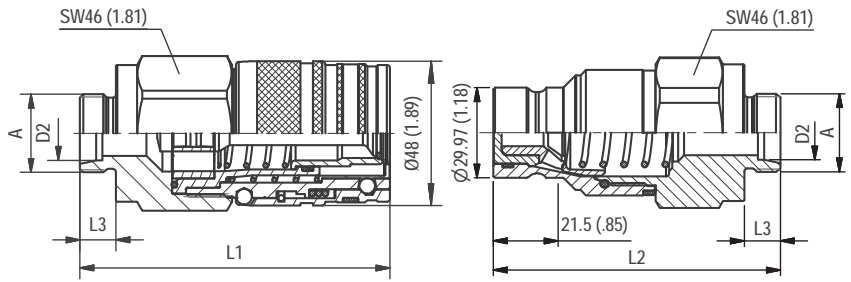

SW: Width across flats. All dimensions in mm (inch).

Series FF-19 • BG 4 • Nominal Size 19

Port A	Dimensions (mm/in)					Female Body Ordering Codes	Weight (^{kg} /lbs) ca. per 100	Male Tip Ordering Codes	Weight (^{kg} /lbs) ca. per 100
	ØD2	L1	L2	L3	L4				
Female Thread according to DIN 3852-2 - ISO 6149-1 - ANSI B 1.20.3- SAE J1926-1 - ISO 11926-1									
	G 3/4"	98,7 3.89	84 3.31		16,5 .65	QRC-FF-19-F-G12-BT-W3	96,92 213.67	QRC-FF-19-M-G12-BP-W3	56,49 124.54
	G 1"	98,7 3.89	84 3.31		18 .71	QRC-FF-19-F-G16-BT-W3	91,52 201.77	QRC-FF-19-M-G16-BP-W3	50,84 112.08
	NPTF 3/4"-14	98,7 3.89	84 3.31			QRC-FF-19-F-NF12-BT-W3	97,41 214.75	QRC-FF-19-M-NF12-BP-W3	57,27 126.26
	NPTF 1"-11 1/2	98,7 3.89	84 3.31			QRC-FF-19-F-NF16-BT-W3	92,98 204.99	QRC-FF-19-M-NF16-BP-W3	53,22 117.33
	UN 1" 1/16-12	98,7 3.89	84 3.31		19 .75	QRC-FF-19-F-U12-BT-W3	96,82 213.45	QRC-FF-19-M-U12-BP-W3	56,6 124.78
	UN 1" 5/16-12	98,7 3.89	84 3.31		19 .75	QRC-FF-19-F-U16-BT-W3	91,03 200.69	QRC-FF-19-M-U16-BP-W3	30,98 68.30
	Male Thread with 24° Conical Bore - Shape W according to DIN 3861								
	M26x1,5	18L 4.06	103 3.78	96 .47	12	QRC-FF-19-F-18L-BT-W3	95,19 209.86	QRC-FF-19-M-18L-BP-W3	64,11 141.34
	M30x2	22L 4.13	105 3.86	98 .55	14	QRC-FF-19-F-22L-BT-W3	95,14 209.75	QRC-FF-19-M-22L-BP-W3	63,26 139.46
	M36x2	28L 4.13	105 3.86	98 .55	14	QRC-FF-19-F-28L-BT-W3	94,37 208.05	QRC-FF-19-M-28L-BP-W3	58,1 128.09
	M30x2	20S 4.21	107 3.94	100 .63	16	QRC-FF-19-F-20S-BT-W3	93,1 205.25	QRC-FF-19-M-20S-BP-W3	62,5 137.79
	M36x2	25S 4.29	109 4.02	102 .71	18	QRC-FF-19-F-25S-BT-W3	98,78 217.77	QRC-FF-19-M-25S-BP-W3	63,2 139.33
	M42x2	30S 4.37	111 4.09	104 .79	20	QRC-FF-19-F-30S-BT-W3	96,1 211.86	QRC-FF-19-M-30S-BP-W3	63,7 140.43
	Male Thread with 24° Conical Bore - Bulkhead - Shape W according to DIN 3861								
	M26x1,5	18L 4.92	125 4.65	118 1.34	34	QRC-FF-19-F-18LB-BT-W3	104,87 231.20	QRC-FF-19-M-18LB-BP-W3	73,8 162.70
	M30x2	22L 4.92	125 4.65	118 1.34	34	QRC-FF-19-F-22LB-BT-W3	106,32 234.40	QRC-FF-19-M-22LB-BP-W3	76,5 168.65
	M36x2	28L 4.92	125 4.65	118 1.34	34	QRC-FF-19-F-28LB-BT-W3	109,03 240.37	QRC-FF-19-M-28LB-BP-W3	76,18 167.95
	M30x2	20S 5.08	129 4.80	122 1.50	38	QRC-FF-19-F-20SB-BT-W3	111,8 246.48	QRC-FF-19-M-20SB-BP-W3	79,15 174.50
	M36x2	25S 5.08	129 4.80	122 1.50	38	QRC-FF-19-F-25SB-BT-W3	115,61 254.88	QRC-FF-19-M-25SB-BP-W3	83,5 184.09
	M42x2	30S 5.16	131 4.88	124 1.50	38	QRC-FF-19-F-30SB-BT-W3	110,1 242.73	QRC-FF-19-M-30SB-BP-W3	77,8 171.52

Note: The connection of the two halves of a coupling is achieved depending on the type. It is important to observe the positive engagement of plug-type couplings and the secure tightening of screw-type couplings to the limit stop of the thread. Forced or improper separation will result in malfunction of the coupling.



FF

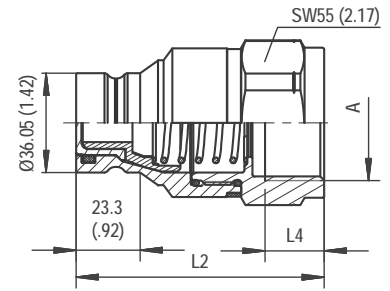
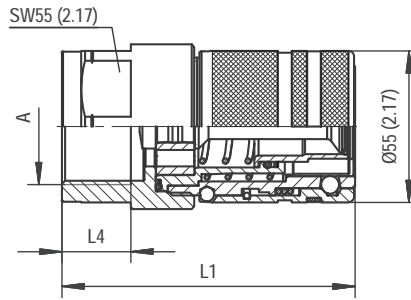

SW: Width across flats. All dimensions in mm (inch).

Series FF-25 ▪ BG 5 ▪ Nominal Size 25

Port A	Dimensions (mm/in)					Female Body	Weight (^{kg} /lbs) ca. per 100	Male Tip	Weight (^{kg} /lbs) ca. per 100
	ØD2	L1	L2	L3	L4	Ordering Codes		Ordering Codes	
Female Thread according to DIN 3852-2 - ANSI B 1.20.3 - SAE J1926-1 - ISO 11926-1									
	G 1"	106,5	90		20	QRC-FF-25-F-G16-BT-W3	145,76 321.35	QRC-FF-25-M-G16-BP-W3	90,24 198.95
		4.19	3.54		.79				
	G 1" 1/4	106,5	90		20	QRC-FF-25-F-G20-BT-W3	135,55 298.84	QRC-FF-25-M-G20-BP-W3	80,08 176.55
		4.19	3.54		.79				
	G 1" 1/2	106,5	95,7		25	QRC-FF-25-F-G24-BT-W3	125,2 276.02	QRC-FF-25-M-G24-BP-W3	77,92 171.78
		4.19	3.77		.98				
	NPTF 1" 11 1/2	106,5	90			QRC-FF-25-F-NF16-BT-W3	143 315.26	QRC-FF-25-M-NF16-BP-W3	91,34 201.37
		4.19	3.54						
	NPTF 1" 1/4-11 1/2	106,5	90			QRC-FF-25-F-NF20-BT-W3	139,34 307.19	QRC-FF-25-M-NF20-BP-W3	73,6 162.26
		4.19	3.54						
	UN 1" 5/16 - 12	106,5	90		20	QRC-FF-25-F-U16-BT-W3	144,6 318.79	QRC-FF-25-M-U16-BP-W3	88,67 195.48
		4.19	3.54		.79				
	UN 1" 5/8 - 12	106,5	90		19	QRC-FF-25-F-U20-BT-W3	135,1 297.84	QRC-FF-25-M-U20-BP-W3	80 176.37
		4.19	3.54		.75				

Note: The connection of the two halves of a coupling is achieved depending on the type. It is important to observe the positive engagement of plug-type couplings and the secure tightening of screw-type couplings to the limit stop of the thread. Forced or improper separation will result in malfunction of the coupling.



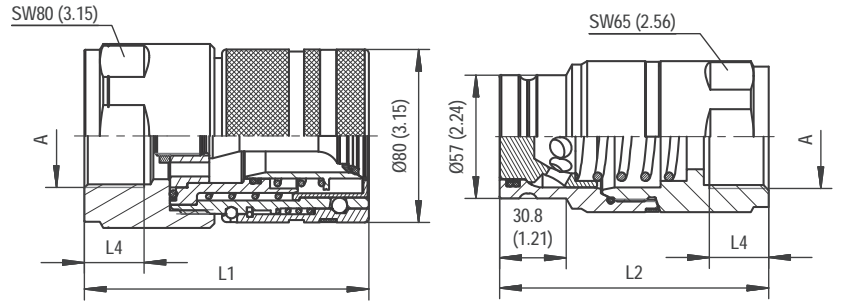

SW: Width across flats. All dimensions in mm (inch).

Series FF-38 • BG 6 • Nominal Size 38

Port A	Dimensions (mm/in)					Female Body Ordering Codes	Weight (^{kg} /lbs) ca. per 100	Male Tip Ordering Codes	Weight (^{kg} /lbs) ca. per 100
	ØD2	L1	L2	L3	L4				
Female Thread according to ISO 3852-2 - ANSI B 1.20.3 - SAE J1926-1 - ISO 11926-1									
	G 1 1/4"	131,6 5.18	124,6 4.91		21,5 .85	QRC-FF-38-F-G20-S1-W3	388,40 856.28	QRC-FF-38-M-G20-BT-W3	218,60 481.93
	G 1 1/2"	131,6 5.18	124,6 4.91		23 .89	QRC-FF-38-F-G24-S1-W3	379,10 835.77	QRC-FF-38-M-G24-BT-W3	209,90 462.75
	NPTF 1" 1/4- 11 1/2	131,6 5.18	124,6 4.91			QRC-FF-38-F-NF20-S1-W3	390,50 860.91	QRC-FF-38-M-NF20-BT-W3	221,10 487.44
	NPTF 1" 1/2- 11 1/2	131,6 5.18	124,6 4.91			QRC-FF-38-F-NF24-S1-W3	381,20 840.40	QRC-FF-38-M-NF24-BT-W3	216,80 477.96
	UN 1" 5/8-12	131,6 5.18	124,6 4.91		19 .75	QRC-FF-38-F-U20-S1-W3	387,70 854.73	QRC-FF-38-M-U20-BT-W3	218,50 481.71
	UN 1" 7/8-12	131,6 5.18	124,6 4.91		19 .75	QRC-FF-38-F-U24-S1-W3	376,10 829.16	QRC-FF-38-M-U24-BT-W3	210,30 463.63

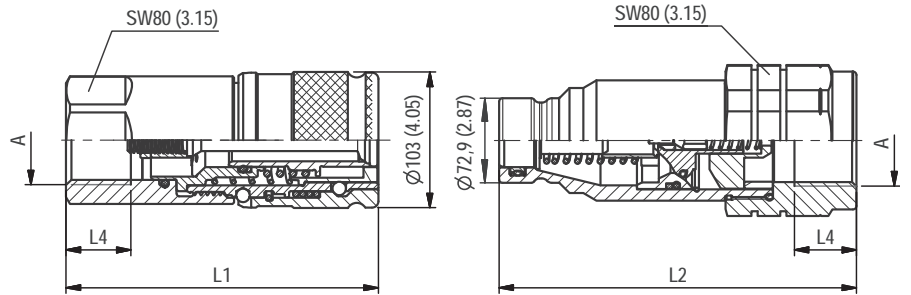

SW: Width across flats. All dimensions in mm (inch).

Series FH/FU 51 • BG 7 • Nominal Size 51

Port A	Dimensions (mm/in)					Female Body Ordering Codes	Weight (^{kg} /lbs) ca. per 100	Male Tip Ordering Codes	Weight (^{kg} /lbs) ca. per 100
	ØD2	L1	L2	L3	L4				
Female Thread according to DIN 3852-2-A - ANSI B 1.20.3									
	G 2"	147,4	173		24	QRC-FH-51-F-G32-BT-W66	550	QRC-FU-51-M-G32-BT-W66	489
		5,80	6,81		.94		1212.54		1078.06
	NPTF 2" -11 1/2	147,4	173			QRC-FH-51-F-NF32-BT-W66	540	QRC-FU-51-M-NF32-BT-W66	479
		5,80	6,81				1190.50		1056.01

Note: The connection of the two halves of a coupling is achieved depending on the type. It is important to observe the positive engagement of plug-type couplings and the secure tightening of screw-type couplings to the limit stop of the thread. Forced or improper separation will result in malfunction of the coupling.



Series FF - Dust Protection

FF

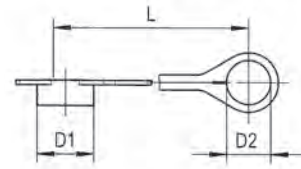
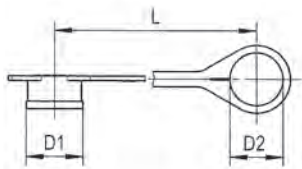

Dimensions (mm/in)			Material	Dust Cap for Male Tip
D1	D2	L		Ordering Codes
28	24	170	Plastic (Colour: Red)	QRC-FF-06-DM-22-K-RD
1.10	.94	6.69		
32	27	115	Plastic (Colour: Red)	QRC-FF-10-DM-27-K-RD
1.26	1.06	4.53		
38	35,5	135	Plastic (Colour: Red)	QRC-FF-12-DM-36-K-RD
1.50	1.40	5.31		
42	30	220	Plastic (Colour: Red)	QRC-FF-16-DM-30-K-RD
1.65	1.18	8.66		
48	45,5	150	Plastic (Colour: Red)	QRC-FF-19-DM-46-K-RD
1.89	1.79	5.91		
46	51	290	Plastic (Colour: Red)	QRC-FF-25-DM-51-K-RD
1.81	2.01	11.42		

Dimensions (mm/in)			Material	Dust Plug for Female Body
D1	D2	L		Ordering Codes
34	24	170	Plastic (Colour: Red)	QRC-FF-06-DF-24-K-RD
1.34	.94	6.69		
38	30	130	Plastic (Colour: Red)	QRC-FF-10-DF-30-K-RD
1.50	1.18	5.12		
45	35,5	140	Plastic (Colour: Red)	QRC-FF-12-DF-36-K-RD
1.77	1.40	5.51		
46	30	225	Plastic (Colour: Red)	QRC-FF-16-DF-30-K-RD
1.81	1.18	8.86		
52	45,5	170	Plastic (Colour: Red)	QRC-FF-19-DF-46-K-RD
2.05	1.79	6.69		
62	51	290	Plastic (Colour: Red)	QRC-FF-25-DF-51-K-RD
2.44	2.01	11.42		

In addition to the standard colours as stated above, plastic dust caps are also available in blue, green, yellow and black. Please use the color codes BU, GN, YE and BK respectively instead of RD.

Note: The connection of the two halves of a coupling is achieved depending on the type. It is important to observe the positive engagement of plug-type couplings and the secure tightening of screw-type couplings to the limit stop of the thread. Forced or improper separation will result in malfunction of the coupling.



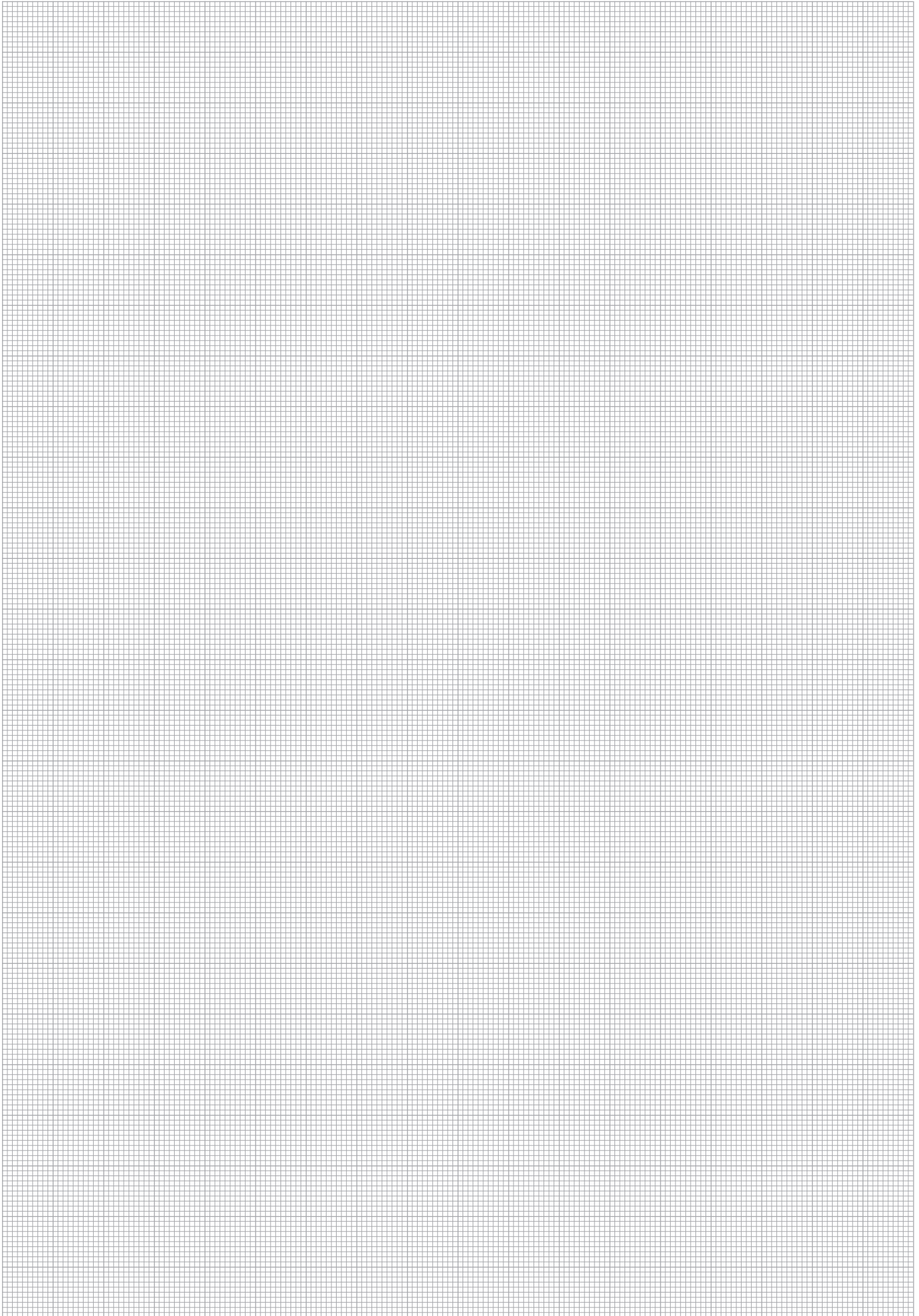

FF

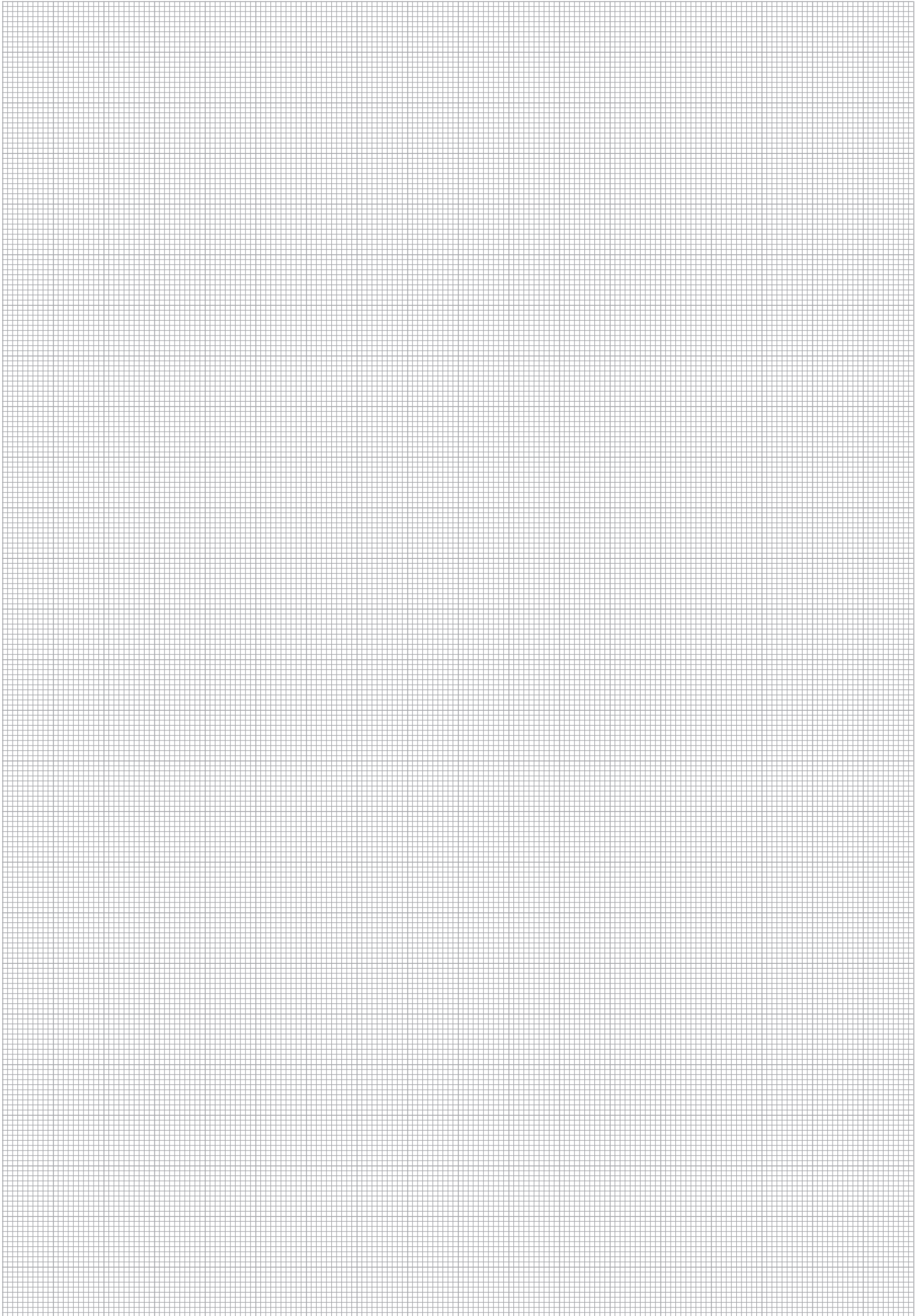

Series FC • Carbon Steel
Product Description

Flat Face Push-to-Connect Couplings of the FC Series from STAUFF consist of a male tip which is designed according to ISO 16028 and are compatible with couplings of this type.

In combination with Female Bodies of the STAUFF FF Series, Male Tips of the FC Series are used for quick and easy connection (push) and disconnection of tubes, pipes and hoses by hand, i.e. without tools.

The Series was developed for coupling Under pressure and is available in the following nominal sizes 10, 12, 16, 19, 25 (3/8" - 1").

A maximum operating pressure of 350 bar (5076 PSI) can also be achieved in combination with Female Bodies of the STAUFF FF Series (size 10, 12, 16, 19).

The proven design is suitable for use in agricultural and forestry machinery, construction machinery and hydraulic attachments.

FC
Features

- Flat Face
- Coupling made from carbon steel with Zinc/Nickel surface coating
- Connection Under pressure allowed with STAUFF Female Bodies of the QRC-FF Series with Male Tips of the QRC-FC Series
- ISO Interchange acc. to ISO 16028
- Maximum working pressure of 350 bar (5076 PSI) in combination with Female Bodies of the STAUFF FF Series (sizes 10, 12, 16, 19)
- Can be connected by hand while having a residual pressure up to 250 bar (3626 PSI) on the male side in combination with Female Bodies of the QRC-FF Series
- Powerful flow characteristics with minimal pressure drop
- Heavy internal components

Applications

Agricultural and Forestry Machinery

Construction Machinery

Industrial Hydraulic
Top Features

Zinc/Nickel coating

Designed for secure connection

Connect Under pressure

Series FC - Carbon Steel

Material	Carbon Steel
Surface Finishing	Zink/Nickel
Standard Seal Material(s)	NBR (Buna-N®), PTFE, PU, POM
Working Temperature	-25° C ... +100° C / -13° F ... +212° F
Valve Design	Flat Face
Connection	Push
Disconnection	-
Connect Under Pressure	up to 250 bar (3626 PSI) allowed (Only Residual Pressure)
Disconnect Under Pressure	-
Application	Agricultural and Forestry Machinery, Construction Machinery, Industrial Hydraulic
ISO Interchange	-



FC

Technical Data

Series	BG	DN Zoll Inch	DN metric ISO 4397	Q _{max} l/min	US GPM	Working Pressure Connected		Male Tip		Spillage	
						bar	PSI	bar	PSI	ml	fl oz
FC-10	2	3/8"	10	46	12.15	350	5076	350	5076	0,013	.0004
FC-12	3	1/2"	12,5	90	23.77	350	5076	350	5076	0,013	.0004
FC-16	4A	5/8"	16	148	39.09	350	5076	350	5076	0,03	.001
FC-19	4	3/4"	19	200	52.83	350	5076	350	5076	0,05	.002
FC-25	5	1"	25	378	99.86	350	5076	350	5076	0,03	.001

Series	Bursting Pressure Connected		Male Tip		Maximum pressure for connecting	
	bar	PSI	bar	PSI	bar	PSI
FC-10	1300	18854	1800	26107	250	3626
FC-12	1400	20305	1500	21756	250	3626
FC-16	1400	20305	1400	20305	250	3626
FC-19	1400	20305	1400	20305	250	3626
FC-25	1150	16679	1400	20305	250	3626

Note:

Working pressure only in connection with STAUFF Female Bodies of the QRC-FF Series with Male Tips of the QRC-FC Series.

Bursting pressure connected only in connection with STAUFF Female Bodies of the QRC-FF Series with Male Tips of the QRC-FC Series.

The indicated pressure ratings only apply to the coupling itself and depend on the connection type.

Flow Characteristics

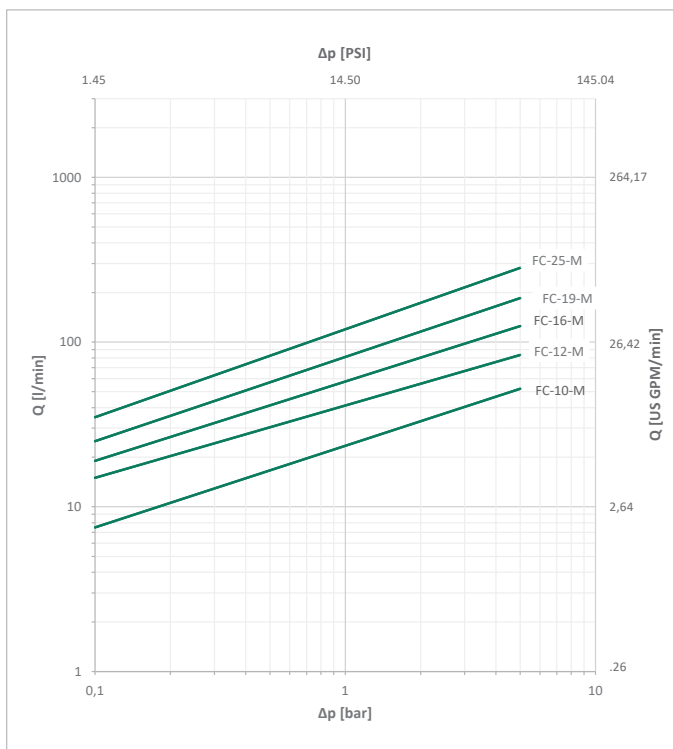

Please note: Unless otherwise stated, all flow characteristics have been determined with hydraulic oil with a kinematic viscosity of 28,8 - 35,2 mm²/s (28,8 - 35,2 cSt) and are only valid for components with non-reducing connections.



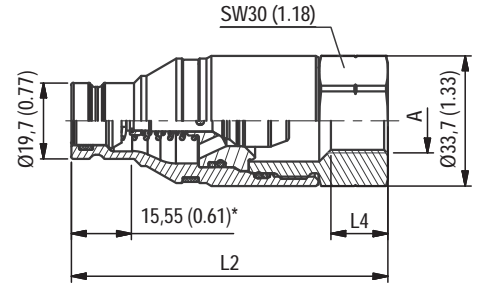

* Insertion Male Tip
All dimensions in mm (inch).

Series FC-10 ▪ BG 2 ▪ Nominal Size 10

Port A	Dimensions (mm/in)					Female Body	Weight (^{kg} /lbs) ca. per 100	Male Tip Ordering Codes	Weight (^{kg} /lbs) ca. per 100
	ØD2	L1	L2	L3	L4				
Female Thread according to DIN 3852-2 - ANSI B 1.20.3 - SAE J1926-1 - ISO 11926-1									
	G 3/8"	69	82		13	Connection with STAUFF Female Bodies of the QRC-FF Series with Male Tips of the QRC-FC Series.		QRC-FC-10-M-G06-S5-W3	31,2
		2.72	3.23		.51				68.8
	G 1/2"	69	82		15			QRC-FC-10-M-G08-S5-W3	29,7
		2.72	3.23		.59				65.5
	NPTF 3/8" -18	70	82					QRC-FC-10-M-NF06-S5-W3	31
		7.76	3.23						68.4
	NPTF 1/2" -14	69	82					QRC-FC-10-M-NF08-S5-W3	29,7
	2.72	3.23					65.5		
UNF 9/16" -18	69	82		13		QRC-FC-10-M-U06-S5-W3	31,4		
	2.72	3.23		.51			69.2		
UNF 3/4" -16	69	82		14.5		QRC-FC-10-M-U08-S5-W3	30		
	2.72	3.23		.57			66.1		

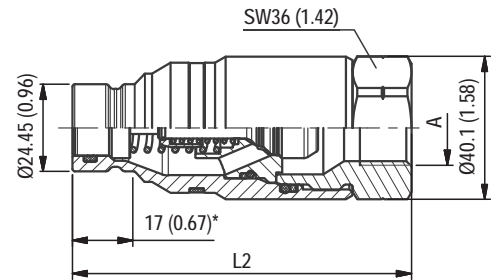

* Insertion Male Tip
All dimensions in mm (inch).

Series FC-12 ▪ BG 3 ▪ Nominal Size 12,5

Port A	Dimensions (mm/in)					Female Body	Weight (^{kg} /lbs) ca. per 100	Male Tip Ordering Codes	Weight (^{kg} /lbs) ca. per 100
	ØD2	L1	L2	L3	L4				
Female Thread according to DIN 3852-2 - ANSI B 1.20.3 - SAE J1926-1 - ISO 11926-1									
	G 1/2"	84	95		14,5	Connection with STAUFF Female Bodies of the QRC-FF Series with Male Tips of the QRC-FC Series.		QRC-FC-12-M-G08-S5-W3	51,9
		3.31	3.74		.57				114.4
	G 3/4"	84	96		16,5			QRC-FC-12-M-G12-S5-W3	49,5
		3.31	3.77		.64				109.1
	NPTF 1/2" -14	84	95					QRC-FC-12-M-NF08-S5-W3	52,3
		3.31	3.74						115.3
	NPTF 3/4" -14	84	95					QRC-FC-12-M-NF12-S5-W3	49,7
		3.31	3.74						109.6
UNF 3/4" -16	84	95		16		QRC-FC-12-M-U08-S5-W3	52,3		
	3.31	3.74		.63			115.3		
UNF 7/8" -14	84	95		17		QRC-FC-12-M-U10-S5-W3	51		
	3.31	3.74		.75			112.4		
UN 1" 1/16 -12	84	97		18		QRC-FC-12-M-U12-S5-W3	49,3		
	3.31	3.82		.75			108.7		

Note: The connection of the two halves of a coupling is achieved depending on the type. It is important to observe the positive engagement of plug-type couplings and the secure tightening of screw-type couplings to the limit stop of the thread. Forced or improper separation will result in malfunction of the coupling.



FC

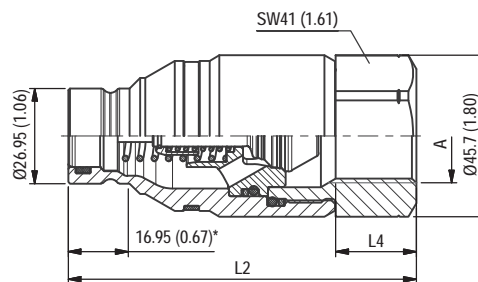

* Insertion Male Tip
All dimensions in mm (inch).

Series FC-16 ▪ BG 4A ▪ Nominal Size 16

Port A	Dimensions (mm/in)					Female Body	Weight (kg/lbs) ca. per 100	Male Tip Ordering Codes	Weight (kg/lbs) ca. per 100
	ØD2	L1	L2	L3	L4				
Female Thread according to DIN 3852-2 - ANSI B 1.20.3 - SAE J1926-1 - ISO 11926-1									
	G 3/4"		98,5		22	Connection with STAUFF Female Bodys of the QRC-FF Series with Male Tips of the QRC-FC Series.		QRC-FC-16-M-G12-S5-W3	70
			3.88		.87				154.3
	NPTF 3/4" -14		101,5					QRC-FC-16-M-NF12-S5-W3	68
		3.98						149.9	
UN 1" 1/16 -12		101,5		19			QRC-FC-16-M-U12-S5-W3	69,6	
		3.98		.75				153.4	

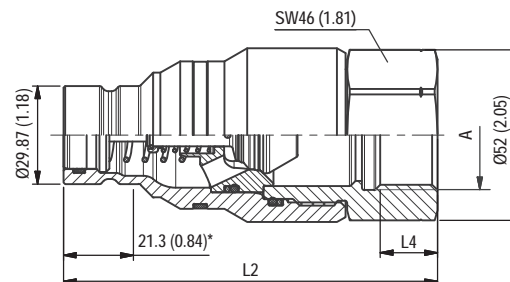

* Insertion Male Tip
All dimensions in mm (inch).

Series FC-19 ▪ BG 4 ▪ Nominal Size 19

Port A	Dimensions (mm/in)					Female Body	Weight (kg/lbs) ca. per 100	Male Tip Ordering Codes	Weight (kg/lbs) ca. per 100
	ØD2	L1	L2	L3	L4				
Female Thread according to DIN 3852-2 - ANSI B 1.20.3 - SAE J1926-1 - ISO 11926-1									
	G 3/4"		114		16,5	Connection with STAUFF Female Bodys of the QRC-FF Series with Male Tips of the QRC-FC Series.		QRC-FC-19-M-G12-S5-W3	102,8
			4.49		.24				226.6
	G 1"		114		17,5			QRC-FC-19-M-G16-S5-W3	95,5
			4.49		.69				210.5
	NPTF 3/4"-14		114					QRC-FC-19-M-NF12-S5-W3	101
			4.49						222.7
	NPTF 1"-11 1/2		114					QRC-FC-19-M-NF16-S5-W3	96,3
			4.49						212.3
	UN 1" 1/16-12		114		19			QRC-FC-19-M-U12-S5-W3	103,7
			4.49		.75				228.6
UN 1" 5/16-12		114		19		QRC-FC-19-M-U16-S5-W3	96,4		
		4.49		.75			212.5		

Note: The connection of the two halves of a coupling is achieved depending on the type. It is important to observe the positive engagement of plug-type couplings and the secure tightening of screw-type couplings to the limit stop of the thread. Forced or improper separation will result in malfunction of the coupling.



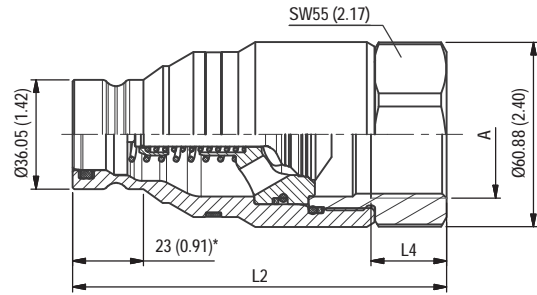

* Insertion Male Tip
All dimensions in mm (inch).

Series FC-25 ▪ BG 5 ▪ Nominal Size 25

Port A	Dimensions (mm/in)					Female Body	Weight (kg/lbs) ca. per 100	Male Tip Ordering Codes	Weight (kg/lbs) ca. per 100
	ØD2	L1	L2	L3	L4				
Female Thread according to DIN 3852-2 - ANSI B 1.20.3 - SAE J1926-1 - ISO 11926-1									
	G 1" 1/4		123,5		25	Connection with STAUFF Female Bodies of the QRC-FF Series with Male Tips of the QRC-FC Series.		QRC-FC-25-M-G20-S5-W3	134,9
			4,86		.98				297,4
	NPTF 1" 1/4-11 1/2		126,4					QRC-FC-25-M-NF20-S5-W3	137,1
		4,98						302,3	
		126,4		20				137	
		4,98		.79			QRC-FC-25-M-U20-S5-W3	302	

Note: The connection of the two halves of a coupling is achieved depending on the type. It is important to observe the positive engagement of plug-type couplings and the secure tightening of screw-type couplings to the limit stop of the thread. Forced or improper separation will result in malfunction of the coupling.



Series FC • Dust Protection

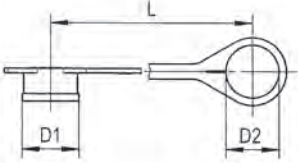

FC

Dimensions (^{mm} / _{in})			Material	Dust Cap for Male Tip
D1	D2	L		Ordering Codes
28	24	170	Plastic (Colour: Red)	QRC-FF-06-DM-22-K-RD
1.10	.94	6.69		
32	27	115	Plastic (Colour: Red)	QRC-FF-10-DM-27-K-RD
1.26	1.06	4.53		
38	35,5	135	Plastic (Colour: Red)	QRC-FF-12-DM-36-K-RD
1.50	1.40	5.31		
42	30	220	Plastic (Colour: Red)	QRC-FF-16-DM-30-K-RD
1.65	1.18	8.66		
48	45,5	150	Plastic (Colour: Red)	QRC-FF-19-DM-46-K-RD
1.89	1.79	5.91		
46	51	290	Plastic (Colour: Red)	QRC-FF-25-DM-51-K-RD
1.81	2.01	11.42		

In addition to the standard colours as stated above,
 plastic dust caps are also available in blue, green, yellow and black.
 Please use the color codes BU, GN, YE and BK respectively instead of RD.



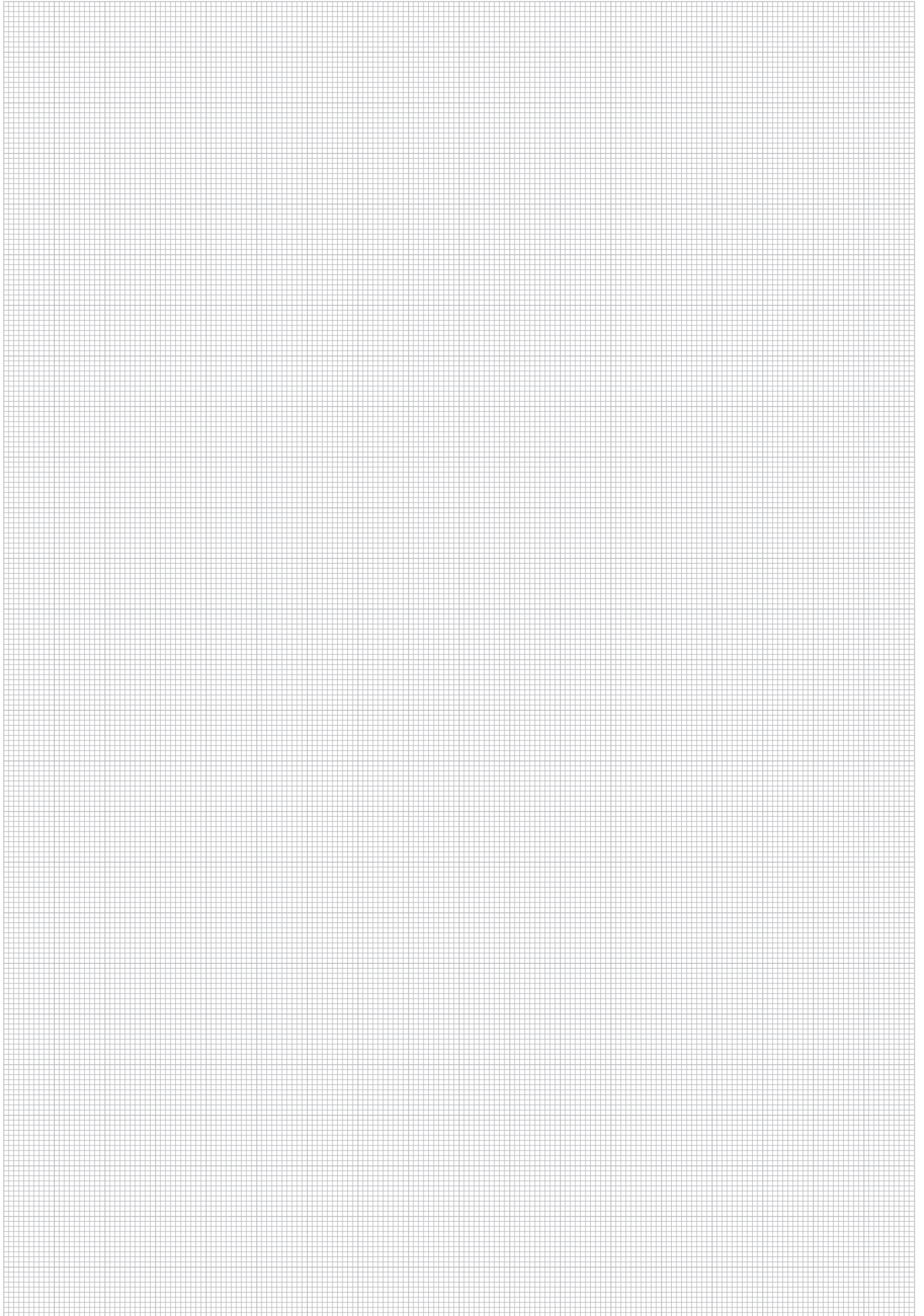

FC

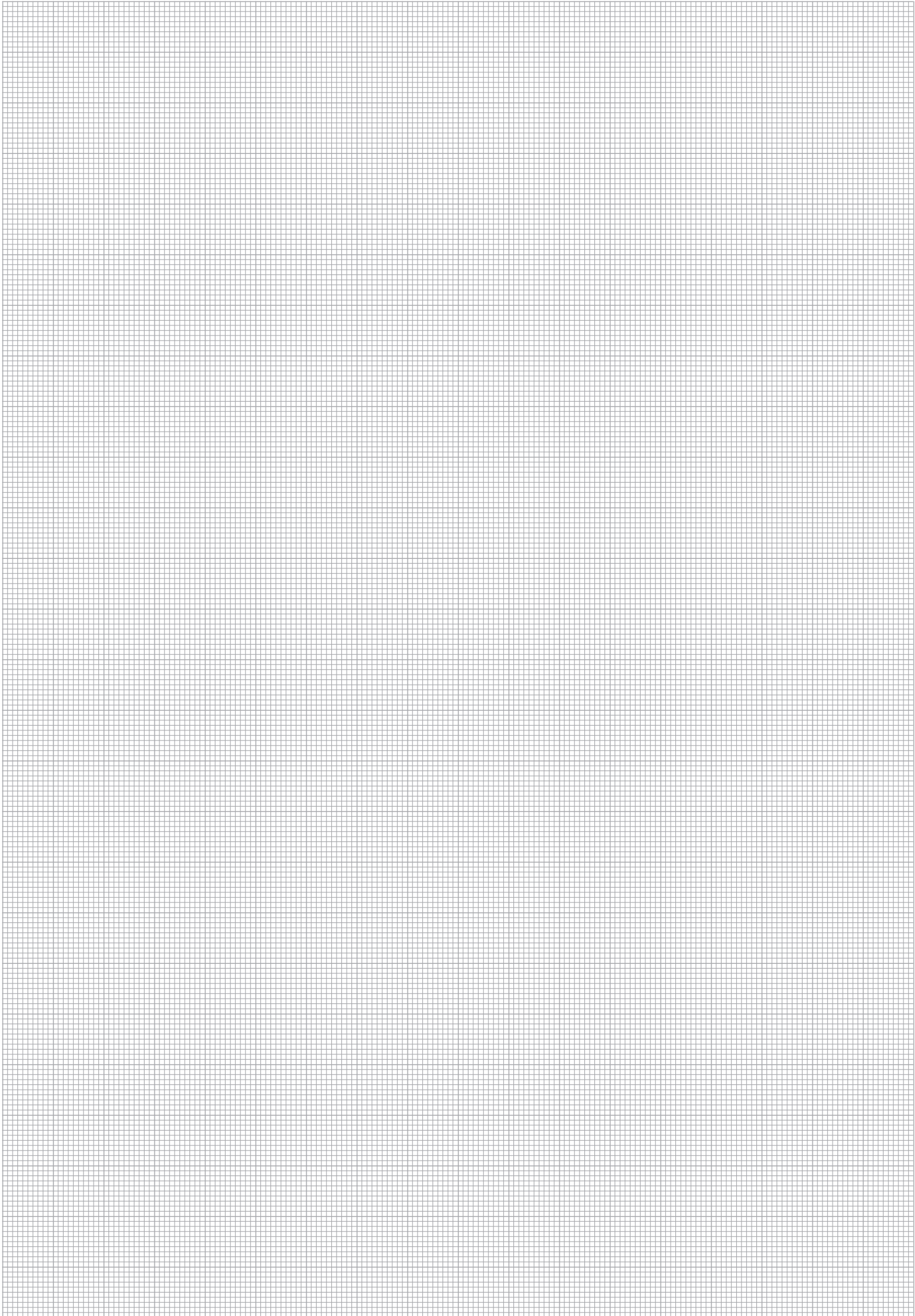

Series FH • Stainless Steel

Product Description

Flat Face Push-to-Connect Couplings of the FH Series made of stainless steel from STAUFF consist of a male tip and a female body which are used for quick and easy connection (push) and disconnection of tubes, pipes and hoses by hand, i.e. without tools.

The Series was developed in the following nominal sizes 10, 12, 19 (3/8" - 3/4"). The proven design is suitable for use in industrial Hydraulic.

Features

- Flat Face
- Coupling made of stainless steel (AISI 316)
- ISO Interchange acc. to ISO 16028
- Integrated locking system preventing unintentional release of the coupling

Applications



Industrial Hydraulic

Top Features



Designed for secure connection

FH



Series FH • Stainless Steel

Material	Stainless Steel V4A (AISI 316)
Surface Finishing	-
Standard Seal Material(s)	FKM (Viton®), PTFE ²
Working Temperature	-25° C ... +200° C / -13° F ... +392° F
Valve Design	Flat Face
Connection	Push
Disconnection	Actuate Push Sleeve
Connect Under Pressure	not allowed
Application	Industrial Hydraulic
ISO Interchange	ISO 16028



²Alternative seal materials are available on request.

Technical Data

Series	BG	DN Zoll	DN metric	Q _{max}		Working Pressure		Bursting Pressure Connected		Female Body		Male Tip		Spillage	
				ISO 4397	l/min	US GPM	bar	PSI	bar	PSI	bar	PSI	bar	PSI	ml
FH-10	2	3/8"	10	45	11,89	250	3626	1300	18855	750	10878	1000	14504	0,015	.0005
FH-12	3	1/2"	12,5	90	23,78	250	3626	1300	18855	750	10878	1000	14504	0,02	.0007
FH-19	4	3/4"	19	180	47,55	250	3626	1300	18855	750	10878	1000	14504	0,032	.0011

The indicated pressure ratings only apply to the coupling itself and depend on the connection type.

Flow Characteristics

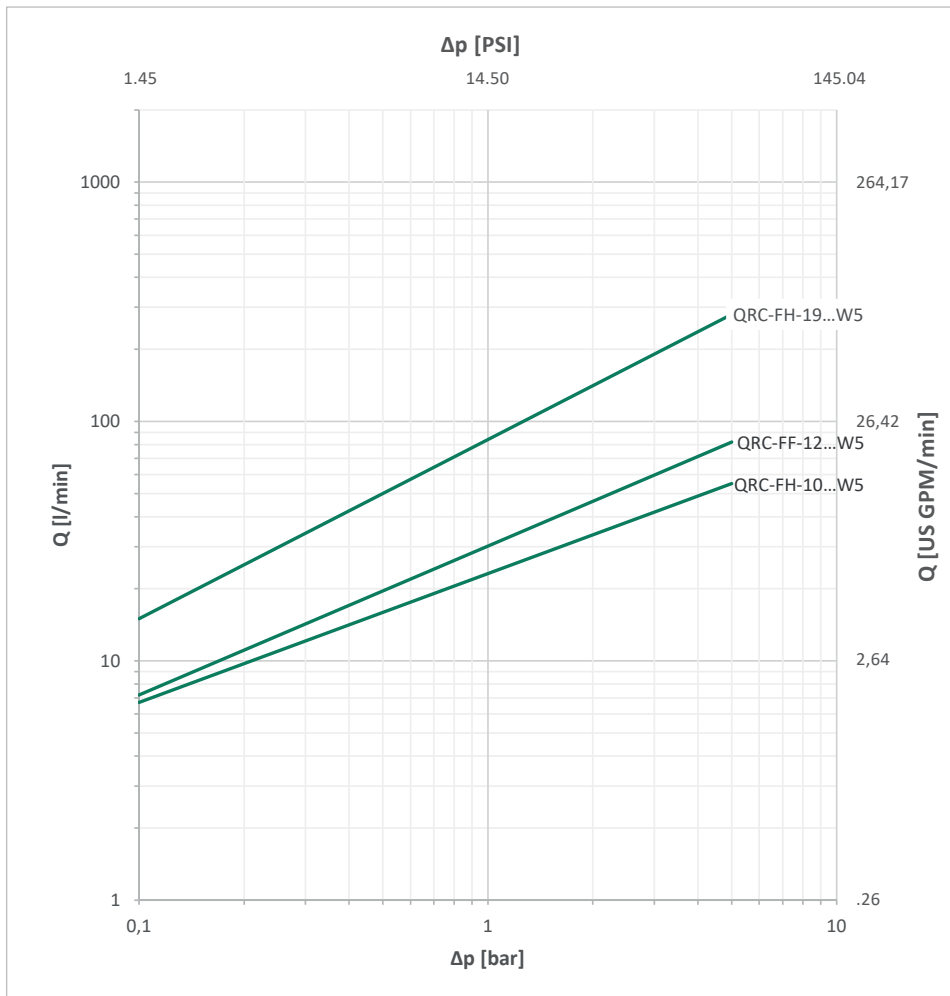

Please note: Unless otherwise stated, all flow characteristics have been determined with hydraulic oil with a kinematic viscosity of 28,8 - 35,2 mm²/s (28,8 - 35,2 cSt) and are only valid for components with non-reducing connections.



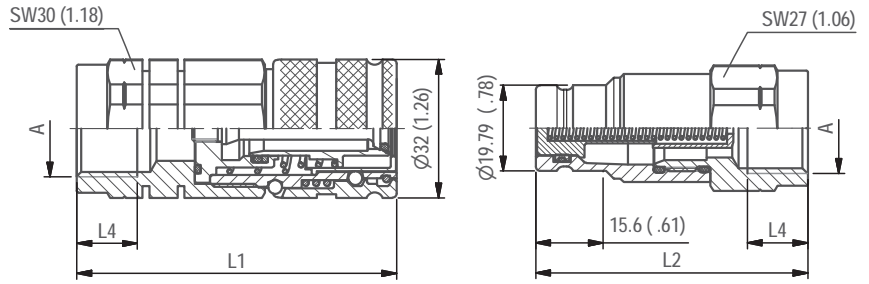

SW: Width across flats. All dimensions in mm (inch).

Series FH-10 • BG 2 • Nominal Size 10

Port A	Dimensions (mm/in)					Female Body Ordering Codes	Weight (kg/lbs) ca. per 100	Male Tip Ordering Codes	Weight (kg/lbs) ca. per 100
	ØD2	L1	L2	L3	L4				
Female Thread according to DIN 3852-2 - ISO 9974-1 - ANSI B 1.20.3									
	G 3/8"	68,9	57,8		12,5	QRC-FH-10-F-G06-VT-W5	30	QRC-FH-10-M-G06-VT-W5	15,80
		2.71	2.28		.49		66.14		34.83
	G 1/2"	74	62,9		14	QRC-FH-10-F-G08-VT-W5	30,40	QRC-FH-10-M-G08-VT-W5	15,50
		2.91	2.48		.55		67.02		34.17
	NPTF 1/2"	74	62,9			QRC-FH-10-F-NF08-VT-W5	30,80	QRC-FH-10-M-NF08-VT-W5	15,20
		2.91	2.48				67.90		33.51
Male Thread with 24° Conical Bore - Shape W according to DIN 3861									
	M18x1,5	12L	88,3	79,4	11	QRC-FH-10-F-12L-VT-W5	34,50	QRC-FH-10-M-12L-VT-W5	20,40
			3.48	3.13	.43				76.06

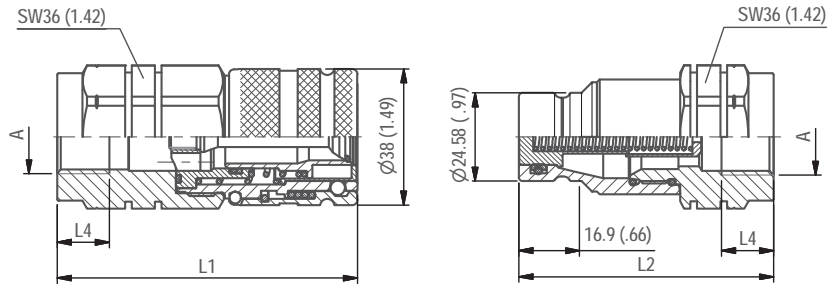

SW: Width across flats. All dimensions in mm (inch).

Series FH-12 • BG 3 • Nominal Size 12,5

Port A	Dimensions (mm/in)					Female Body Ordering Codes	Weight (kg/lbs) ca. per 100	Male Tip Ordering Codes	Weight (kg/lbs) ca. per 100
	ØD2	L1	L2	L3	L4				
Female Thread according to DIN 3852-2 - ISO 9974-1 - ANSI B 1.20.3									
	G 1/2"	84	71		14	QRC-FH-12-F-G08-VT-W5	52,50	QRC-FH-12-M-G08-VT-W5	32,60
		3.31	2.80		.55				115.74
	G 3/4"	84	71		16	QRC-FH-12-F-G12-VT-W5	49,10	QRC-FH-12-M-G12-VT-W5	29,50
		3.31	2.80		.63		108.25		65.04
	NPTF 1/2"	84	71			QRC-FH-12-F-NF08-VT-W5	52,80	QRC-FH-12-M-NF08-VT-W5	33
		3.31	2.80				116.40		72.75
Male Thread with 24° Conical Bore - Shape W according to DIN 3861									
	M18x1,5	12L	103,8	91,1	11	QRC-FH-12-F-12L-VT-W5	60,10	QRC-FH-12-M-12L-VT-W5	40,40
			4.09	3.59	.43				132.50
	M22x1,5	15L	104,8	92,1	12	QRC-FH-12-F-15L-VT-W5	60,60	QRC-FH-12-M-15L-VT-W5	40,90
			4.13	3.63	1,06				133.60

Note: The connection of the two halves of a coupling is achieved depending on the type. It is important to observe the positive engagement of plug-type couplings and the secure tightening of screw-type couplings to the limit stop of the thread. Forced or improper separation will result in malfunction of the coupling.



FH

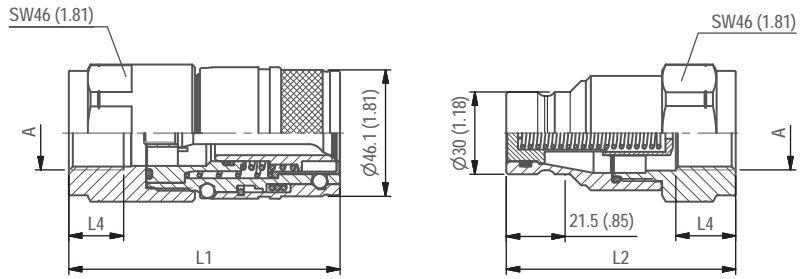

SW: Width across flats. All dimensions in mm (inch).

Series FH-19 • BG 4 • Nominal Size 19

Port A	Dimensions (mm/in)					Female Body Ordering Codes	Weight (kg/lbs) ca. per 100	Male Tip Ordering Codes	Weight (kg/lbs) ca. per 100
	ØD2	L1	L2	L3	L4				
Female Thread according to DIN 3852-2 - ISO 9974-1 - ANSI B 1.20.3									
	G 3/4"	99	84		16	QRC-FH-19-F-G12-VT-W5	102,90	QRC-FH-19-M-G12-VT-W5	57
		3.90	3.31		.63		226.86		125.66
	G 1"	99	84		18	QRC-FH-19-F-G16-VT-W5	97,20	QRC-FH-19-M-G16-VT-W5	51,10
3.90		3.31		.71	214.29		112.66		
NPTF 1"-11 1/2	99	84			QRC-FH-19-F-NF16-VT-W5	100,40	QRC-FH-19-M-NF16-VT-W5	54,30	
	3.90	3.31				221.34		119.71	
Male Thread with 24° Conical Bore - Shape W according to DIN 3861									
	M30x2	20S	130	114,8	16	QRC-FH-19-F-20S-VT-W5	120	QRC-FH-19-M-20S-VT-W5	74,10
			5.12	4.52	.63		264.55		163.36

Note: The connection of the two halves of a coupling is achieved depending on the type. It is important to observe the positive engagement of plug-type couplings and the secure tightening of screw-type couplings to the limit stop of the thread. Forced or improper separation will result in malfunction of the coupling.



Series FO • Stainless Steel
Product Description

Flat Face Push-to-Connect Couplings of the FO Series made of stainless steel AISI 316 from STAUFF are especially suitable for application with high corrosive environments and for the aggressive fluid mediums.

The FO Series consist of a male tip and a female body which are used for quick and easy connection (push) and disconnection of tubes, pipes and hoses by hand, i.e. without tools.

The Series was developed in the following nominal sizes 06, 10, 12, 19, 25 (1/4" - 1"). The proven design is suitable for use in the Offshore Industry.

Features

- Flat Face
- Coupling made of stainless steel (AISI 316)
- Integrated locking system preventing unintentional release of the coupling

Applications

Offshore Industry

Top Features

Designed for secure connection

FO

Series FO • Stainless Steel

Material	Stainless Steel V4A (AISI 316)
Surface Finishing	-
Standard Seal Material(s)	FKM (Viton®) ²
Working Temperature	-25° C ... +200° C / -13° F ... +392° F
Valve Design	Flat Face
Connection	Push
Disconnection	Actuate Push Sleeve
Connect Under Pressure	not allowed
Application	Offshore
ISO Interchange	-



FO

² Alternative seal materials are available on request.

Technical Data

Series	BG	DN Zoll Inch	DN metric ISO 4397	Q _{max}		Working Pressure		Bursting Pressure Connected		Female Body		Male Tip		Spillage	
				l/min	US GPM	bar	PSI	bar	PSI	bar	PSI	bar	PSI	ml	fl oz
FO-06	1	1/4"	6,3	20	5.28	350	5076	2100	30458	1400	20305	2000	29008	0,01	.0003
FO-10	2	3/8"	10	45	11.89	350	5076	2200	31908	1200	17405	1700	24656	0,02	.0007
FO-12	3	1/2"	12,5	60	15.85	350	5076	1800	26107	1200	17405	900	13053	0,03	.0010
FO-19	4	3/4"	19 (20)	150	39.63	350	5076	1450	21031	800	11603	1200	17405	0,06	.0020
FO-25	5	1"	25	240	63.40	350	5076	1200	17405	700	10153	900	13053	0,1	.0034

The indicated pressure ratings only apply to the coupling itself and depend on the connection type.

Flow Characteristics

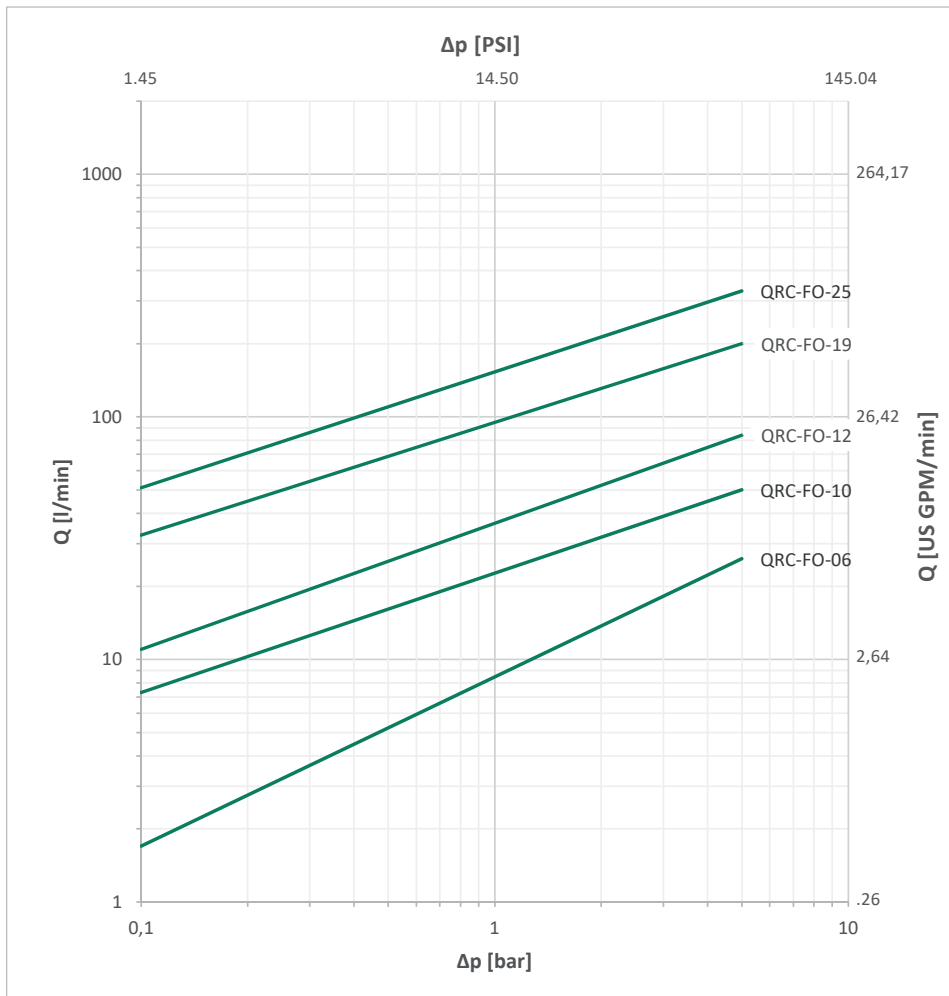

Please note: Unless otherwise stated, all flow characteristics have been determined with hydraulic oil with a kinematic viscosity of 28,8 - 35,2 mm²/s (28,8 - 35,2 cSt) and are only valid for components with non-reducing connections.



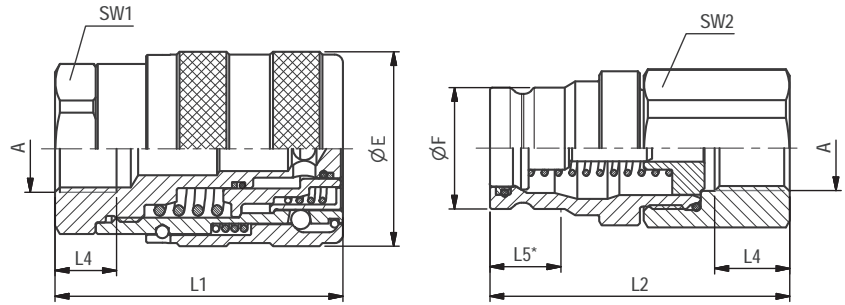

SW: Width across flats. All dimensions in mm (inch). Drawing similar Series FO-12.
* Insertion Male Tip

Series FO-06 ▪ BG 1 ▪ Nominal Size 6,3

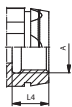
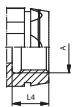
Port A	Dimensions (^{mm} / _{in})								Female Body Ordering Codes	Weight (^{kg} / _{lbs}) ca. per 100	Male Tip Ordering Codes	Weight (^{kg} / _{lbs}) ca. per 100
	ØE	ØF	L1	L2	L4 min	L5	SW1	SW2				
Female Thread according to DIN 3852 - ISO 1179-1 - ANSI B 1.20.3												
 G 1/4"	30	18	52	61,5	12	13,5	24	22	QRC-FO-06-F-G04-VT-W5	17,72	QRC-FO-06-M-G04-VT-W5	12,06
	1.18	.71	2.04	2.42	.47	.53	.94	.87		39.07		26.59
 NPTF 1/4" -18	30	18	52	61,5	12	13,5	24	22	QRC-FO-06-F-NF04-VT-W5	18,00	QRC-FO-06-M-NF04-VT-W5	12,30
	1.18	.71	2.04	2.42	.47	.53	.94	.87		39.68		27.12

Series FO-10 ▪ BG 2 ▪ Nominal Size 10

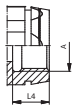
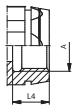
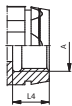
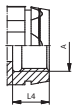
Port A	Dimensions (^{mm} / _{in})								Female Body Ordering Codes	Weight (^{kg} / _{lbs}) ca. per 100	Male Tip Ordering Codes	Weight (^{kg} / _{lbs}) ca. per 100
	ØE	ØF	L1	L2	L4 min	L5	SW1	SW2				
Female Thread according to DIN 3852 - ISO 1179-1 - ANSI B 1.20.3												
 G 3/8"	40	23,7	62	70	14	16,5	30	30	QRC-FO-10-F-G06-VT-W5	39	QRC-FO-10-M-G06-VT-W5	21,70
	1.57	.93	2.44	2.76	.47	.65	1.18	1.18		85.98		47.84
 NPTF 3/8" -18	40	23,7	62	70		16,5	30	30	QRC-FO-10-F-NF06-VT-W5	39	QRC-FO-10-M-NF06-VT-W5	22
	1.57	.93	2.44	2.76		.65	1.18	1.18		85.98		48.50
 G 1/2"	40	23,7	62	69,5	14	16,5	30	30	QRC-FO-10-F-G08-VT-W5	36,90	QRC-FO-10-M-G08-VT-W5	20,10
	1.57	.93	2.44	2.74	.55	.65	1.18	1.18		81.35		44.31
 NPTF 1/2" -14	40	23,7	62	73,5		16,5	30	30	QRC-FO-10-F-NF08-VT-W5	37,10	QRC-FO-10-M-NF08-VT-W5	21,60
	1.57	.93	2.44	2.89		.65	1.18	1.18		81.79		47.62

Series FO-12 ▪ BG 3 ▪ Nominal Size 12,5

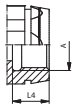
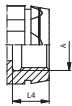
Port A	Dimensions (^{mm} / _{in})								Female Body Ordering Codes	Weight (^{kg} / _{lbs}) ca. per 100	Male Tip Ordering Codes	Weight (^{kg} / _{lbs}) ca. per 100
	ØE	ØF	L1	L2	L4 min	L5	SW1	SW2				
Female Thread according to DIN 3852 - ISO 1179-1 - ANSI B 1.20.3												
 G 1/2"	48	30	71	74	14	17,5	38	36	QRC-FO-12-F-G08-VT-W5	64,20	QRC-FO-12-M-G08-VT-W5	38,18
	1.89	1.18	2.80	2.91	.55	.69	1.49	1.42		141.54		84.17
 NPTF 1/2" -14	48	30	71	74		17,5	38	36	QRC-FO-12-F-NF08-VT-W5	63,90	QRC-FO-12-M-NF08-VT-W5	38,42
	1.89	1.18	2.80	2.91		.69	1.49	1.42		140.88		84.70

Series FO-19 ▪ BG 4 ▪ Nominal Size 19

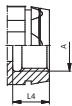
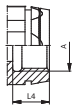
Port A	Dimensions (^{mm} / _{in})								Female Body Ordering Codes	Weight (^{kg} / _{lbs}) ca. per 100	Male Tip Ordering Codes	Weight (^{kg} / _{lbs}) ca. per 100
	ØE	ØF	L1	L2	L4 min	L5	SW1	SW2				
Female Thread according to DIN 3852 - ISO 1179-1 - ANSI B 1.20.3												
 G 3/4"	58	38,6	79	90	16	22	46	41	QRC-FO-19-F-G12-VT-W5	96,16	QRC-FO-19-M-G12-VT-W5	62
	2.28	1.52	3.11	3.54	.63	.87	1.81	1.61		212.00		123.46
 NPTF 3/4" -14	58	38,6	79	90		22	46	41	QRC-FO-19-F-NF12-VT-W5	96,00	QRC-FO-19-M-NF12-VT-W5	56,70
	2.28	1.52	3.11	3.54		.87	1.81	1.61		211.64		125.00

Note: The connection of the two halves of a coupling is achieved depending on the type. It is important to observe the positive engagement of plug-type couplings and the secure tightening of screw-type couplings to the limit stop of the thread. Forced or improper separation will result in malfunction of the coupling.



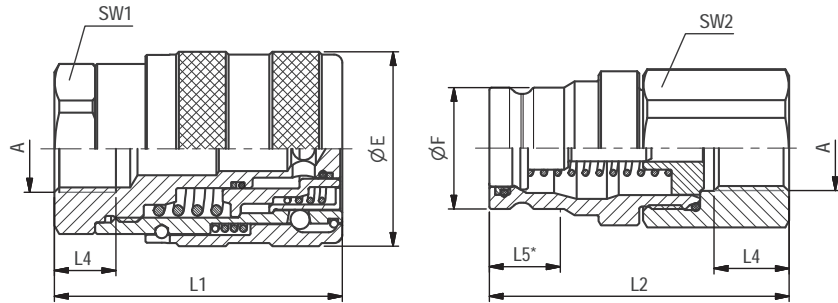

SW: Width across flats. All dimensions in mm (inch). Drawing similar Series FO-12.
* Insertion Male Tip

Series FO-25 • BG 5 • Nominal Size 25

Port A	Dimensions (mm/in)									Female Body	Weight (kg/lbs) ca. per 100	Male Tip	Weight (kg/lbs) ca. per 100
	ØE	ØF	L1	L2	L4 min	L5	SW1	SW2	Ordering Codes	Ordering Codes			
Female Thread according to DIN 3852 - ISO 1179-1 - ANSI B 1.20.3													
	G 1"	68	45	88	107	18	23	50	50	QRC-FO-25-F-G16-VT-W5	137	QRC-FO-25-M-G16-VT-W5	82,80
		2.68	1.77	3.46	4.21	.71	.90	1.97	1.97		302.03		182.54
	NPTF 1" -11 1/2	68	45	88	107	18	23	50	50	QRC-FO-25-F-NF16-VT-W5	138,50	QRC-FO-25-M-NF16-VT-W5	84
		2.68	1.77	3.46	4.21	.71	.90	1.97	1.97		305.34		185.19
	G 1 1/4"	68	45	88	107	18	23	50	50	QRC-FO-25-F-G20-VT-W5	127,50	QRC-FO-25-M-G20-VT-W5	86,80
		2.68	1.77	3.46	4.21	.71	.90	1.97	1.97		281.09		191.36
	NPTF 1 1/4" -11 1/2	68	45	88	107	18	23	50	50	QRC-FO-25-F-NF20-VT-W5	128,90	QRC-FO-25-M-NF20-VT-W5	880
		2.68	1.77	3.46	4.21	.71	.90	1.97	1.97		284.18		1936.00

Note: The connection of the two halves of a coupling is achieved depending on the type. It is important to observe the positive engagement of plug-type couplings and the secure tightening of screw-type couplings to the limit stop of the thread. Forced or improper separation will result in malfunction of the coupling.



Series HP • Carbon Steel
Product Description

Push/Pull Push-to-Connect Couplings with poppet Valve of the HP Series from STAUFF consist of a male tip and a female body which are used for quick and easy connection (push) and disconnection of tubes, pipes and hoses by hand, i.e. without tools.

The Series was developed according to ISO ISO 7241-1 A and ISO 5675 (for selected sizes) in the following nominal sizes 06, 10, 12, 19, (1/4" - 1") and can be connected under pressure with male tips of the HU series. The HU series from STAUFF consists of a male tip designed according to ISO 7241-1 A and is compatible with female bodies of this type.

Features

- poppet valve
- Zinc-Plating and Thick-Film-Passivation (Chrome III) and Zinc-Nickel for selected sizes
- Connection Under pressure allowed with STAUFF Female Bodys of the QRC-HP Series with Male Tips of the QRC-HU Series
- A reliable ball locking system keeps the two halves together
- can be installed as a breakaway coupling
- ISO Interchange acc. to ISO 7241-1 A and ISO 5675 (for selected sizes)

The sleeve of the female body can be installed in a bulkhead with retaining rings. In this way, the female body fulfils the function of a breakaway coupling. Should a male tip be torn away from a female body installed in this way, the system is decoupled and the valves close automatically, thus preventing damage to the hose and possible loss of oil.

The proven design is suitable for use in agricultural and forestry machinery and hydraulic attachments.

HP/HU
Applications

Agricultural and Forestry Machinery
Top Features

Suitable for panel mounting

Designed for secure connection

Series HP ▪ Carbon Steel

Material	Carbon Steel
Surface Finishing	Zinc-Nickel ¹ , Zinc-Plating and Thick-Film-Passivation (Chrome III)
Standard Seal Material(s)	NBR (Buna-N®), PTFE ²
Working Temperature	-25° C ... +100° C / -13° F ... +212° F
Valve Design	Poppet Valve
Connection	Push (When mounting the Sleeve in Bulkhead), Push and actuate Push-Pull Sleeve
Disconnection	Pull (When mounting the Sleeve in Bulkhead), Actuate Push-Pull Sleeve
Connect Under Pressure	not allowed, (Male Tip Series HU up to the max. Working Pressure allowed)
Application	Agricultural and Forestry Machinery
ISO Interchange	ISO 7241-1 A and ISO 5675 (for selected sizes).



HP/HU

¹ Only Nominal Size 12,5
² Alternative seal materials are available on request.

Technical Data

Series	BG	DN Zoll	DN metric ISO 4397	Q _{max}		Working Pressure		Bursting Pressure Connected		Female Body		Male Tip		Spillage	
				l/min	US GPM	bar	PSI	bar	PSI	bar	PSI	bar	PSI	ml	fl oz
HPA-06	1	1/4"	6,3	20	5.28	250	3626	1000	14504	1000	14504	1000	14504	0,8	.0271
HP(A)-10	2	3/8"	10	35	9.25	250	3626	1000	14504	1000	14504	1000	14504	1,2	.0406
HP-12	3	1/2"	12,5	100	26.42	250	3626	1000	14504	1000	14504	1000	14504	1,7	.0575
HP-19	4	3/4"	19 (20)	120	31.70	250	3626	900	13053	1000	14504	1000	14504	8	.2705
HP-25	6	1"	25	160	42.27	250	3626	800	11603	1000	14504	800	11603	12	.4058
HU-12	3	1/2"	12	90	23.78	250	3626	1100	15954	1500	21756	1000	14504	2,7	.0913

The indicated pressure ratings only apply to the coupling itself and depend on the connection type.

Flow Characteristics

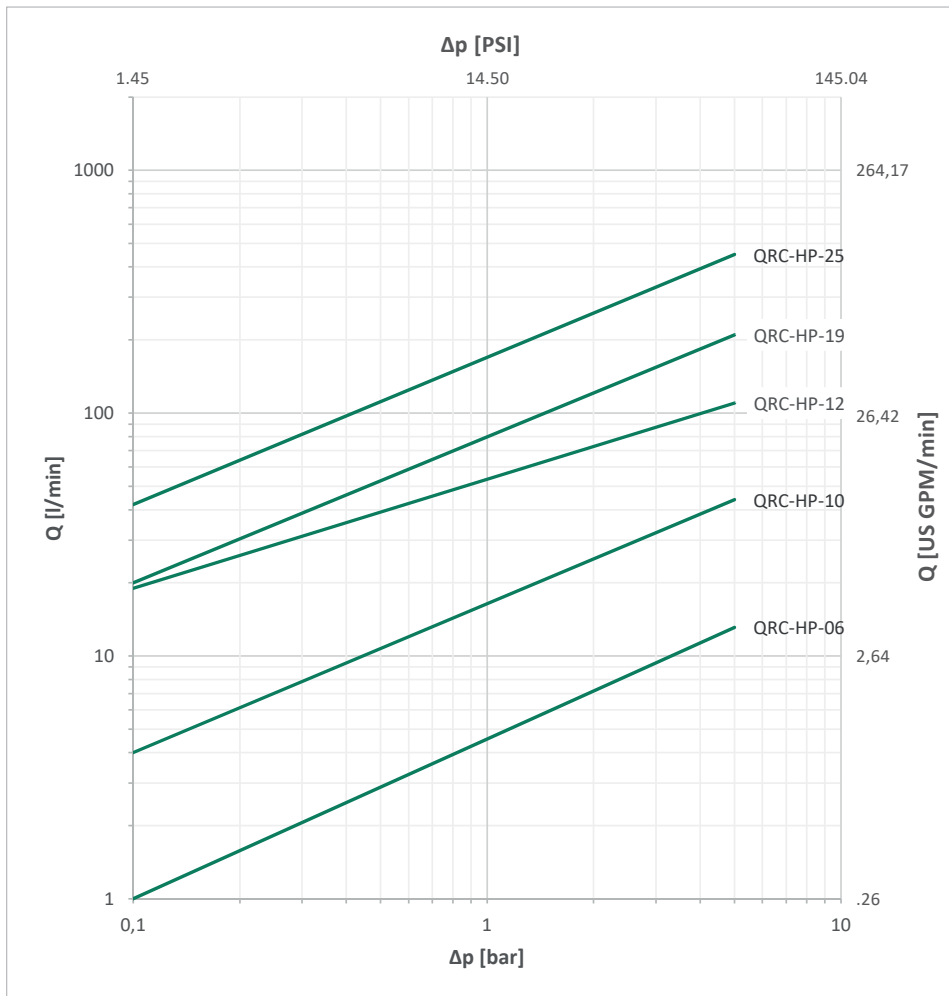

Please note: Unless otherwise stated, all flow characteristics have been determined with hydraulic oil with a kinematic viscosity of 28,8 - 35,2 mm²/s (28,8 - 35,2 cSt) and are only valid for components with non-reducing connections.



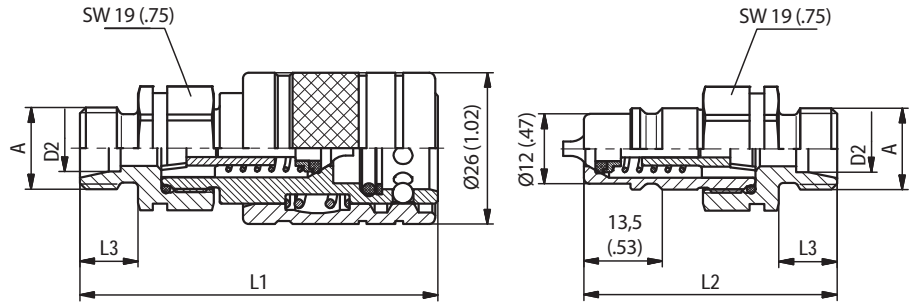

SW: Width across flats. All dimensions in mm (inch).

Series HPA-06 • BG 1 • Nominal Size 6,3
HP/HU

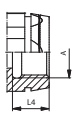
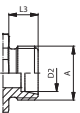
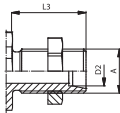
Port A	Dimensions (^{mm} / _{in})					Female Body Ordering Codes	Weight (^{kg} / _{lbs}) ca. per 100	Male Tip Ordering Codes	Weight (^{kg} / _{lbs}) ca. per 100
	ØD2	L1	L2	L3	L4				
Female Thread according to DIN 3852-2-A - ANSI B 1.20.3									
	G1/4"	64	44	13		QRC-HPA-06-F-G04-BT-W66	14,60 32.19	QRC-HPA-06-M-G04-B-W66	5,20 11.46
	NPTF 1/4" -18	64	44			QRC-HPA-06-F-NF04-BT-W66	15 33.07	QRC-HPA-06-M-NF04-B-W66	5,20 11.46
Male Thread with 24° Conical Bore - Shape W according to DIN 3861									
	M14x1,5	8L	62	42	10	QRC-HPA-06-F-08L-BT-W66	13,40	QRC-HPA-06-M-08L-B-W66	4
			2.44	1.65	.39				29.54
Male Thread with 24° Conical Bore - Bulkhead - Shape W according to DIN 3861									
	M14x1,5	8L	77	59	25	QRC-HPA-06-F-08LB-BT-W66	15,40	QRC-HPA-06-M-08LB-B-W66	6,20
			3.01	2.30	.98				33.95

Note: The connection of the two halves of a coupling is achieved depending on the type. It is important to observe the positive engagement of plug-type couplings and the secure tightening of screw-type couplings to the limit stop of the thread. Forced or improper separation will result in malfunction of the coupling.



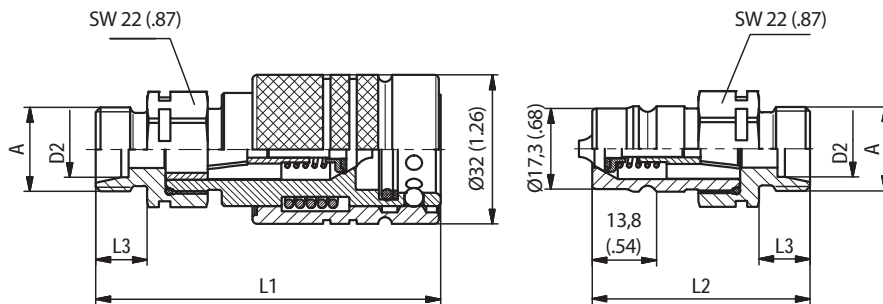

SW: Width across flats. All dimensions in mm (inch).

Dimensions acc. to ISO 7241-1, Series A, Size 10.

HP/HU

Series HP-10 • BG 2 • Nominal Size 10

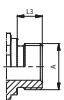
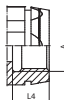
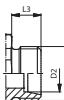
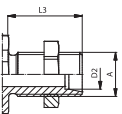
Port A	Dimensions (^{mm} / _{in})					Female Body Ordering Codes	Weight (^{kg} / _{lbs}) ca. per 100	Male Tip Ordering Codes	Weight (^{kg} / _{lbs}) ca. per 100
	ØD2	L1	L2	L3	L4				
Male Thread according to ISO 1179-4-B									
	G3/8"		77	51	12	QRC-HP-10-F-B06-BT-W66	2,20	QRC-HP-10-M-B06-B-W66	7,80
			3.03	2.01	.47		4.85		17.2
Female Thread according to DIN 3852-2-A - ISO 9974-1 - ANSI B 1.20.3									
	G1/4"		76	49	13	QRC-HP-10-F-G04-BT-W66	19,50	QRC-HP-10-M-G04-B-W66	88
			2.99	1.93	.51		42.99		193.60
	G3/8"		76	49	13	QRC-HP-10-F-G06-BT-W66	18,80	QRC-HP-10-M-G06-B-W66	80
			2.99	1.93	.51		41.45		176.00
M16x1,5		76	49	13	QRC-HP-10-F-M16-BT-W66	18,80	QRC-HP-10-M-M16-B-W66	81	
NPTF 3/8"-18		2.99	1.93	.51	QRC-HP-10-F-NF06-BT-W66	41.45	QRC-HP-10-M-NF06-B-W66	178.20	
Male Thread with 24° Conical Bore - Shape W according to DIN 3861									
	M14x1,5	8L	73	46	10	QRC-HP-10-F-08L-BT-W66	21	QRC-HP-10-M-08L-B-W66	4,20
			2.87	1.81	.39		46.30		9.26
	M16x1,5	10L	74	47	11	QRC-HP-10-F-10L-BT-W66	21	QRC-HP-10-M-10L-B-W66	6,50
			2.91	1.85	.43		46.30		14.33
	M18x1,5	12L	74	47	11	QRC-HP-10-F-12L-BT-W66	21,50	QRC-HP-10-M-12L-B-W66	7,30
			2.91	1.84	.43		47.40		16,09
M16x1,5	8S	75	48	12	QRC-HP-10-F-08S-BT-W66	21,20	QRC-HP-10-M-08S-B-W66	7,10	
		2.95	1.89	.47		46.74		15.65	
M18x1,5	10S	75	48	12	QRC-HP-10-F-10S-BT-W66	21,60	QRC-HP-10-M-10S-B-W66	7,20	
M20x1,5	12S	2.95	1.89	.47	QRC-HP-10-F-12S-BT-W66	47.62	QRC-HP-10-M-12S-B-W66	15.87	
Male Thread with 24° Conical Bore - Bulkhead - Shape W according to DIN 3861									
	M14x1,5	8L	88	61	25	QRC-HP-10-F-08LB-BT-W66	22,80	QRC-HP-10-M-08LB-B-W66	8,40
			3.46	2.39	.98		50.27		18.51
	M16x1,5	10L	89	62	26	QRC-HP-10-F-10LB-BT-W66	23,40	QRC-HP-10-M-10LB-B-W66	9
			3.50	2.43	1.02		51.59		19.84
	M18x1,5	12L	89	62	26	QRC-HP-10-F-12LB-BT-W66	23,50	QRC-HP-10-M-12LB-B-W66	9,40
			3.50	2.43	1.02		51.81		20.72
M16x1,5	08S	90	63	27	QRC-HP-10-F-08SB-BT-W66 *	23	QRC-HP-10-M-08SB-B-W66 *	10	
		3.54	2.47	1.06		50.71		22.05	
M20x1,5	12S	90	63	27	QRC-HP-10-F-12SB-BT-W66 *	22	QRC-HP-10-M-12SB-B-W66 *	7,40	
		3.54	2.47	1.06		48.50		16.31	

* Available on request.

Note: The connection of the two halves of a coupling is achieved depending on the type. It is important to observe the positive engagement of plug-type couplings and the secure tightening of screw-type couplings to the limit stop of the thread. Forced or improper separation will result in malfunction of the coupling.



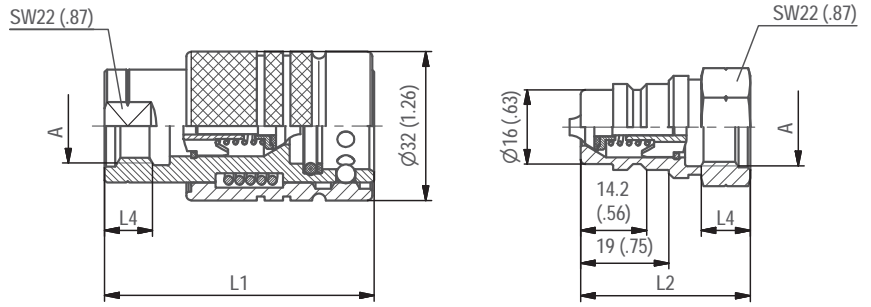

SW: Width across flats. All dimensions in mm (inch).

Series HPA-10 ▪ BG 2 ▪ Nominal Size 10
HP/HU

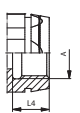
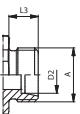
Port A	Dimensions (mm/in)					Female Body Ordering Codes	Weight (^{kg} /lbs) ca. per 100	Male Tip Ordering Codes	Weight (^{kg} /lbs) ca. per 100
	ØD2	L1	L2	L3	L4				
Female Thread according to DIN 3852-2-A - ANSI B 1.20.3									
	G3/8"	58	37	14		QRC-HPA-10-F-G06-BT-W66	18,80	QRC-HPA-10-M-G06-B-W66	5,10
		2.28	1.46	.55			41.45		11.24
Male Thread with 24° Conical Bore - Bulkhead - Shape W according to DIN 3861									
	M16x1,5	58	37	14		QRC-HPA-10-F-10L-BT-W66	22,60	QRC-HPA-10-M-10L-B-W66	8,80
		2.28	1.44	.55			49.82		19.40

Note: The connection of the two halves of a coupling is achieved depending on the type. It is important to observe the positive engagement of plug-type couplings and the secure tightening of screw-type couplings to the limit stop of the thread. Forced or improper separation will result in malfunction of the coupling.



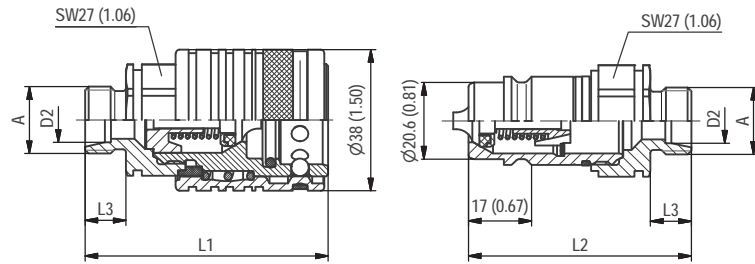

SW: Width across flats. All dimensions in mm (inch).

Dimensions acc. to ISO 7241-1, Series A, Size 12,5 and ISO 5675.

HP/HU

Series HP-12 ▪ BG 3 ▪ Nominal Size 12,5

Port A	Dimensions (^{mm} / _{in})					Female Body Ordering Codes	Weight (^{kg} / _{lbs}) ca. per 100	Male Tip Ordering Codes	Weight (^{kg} / _{lbs}) ca. per 100
	ØD2	L1	L2	L3	L4				
Male Thread according to ISO 1179-4-B - ISO 9974-3									
	G 3/8"	71 2.80	61 2.40	12 .47		QRC-HP-12-F-B06-B-W3	29 63.93	QRC-HP-12-M-B06-B-W3	11,90 26.24
	G 1/2"	71 2.80	61 2.40	12 .47		QRC-HP-12-F-B08-B-W3	29,60 65.26	QRC-HP-12-M-B08-B-W3	12,30 27.12
	M22x1,5	71 2.80	61 2.40	12 .47		QRC-HP-12-F-M22M-B-W3	30 66.14	QRC-HP-12-M-M22M-B-W3	12,90 28.44
Female Thread according to DIN 3852-2-A - ISO 6149-1 - ISO 9974-1 - ANSI B 1.20.3 - SAE J1926-1 - ISO 11926-1									
	G3/8"	68 2.68	60 2.36		15 .59	QRC-HP-12-F-G06-B-W3	33,10 72.97	QRC-HP-12-M-G06-B-W3	15,30 33.73
		G 1/2"	70 2.76	48 1.89		17 .67	QRC-HP-12-F-G08-B-W3	28 61.73	QRC-HP-12-M-G08-B-W3
	M16x1,5		67 2.65	62 2.43		15 .59	QRC-HP-12-F-M160R-B-W3	31,80 70.11	QRC-HP-12-M-M160R-B-W3
		M18x1,5	68 2.68	60 2.36		15 .59	QRC-HP-12-F-M180R-B-W3	31,80 70.11	QRC-HP-12-M-M180R-B-W3
	M22x1,5		70 2.76	48 1.89		17 .67	QRC-HP-12-F-M22-B-W3	28,40 62.61	QRC-HP-12-M-M220R-B-W3
		NPTF 1/2"-14	70 2.76	48 1.89			QRC-HP-12-F-NF08-B-W3	29,40 64.82	QRC-HP-12-M-NF08-B-W3
	UNF 3/4"-16		77 3.03	48 1.89		14 .55	QRC-HP-12-F-U08-B-W3	27,80 61.29	QRC-HP-12-M-U08-B-W3

Note: The connection of the two halves of a coupling is achieved depending on the type. It is important to observe the positive engagement of plug-type couplings and the secure tightening of screw-type couplings to the limit stop of the thread. Forced or improper separation will result in malfunction of the coupling.



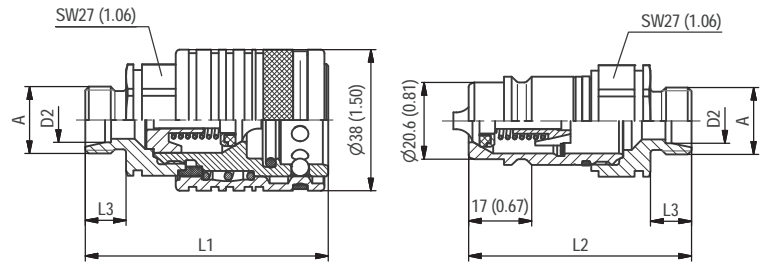

SW: Width across flats. All dimensions in mm (inch).

Dimensions acc. to ISO 7241-1, Series A, Size 12,5 and ISO 5675.

Series HP-12 ▪ BG 3 ▪ Nominal Size 12,5
HP/HU

Port A	Dimensions (mm/in)					Female Body	Weight (^{kg} /lbs) ca. per 100	Male Tip	Weight (^{kg} /lbs) ca. per 100
	ØD2	L1	L2	L3	L4	Ordering Codes		Ordering Codes	
Male Thread with 24° Conical Bore - Shape W according to DIN 3861									
	M14x1,5	8L	64 2.53	58 2.30	10 .39	QRC-HP-12-F-08L-B-W3	26,20 57.76	QRC-HP-12-M-08L-B-W3	10,70 23.59
	M16x1,5	10L	65 2.57	60 2.35	11 .43	QRC-HP-12-F-10L-B-W3	25,70 56.66	QRC-HP-12-M-10L-B-W3	10,90 24.03
	M18x1,5	12L	65 2.57	60 2.35	11 .43	QRC-HP-12-F-12L-B-W3	25,70 56.66	QRC-HP-12-M-12L-B-W3	10,90 24.03
	M22x1,5	15L	66 2.61	61 2.39	12 .47	QRC-HP-12-F-15L-B-W3	26,50 58.42	QRC-HP-12-M-15L-B-W3	11,70 25.79
	M26x1,5	18L	66 2.61	61 2.39	12 .47	QRC-HP-12-F-18L-B-W3	27,30 60.19	QRC-HP-12-M-18L-B-W3	11,90 26.24
	M18x1,5	10S	66 2.61	61 2.39	12 .47	QRC-HP-12-F-10S-B-W3	26,50 58.42	QRC-HP-12-M-10S-B-W3	11,50 25.35
	M20x1,5	12S	66 2.61	61 2.39	12 .47	QRC-HP-12-F-12S-B-W3	26,70 58.86	QRC-HP-12-M-12S-B-W3	11,70 25.79
	M22x1,5	14S	68 2.69	63 2.47	14 .55	QRC-HP-12-F-14S-B-W3	27,30 60.19	QRC-HP-12-M-14S-B-W3	12,30 27.12
	M24x1,5	16S	68 2.69	63 2.47	14 .55	QRC-HP-12-F-16S-B-W3	27,50 60.63	QRC-HP-12-M-16S-B-W3	12,50 27.56
	Male Thread with 24° Conical Bore - Bulkhead - Shape W according to DIN 3861								
	M14x1,5	08L	80 3.16	75 2.94	26 1.02	QRC-HP-12-F-08LB-B-W3	28,20 62.17	QRC-HP-12-M-08LB-B-W3	12,90 28.44
	M16x1,5	10L	80 3.16	75 2.94	26 1.02	QRC-HP-12-F-10LB-B-W3	28,80 63.49	QRC-HP-12-M-10LB-B-W3	13,50 29.76
	M18x1,5	12L	84 3.31	79 3.10	30 1.18	QRC-HP-12-F-12LB-B-W3	29,10 64.15	QRC-HP-12-M-12LB-B-W3	14,30 31.53
	M22x1,5	15L	81 3.19	76 2.98	27 1.06	QRC-HP-12-F-15LB-B-W3	30,70 67.68	QRC-HP-12-M-15LB-B-W3	15,90 35.05
	M26x1,5	18L	81 3.20	76 2.98	27 1.06	QRC-HP-12-F-18LB-B-W3	34,10 75.18	QRC-HP-12-M-18LB-B-W3	19,30 42.55
	M18x1,5	10S	80 3.16	75 2.94	26 1.02	QRC-HP-12-F-10SB-B-W3	29,70 65.48	QRC-HP-12-M-10SB-B-W3	14,70 32.41
	M20x1,5	12S	81 3.20	76 2.98	27 1.06	QRC-HP-12-F-12SB-B-W3	30,50 67.24	QRC-HP-12-M-12SB-B-W3	15,50 34.17
	M22x1,5	14S	83 3.28	78 3.06	29 1.14	QRC-HP-12-F-14SB-B-W3	31,90 70.33	QRC-HP-12-M-14SB-B-W3	17,10 37.70
	M24x1,5	16S	83 3.28	78 3.06	29 1.14	QRC-HP-12-F-16SB-B-W3	33,30 73.41	QRC-HP-12-M-16SB-B-W3	18,30 40.34

Note: The connection of the two halves of a coupling is achieved depending on the type. It is important to observe the positive engagement of plug-type couplings and the secure tightening of screw-type couplings to the limit stop of the thread. Forced or improper separation will result in malfunction of the coupling.



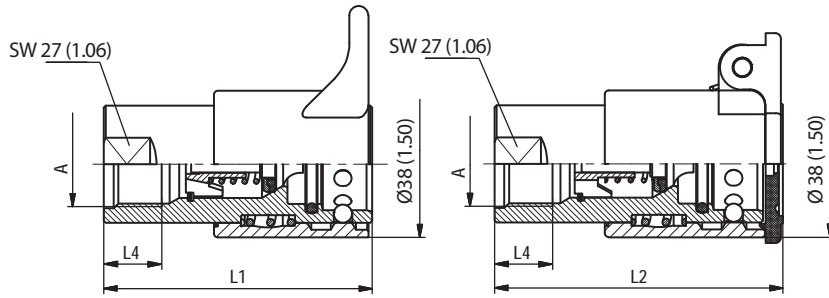





SW: Width across flats. All dimensions in mm (inch).

Dimensions acc. to ISO 7241-1, Series A, Size 12,5 and ISO 5675.

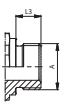
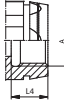
HP/HU

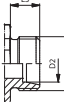
Series ZP-12 ▪ BG 3 ▪ Nominal Size 12,5

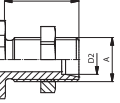
Port A	Dimensions (mm/in)					Female Body Ordering Codes	Weight (^{kg} /lbs) ca. per 100	Male Tip Ordering Codes	Weight (^{kg} /lbs) ca. per 100	
	ØD2	L1	L2	L3	L4					
Male Thread according to DIN 3852										
 G 1/2"		74		12		QRC-ZP-12-F-B08-B-W3	31,40			
		2.92		.47			69.23			
Female Thread according to DIN 3852-2 - ISO 9974-1										
 G1/2"		70			17	QRC-ZP-12-F-G08-B-W3	31,40			
		2.76			.67		69.23			
 M22x1,5		70	75		17	QRC-ZP-12-F-M22-B-W3	31	QRC-ZP-12-FF-M22/L-B-W3-SW	30,50	
		2.76	2.95		.67		68.34		67.24	
Male Thread with 24° Conical Bore - Shape W according to DIN 3861										
 M18x1,5	12L	70			11	QRC-ZP-12-F-12L-B-W3	30,10			
		2.76			.43		66.36			
 M22x1,5	15L	71			12	QRC-ZP-12-F-15L-B-W3	30,90			
		2.80			.47		68.12			
Male Thread with 24° Conical Bore - Bulkhead - Shape W according to DIN 3861										
 M18x1,5	12L	89	93	30		QRC-ZP-12-F-12LB-B-W3	33,50	QRC-ZP-12-FF-12LB/S-B-W3-SW	36,20	
			3.51	3.67	1.18				73.85	79.81
	M22x1,5	15L	86	90	27		QRC-ZP-12-F-15LB-B-W3	35,10	QRC-ZP-12-FF-15LB/S-B-W3-SW	38,90
				3.39	3.55	1.06				77.38
M20x1,5	12S		90	27				QRC-ZP-12-FF-12SB/L-B-W3-SW	39,30	
				3.55	1.06					86.64
M24x1,5	16S		88,6	29				QRC-ZP-12-FF-16SB/L-B-W3-SW	41,50	
			3.49	1.14					91.49	

Note: The connection of the two halves of a coupling is achieved depending on the type. It is important to observe the positive engagement of plug-type couplings and the secure tightening of screw-type couplings to the limit stop of the thread. Forced or improper separation will result in malfunction of the coupling.



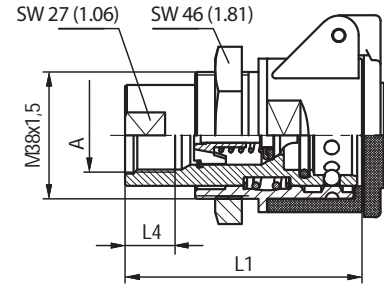
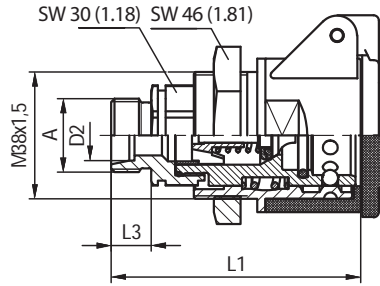

SW: Width across flats. All dimensions in mm (inch).

Dimensions acc. to ISO 7241-1, Series A, Size 12,5 and ISO 5675.

Series AP-12 • BG 3 • Nominal Size 12,5
HP/HU

Port A	Dimensions (mm/in)					Female Body Ordering Codes	Weight (kg/lbs) ca. per 100
	ØD2	L1	L2	L3	L4		
Innengewinde entsprechend ISO 9974-1							
	M22x1,5		75		15	QRC-AP-12-FF-M22M30-B-W3-RD/BK	38,10
			2.95		.59		84
Male Thread with 24° Conical Bore - Shape W according to DIN 3861							
	M22x1,5	15L	72		12	QRC-AP-12-FF-15L-B-W3-RD/BK	39
			2.84		.47		85.98

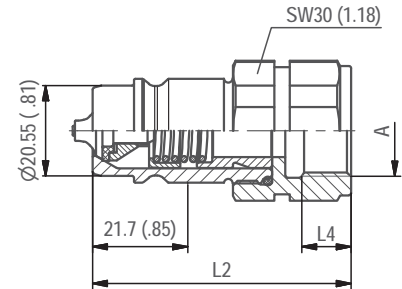

SW: Width across flats. All dimensions in mm (inch).

 Male Tip Connect Under Pressure - use our HP-12 Female side.
 Dimensions acc. to ISO 7241-1, Series A

Series HU-12 • BG 3 • Nominal Size 12,5 • Connect Under Pressure

Port A	Dimensions (mm/in)					Male Tip Ordering Codes	Weight (kg/lbs) ca. per 100
	ØD2	L1	L2	L3	L4		
Female Thread according to DIN 3852-2-A - ANSI B 1.20.3							
	G3/8"		46		12	QRC-HU-12-M-G06-B-W3	16,60
			1.81		.47		36.60
	NPTF 3/8" -18		46			QRC-HU-12-M-NF06-B-W3	19,20
			1.81				42.33
	G1/2"		46		14	QRC-HU-12-M-G08-B-W3	16,20
			1.81		.55		35.71
	NPTF 1/2" -14		46			QRC-HU-12-M-NF08-B-W3	17,60
			1.81				38.80

Note: The connection of the two halves of a coupling is achieved depending on the type. It is important to observe the positive engagement of plug-type couplings and the secure tightening of screw-type couplings to the limit stop of the thread. Forced or improper separation will result in malfunction of the coupling.



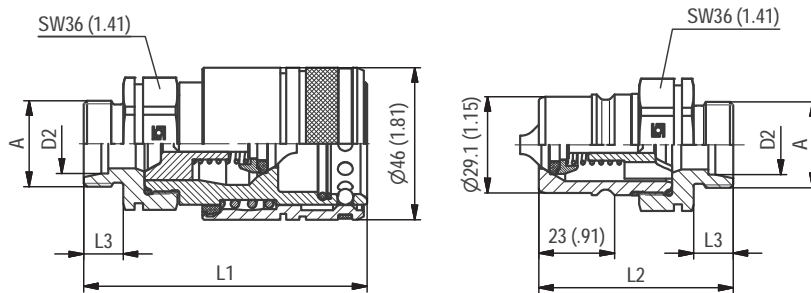

SW: Width across flats. All dimensions in mm (inch).

Dimensions acc. to ISO 7241-1, Series A, Size 19 and ISO 5675.

HP/HU

Series HP-19 • BG 4 • Nominal Size 19

Port A	Dimensions (mm/in)					Female Body Ordering Codes	Weight (^{kg} /lbs) ca. per 100	Male Tip Ordering Codes	Weight (^{kg} /lbs) ca. per 100
	ØD2	L1	L2	L3	L4				
Female Thread according to DIN 3852-2 - ISO 9974-1									
	G3/4"	92	65		19	QRC-HP-19-F-G12-BT-W66	60,50 133.38	QRC-HP-19-M-G12-B-W66	31,50 69.45
	M22x1,5	92	65		19	QRC-HP-19-F-M22-BT-W66	62,80 138.45	QRC-HP-19-M-M22-B-W66	31,30 69
	NPTF 3/4"-14	92	65			QRC-HP-19-F-NF12-BT-W66	62,80 138.45	QRC-HP-19-M-NF12-B-W66	31,30 69
Male Thread with 24° Conical Bore - Shape W according to DIN 3861									
	M18x1,5	12L	85	58	11	QRC-HP-19-F-12L-BT-W66	54,40 119.93	QRC-HP-19-M-12L-B-W66	22,70 50.04
		15L	86	59	12	QRC-HP-19-F-15L-BT-W66	54,60 120.37	QRC-HP-19-M-15L-B-W66	23,20 51.15
	M22x1,5	18L	86	59	12	QRC-HP-19-F-18L-BT-W66	55,50 122.36	QRC-HP-19-M-18L-B-W66	23,80 52.47
		22L	88	61	14	QRC-HP-19-F-22L-BT-W66	56,90 125.44	QRC-HP-19-M-22L-B-W66	24,80 54.67
	M24x1,5	16S	88	61	14	QRC-HP-19-F-16S-BT-W66	56 123.46	QRC-HP-19-M-16S-B-W66	24,20 53.35
		20S	90	63	16	QRC-HP-19-F-20S-BT-W66	57,20 126.10	QRC-HP-19-M-20S-B-W66	25,20 55.56
	Male Thread with 24° Conical Bore - Bulkhead - Shape W according to DIN 3861								
	M18x1,5	12L	100	73	26	QRC-HP-19-F-12LB-BT-W66	57,40 126.55	QRC-HP-19-M-12LB-B-W66	27,60 60.85
		15L	101	74	27	QRC-HP-19-F-15LB-BT-W66	59 130.07	QRC-HP-19-M-15LB-B-W66	27,40 60.41
	M22x1,5	18L	101	74	27	QRC-HP-19-F-18LB-BT-W66	62,70 138.23	QRC-HP-19-M-18LB-B-W66	31 68.34
		22L	110	83	36	QRC-HP-19-F-22LB-BT-W66	67,50 148.81	QRC-HP-19-M-22LB-B-W66	35,50 78.26
	M24x1,5	16S	103	76	29	QRC-HP-19-F-16SB-BT-W66	61,40 135.36	QRC-HP-19-M-16SB-B-W66	29,80 65.70
		20S	110	83	36	QRC-HP-19-F-20SB-BT-W66	68,50 151.02	QRC-HP-19-M-20SB-B-W66	36,20 79.81

Note: The connection of the two halves of a coupling is achieved depending on the type. It is important to observe the positive engagement of plug-type couplings and the secure tightening of screw-type couplings to the limit stop of the thread. Forced or improper separation will result in malfunction of the coupling.



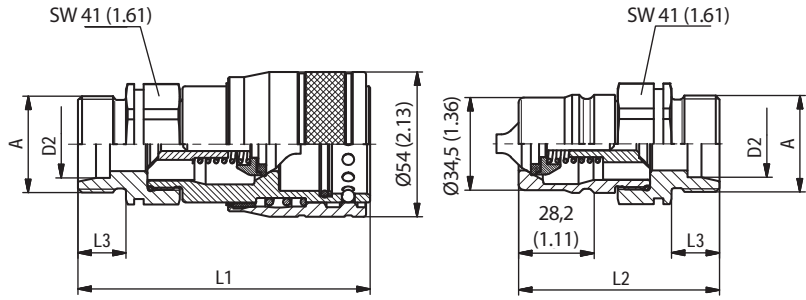

SW: Width across flats. All dimensions in mm (inch).

Dimensions acc. to ISO 7241-1, Series A, Size 25.

Series HP-25 ▪ BG 6 ▪ Nominal Size 25
HP/HU

Port A	Dimensions (^{mm} / _{in})				Female Body		Weight (^{kg} / _{lbs}) ca. per 100	Male Tip		Weight (^{kg} / _{lbs}) ca. per 100
	ØD2	L1	L2	L3	L4	Ordering Codes		Ordering Codes		
Female Thread according to DIN 3852-2-A - ANSI B 1.20.3										
	G3/4"	104	72		19	QRC-HP-25-F-G12-BT-W66	87,60	QRC-HP-25-M-G12-B-W66	40,90	
		4.09	2.83		.75		193.12		90.17	
	G1"	104	72		19	QRC-HP-25-F-G16-BT-W66	83,40	QRC-HP-25-M-G16-B-W66	36,30	
		4.09	2.83		.75		183.87		80.03	
	NPTF 1"-11 1/2	104	72			QRC-HP-25-F-NF16-BT-W66	83,40	QRC-HP-25-M-NF16-B-W66	36,30	
		4.09	2.83				183.87		80.03	
Male Thread with 24° Conical Bore - Shape W according to DIN 3861										
	M22x1,5	15L	103	69	12	QRC-HP-25-F-15L-BT-W66	79,70	QRC-HP-25-M-15L-B-W66 *	34,60	
			4.06	2.72	.47			175.71		76.28
	M26x1,5	18L	103	69	12	QRC-HP-25-F-18L-BT-W66	81,30	QRC-HP-25-M-18L-B-W66	34,80	
			4.06	2.72	.47			179.24		76.72
	M30x2	22L	105	71	14	QRC-HP-25-F-22L-BT-W66	81,70	QRC-HP-25-M-22L-B-W66	35,50	
			4.13	2.80	.55			180.12		78.26
	M36x2	28L	105	71	14	QRC-HP-25-F-28L-BT-W66	81,90	QRC-HP-25-M-28L-B-W66	36	
			4.13	2.80	.55			180.56		79.37
	M45x2	35L	107	73	16	QRC-HP-25-F-35L-BT-W66 *	89,60	QRC-HP-25-M-35L-B-W66 *	44,50	
			4.21	2.87	.63			197.53		98.11
M30x2	20S	107	73	16	QRC-HP-25-F-20S-BT-W66	82,80	QRC-HP-25-M-20S-B-W66	36,10		
		4.21	2.87	.63			182.54		79.59	
M36x2	25S	109	75	18	QRC-HP-25-F-25S-BT-W66	85	QRC-HP-25-M-25S-B-W66	38		
		4.29	2.95	.71			187.39		83.78	
M42x2	30S	111	77	20	QRC-HP-25-F-30S-BT-W66	82	QRC-HP-25-M-30S-B-W66	44		
		4.37	3.03	.79			180.78		97	
Male Thread with 24° Conical Bore - Bulkhead - Shape W according to DIN 3861										
	M22x1,5	15L	118	84	27	QRC-HP-25-F-15LB-BT-W66	82,90	QRC-HP-25-M-15LB-B-W66 *	37,80	
			4.65	3.31	1.06			182.76		83.33
	M26x1,5	18L	123	89	32	QRC-HP-25-F-18LB-BT-W66	85	QRC-HP-25-M-18LB-B-W66	42,80	
			4.84	3.50	1.26			187.39		94.36
	M30x2	22L	125	91	34	QRC-HP-25-F-22LB-BT-W66	90,90	QRC-HP-25-M-22LB-B-W66	44	
			4.92	3.58	1.34			200.40		97
	M36x2	28L	125	91	34	QRC-HP-25-F-28LB-BT-W66	85,40	QRC-HP-25-M-28LB-B-W66	48,10	
			4.92	3.58	1.34			188.27		106.04
	M30x2	20S	129	95	38	QRC-HP-25-F-20SB-BT-W66	83,50	QRC-HP-25-M-20SB-B-W66	47,40	
			5.08	3.74	1.50			184.09		104.50
M36x2	25S	129	95	38	QRC-HP-25-F-25SB-BT-W66	89	QRC-HP-25-M-25SB-B-W66	52,40		
		5.08	3.74	1.50			196.21		115.52	
M42x2	30S	131	97	40	QRC-HP-25-F-30SB-BT-W66	111,90	QRC-HP-25-M-30SB-B-W66	63,40		
		5.16	3.82	1.57			246.70		139.77	

* Available on request.

Note: The connection of the two halves of a coupling is achieved depending on the type. It is important to observe the positive engagement of plug-type couplings and the secure tightening of screw-type couplings to the limit stop of the thread. Forced or improper separation will result in malfunction of the coupling.



Series HP • Dust Protection

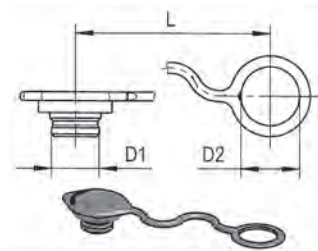
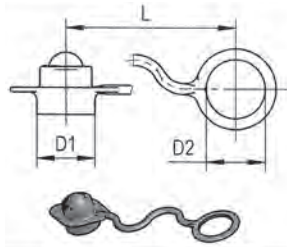

HP/HU

Dimensions (mm/in)			Material	Dust Cap for Male Tip
D1	D2	L		Ordering Codes
28	27	134	Plastic (Colour: Red)	QRC-HP-12-DM-27-K/1-RD
1.10	1.06	5.28		

Dimensions (mm/in)			Material	Dust Plug for Female Body
D1	D2	L		Ordering Codes
22	27	135	Plastic (Colour: Red)	QRC-HP-12-DF-27-K/1-RD
.87	1.06	5.31		

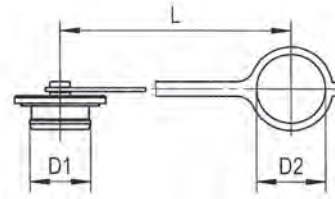
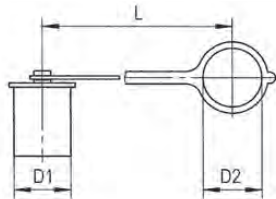

Dimensions (mm/in)			Material	Dust Cap for Male Tip
D1	D2	L		Ordering Codes
22	22	125	Plastic (Colour: Red)	QRC-HP-10-DM-22-K-RD
.87	.87	4.92		
33	37	190	Plastic (Colour: Red)	QRC-HP-19-DM-37-K-RD
1.30	1.46	7.48		
36	41	190	Plastic (Colour: Red)	QRC-HP-25-DM-41-K-RD
1.42	1.61	7.48		

Dimensions (mm/in)			Material	Dust Plug for Female Body
D1	D2	L		Ordering Codes
18	22	125	Plastic (Colour: Red)	QRC-HP-10-DF-22-K-RD
.71	.87	4.92		
30	37	190	Plastic (Colour: Red)	QRC-HP-19-DF-37-K-RD
1.18	1.46	7.48		
36	41	190	Plastic (Colour: Red)	QRC-HP-25-DF-41-K-RD
1.42	1.61	7.48		

Series HU • Dust Protection

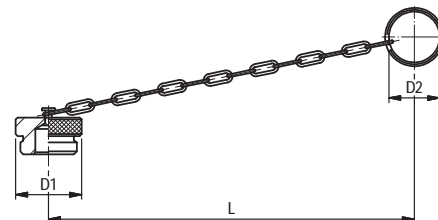
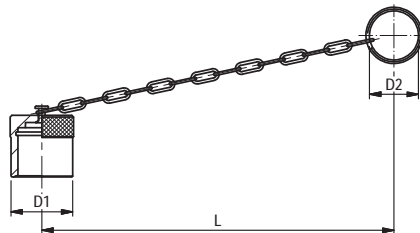

Dimensions (mm/in)			Material	Dust Cap for Male Tip
D1	D2	L		Ordering Codes
38	32	205	Aluminium with chain	QRC-IA-12-DM-32/CN-W89-SI
1.50	1.26	8.07		

Dimensions (mm/in)			Material	Dust Plug for Female Body
D1	D2	L		Ordering Codes
38	32	205	Aluminium with chain	QRC-IA-12-DF-32/CN-W89-SI
1.50	1.26	8.07		

In addition to the standard colours as stated above, plastic dust caps are also available in blue, green, yellow and black. Please use the color codes BU, GN, YE and BK respectively instead of RD.



Series UX • Carbon Steel
Product Description

Push/Pull Push-to-Connect couplings of the UX series from STAUFF consist of a female body in a short or long version and are used for quick and easy connection (push) and disconnection of tubes, pipes and hoses by hand, i.e. without tools. The female body can be connected with the male tip under pressure and also includes a breakaway function.

The Series was developed in accordance to ISO 7241-1 A and is available in the following nominal size 12 (1/2") and can be connected with male tips of the Series HP-12 or Series IA-12.

The proven design is suitable for use in agricultural and forestry machinery and hydraulic attachments. Other applications may, depending on the pressure and flow characteristics, include heavy-duty tractors and tippers.

Features

- poppet valve
(open automatically when coupled, within rated working pressure, to keep the flow laminar)
- Zinc-Plating and Thick-Film-Passivation (Chrome III)
- High-flow valve unit with return volumetric flow up to 240 l/min
- Push-pull function
- can be installed as a breakaway coupling
- a low coupling and uncoupling force required

Applications

Agricultural and Forestry Machinery

Top Features

Connect Under pressure



Designed for secure connection

UX



Series UX ▪ Carbon Steel

Material	Carbon Steel
Surface Finishing	Zinc-Plating and Thick-Film-Passivation (Chrome III)
Standard Seal Material(s)	NBR (Buna-N®), PTFE ²
Working Temperature	-30° C ... +100° C / -22° F ... +212° F
Valve Design	Poppet Valve
Connection	Push
Disconnection	Pull
Connect Under Pressure	Female Body up to max. 2,5 bar / 36 PSI, ISO-A Male Tip up to the max. Working Pressure allowed
Application	Agricultural and Forestry Machinery
ISO Interchange	ISO 7241-1 Series A, Size 12,5

² Alternative seal materials are available on request.



The Series UX coupling sleeve is available in two different overall lengths and is therefore compatible with the common commercially available built-in couplings.

Technical Data

UX

Series	BG	DN Zoll	DN metric	Q _{max}		Working Pressure		Bursting Pressure Connected*		Female Body		Male Tip		Spillage	
				ISO 4397	l/min	US GPM	bar	PSI	bar	PSI	bar	PSI	bar	PSI	ml
UX-12	3	1/2"	12,5	100	26.42	250	3626	1000	14504	1000	14504	1000	14504	1,7	.0575

The indicated pressure ratings only apply to the coupling itself and depend on the connection type.
 * in connection with QRC-HP-12-M-....

Flow Characteristics

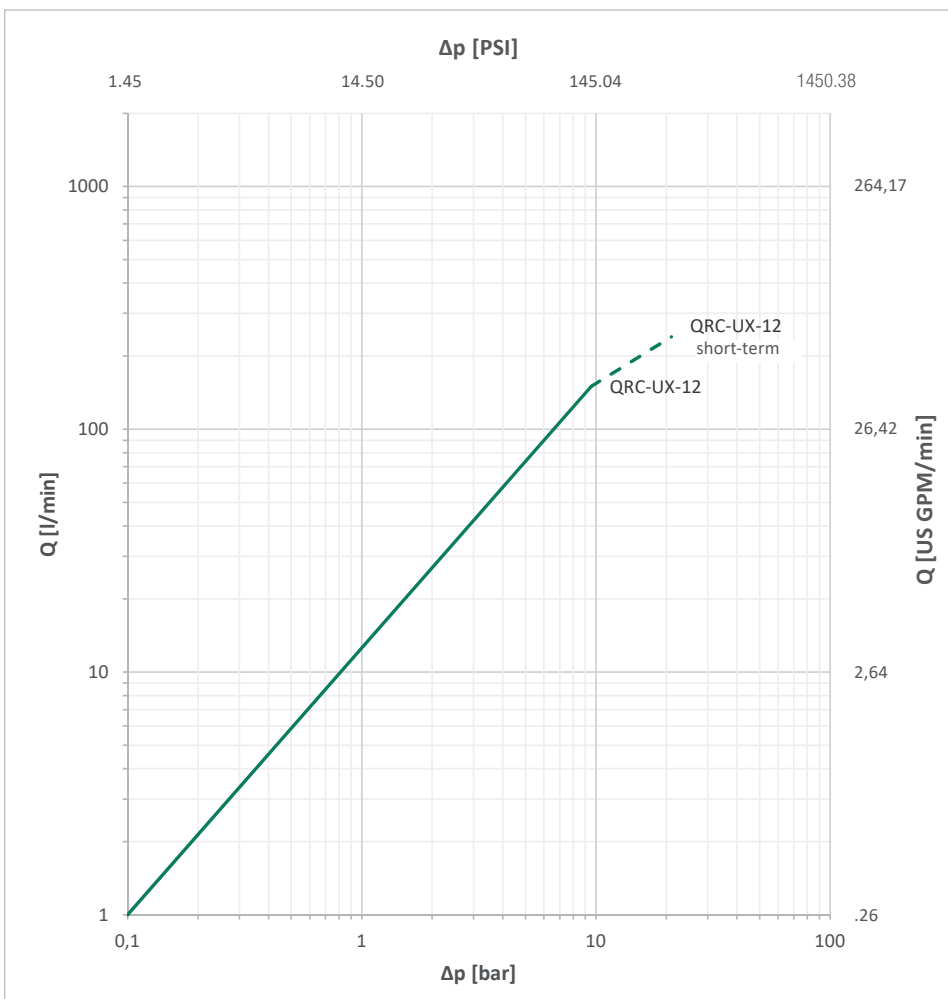

Please note: Unless otherwise stated, all flow characteristics have been determined with hydraulic oil with a kinematic viscosity of 28,8 - 35,2 mm²/s (28,8 - 35,2 cSt) and are only valid for components with non-reducing connections.



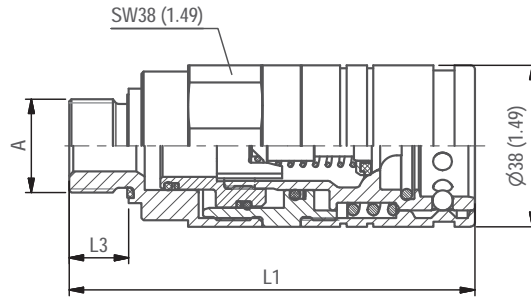

SW: Width across flats. All dimensions in mm (inch).

Series UX-S-10 ▪ BG 3 ▪ Nominal Size 12,5
UX

Port A	Dimensions (^{mm} / _{in})					Female Body Ordering Codes	Weight (^{kg} / _{lbs}) ca. per 100
	ØD2	L1	L2	L3	L4		
Male Thread according to EN ISO 9974-2, DIN 3852 T11 Shape E							
	M22x1,5		95,5		14	QRC-UX-S-12-F-M22MWD-S1-W66-SM	49,50
			3,76		.55		109,13
Male Thread according to ISO 6149, DIN 3852 T3, Shape C							
	M22x1,5		94		13	QRC-UX-S-12-F-M22MOR-S1-W66-SM	49,20
			3,70		.51		108,47
Male Thread with 24° Conical Bore - Bulkhead - Shape W according to DIN 3861							
	M18x1,5	12L	112,5 4,43		30 1,18	QRC-UX-S-12-F-12LB-S1-W66	50,20 110,67
	M22x1,5	15L	109,5 4,31		27 1,06	QRC-UX-S-12-F-15LB-S1-W66	51,30 113,10
	M26x1,5	18L	109,5 4,31		27 1,06	QRC-UX-S-12-F-18LB-S1-W66	52,70 116,18

Dust Cover Clips: Please see page 188.

Note: The connection of the two halves of a coupling is achieved depending on the type. It is important to observe the positive engagement of plug-type couplings and the secure tightening of screw-type couplings to the limit stop of the thread. Forced or improper separation will result in malfunction of the coupling.



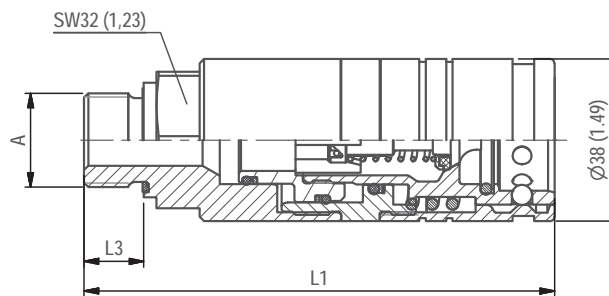

SW: Width across flats. All dimensions in mm (inch).

Series UX-L-10 • BG 3 • Nominal Size 12,5

UX

Port A	Dimensions (^{mm} / _{in})					Female Body Ordering Codes	Weight (^{kg} / _{lbs}) ca. per 100
	ØD2	L1	L2	L3	L4		
Male Thread according to EN ISO 9974-2, DIN 3852 T11 Shape E							
	M22x1,5		110,3		14	QRC-UX-L-12-F-M22MWD-S1-W66-SM	59,60
			4.34		.55		131.40
Male Thread according to ISO 6149, DIN 3852 T3, Shape C							
	M18x1,5		110,8		14	QRC-UX-L-12-F-M18MOR-S1-W66-SM	61,90
			4.36		.55		136.47
	M22 x 1,5		110,8		14	QRC-UX-L-12-F-M22MOR-S1-W66-SM	59,60
			4.36		.55		131.40
Male Thread with 24° Conical Bore - Bulkhead - Shape W according to DIN 3861							
	M18x1,5	12L	121,5		26	QRC-UX-L-12-F-12LB-S1-W66	60,20
			4.78		1.02		132.72
	M22 x 1,5	15L	123,5		26	QRC-UX-L-12-F-15LB-S1-W66	62,90
			4.86		1.02		138.67
Female Thread according to ISO 1179 - ANSI B 1.20.3 - SAE J1926-1 - ISO 11926-1							
	G1/2"		107,3		15	QRC-UX-L-12-F-G08-S1-W66	60,40
			4.22		.59		133.16
	NPTF 1/2"-14		107,3			QRC-UX-L-12-F-NF08-S1-W66	60,80
			4.22				134.04
UNF 3/4"-16		107,3		14	QRC-UX-L-12-F-U08-S1-W66	60,90	
		4.22		.55		134.26	
Banjo screw for banjos according to DIN 7643							
M22x1,5	18	134,8		39	14	QRC-UX-L-12-F-BS22-S1-W66	61,20
		5.31		1.54	.55		134.92

Dust Cover Clips: Please see page 188.

Note: The connection of the two halves of a coupling is achieved depending on the type. It is important to observe the positive engagement of plug-type couplings and the secure tightening of screw-type couplings to the limit stop of the thread. Forced or improper separation will result in malfunction of the coupling.



Product Description

Push-to-Connect couplings of the IA Series from STAUFF consist of a male tip and a female body which are used for quick and easy connection (push) and disconnection of tubes, pipes and hoses by hand, i.e. without tools.

The Series was developed according to ISO 7241-1 A in the following nominal sizes 06, 10, 12, 19, 25, 31, 38, 51 (1/4" - 2").

The proven design is suitable for use in agricultural and forestry machinery and hydraulic attachments. Other applications may, depending on the pressure and flow characteristics, include construction equipment, oil tools, oil equipment steel mill machinery, and other demanding industrial hydraulic applications.

Features

- poppet valve
- Coupling made from carbon steel with Zinc/Nickel surface coating
- Integrated locking system preventing unintentional release of the coupling
- ISO Interchange acc. to ISO 7241-1 Series A
- Compatible with the HP Series

Applications



Agricultural and Forestry Machinery



Industrial Hydraulic

Top Features



Zinc/Nickel coating



Designed for secure connection



Series IA ▪ Carbon Steel

Material	Carbon Steel
Surface Finishing	Zinc-Nickel
Standard Seal Material(s)	NBR (Buna-N®) ²
Working Temperature	-25° C ... +100° C / -13° F ... +212° F
Valve Design	Poppet Valve
Connection	Push and actuate Push Sleeve
Disconnection	Actuate Push Sleeve
Connect Under Pressure	not allowed
Application	Agricultural and Forestry Machinery
ISO Interchange	ISO 7241-1, Series A



² Alternative seal materials are available on request.

Technical Data

Series	BG	DN Zoll	DN metric ISO 4397	Q _{max}		Working Pressure		Bursting Pressure Connected		Female Body		Male Tip		Spillage	
				l/min	US GPM	bar	PSI	bar	PSI	bar	PSI	bar	PSI	ml	fl oz
IA-06	1	1/4"	6,3	4,5	1.19	315	4569	1600	23206	1600	23206	1600	23206	0,5	.0169
IA-10	2	3/8"	10	34,5	9.11	315	4569	1500	21756	1500	21756	1500	21756	1,9	.0642
IA-12	3	1/2"	12,5	67,5	17.83	250	3626	1520	22046	1250	18130	1000	14504	2,7	.0913
IA-19	4	3/4"	19 (20)	159	42.00	250	3626	1000	14504	1000	14504	1000	14504	9,3	.3145
IA-25	6	1"	25	283,5	74.89	200	2901	1000	14504	1000	14504	1000	14504	16	.5410
IA-31	7	1 1/4"	31	432	114.12	200	2901	800	11603	800	11603	800	11603	30	10.144
IA-38	8	1 1/2"	38	758	200.24	160	2321	640	9282	640	9282	640	9282	54	18.260
IA-51	9	2"	51	1135	299.84	150	2176	252	3655	252	3655	252	3655	120	40.577

The indicated pressure ratings only apply to the coupling itself and depend on the connection type.

Flow Characteristics

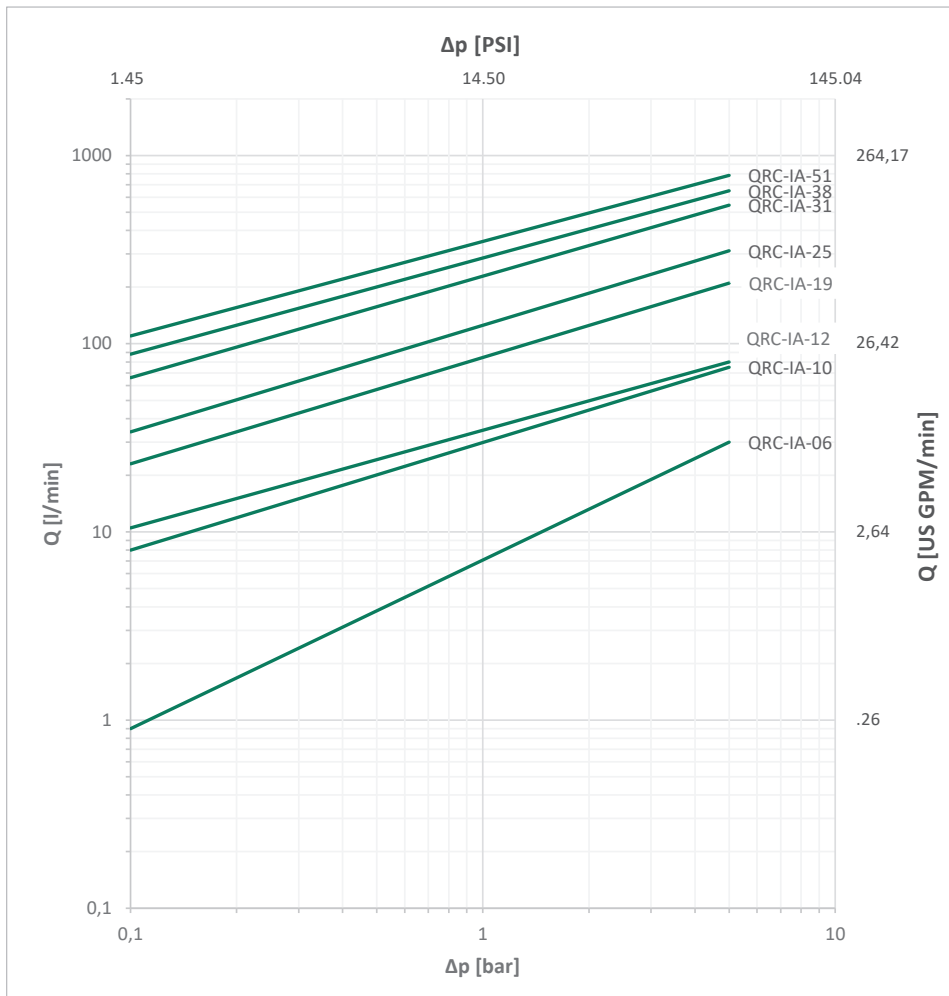

Please note: Unless otherwise stated, all flow characteristics have been determined with hydraulic oil with a kinematic viscosity of 28,8 - 35,2 mm²/s (28,8 - 35,2 cSt) and are only valid for components with non-reducing connections.



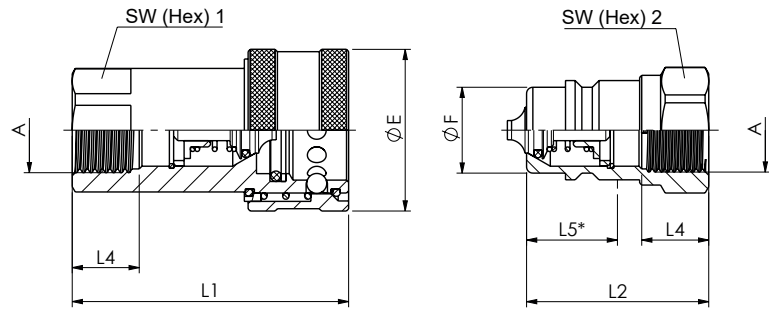

SW: Width across flats. All dimensions in mm (inch). Drawing similar Series IA-12.
* Insertion Male Tip.

Series IA-06 • BG 1 • Nominal Size 6,3

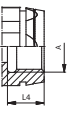
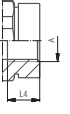
Port A	Dimensions (mm/in)								Female Body Ordering Codes	Weight (kg/lbs) ca. per 100	Male Tip Ordering Codes	Weight (kg/lbs) ca. per 100	
	ØE	ØF	L1	L2	L4 min	L5	SW1	SW2					
Female Thread according to DIN 3852 - ISO 1179-1 - ANSI B 1.20.3													
	G1/4"	26 1.02	11,8 .46	50 1.97	35,5 1.40	12 .47	13,7 .54	19 .75	19 .75	QRC-IA-06-F-G04-BT-W3	11,62 25,62	QRC-IA-06-M-G04-B-W3	3,56 7,85
	NPTF 1/4" -18	26 1.02	11,8 .46	50 1.97	35,5 1.40		13,7 .54	19 .75	19 .75	QRC-IA-06-F-NF04-BT-W3	11,62 25,62	QRC-IA-06-M-NF04-B-W3	3,56 7,85
Female Thread according to SAE J 1926-1													
	UNF 9/16" -18	26 1.02	11,8 .46	50 1.97	35,5 1.40	12,7 .50	13,7 .54	19 .75	19 .75	QRC-IA-06-F-U06-BT-W3	11,32 24,96	QRC-IA-06-M-U06-B-W3	3,31 7,30

Series IA-10 • BG 2 • Nominal Size 10

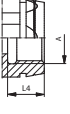
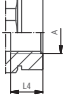
Port A	Dimensions (mm/in)								Female Body Ordering Codes	Weight (kg/lbs) ca. per 100	Male Tip Ordering Codes	Weight (kg/lbs) ca. per 100	
	ØE	ØF	L1	L2	L4 min	L5	SW1	SW2					
Female Thread according to DIN 3852 - ISO 1179-1 - ANSI B 1.20.3													
	G 3/8"	31,5 1.24	17,3 .68	56 2.20	36,5 1.44	12,6 .50	18 .71	22 .87	22 .87	QRC-IA-10-F-G06-BT-W3	15,32 33,77	QRC-IA-10-M-G06-B-W3	5,02 11,07
	NPTF 3/8" -18	31,5 1.24	17,3 .68	56 2.20	36,5 1.44		18 .71	22 .87	22 .87	QRC-IA-10-F-NF06-BT-W3	15,32 33,77	QRC-IA-10-M-NF06-B-W3	5,02 11,07
Female Thread according to SAE J 1926-1													
	UNF 9/16" -18	31,5 1.24	17,3 .68	56 2.20	36,5 1.44	12,7 .50	18 .71	22 .87	22 .87	QRC-IA-10-F-U06-BT-W3	13,81 30,45	QRC-IA-10-M-U06-B-W3	4,31 9,50
	UNF 3/4" -16	31,5 1.24	17,3 .68	56 2.20	36,5 1.44	14 .55	18 .71	22 .87	22 .87	QRC-IA-10-F-U08-BT-W3	14,82 32,67	QRC-IA-10-M-U08-B-W3	4,54 10,01

Note: The connection of the two halves of a coupling is achieved depending on the type. It is important to observe the positive engagement of plug-type couplings and the secure tightening of screw-type couplings to the limit stop of the thread. Forced or improper separation will result in malfunction of the coupling.



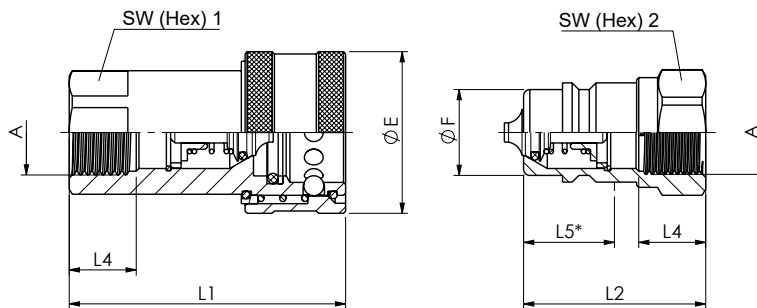

SW: Width across flats. All dimensions in mm (inch). Drawing similar Series IA-12.
* Insertion Male Tip.

Series IA-12 • BG 3 • Nominal Size 12,5

Port A	Dimensions (mm/in)									Female Body Ordering Codes	Weight (kg/lbs) ca. per 100	Male Tip Ordering Codes	Weight (kg/lbs) ca. per 100
	ØE	ØF	L1	L2	L4 min	L5	SW1	SW2					
Female Thread according to DIN 3852 - ISO 1179-1 - ANSI B 1.20.3 - ISO 9974-1													
	M22x1,5	38,6 1.52	20,5 .81	66 2.60	43,5 1.71	14 .55	21,5 .85	27 1.06	27 1.06	QRC-IA-12-F-M22-BT-W3	27,02 59.57	QRC-IA-12-M-M22-B-W3	8,77 19.33
	G 1/2"	38,6 1.52	20,5 .81	66 2.60	43,5 1.71		21,5 .85	27 1.06	27 1.06	QRC-IA-12-F-G08-BT-W3	27,02 59.57	QRC-IA-12-M-G08-B-W3	8,77 19.33
	NPTF 1/2" -14	38,6 1.52	20,5 .81	66 2.60	43,5 1.71		21,7 .85	27 1.06	27 1.06	QRC-IA-12-F-NF08-BT-W3	25,64 56.53	QRC-IA-12-M-NF08-B-W3	8,60 18.96
	NPTF 3/4" -14	38 1.5	20,55 .81	70 2.76	63,5 2.5		21,5 .85	27 1.06	27 1.06	QRC-IA-12-F-NF12-BT-W3	35,30 77.82	QRC-IA-12-M-NF12-B-W3	9,80 21.61
Female Thread according to SAE J 1926-1													
	UNF 3/4" -16	38,6 1.52	20,5 .81	66 2.60	43,5 1.71	14,3 .56	21,7 .85	27 1.06	27 1.06	QRC-IA-12-F-U08-BT-W3	27,40 60.41	QRC-IA-12-M-U08-B-W3	10,10 22.27
	UNF 7/8" -14	38,6 1.52	20,5 .81	66 2.60	43,5 1.71	16,7 .66	21,7 .85	27 1.06	27 1.06	QRC-IA-12-F-U10-BT-W3	26,00 57.32	QRC-IA-12-M-U10-B-W3	10,10 22.27

Series IA-19 • BG 4 • Nominal Size 19

Port A	Dimensions (mm/in)									Female Body Ordering Codes	Weight (kg/lbs) ca. per 100	Male Tip Ordering Codes	Weight (kg/lbs) ca. per 100
	ØE	ØF	L1	L2	L4 min	L5	SW1	SW2					
Female Thread according to DIN 3852 - ISO 1179-1 - ANSI B 1.20.3													
	G 3/4"	48 1.89	29,1 1.15	80,2 3.16	57 2.24	18 .71	26,8 1.06	34 1.34	34 1.34	QRC-IA-19-F-G12-BT-W3	51,37 113.25	QRC-IA-19-M-G12-B-W3	19,92 43.92
	NPTF 3/4" -14	48 1.89	29,1 1.15	80,2 3.16	57 2.24		26,8 1.06	34 1.34	34 1.34	QRC-IA-19-F-NF12-BT-W3	51,37 113.25	QRC-IA-19-M-NF12-B-W3	19,92 43.92

Note: The connection of the two halves of a coupling is achieved depending on the type. It is important to observe the positive engagement of plug-type couplings and the secure tightening of screw-type couplings to the limit stop of the thread. Forced or improper separation will result in malfunction of the coupling.



Series IA-25 ▪ BG 6 ▪ Nominal Size 25

Port A	Dimensions (mm/in)									Female Body Ordering Codes	Weight (kg/lbs) ca. per 100	Male Tip Ordering Codes	Weight (kg/lbs) ca. per 100
	ØE	ØF	L1	L2	L4 min	L5	SW1	SW2					
Female Thread according to DIN 3852 - ISO 1179-1 - ANSI B 1.20.3													
	G 1"	56	34,3	94	59,5	18	33	41	41	QRC-IA-25-F-G16-BT-W3	78,89	QRC-IA-25-M-G16-B-W3	25,68
		2.20	1.35	3.70	2.34	.71	1.30	1.61	1.61		173.92		56.61
	NPTF 1" -11 1/2	56	34,3	94	59,5		33	41	41	QRC-IA-25-F-NF16-BT-W3	78,89	QRC-IA-25-M-NF16-B-W3	25,68
		2.20	1.35	3.70	2.34		1.30	1.61	1.61		173.92		56.61

Series IA-31 ▪ BG 7 ▪ Nominal Size 31,5

Port A	Dimensions (mm/in)									Female Body Ordering Codes	Weight (kg/lbs) ca. per 100	Male Tip Ordering Codes	Weight (kg/lbs) ca. per 100
	ØE	ØF	L1	L2	L4 min	L5	SW1	SW2					
Female Thread according to DIN 3852 - ISO 1179-1 - ANSI B 1.20.3													
	G 1 1/4"	69,8	45	117	75	24	41,3	50	50	QRC-IA-31-F-G20-BT-W3	128,33	QRC-IA-31-M-G20-B-W3	54,71
		2.75	1.77	4.61	2.95	.94	1.63	1.97	1.97		282.92		120.61
	NPTF 1 1/4" -11 1/2	69,8	45	117	75		41,3	50	50	QRC-IA-31-F-NF20-BT-W3	130,31	QRC-IA-31-M-NF20-B-W3	56,6
		2.75	1.77	4.61	2.95		1.63	1.97	1.97		287.28		124.78

Series IA-38 ▪ BG 8 ▪ Nominal Size 38

Port A	Dimensions (mm/in)									Female Body Ordering Codes	Weight (kg/lbs) ca. per 100	Male Tip Ordering Codes	Weight (kg/lbs) ca. per 100
	ØE	ØF	L1	L2	L4 min	L5	SW1	SW2					
Female Thread according to DIN 3852 - ISO 1179-1 - ANSI B 1.20.3													
	G 1 1/2"	84,5	55	133	83,5	27	48,8	60	60	QRC-IA-38-F-G24-BT-W3	216,48	QRC-IA-38-M-G24-B-W3	87,06
		3.33	2.17	5.24	3.29	1.06	1.92	2.36	2.36		477.26		191.93
	NPTF 1 1/2" -11 1/2	84,5	55	133	83,5		48,8	60	60	QRC-IA-38-F-NF24-BT-W3	218,41	QRC-IA-38-M-NF24-B-W3	89,1
		3.33	2.17	5.24	3.29		1.92	2.36	2.36		481.51		196.43

Series IA-51 ▪ BG 9 ▪ Nominal Size 51

Port A	Dimensions (mm/in)									Female Body Ordering Codes	Weight (kg/lbs) ca. per 100	Male Tip Ordering Codes	Weight (kg/lbs) ca. per 100
	ØE	ØF	L1	L2	L4 min	L5	SW1	SW2					
Female Thread according to DIN 3852 - ISO 1179-1 - ANSI B 1.20.3													
	G 2"	99	65	165	105	26		75	75	QRC-IA-51-F-G32-BT-W3	500	QRC-IA-51-M-G32-B-W3	180,40
		3.90	2.56	6.50	4.13	1.02		2.95	2.95		1102.31		397.71
	NPTF 2" -11 1/2	99	65	165	105	26		75	75	QRC-IA-51-F-NF32-BT-W3	501	QRC-IA-51-M-NF32-B-W3	182
		3.90	2.56	6.50	4.13	1.02		2.95	2.95		1104.52		401.24

Note: The connection of the two halves of a coupling is achieved depending on the type. It is important to observe the positive engagement of plug-type couplings and the secure tightening of screw-type couplings to the limit stop of the thread. Forced or improper separation will result in malfunction of the coupling.



Series IA ▪ Dust Protection

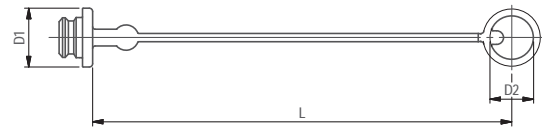
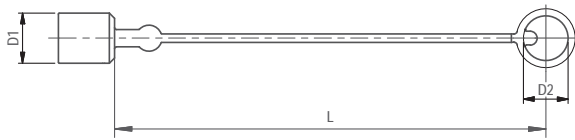

Dimensions (mm/in)			Material	Dust Cap for Male Tip
D1	D2	L		Ordering Codes
11	6	110	Plastic (Colour: Red)	QRC-IA-06-DM-19-KI-RD
.43	.24	4.33		
24	22	220	Plastic (Colour: Red)	QRC-IA-10-DM-22-KI-RD
.93	.87	8.66		
29	26	250	Plastic (Colour: Red)	QRC-IA-12-DM-26-KI-RD
1.14	1.02	9.84		
36,5	36	270	Plastic (Colour: Red)	QRC-IA-19-DM-36-KI-RD
1.44	1.42	10.63		
36	28	235	Plastic (Colour: Red)	QRC-IA-25-DM-28-KI-RD
1.42	1.10	9.25		

Dimensions (mm/in)			Material	Dust Plug for Female Body
D1	D2	L		Ordering Codes
10	6	110	Plastic (Colour: Red)	QRC-IA-06-DF-19-KI-RD
.39	.24	4.33		
28	22	220	Plastic (Colour: Red)	QRC-IA-10-DF-22-KI-RD
1.10	.87	8.66		
35	26	250	Plastic (Colour: Red)	QRC-IA-12-DF-26-KI-RD
1.38	1.02	9.84		
42	36	270	Plastic (Colour: Red)	QRC-IA-19-DF-36-KI-RD
1.65	1.42	10.63		
41	28	235	Plastic (Colour: Red)	QRC-IA-25-DF-28-KI-RD
1.61	1.10	9.25		

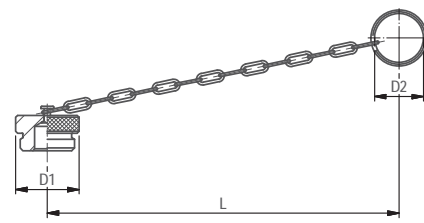
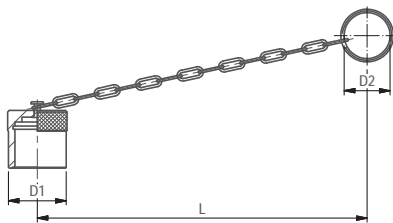

Dimensions (mm/in)			Material	Dust Cap for Male Tip
D1	D2	L		Ordering Codes
19	30	180	Aluminium with chain	QRC-IA-06-DM-30/CN-W89-SI
.75	1.18	7.09		
30	33	200	Aluminium with chain	QRC-IA-10-DM-33/CN-W89-SI
1.18	1.30	7.87		
38	32	205	Aluminium with chain	QRC-IA-12-DM-32/CN-W89-SI
1.50	1.26	8.07		
45	47	275	Aluminium with chain	QRC-IA-19-DM-47/CN-W89-SI
1.77	1.85	10.83		
45	41	290	Aluminium with chain	QRC-IA-25-DM-41/CN-W89-SI
1.77	1.61	11.42		
70	47	275	Aluminium with chain	QRC-IA-31-DM-47/CN-W89-SI
2.76	1.85	10.83		

Dimensions (mm/in)			Material	Dust Plug for Female Body
D1	D2	L		Ordering Codes
19	30	160	Aluminium with chain	QRC-IA-06-DF-30/CN-W89-SI
.75	1.18	6.30		
30	33	200	Aluminium with chain	QRC-IA-10-DF-33/CN-W89-SI
1.18	1.30	7.87		
38	32	205	Aluminium with chain	QRC-IA-12-DF-32/CN-W89-SI
1.50	1.26	8.07		
45	47	275	Aluminium with chain	QRC-IA-19-DF-47/CN-W89-SI
1.77	1.85	10.83		
43	41	240	Aluminium with chain	QRC-IA-25-DF-41/CN-W89-SI
1.69	1.61	9.45		
70	47	275	Aluminium with chain	QRC-IA-31-DF-47/CN-W89-SI
2.76	1.85	10.83		

In addition to the standard colours as stated above, plastic dust caps are also available in blue, green, yellow and black. Please use the color codes BU, GN, YE and BK respectively instead of RD.



Series IA • Stainless Steel
Product Description

Push-to-Connect couplings of the IA Series made of stainless steel from STAUFF consist of a male tip and a female body which are used for quick and easy connection (push) and disconnection of tubes, pipes and hoses by hand, i.e. without tools.

The Series was developed according to ISO 7241-1 A in the following nominal sizes 06, 10, 12, 19, 25, 31, 38, 51 (1/4" - 2").

The proven design is suitable for use in agricultural and forestry machinery and hydraulic attachments. Other applications may, depending on the pressure and flow characteristics, include construction equipment, oil tools, oil equipment steel mill machinery, and other demanding industrial hydraulic applications.

Features

- poppet valve
- Coupling made of stainless steel (AISI 316)
- Integrated locking system preventing unintentional release of the coupling
- ISO Interchange acc. to ISO 7241-1 Series A

Applications

Agricultural and Forestry Machinery



Industrial Hydraulic



Offshore Industry

IA
Top Features

Designed for secure connection



Series IA - Stainless Steel

Material	Stainless Steel V4A (AISI 316)
Surface Finishing	-
Standard Seal Material(s)	FKM (Viton®) ²
Working Temperature	-25° C ... +200° C / -13° F ... +392° F
Valve Design	Poppet Valve
Connection	Push and actuate Push Sleeve
Disconnection	Actuate Push Sleeve
Connect Under Pressure	not allowed
Application	Agricultural and Forestry Machinery, Industrial Hydraulic
ISO Interchange	ISO 7241-1, Series A



² Alternative seal materials are available on request.

Technical Data

Series	BG	DN Zoll Inch	DN metric ISO 4397	Q _{max}		Working Pressure		Bursting Pressure Connected		Female Body		Male Tip		Spillage	
				l/min	US GPM	bar	PSI	bar	PSI	bar	PSI	bar	PSI	ml	fl oz
IA-06	1	1/4"	6,3	17	4.49	450	6527	2900	42061	2900	42061	3200	46412	0,5	.0169
IA-10	2	3/8"	10	46	12.15	300	4351	1300	18855	1250	18130	1250	18130	1,9	.0642
IA-12	3	1/2"	12,5	90	23.78	300	4351	1350	19580	1200	17405	1200	17405	2,7	.0913
IA-19	4	3/4"	19 (20)	190	50.19	250	3626	1100	15954	1000	14504	800	11603	9,3	.3145
IA-25	6	1"	25	280	73.97	200	2901	850	12328	650	9427	600	8702	19	.6425
IA-31	7	1 1/4"	31	480	126.80	100	1450	400	5802	400	5802	400	5802	30	10.144
IA-38	8	1 1/2"	38	700	184.92	80	1160	320	4641	320	4641	320	4641	54	18.260
IA-51	9	2"	51	1000	264.17	60	870	250	3626	250	3626	250	3626	120	40.577

The indicated pressure ratings only apply to the coupling itself and depend on the connection type.

Flow Characteristics

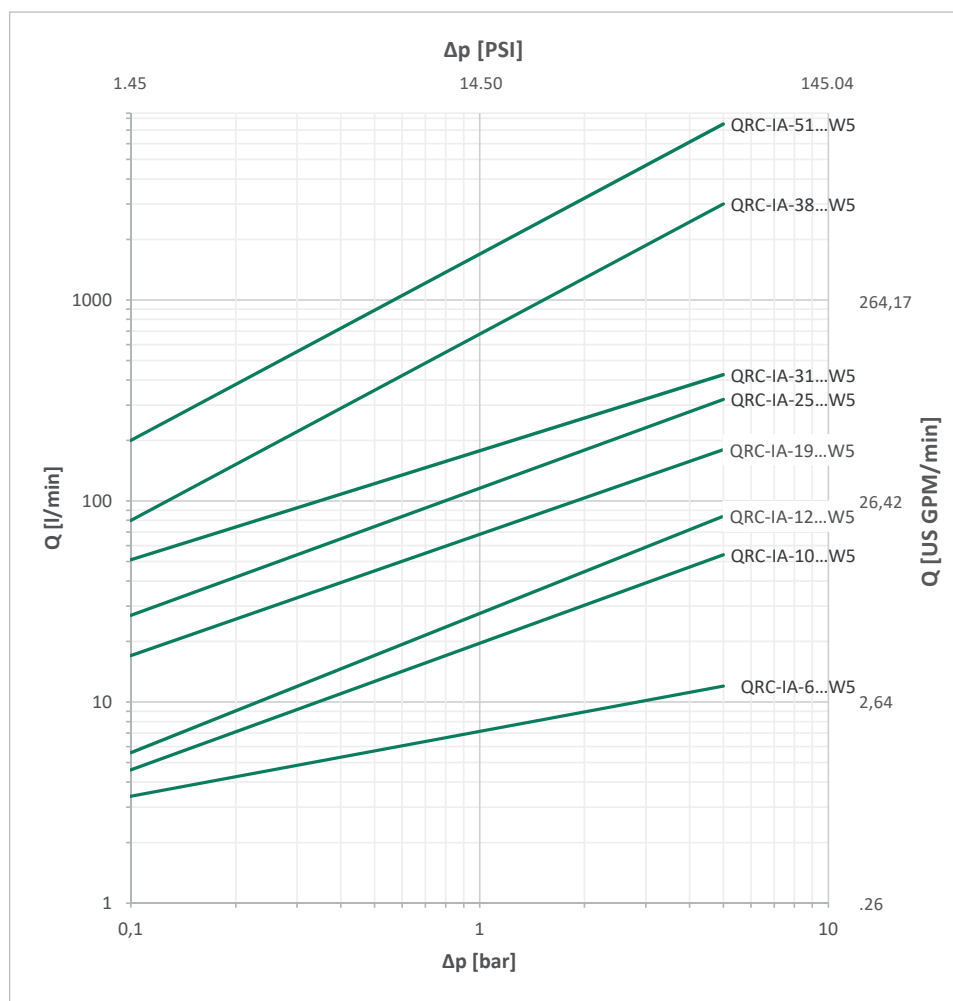

Please note: Unless otherwise stated, all flow characteristics have been determined with hydraulic oil with a kinematic viscosity of 28,8 - 35,2 mm²/s (28,8 - 35,2 cSt) and are only valid for components with non-reducing connections.



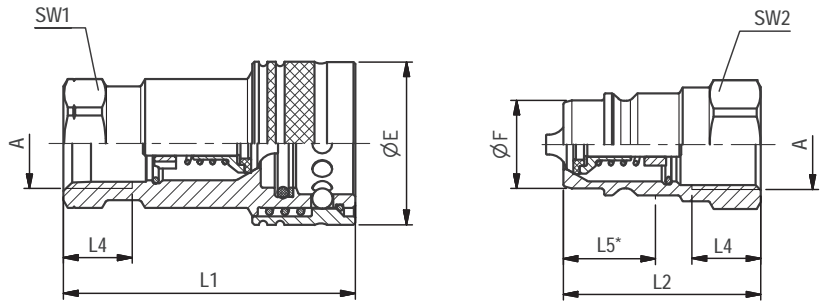

SW: Width across flats. All dimensions in mm (inch). Drawing similar Series IA-12.
* Insertion Male Tip.

Series IA-06 ▪ BG 1 ▪ Nominal Size 6,3

Port A	Dimensions (mm/in)								Female Body Ordering Codes	Weight (kg/lbs) ca. per 100	Male Tip Ordering Codes	Weight (kg/lbs) ca. per 100	
	ØE	ØF	L1	L2	L4 min	L5	SW1	SW2					
Female Thread according to DIN 3852 - ISO 1179-1 - ANSI B. 1.20.3													
	G 1/4"	26	11,85	50,5	35,5	12	14,5	19	19	QRC-IA-06-F-G04-VT-W5	11,90	QRC-IA-06-M-G04-V-W5	3,80
		1.02	.47	1.99	1.40	.47	.57	.75	.75		26.24		8.38
	NPTF 1/4" -18	26	11,85	50,5	35,5		14,5	19	19	QRC-IA-06-F-NF04-VT-W5	12	QRC-IA-06-M-NF04-V-W5	3,90
		1.02	.47	1.99	1.40		.57	.75	.75		26.46		8.60

Series IA-10 ▪ BG 2 ▪ Nominal Size 10

Port A	Dimensions (mm/in)								Female Body Ordering Codes	Weight (kg/lbs) ca. per 100	Male Tip Ordering Codes	Weight (kg/lbs) ca. per 100	
	ØE	ØF	L1	L2	L4 min	L5	SW1	SW2					
Female Thread according to DIN 3852 - ISO 1179-1 - ANSI B. 1.20.3													
	G 3/8"	30	17,3	58,5	40,5	12	17	22	22	QRC-IA-10-F-G06-VT-W5	15,70	QRC-IA-10-M-G06-V-W5	5,90
		1.18	.68	2.30	1.59	.47	.62	.87	.87		34.61		13.01
	NPTF 3/8" -18	30	17,3	58,5	40,5		17	22	22	QRC-IA-10-F-NF06-VT-W5	15,80	QRC-IA-10-M-NF06-V-W5	6
		1.18	.68	2.30	1.59		.62	.87	.87		34.83		13.23

Series IA-12 ▪ BG 3 ▪ Nominal Size 12,5

Port A	Dimensions (mm/in)								Female Body Ordering Codes	Weight (kg/lbs) ca. per 100	Male Tip Ordering Codes	Weight (kg/lbs) ca. per 100	
	ØE	ØF	L1	L2	L4 min	L5	SW1	SW2					
Female Thread according to DIN 3852 - ISO 1179-1 - ANSI B. 1.20.3													
	G 1/2"	37,9	20,55	68	46	14	21,5	27	27	QRC-IA-12-F-G08-VT-W5	29,50	QRC-IA-12-M-G08-V-W5	9,70
		1.49	.81	2.68	1.81	.55	.85	1.06	1.06		65.04		21.38
	NPTF 1/2" -14	37,9	20,55	68	46		21,5	27	27	QRC-IA-12-F-NF08-VT-W5	29,70	QRC-IA-12-M-NF08-V-W5	9,90
		1.49	.81	2.68	1.81		.85	1.06	1.06		65.48		21.83

Series IA-19 ▪ BG 4 ▪ Nominal Size 19

Port A	Dimensions (mm/in)								Female Body Ordering Codes	Weight (kg/lbs) ca. per 100	Male Tip Ordering Codes	Weight (kg/lbs) ca. per 100	
	ØE	ØF	L1	L2	L4 min	L5	SW1	SW2					
Female Thread according to DIN 3852 - ISO 1179-1 - ANSI B. 1.20.3													
	G 3/4"	45	29,1	84,3	57	16	20,8	34	34	QRC-IA-19-F-G12-VT-W5	51	QRC-IA-19-M-G12-V-W5	16,50
		1.77	1.14	84	2.24	.63	.82	1.34	1.34		112.44		36.38
	NPTF 3/4" -14	45	29,1	84,3	57		20,8	34	34	QRC-IA-19-F-NF12-VT-W5	51,30	QRC-IA-19-M-NF12-V-W5	16,80
		1.77	1.14	3.32	2.24		.82	1.34	1.34		113.10		37.04

Note: The connection of the two halves of a coupling is achieved depending on the type. It is important to observe the positive engagement of plug-type couplings and the secure tightening of screw-type couplings to the limit stop of the thread. Forced or improper separation will result in malfunction of the coupling.



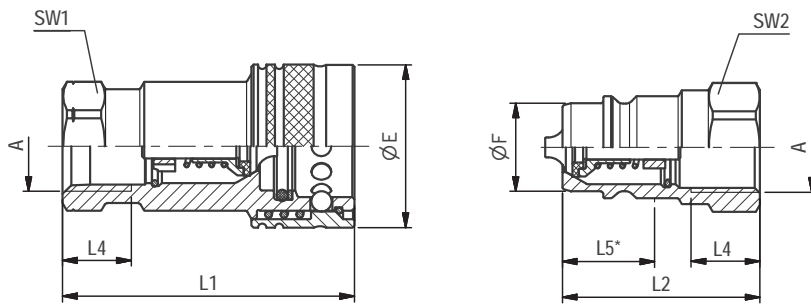

SW: Width across flats. All dimensions in mm (inch). Drawing similar Series IA-12.
* Insertion Male Tip.

Series IA-25 ▪ BG 6 ▪ Nominal Size 25

Port A	Dimensions (mm/in)								Female Body Ordering Codes	Weight (kg/lbs) ca. per 100	Male Tip Ordering Codes	Weight (kg/lbs) ca. per 100
	ØE	ØF	L1	L2	L4 min	L5	SW1	SW2				
Female Thread according to DIN 3852 - ISO 1179-1 - ANSI B. 1.20.3												
 G 1"	52	34,35	97	63,5	18	33,5	41	41	QRC-IA-25-F-G16-VT-W5	63,60	QRC-IA-25-M-G16-V-W5	28,50
	2,06	1,35	3,82	2,50	,71	1,32	1,61	1,61		140,21		62,83
 NPTF 1" -11 1/2	52	34,35	97	63,5		33,5	41	41	QRC-IA-25-F-NF16-VT-W5	64,30	QRC-IA-25-M-NF16-V-W5	29,20
	2,06	1,35	3,82	2,50		1,32	1,61	1,61		141,76		64,37

Series IA-31 ▪ BG 7 ▪ Nominal Size 31,5

Port A	Dimensions (mm/in)								Female Body Ordering Codes	Weight (kg/lbs) ca. per 100	Male Tip Ordering Codes	Weight (kg/lbs) ca. per 100
	ØE	ØF	L1	L2	L4 min	L5	SW1	SW2				
Female Thread according to DIN 3852 - ISO 1179-1 - ANSI B. 1.20.3												
 G 1 1/4"	70	45	115	69	20	34	50	50	QRC-IA-31-F-G20-VT-W5	147	QRC-IA-31-M-G20-V-W5	48
	2,75	1,77	4,53	2,72	,79	1,34	1,97	1,97		324,08		105,82
 NPTF 1 1/4" -11 1/2	70	45	115	69		34	50	50	QRC-IA-31-F-NF20-VT-W5	148,50	QRC-IA-31-M-NF20-V-W5	49,50
	2,75	1,77	4,53	2,72		1,34	1,97	1,97		327,39		109,13

Series IA-38 ▪ BG 8 ▪ Nominal Size 38

Port A	Dimensions (mm/in)								Female Body Ordering Codes	Weight (kg/lbs) ca. per 100	Male Tip Ordering Codes	Weight (kg/lbs) ca. per 100
	ØE	ØF	L1	L2	L4 min	L5	SW1	SW2				
Female Thread according to DIN 3852 - ISO 1179-1 - ANSI B. 1.20.3												
 G 1 1/2"	80	55	123	73	22	50	60	60	QRC-IA-38-F-G24-VT-W5	198	QRC-IA-38-M-G24-V-W5	73,80
	3,17	2,16	4,84	2,87	,87	1,97	2,36	2,36		436,52		162,70
 NPTF 1 1/2" -11 1/2	80	55	123	73		50	60	60	QRC-IA-38-F-NF24-VT-W5	202	QRC-IA-38-M-NF24-V-W5	87
	3,17	2,16	4,84	2,87		1,97	2,36	2,36		445,33		191,80

Series IA-51 ▪ BG 9 ▪ Nominal Size 51

Port A	Dimensions (mm/in)								Female Body Ordering Codes	Weight (kg/lbs) ca. per 100	Male Tip Ordering Codes	Weight (kg/lbs) ca. per 100
	ØE	ØF	L1	L2	L4 min	L5	SW1	SW2				
Female Thread according to DIN 3852 - ISO 1179-1 - ANSI B. 1.20.3												
 G 2"	102	65,1	147	90	24	57	70	70	QRC-IA-51-F-G32-VT-W5	349	QRC-IA-51-M-G32-V-W5	116,80
	4,01	2,56	5,79	3,54	,94	2,24	2,75	2,75		769,41		257,50
 NPTF 2" -11 1/2	102	65,1	147	90		57	70	70	QRC-IA-51-F-NF32-VT-W5	350	QRC-IA-51-M-NF32-V-W5	117,80
	4,01	2,56	5,79	3,54		2,24	2,75	2,75		771,62		259,70

Note: The connection of the two halves of a coupling is achieved depending on the type. It is important to observe the positive engagement of plug-type couplings and the secure tightening of screw-type couplings to the limit stop of the thread. Forced or improper separation will result in malfunction of the coupling.

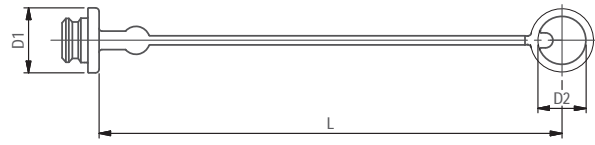
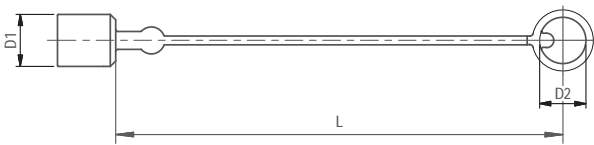

Series IA - Dust Protection

Dimensions (mm/in)			Material	Dust Cap for Male Tip
D1	D2	L		Ordering Codes
11	6	110	Plastic (Colour: Red)	QRC-IA-06-DM-19-KI-RD
.43	.24	4.33		
24	22	220	Plastic (Colour: Red)	QRC-IA-10-DM-22-KI-RD
.93	.87	8.66		
29	26	250	Plastic (Colour: Red)	QRC-IA-12-DM-26-KI-RD
1.14	1.02	9.84		
36.5	36	270	Plastic (Colour: Red)	QRC-IA-19-DM-36-KI-RD
1.44	1.42	10.63		
36	28	235	Plastic (Colour: Red)	QRC-IA-25-DM-28-KI-RD
1.42	1.10	9.25		

Dimensions (mm/in)			Material	Dust Plug for Female Body
D1	D2	L		Ordering Codes
10	6	110	Plastic (Colour: Red)	QRC-IA-06-DF-19-KI-RD
.39	.24	4.33		
28	22	220	Plastic (Colour: Red)	QRC-IA-10-DF-22-KI-RD
1.10	.87	8.66		
35	26	250	Plastic (Colour: Red)	QRC-IA-12-DF-26-KI-RD
1.38	1.02	9.84		
42	36	270	Plastic (Colour: Red)	QRC-IA-19-DF-36-KI-RD
1.65	1.42	10.63		
41	28	235	Plastic (Colour: Red)	QRC-IA-25-DF-28-KI-RD
1.61	1.10	9.25		

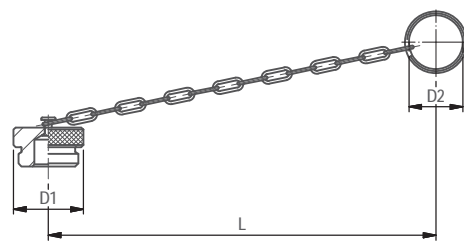
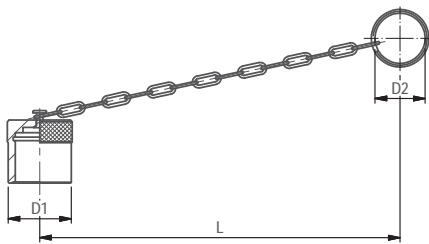
IA

Dimensions (mm/in)			Material	Dust Cap for Male Tip
D1	D2	L		Ordering Codes
19	30	180	Aluminium with chain	QRC-IA-06-DM-30/CN-W89-SI
.75	1.18	7.09		
30	33	200	Aluminium with chain	QRC-IA-10-DM-33/CN-W89-SI
1.18	1.30	7.87		
38	32	205	Aluminium with chain	QRC-IA-12-DM-32/CN-W89-SI
1.50	1.26	8.07		
45	47	275	Aluminium with chain	QRC-IA-19-DM-47/CN-W89-SI
1.77	1.85	10.83		
45	41	290	Aluminium with chain	QRC-IA-25-DM-41/CN-W89-SI
1.77	1.61	11.42		
70	47	275	Aluminium with chain	QRC-IA-31-DM-47/CN-W89-SI
2.76	1.85	10.83		

Dimensions (mm/in)			Material	Dust Plug for Female Body
D1	D2	L		Ordering Codes
19	30	160	Aluminium with chain	QRC-IA-06-DF-30/CN-W89-SI
.75	1.18	6.30		
30	33	200	Aluminium with chain	QRC-IA-10-DF-33/CN-W89-SI
1.18	1.30	7.87		
38	32	205	Aluminium with chain	QRC-IA-12-DF-32/CN-W89-SI
1.50	1.26	8.07		
45	47	275	Aluminium with chain	QRC-IA-19-DF-47/CN-W89-SI
1.77	1.85	10.83		
43	41	240	Aluminium with chain	QRC-IA-25-DF-41/CN-W89-SI
1.69	1.61	9.45		
70	47	275	Aluminium with chain	QRC-IA-31-DF-47/CN-W89-SI
2.76	1.85	10.83		

In addition to the standard colours as stated above, plastic dust caps are also available in blue, green, yellow and black. Please use the color codes BU, GN, YE and BK respectively instead of RD.



IA

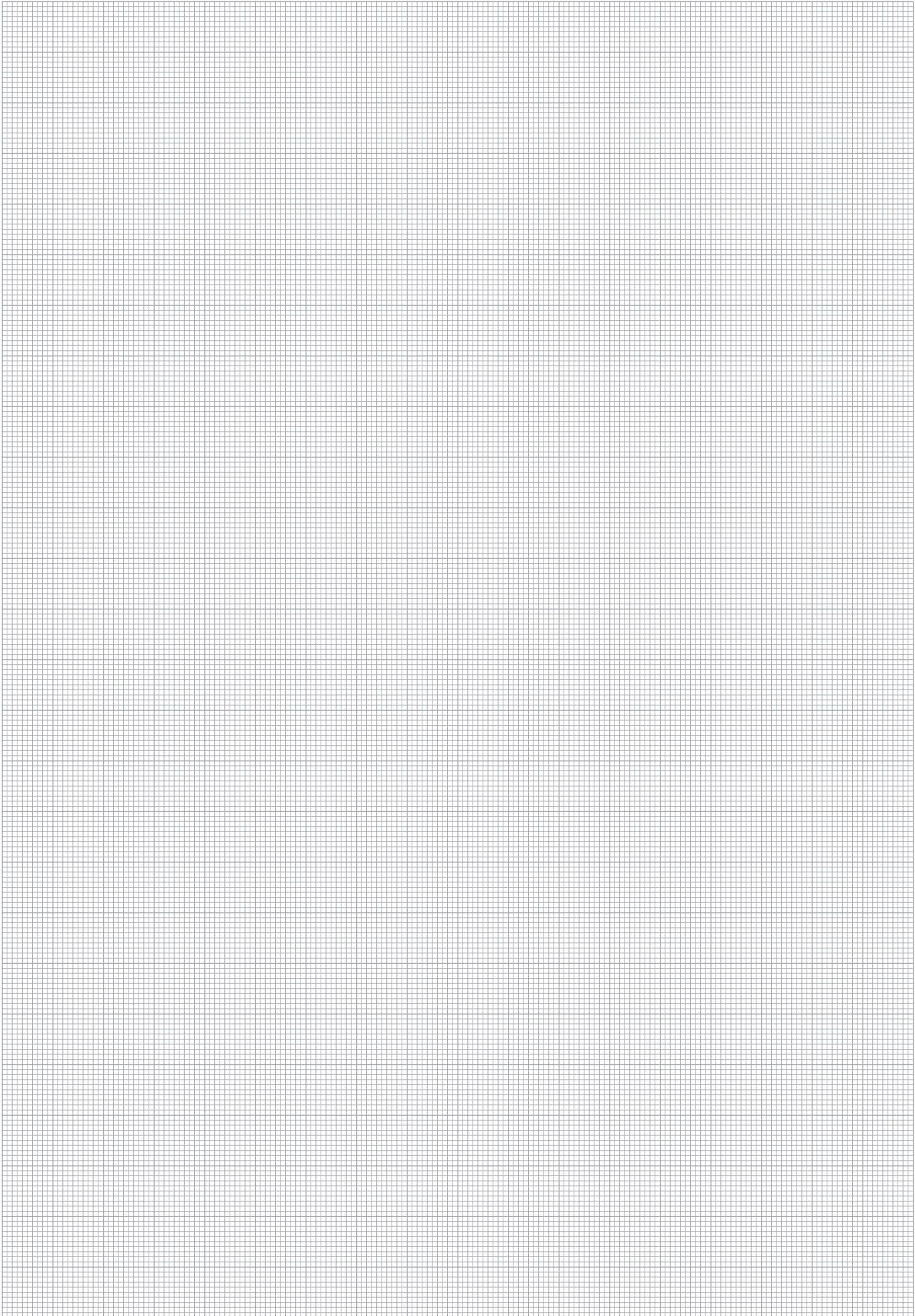

Series IB • Carbon Steel
Product Description

Push-to-Connect couplings of the IB Series from STAUFF consist of a male tip and a female body which are used for quick and easy connection (push) and disconnection of tubes, pipes and hoses by hand, i.e. without tools.

The Series was developed according to ISO 7241-1 B in the following nominal sizes 05, 06, 10, 12, 19, 25, 31, 38, 51 (1/8" - 2").

The proven design is suitable for use in industrial Hydraulic. Other applications may, depending on the pressure and flow characteristics, include construction equipment, oil tools, oil equipment steel mill machinery, and other demanding industrial hydraulic applications.

Features

- poppet valve
- Coupling made from carbon steel with Zinc/Nickel surface coating
- Integrated locking system preventing unintentional release of the coupling
- ISO Interchange acc. to ISO 7241-1 Series B

Applications

Industrial Hydraulic
Top Features

Zinc/Nickel coating

Designed for secure connection
IB

Series IB • Carbon Steel

Material	Carbon Steel
Surface Finishing	Zinc-Nickel
Standard Seal Material(s)	NBR (Buna-N®) ²
Working Temperature	-25° C ... +100° C / -13° F ... +212° F
Valve Design	Poppet Valve
Connection	Push and actuate Push Sleeve
Disconnection	Actuate Push Sleeve
Connect Under Pressure	not allowed
Application	Industrial Hydraulic
ISO Interchange	ISO 7241-1, Series B



² Alternative seal materials are available on request.

Technical Data

Series	BG	DN Zoll	DN metric ISO 4397	Q _{max}		Working Pressure		Bursting Pressure Connected		Female Body		Male Tip		Spillage	
				l/min	US GPM	bar	PSI	bar	PSI	bar	PSI	bar	PSI	ml	fl oz
IB-05	0	1/8"	3	4,5	1.19	300	4351	2000	29008	2300	33359	2400	34809	0,5	.0169
IB-06	1	1/4"	6,3	18	4.76	250	3626	1250	18130	1250	18130	1250	18130	1	.0338
IB-10	2	3/8"	10	34,5	9.11	250	3626	1250	18130	1250	18130	1250	18130	2,4	.0812
IB-12	3	1/2"	12,5	67,5	17.83	250	3626	1250	18130	1250	18130	1250	18130	3,9	.1319
IB-19	4	3/4"	19 (20)	159	42.00	250	3626	1000	14504	1000	14504	1000	14504	11	.3720
IB-25	6	1"	25	378	99.86	200	2901	1000	14504	1000	14504	1000	14504	19	.6425
IB-38	8	1 1/2"	38	562	148.47	75	1088	300	4351	300	4351	300	4351	95	32.123
IB-51	9	2"	51	840	221.91	63	914	500	7252	500	7252	500	7252	170	57.484

The indicated pressure ratings only apply to the coupling itself and depend on the connection type. Up to DN 25 acc. to ISO 7241-1, Series B

Flow Characteristics

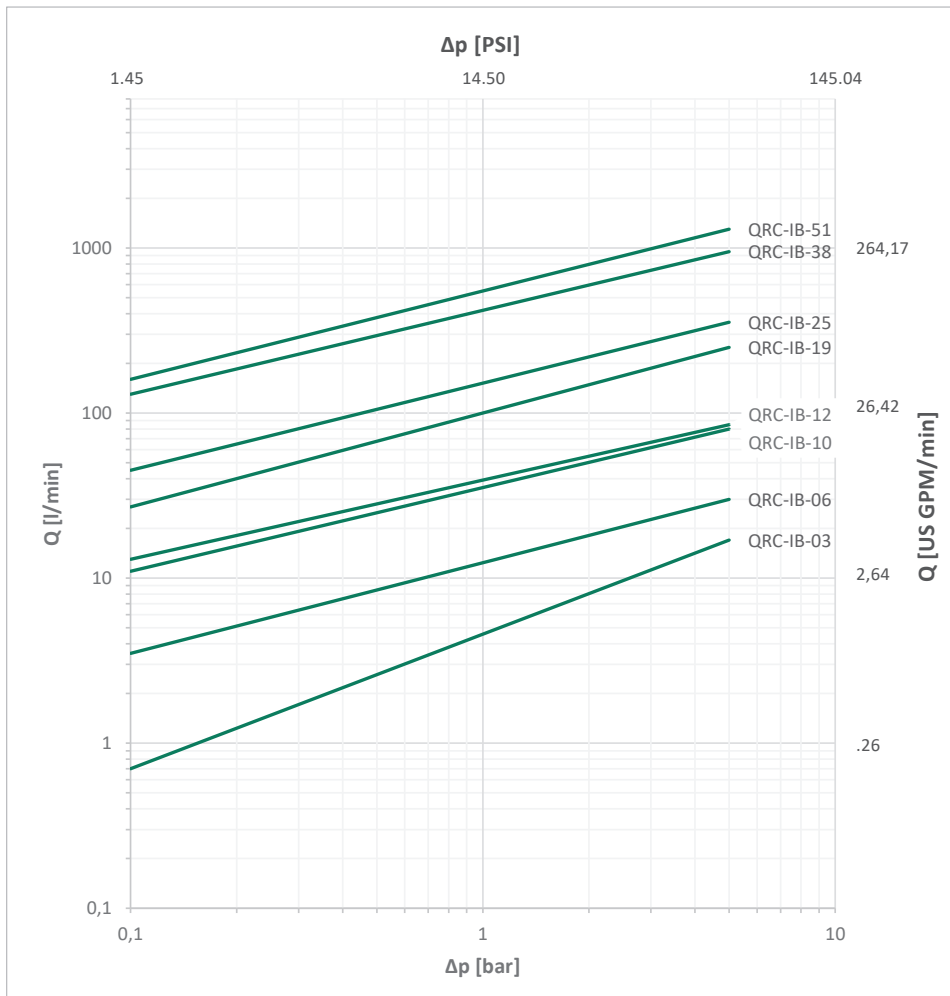

Please note: Unless otherwise stated, all flow characteristics have been determined with hydraulic oil with a kinematic viscosity of 28,8 - 35,2 mm²/s (28,8 - 35,2 cSt) and are only valid for components with non-reducing connections.



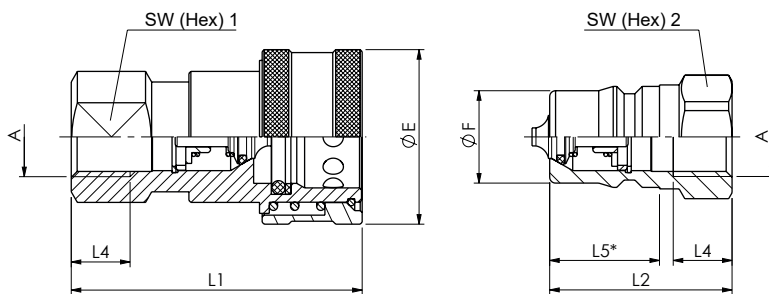

SW: Width across flats. All dimensions in mm (inch). Drawing similar Series IB-12.
* Insertion Male Tip.

Series IB-05 • BG 0 • Nominal Size 3,2

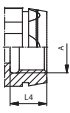
Port A	Dimensions (mm/in)								Female Body Ordering Codes	Weight (kg/lbs) ca. per 100	Male Tip Ordering Codes	Weight (kg/lbs) ca. per 100
	ØE	ØF	L1	L2	L4 min	L5	SW1	SW2				
Female Thread according to ANSI B 1.20.3												
	NPTF 1/8" -27	24	10,9	48	29		17	14	QRC-IB-03-F-NF02-BT-W3	8,90	QRC-IB-03-M-NF02-B-W3	2
		.94	.43	1.89	1.14		.67	.55		19.62		4.41

Series IB-06 • BG 1 • Nominal Size 6,3

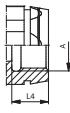
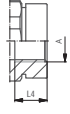
Port A	Dimensions (mm/in)								Female Body Ordering Codes	Weight (kg/lbs) ca. per 100	Male Tip Ordering Codes	Weight (kg/lbs) ca. per 100	
	ØE	ØF	L1	L2	L4 min	L5	SW1	SW2					
Female Thread according to DIN 3852 - ISO 1179-1 - ANSI B 1.20.3													
	G 1/4"	28,5	14,2	58	36	13	21,5	19	19	QRC-IB-06-F-G04-BT-W3	13,5	QRC-IB-06-M-G04-B-W3	3,81
		1.12	.56	2.28	1.42	.51	.85	.75	.75		29.76		8.40
	NPTF 1/4" -18	28,5	14,2	58	36		21,5	19	19	QRC-IB-06-F-NF04-BT-W3	13,51	QRC-IB-06-M-NF04-B-W3	3,82
		1.12	.56	2.28	1.42		.85	.75	.75		29.78		8.42
Female Thread according to SAE J 1926-1													
	UNF 9/16" -18	28,5	14,2	58	36	13	21,8	19	19	QRC-IB-06-F-U06-BT-W3	12,60	QRC-IB-06-M-U06-B-W3	3,56
		1.12	.56	2.28	1.42	.51	.86	.75	.75		27.78		7.85

Series IB-10 • BG 2 • Nominal Size 10

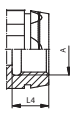
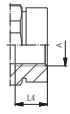
Port A	Dimensions (mm/in)								Female Body Ordering Codes	Weight (kg/lbs) ca. per 100	Male Tip Ordering Codes	Weight (kg/lbs) ca. per 100	
	ØE	ØF	L1	L2	L4 min	L5	SW1	SW2					
Female Thread according to DIN 3852 - ISO 1179-1 - ANSI B 1.20.3													
	G 3/8"	35	19,1	65	40	13	24,2	24	24	QRC-IB-10-F-G06-BT-W3	22,59	QRC-IB-10-M-G06-B-W3	6,82
		1.38	.75	2.56	1.57	.51	.95	.94	.94		49.80		15.04
	NPTF 3/8" -18	35	19,1	65	40		24,2	24	24	QRC-IB-10-F-NF06-BT-W3	22,51	QRC-IB-10-M-NF06-B-W3	6,81
		1.38	.75	2.56	1.57		.95	.94	.94		49.63		15.01
Female Thread according to SAE J 1926-1													
	UNF 3/4" -16	35	19,1	65	40	14,3	24,7	24	24	QRC-IB-10-F-U08-BT-W3	22,30	QRC-IB-10-M-U08-B-W3	6,67
		1.38	.75	2.56	1.57	.56	.97	.94	.94		49.16		14.70



Note: The connection of the two halves of a coupling is achieved depending on the type. It is important to observe the positive engagement of plug-type couplings and the secure tightening of screw-type couplings to the limit stop of the thread. Forced or improper separation will result in malfunction of the coupling.

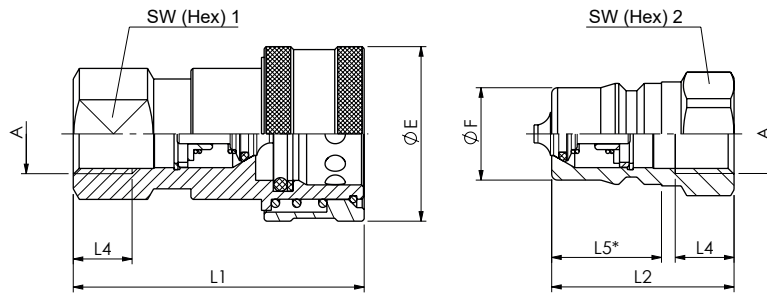



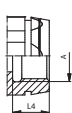

SW: Width across flats. All dimensions in mm (inch). Drawing similar Series IB-12.
* Insertion Male Tip.

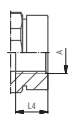

Series IB-12 • BG 3 • Nominal Size 12,5

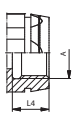
Port A	Dimensions (mm/in)								Female Body Ordering Codes	Weight (kg/lbs) ca. per 100	Male Tip Ordering Codes	Weight (kg/lbs) ca. per 100
	ØE	ØF	L1	L2	L4 min	L5	SW1	SW2				
Female Thread according to DIN 3852 - ISO 1179-1 - ANSI B 1.20.3												
 G 1/2"	44,5	23,55	74	46,5	15	27,2	28,5	28,5	QRC-IB-12-F-G08-BT-W3	38,86	QRC-IB-12-M-G08-B-W3	12,36
	1,75	.93	2,91	1,83	.59	1,07	1,12	1,12		85,67		27,25
 NPTF 1/2" -14	44,5	23,55	74	46,5		27,2	28,5	28,5	QRC-IB-12-F-NF08-BT-W3	38,56	QRC-IB-12-M-NF08-B-W3	12,07
	1,75	.93	2,91	1,83		1,07	1,12	1,12		85,01		26,61
Female Thread according to SAE J 1926-1												
 UNF 7/8" -14	44,5	23,55	74	46,5	16,7	27,2	28,5	28,5	QRC-IB-12-F-U10-BT-W3	36,40	QRC-IB-12-M-U10-B-W3	12,3
	1,75	.93	2,91	1,83	.66	1,07	1,12	1,12		80,25		27,12

Series IB-19 • BG 4 • Nominal Size 19

Port A	Dimensions (mm/in)								Female Body Ordering Codes	Weight (kg/lbs) ca. per 100	Male Tip Ordering Codes	Weight (kg/lbs) ca. per 100
	ØE	ØF	L1	L2	L4 min	L5	SW1	SW2				
Female Thread according to DIN 3852 - ISO 1179-1 - ANSI B.1.20.3												
 G 3/4"	54	31,5	92	56	16	34	36	36	QRC-IB-19-F-G12-BT-W3	66,56	QRC-IB-19-M-G12-B-W3	22,3
	2,13	1,24	3,62	2,20	.63	1,34	1,42	1,42		146,74		49,16
 NPTF 3/4" -14	54	31,5	92	56		34	36	36	QRC-IB-19-F-NF12-BT-W3	65,88	QRC-IB-19-M-NF12-B-W3	21,66
	2,13	1,24	3,62	2,20		1,34	1,42	1,42		145,24		47,75

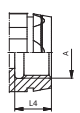
Series IB-25 • BG 6 • Nominal Size 25

Port A	Dimensions (mm/in)								Female Body Ordering Codes	Weight (kg/lbs) ca. per 100	Male Tip Ordering Codes	Weight (kg/lbs) ca. per 100
	ØE	ØF	L1	L2	L4 min	L5	SW1	SW2				
Female Thread according to DIN 3852 - ISO 1179-1 - ANSI B.1.20.3												
 G 1"	63,5	37,8	103	63	21	39,3	41	41	QRC-IB-25-F-G16-BT-W3	101,57	QRC-IB-25-M-G16-B-W3	33,77
	2,50	1,49	4,06	2,48	.83	1,55	1,61	1,61		223,92		74,45
 NPTF 1" -11 1/2	63,5	37,8	103	63		39,3	41	41	QRC-IB-25-F-NF16-BT-W3	102,5	QRC-IB-25-M-NF16-B-W3	34,71
	2,50	1,49	4,06	2,48		1,55	1,61	1,61		225,97		76,52

Note: The connection of the two halves of a coupling is achieved depending on the type. It is important to observe the positive engagement of plug-type couplings and the secure tightening of screw-type couplings to the limit stop of the thread. Forced or improper separation will result in malfunction of the coupling.



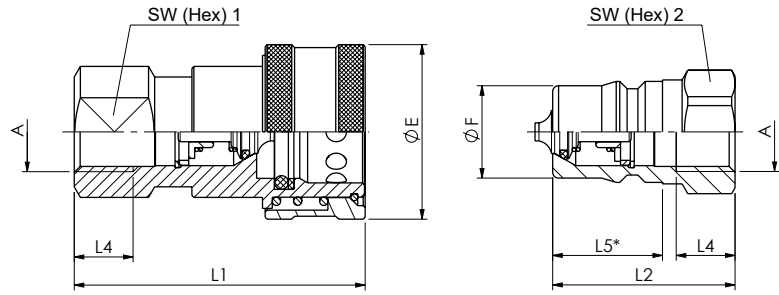

SW: Width across flats. All dimensions in mm (inch). Drawing similar Series IB-12.
* Insertion Male Tip.

Series IB-38 • BG 8 • Nominal Size 38

Port A	Dimensions (^{mm} / _{in})								Female Body Ordering Codes	Weight (^{kg} / _{lbs}) ca. per 100	Male Tip Ordering Codes	Weight (^{kg} / _{lbs}) ca. per 100
	ØE	ØF	L1	L2	L4 min	L5	SW1	SW2				
Female Thread according to DIN 3852 - ISO 1179-1 - ANSI B.1.20.3												
 G 1 1/4"	73,5	44,5	124	122	23,8	52	65	65	QRC-IB-38-F-G20-BT-W3	191,58	QRC-IB-38-M-G20-B-W3	127,51
	2,89	1,75	4,88	4,80	.94	2,05	2,56	2,56		422,36		281,11
 NPTF 1 1/4" -11 1/2	73,5	44,5	124	122		52	65	65	QRC-IB-38-F-NF20-BT-W3	193,51	QRC-IB-38-M-NF20-B-W3	129,41
	2,89	1,75	4,88	4,80		2,05	2,56	2,56		426,62		285,30

Series IB-51 • BG 9 • Nominal Size 51

Port A	Dimensions (^{mm} / _{in})								Female Body Ordering Codes	Weight (^{kg} / _{lbs}) ca. per 100	Male Tip Ordering Codes	Weight (^{kg} / _{lbs}) ca. per 100
	ØE	ØF	L1	L2	L4 min	L5	SW1	SW2				
Female Thread according to DIN 3852 - ISO 1179-1 - ANSI B.1.20.3												
 G 2"	101	63,2	141,5	139,2	30,5	63	95	95	QRC-IB-51-F-G32-BT-W3	521,99	QRC-IB-51-M-G32-B-W3	361,76
	3,98	2,49	5,57	5,48	1,20	2,48	3,74	3,74		1150,79		797,54
 NPTF 2" -11 1/2	101	63,2	141,5	139,2		63	95	95	QRC-IB-51-F-NF32-BT-W3	531,99	QRC-IB-51-M-NF32-B-W3	371,75
	3,98	2,49	5,57	5,48		2,48	3,74	3,74		1172,84		819,57

IB

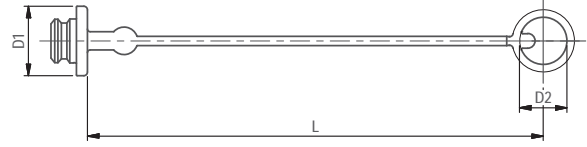
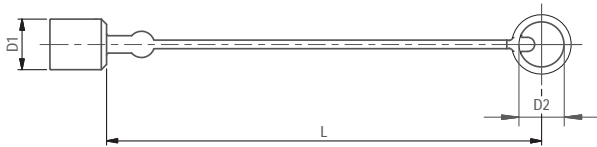

Series IB - Dust Protection



Dimensions (mm/in)			Material	Dust Cap for Male Tip
D1	D2	L		Ordering Codes
18	23	240	Plastic (Colour: Red)	QRC-IB-06-DM-23-KI-RD
.71	.91	9.45		
23	24	240	Plastic (Colour: Red)	QRC-IB-10-DM-24-KI-RD
.91	.94	9.45		
29	28	245	Plastic (Colour: Red)	QRC-IB-12-DM-28-KI-RD
1.14	1.10	9.65		
36,0	38	245	Plastic (Colour: Red)	QRC-IB-19-DM-38-KI-RD
1.42	1.50	9.65		
44	46	253	Plastic (Colour: Red)	QRC-IB-25-DM-46-KI-RD
1.73	1.81	9.96		

Dimensions (mm/in)			Material	Dust Plug for Female Body
D1	D2	L		Ordering Codes
26	23	240	Plastic (Colour: Red)	QRC-IB-06-DF-23-KI-RD
1.02	.91	9.45		
33	24	235	Plastic (Colour: Red)	QRC-IB-10-DF-24-KI-RD
1.30	.94	9.25		
38	28	240	Plastic (Colour: Red)	QRC-IB-12-DF-28-KI-RD
1.50	1.10	9.45		
49	38	240	Plastic (Colour: Red)	QRC-IB-19-DF-38-KI-RD
1.93	1.50	9.45		
60	46	245	Plastic (Colour: Red)	QRC-IB-25-DF-46-KI-RD
2.36	1.81	9.65		

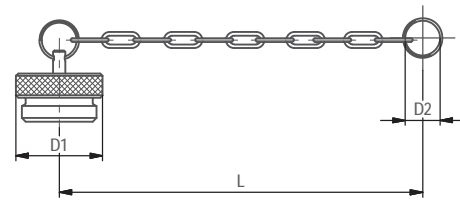
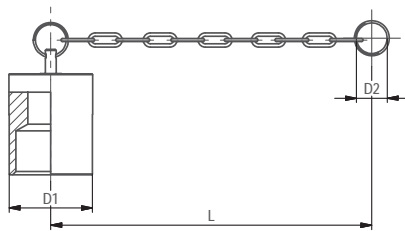
IB



Dimensions (mm/in)			Material	Dust Cap for Male Tip
D1	D2	L		Ordering Codes
22	22	245	Aluminium with chain	QRC-IB-06-DM-28/CN-W89-SI
.87	.87	9.65		
27	30	155	Aluminium with chain	QRC-IB-10-DM-30/CN-W89-SI
1.06	1.18	6.10		
35	41	265	Aluminium with chain	QRC-IB-12-DM-41/CN-W89-SI
1.38	1.61	10.43		
42	30	250	Aluminium with chain	QRC-IB-19-DM-30/CN-W89-SI
1.65	1.18	9.84		
48	49	340	Aluminium with chain	QRC-IB-25-DM-49/CN-W89-SI
1.89	1.93	13.39		
55	46	225	Aluminium with chain	QRC-IB-38-DM-46/CN-W89-SI
2.17	1.81	8.86		
80	75	350	Aluminium with chain	QRC-IB-51-DM-75/CN-W89-SI
3.15	2.95	13.78		

Dimensions (mm/in)			Material	Dust Plug for Female Body
D1	D2	L		Ordering Codes
22	22	210	Aluminium with chain	QRC-IB-06-DF-30/CN-W89-SI
.87	.87	8.27		
22	30	155	Aluminium with chain	QRC-IB-10-DF-30/CN-W89-SI
.87	1.18	6.10		
28	41	305	Aluminium with chain	QRC-IB-12-DF-41/CN-W89-SI
1.10	1.61	12.01		
35	43	265	Aluminium with chain	QRC-IB-19-DF-43/CN-W89-SI
1.38	1.69	10.43		
44	41	240	Aluminium with chain	QRC-IB-25-DF-41/CN-W89-SI
1.73	1.61	9.45		
74	46	225	Aluminium with chain	QRC-IB-38-DF-46/CN-W89-SI
2.91	1.81	8.86		
105	75	350	Aluminium with chain	QRC-IB-51-DF-75/CN-W89-SI
4.13	2.95	13.78		

In addition to the standard colours as stated above, plastic dust caps are also available in blue, green, yellow and black. Please use the color codes BU, GN, YE and BK respectively instead of RD.



Product Description

Push-to-Connect couplings of the IB Series made of brass from STAUFF consist of a male tip and a female body which are used for quick and easy connection (push) and disconnection of tubes, pipes and hoses by hand, i.e. without tools.

The Series was developed according to ISO 7241-1 B in the following nominal sizes 06, 10, 12, 19, 25, 38, 51 (1/4" - 2").

Features

- poppet valve
- Coupling made of brass
- Integrated locking system preventing unintentional release of the coupling
- ISO Interchange acc. to ISO 7241-1 Series B

Applications



Industrial Hydraulic

Top Features



Designed for secure connection

The proven design is suitable for use in industrial Hydraulic. Other applications may, depending on the pressure and flow characteristics, include construction equipment, oil tools, oil equipment steel mill machinery, and other demanding industrial hydraulic applications.



Series IB • Brass

Material	Brass
Surface Finishing	-
Standard Seal Material(s)	FKM (Viton®) ²
Working Temperature	-25° C ... +200° C / -13° F ... +392° F
Valve Design	Poppet Valve
Connection	Push and actuate Push Sleeve
Disconnection	Actuate Push Sleeve
Connect Under Pressure	not allowed
Application	Industrial Hydraulic
ISO Interchange	Up to DN 25 according to ISO 7241-1, Series B



² Alternative seal materials are available on request.

Technical Data

Series	BG	DN Zoll Inch	DN metric ISO 4397	Q _{max}		Working Pressure		Bursting Pressure Connected		Female Body		Male Tip		Spillage	
				l/min	US GPM	bar	PSI	bar	PSI	bar	PSI	bar	PSI	ml	fl oz
IB-06	1	1/4"	6,3	18	4.76	160	2321	640	9282	600	8702	600	8702	1	.0338
IB-10	2	3/8"	10	34,5	9.11	160	2321	640	9282	640	9282	640	9282	2,4	.0812
IB-12	3	1/2"	12,5	67,5	17.83	160	2321	640	9282	640	9282	600	8702	3,9	.1319
IB-19	4	3/4"	19 (20)	159	42.00	125	1813	500	7252	500	7252	500	7252	11	.3720
IB-25	6	1"	25	283	74.76	100	1450	400	5802	400	5802	400	5802	19	.6425
IB-38	8	1 1/2"	38	513	135.52	63	914	250	3626	250	3626	250	3626	95	3.32
IB-51	9	2"	51	788	208.17	50	725	200	2901	200	2901	200	2901	170	5.95

The indicated pressure ratings only apply to the coupling itself and depend on the connection type.

Flow Characteristics

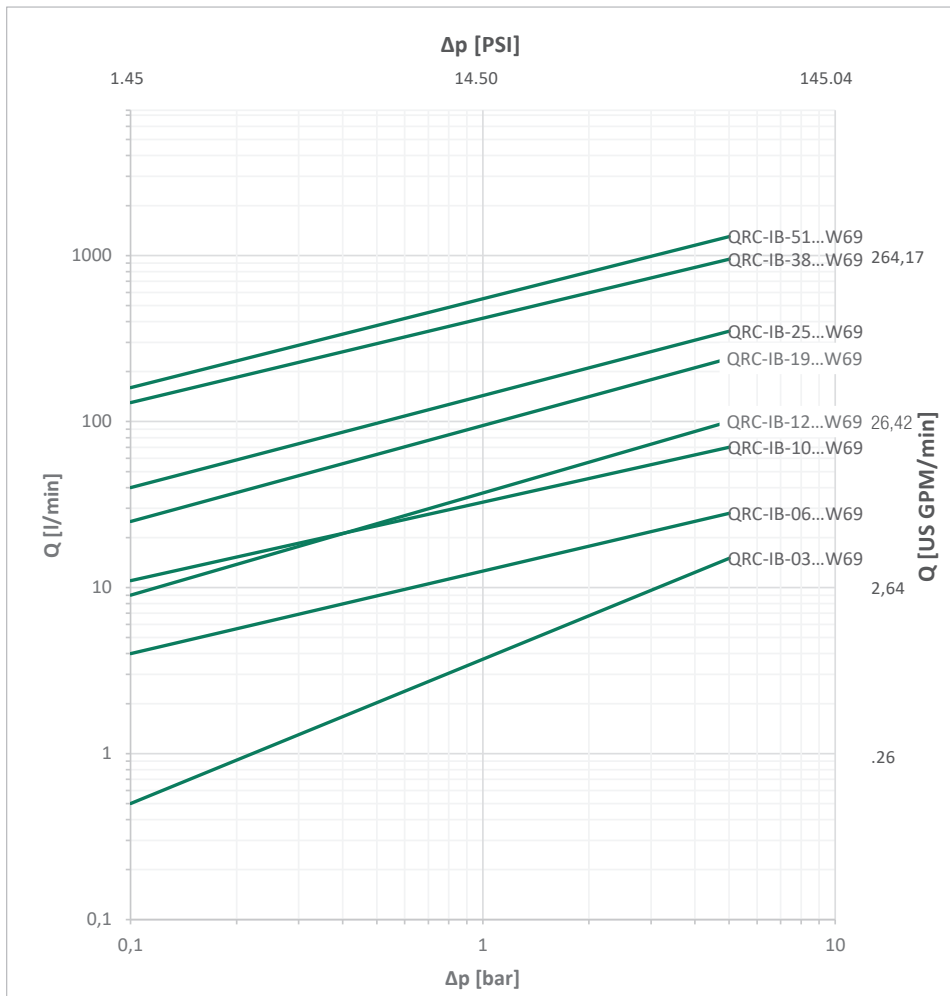

Please note: Unless otherwise stated, all flow characteristics have been determined with hydraulic oil with a kinematic viscosity of 28,8 - 35,2 mm²/s (28,8 - 35,2 cSt) and are only valid for components with non-reducing connections.



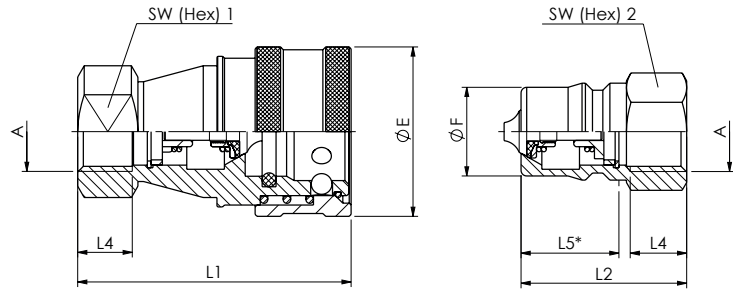

SW: Width across flats. All dimensions in mm (inch). Drawing similar Series IB-12.
* Insertion Male Tip.

Series IB-06 ▪ BG 1 ▪ Nominal Size 6,3

Port A	Dimensions (^{mm} / _{in})								Female Body Ordering Codes	Weight (^{kg} / _{lbs}) ca. per 100	Male Tip Ordering Codes	Weight (^{kg} / _{lbs}) ca. per 100	
	ØE	ØF	L1	L2	L4	L5	SW1	SW2					
Female Thread according to DIN 3852 - ISO 1179-1 - ANSI B 1.20.3													
	G 1/4"	28,5	14,2	58	36	13	21,5	19	19	QRC-IB-06-F-G04-VT-W69	14,45	QRC-IB-06-M-G04-V-W69	3,28
		1.12	.56	2.28	1.42	.51	.85	.75	.75		31.86		7.23
	NPTF 1/4" -18	28,5	14,2	58	36		21,5	19	19	QRC-IB-06-F-NF04-VT-W69	14,55	QRC-IB-06-M-NF04-V-W69	3,38
		1.12	.56	2.28	1.42		.85	.75	.75		32.08		7.45

Series IB-10 ▪ BG 2 ▪ Nominal Size 10

Port A	Dimensions (^{mm} / _{in})								Female Body Ordering Codes	Weight (^{kg} / _{lbs}) ca. per 100	Male Tip Ordering Codes	Weight (^{kg} / _{lbs}) ca. per 100	
	ØE	ØF	L1	L2	L4	L5	SW1	SW2					
Female Thread according to DIN 3852 - ISO 1179-1 - ANSI B 1.20.3													
	G 3/8"	35	19,1	65	40	13	28,2	24	22	QRC-IB-10-F-G06-VT-W69	22,46	QRC-IB-10-M-G06-V-W69	7,11
		1.38	.75	2.56	1.57	.51	1.11	.94	.87		49.52		15.67
	NPTF 3/8" -18	35	19,1	65	40		28,2	24	22	QRC-IB-10-F-NF06-VT-W69	22,65	QRC-IB-10-M-NF06-V-W69	7,21
		1.38	.75	2.56	1.57		1.11	.94	.87		49.93		15.90

Series IB-12 ▪ BG 3 ▪ Nominal Size 12,5

Port A	Dimensions (^{mm} / _{in})								Female Body Ordering Codes	Weight (^{kg} / _{lbs}) ca. per 100	Male Tip Ordering Codes	Weight (^{kg} / _{lbs}) ca. per 100	
	ØE	ØF	L1	L2	L4	L5	SW1	SW2					
Female Thread according to DIN 3852 - ISO 1179-1 - ANSI B 1.20.3													
	G 1/2"	45	23,55	72,6	44	14,5	27,2	29	27	QRC-IB-12-F-G08-VT-W69	45,33	QRC-IB-12-M-G08-V-W69	11,16
		1.77	.93	2.86	1.73	.57	1.07	1.14	1.06		99.94		24.60
	NPTF 1/2" -14	45	23,55	72,6	44		27,2	29	27	QRC-IB-12-F-NF08-VT-W69	45,72	QRC-IB-12-M-NF08-V-W69	11,54
		1.77	.93	2.86	1.73		1.07	1.14	1.06		100.80		25.44

Series IB-19 ▪ BG 4 ▪ Nominal Size 19

Port A	Dimensions (^{mm} / _{in})								Female Body Ordering Codes	Weight (^{kg} / _{lbs}) ca. per 100	Male Tip Ordering Codes	Weight (^{kg} / _{lbs}) ca. per 100	
	ØE	ØF	L1	L2	L4	L5	SW1	SW2					
Female Thread according to DIN 3852 - ISO 1179-1 - ANSI B 1.20.3													
	G 3/4"	54	31,5	88,2	52	16	34	36	36	QRC-IB-19-F-G12-VT-W69	71,75	QRC-IB-19-M-G12-V-W69	23,19
		2.13	1.24	3.47	2.05	.63	1.34	1.42	1.42		158.18		51.13
	NPTF 3/4" -14	54	31,5	88,2	52		34	36	36	QRC-IB-19-F-NF12-VT-W69	72,11	QRC-IB-19-M-NF12-V-W69	23,58
		2.13	1.24	3.47	2.05		1.34	1.42	1.42		158.98		51.99

Note: The connection of the two halves of a coupling is achieved depending on the type. It is important to observe the positive engagement of plug-type couplings and the secure tightening of screw-type couplings to the limit stop of the thread. Forced or improper separation will result in malfunction of the coupling.



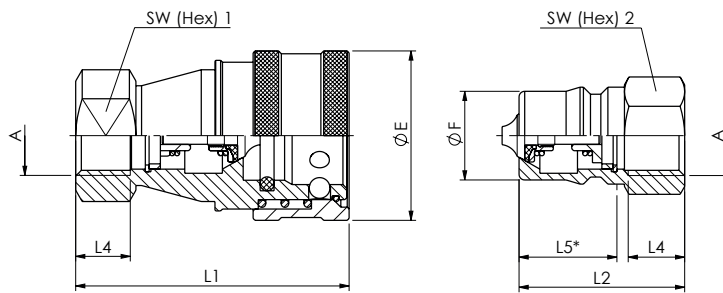

SW: Width across flats. All dimensions in mm (inch). Drawing similar Series IB-12.
* Insertion Male Tip.

Series IB-25 ▪ BG 6 ▪ Nominal Size 25

Port A	Dimensions (mm/in)								Female Body Ordering Codes	Weight (^{kg} /lbs) ca. per 100	Male Tip Ordering Codes	Weight (^{kg} /lbs) ca. per 100
	ØE	ØF	L1	L2	L4 min	L5	SW1	SW2				
Female Thread according to DIN 3852 - ISO 1179-1 - ANSI B 1.20.3												
 G 1"	65	37,8	102	62	20	39,3	41	40	QRC-IB-25-F-G16-VT-W69	108,96	QRC-IB-25-M-G16-V-W69	36,43
	2.56	1.49	4.02	2.44	.79	1.55	1.61	1.57		240.22		80.31
 NPTF 1" -11 1/2	65	37,8	102	62		39,3	41	40	QRC-IB-25-F-NF16-VT-W69	109,16	QRC-IB-25-M-NF16-V-W69	36,62
	2.56	1.49	4.02	2.44		1.55	1.61	1.57		240.66		80.73

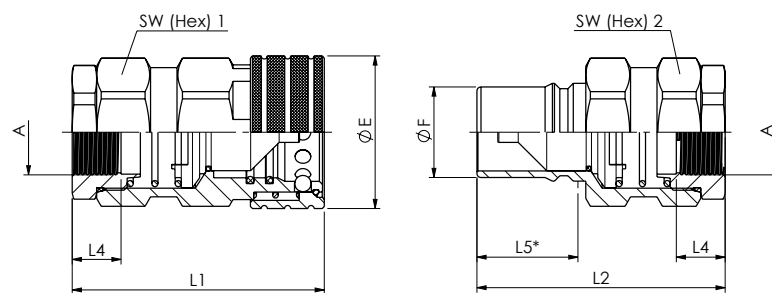

* Insertion Male Tip.

Series IB-38 ▪ BG 8 ▪ Nominal Size 38

Port A	Dimensions (mm/in)								Female Body Ordering Codes	Weight (^{kg} /lbs) ca. per 100	Male Tip Ordering Codes	Weight (^{kg} /lbs) ca. per 100
	ØE	ØF	L1	L2	L4 min	L5	SW1	SW2				
Female Thread according to DIN 3852 - ISO 1179-1 - ANSI B 1.20.3												
 G 1 1/4"	75	44,5	124	122	24	52	65	65	QRC-IB-38-F-G20-VT-W69	205,91	QRC-IB-38-M-G20-V-W69	131,33
	2.95	1.75	4.88	4.80	.94	2.05	2.56	2.56		453.95		289.53
 NPTF 1 1/4" -11 1/2	75	44,5	124	122		52	65	65	QRC-IB-38-F-NF20-VT-W69	203,9	QRC-IB-38-M-NF20-V-W69	132,35
	2.95	1.75	4.88	4.80		2.05	2.56	2.56		449.52		291.78
 G 1 1/2"	75	44,5	124	122	24	52	65	65	QRC-IB-38-F-G24-VT-W69	199,97	QRC-IB-38-M-G24-V-W69	125,18
	2.95	1.75	4.88	4.80	.94	2.05	2.56	2.56		440.86		275.97
 NPTF 1 1/2" -11 1/2	75	44,5	124	122		52	65	65	QRC-IB-38-F-NF24-VT-W69	201,11	QRC-IB-38-M-NF24-V-W69	127,1
	2.95	1.75	4.88	4.80		2.05	2.56	2.56		443.37		280.21

Series IB-51 ▪ BG 9 ▪ Nominal Size 51

Port A	Dimensions (mm/in)								Female Body Ordering Codes	Weight (^{kg} /lbs) ca. per 100	Male Tip Ordering Codes	Weight (^{kg} /lbs) ca. per 100
	ØE	ØF	L1	L2	L4 min	L5	SW1	SW2				
Female Thread according to DIN 3852 - ISO 1179-1 - ANSI B 1.20.3												
 G 2"	101	63,2	141,5	139,2	30,5	63,5	95	95	QRC-IB-51-F-G32-VT-W69	558,57	QRC-IB-51-M-G32-V-W69	387,11
	3.98	2.49	5.57	5.48	1.20	2.50	3.74	3.74		1231.44		853.43
 NPTF 2" -11 1/2	101	63,2	141,5	139,2		63,5	95	95	QRC-IB-51-F-NF32-VT-W69	558,57	QRC-IB-51-M-NF32-V-W69	387,11
	3.98	2.49	5.57	5.48		2.50	3.74	3.74		1231.44		853.43

Note: The connection of the two halves of a coupling is achieved depending on the type. It is important to observe the positive engagement of plug-type couplings and the secure tightening of screw-type couplings to the limit stop of the thread. Forced or improper separation will result in malfunction of the coupling.

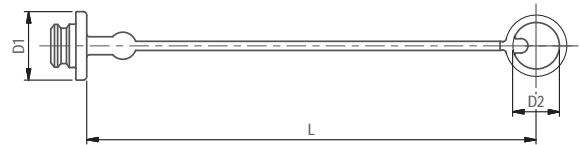
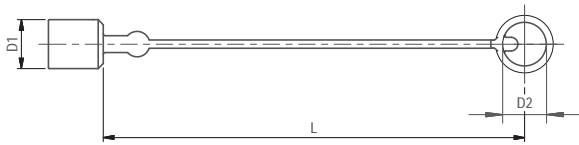

Series IB • Dust Protection

Dimensions (mm/in)			Material	Dust Cap for Male Tip
D1	D2	L		Ordering Codes
18	23	240	Plastic (Colour: Red)	QRC-IB-06-DM-23-KI-RD
.71	.91	9.45		
23	24	240	Plastic (Colour: Red)	QRC-IB-10-DM-24-KI-RD
.91	.94	9.45		
29	28	245	Plastic (Colour: Red)	QRC-IB-12-DM-28-KI-RD
1.14	1.10	9.65		
36,0	38	245	Plastic (Colour: Red)	QRC-IB-19-DM-38-KI-RD
1.42	1.50	9.65		
44	44	253	Plastic (Colour: Red)	QRC-IB-25-DM-44-KI-RD
1.73	1.73	9.96		

Dimensions (mm/in)			Material	Dust Plug for Female Body
D1	D2	L		Ordering Codes
26	23	240	Plastic (Colour: Red)	QRC-IB-06-DF-23-KI-RD
1.02	.91	9.45		
33	25	235	Plastic (Colour: Red)	QRC-IB-10-DF-25-KI-RD
1.30	.98	9.25		
38	29	240	Plastic (Colour: Red)	QRC-IB-12-DF-29-KI-RD
1.50	1.14	9.45		
49	38	240	Plastic (Colour: Red)	QRC-IB-19-DF-38-KI-RD
1.93	1.50	9.45		
60	46	245	Plastic (Colour: Red)	QRC-IB-25-DF-46-KI-RD
2.36	1.81	9.65		

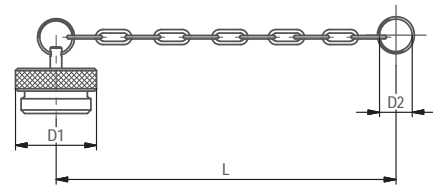
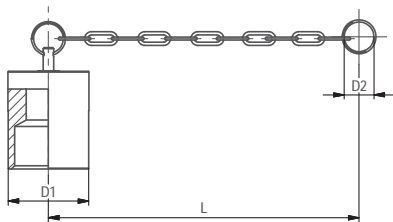

Dimensions (mm/in)			Material	Dust Cap for Male Tip
D1	D2	L		Ordering Codes
22	22	245	Aluminium with chain	QRC-IB-06-DM-28/CN-W89-SI
.87	.87	9.65		
27	30	155	Aluminium with chain	QRC-IB-10-DM-30/CN-W89-SI
1.06	1.18	6.10		
35	41	265	Aluminium with chain	QRC-IB-12-DM-41/CN-W89-SI
1.38	1.61	10.43		
42	30	250	Aluminium with chain	QRC-IB-19-DM-30/CN-W89-SI
1.65	1.18	9.84		
48	49	340	Aluminium with chain	QRC-IB-25-DM-49/CN-W89-SI
1.89	1.93	13.39		
55	46	225	Aluminium with chain	QRC-IB-38-DM-46/CN-W89-SI
2.17	1.81	8.86		
80	75	350	Aluminium with chain	QRC-IB-51-DM-75/CN-W89-SI
3.15	2.95	13.78		

Dimensions (mm/in)			Material	Dust Plug for Female Body
D1	D2	L		Ordering Codes
22	22	210	Aluminium with chain	QRC-IB-06-DF-30/CN-W89-SI
.87	.87	8.27		
22	30	155	Aluminium with chain	QRC-IB-10-DF-30/CN-W89-SI
.87	1.18	6.10		
28	41	305	Aluminium with chain	QRC-IB-12-DF-41/CN-W89-SI
1.10	1.61	12.01		
35	43	265	Aluminium with chain	QRC-IB-19-DF-43/CN-W89-SI
1.38	1.69	10.43		
44	41	240	Aluminium with chain	QRC-IB-25-DF-41/CN-W89-SI
1.73	1.61	9.45		
74	46	225	Aluminium with chain	QRC-IB-38-DF-46/CN-W89-SI
2.91	1.81	8.86		
105	75	350	Aluminium with chain	QRC-IB-51-DF-75/CN-W89-SI
4.13	2.95	13.78		

In addition to the standard colours as stated above, plastic dust caps are also available in blue, green, yellow and black. Please use the color codes BU, GN, YE and BK respectively instead of RD.

IB

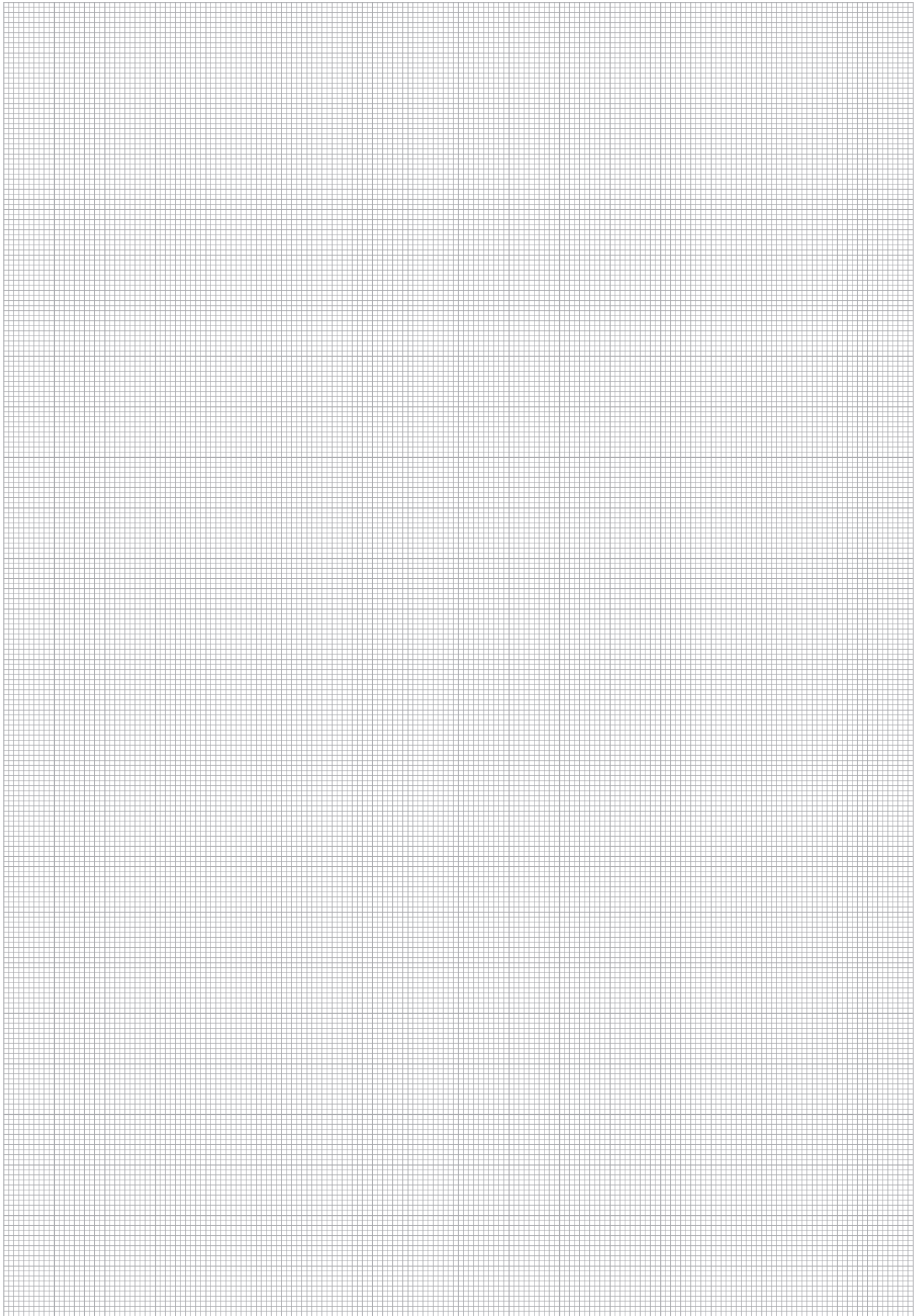
IB



Series IB • Stainless Steel
Product Description

Push-to-Connect couplings of the IB Series made of stainless steel from STAUFF consist of a male tip and a female body which are used for quick and easy connection (push) and disconnection of tubes, pipes and hoses by hand, i.e. without tools.

The Series was developed according to ISO 7241-1 B in the following nominal sizes 06, 10, 12, 19, 25, 38, 51 (1/4" - 2").

The proven design is suitable for use in industrial Hydraulic. Other applications may, depending on the pressure and flow characteristics, include construction equipment, oil tools, oil equipment steel mill machinery, and other demanding industrial hydraulic applications.

Features

- poppet valve
- Coupling made of stainless steel (AISI 316)
- Integrated locking system preventing unintentional release of the coupling
- ISO Interchange acc. to ISO 7241-1 Series B

Applications

Industrial Hydraulic

Offshore Industry
Top Features

Designed for secure connection
IB

Series IB ▪ Stainless Steel

Material	Stainless Steel V4A (AISI 316)
Surface Finishing	-
Standard Seal Material(s)	FKM (Viton®) ²
Working Temperature	-25° C ... +200° C / -13° F ... +392° F
Valve Design	Poppet Valve
Connection	Push and actuate Push Sleeve
Disconnection	Actuate Push Sleeve
Connect Under Pressure	not allowed
Application	Industrial Hydraulic
ISO Interchange	Up to DN 25 according to ISO 7241-1, Series B



² Alternative seal materials are available on request.

Technical Data

Series	BG	DN Zoll	DN metric ISO 4397	Q _{max}		Working Pressure		Bursting Pressure Connected		Female Body		Male Tip		Spillage	
				l/min	US GPM	bar	PSI	bar	PSI	bar	PSI	bar	PSI	ml	fl oz
IB-06	1	1/4"	6,3	24	6.34	350	5076	1600	23206	1500	21756	1700	24656	1	.0338
IB-10	2	3/8"	10	46	12.15	300	4351	2100	30458	1100	15954	1100	15954	2,4	.0812
IB-12	3	1/2"	12,5	90	23.78	300	4351	1500	21756	1400	20305	1500	21756	3,9	.1319
IB-19	4	3/4"	19 (20)	220	58.12	220	3191	1000	14504	900	13053	1000	14504	11	.3720
IB-25	6	1"	25	260	68.68	200	2901	850	12328	650	9427	600	8702	19	.6425
IB-38	8	1 1/2"	38	757	199.98	80	1160	250	3626	250	3626	250	3626	95	32.123
IB-51	9	2"	51	1000	264.17	60	870	200	2901	200	2901	200	2901	170	57.484

The indicated pressure ratings only apply to the coupling itself and depend on the connection type.

Flow Characteristics

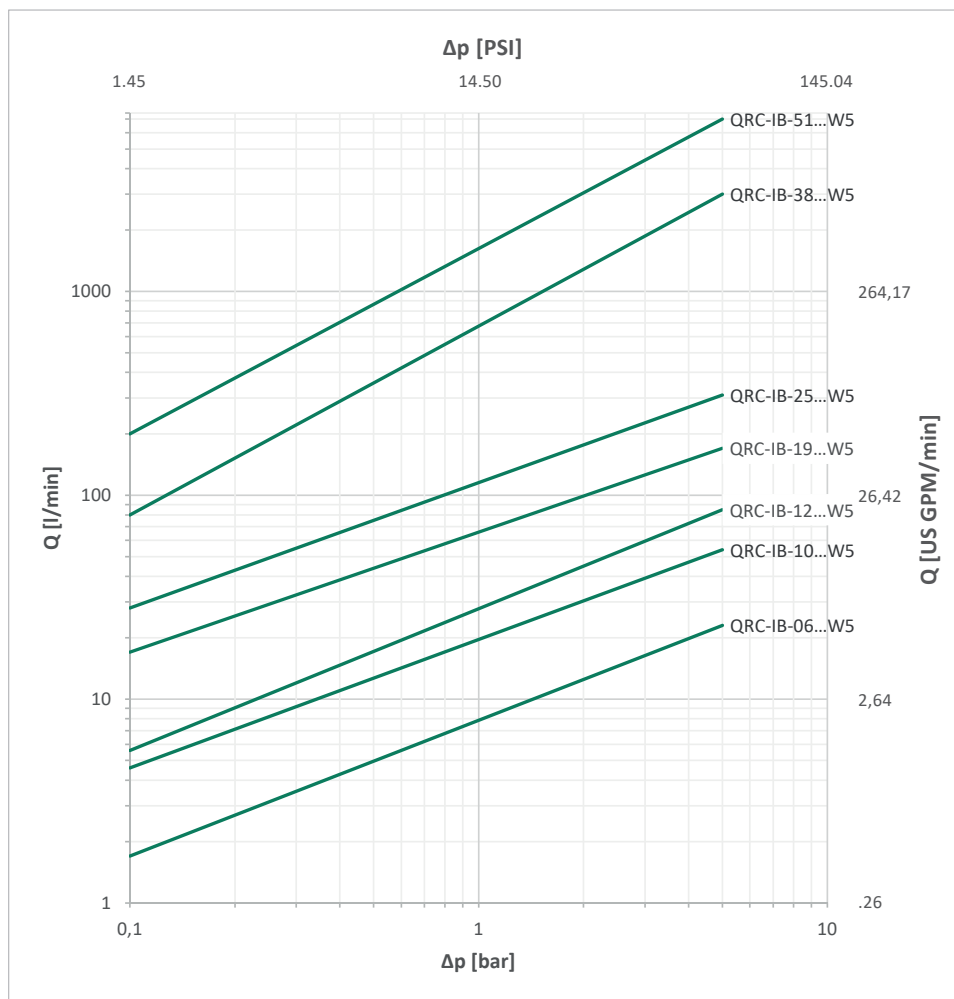

Please note: Unless otherwise stated, all flow characteristics have been determined with hydraulic oil with a kinematic viscosity of 28,8 - 35,2 mm²/s (28,8 - 35,2 cSt) and are only valid for components with non-reducing connections.



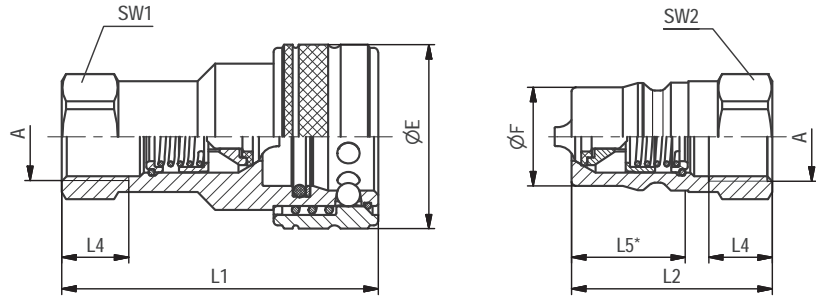

SW: Width across flats. All dimensions in mm (inch). Drawing similar Series IB-12.
* Insertion Male Tip.

Series IB-06 • BG 1 • Nominal Size 6,3

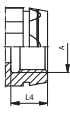
Port A	Dimensions (mm/in)								Female Body Ordering Codes	Weight (kg/lbs) ca. per 100	Male Tip Ordering Codes	Weight (kg/lbs) ca. per 100	
	ØE	ØF	L1	L2	L4 min	L5	SW1	SW2					
Female Thread according to DIN 3852 - ISO 1179-1 - ANSI B 1.20.3													
	G 1/4"	28	14,2	60	38	12	21,5	19	19	QRC-IB-06-F-G04-VT-W5	13 28.66	QRC-IB-06-M-G04-V-W5	4 8.82
	NPTF 1/4" -18	28	14,2	60	38		21,5	19	19	QRC-IB-06-F-NF04-VT-W5	13,10 28.88	QRC-IB-06-M-NF04-V-W5	4,10 9.04

Series IB-10 • BG 2 • Nominal Size 10

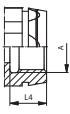
Port A	Dimensions (mm/in)								Female Body Ordering Codes	Weight (kg/lbs) ca. per 100	Male Tip Ordering Codes	Weight (kg/lbs) ca. per 100	
	ØE	ØF	L1	L2	L4 min	L5	SW1	SW2					
Female Thread according to DIN 3852 - ISO 1179-1 - ANSI B 1.20.3													
	G 3/8"	35	19,1	65,2	40,5	12	24,2	22	22	QRC-IB-10-F-G06-VT-W5	19,70 43.43	QRC-IB-10-M-G06-V-W5	6 13.23
	NPTF 3/8" -18	35	19,1	65,2	40,5		24,2	22	22	QRC-IB-10-F-NF06-VT-W5	19,80 43.65	QRC-IB-10-M-NF06-V-W5	6,10 13.45

Series IB-12 • BG 3 • Nominal Size 12,5

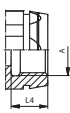
Port A	Dimensions (mm/in)								Female Body Ordering Codes	Weight (kg/lbs) ca. per 100	Male Tip Ordering Codes	Weight (kg/lbs) ca. per 100	
	ØE	ØF	L1	L2	L4 min	L5	SW1	SW2					
Female Thread according to DIN 3852 - ISO 1179-1 - ANSI B 1.20.3													
	G 1/2"	44	23,55	73,7	46	14	27,2	27	27	QRC-IB-12-F-G08-VT-W5	34,60 76.28	QRC-IB-12-M-G08-V-W5	10,70 23.59
	NPTF 1/2" -14	44	23,55	73,7	46		27,2	27	27	QRC-IB-12-F-NF08-VT-W5	35 77.16	QRC-IB-12-M-NF08-V-W5	10,90 24.03

Series IB-19 • BG 4 • Nominal Size 19

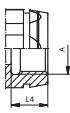
Port A	Dimensions (mm/in)								Female Body Ordering Codes	Weight (kg/lbs) ca. per 100	Male Tip Ordering Codes	Weight (kg/lbs) ca. per 100	
	ØE	ØF	L1	L2	L4 min	L5	SW1	SW2					
Female Thread according to DIN 3852 - ISO 1179-1 - ANSI B 1.20.3													
	G 3/4"	51,8	31,45	91,5	57	16	34	34	34	QRC-IB-19-F-G12-VT-W5	56 123.46	QRC-IB-19-M-G12-V-W5	21 46.30
	NPTF 3/4" -14	51,8	31,45	91,5	57		34	34	34	QRC-IB-19-F-NF12-VT-W5	56,50 124.56	QRC-IB-19-M-NF12-V-W5	21,50 47.40

Note: The connection of the two halves of a coupling is achieved depending on the type. It is important to observe the positive engagement of plug-type couplings and the secure tightening of screw-type couplings to the limit stop of the thread. Forced or improper separation will result in malfunction of the coupling.



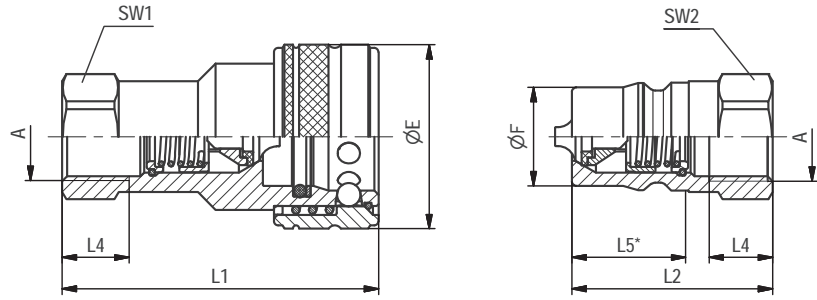

SW: Width across flats. All dimensions in mm (inch). Drawing similar Series IB-12.
* Insertion Male Tip.

Series IB-25 ▪ BG 6 ▪ Nominal Size 25

Port A	Dimensions (mm/in)								Female Body Ordering Codes	Weight (kg/lbs) ca. per 100	Male Tip Ordering Codes	Weight (kg/lbs) ca. per 100	
	ØE	ØF	L1	L2	L4 min	L5	SW1	SW2					
Female Thread according to DIN 3852 - ISO 1179-1 - ANSI B 1.20.3													
	G 1"	60	37,8	103,8	63,5	18	39,3	41	41	QRC-IB-25-F-G16-VT-W5	90,80	QRC-IB-25-M-G16-V-W5	34,20
		2.36	1.49	4.09	2.50	.71	1.55	1.61	1.61		200.18		75.40
	NPTF 1" -11 1/2	60	37,8	103,8	63,5		39,3	41	41	QRC-IB-25-F-NF16-VT-W5	91,80	QRC-IB-25-M-NF16-V-W5	35,20
		2.36	1.49	4.09	2.50		1.55	1.61	1.61		202.38		77.60

Series IB-38 ▪ BG 8 ▪ Nominal Size 38

Port A	Dimensions (mm/in)								Female Body Ordering Codes	Weight (kg/lbs) ca. per 100	Male Tip Ordering Codes	Weight (kg/lbs) ca. per 100	
	ØE	ØF	L1	L2	L4 min	L5	SW1	SW2					
Female Thread according to DIN 3852 - ISO 1179-1 - ANSI B 1.20.3													
	G 1 1/4"	78,5	44,45	126,5	127	20	52	65	65	QRC-IB-38-F-G20-VT-W5	216,60	QRC-IB-38-M-G20-V-W5	138,20
		3.09	1.75	4.98	5.00	.79	2.05	2.56	2.56		477.52		304.68
	NPTF 1 1/4" -11 1/2	78,5	44,45	126,5	127		52	65	65	QRC-IB-38-F-NF20-VT-W5	217,80	QRC-IB-38-M-NF20-V-W5	139,40
		3.09	1.75	4.98	5.00		2.05	2.56	2.56		480.17		307.32
	G 1 1/2"	78,5	44,45	126,5	127	22	52	65	65	QRC-IB-38-F-G24-VT-W5	208	QRC-IB-38-M-G24-V-W5	130,40
		3.09	1.75	4.98	5.00	.87	2.05	2.56	2.56		458.56		287.48
	NPTF 1 1/2" -11 1/2	78,5	44,45	126,5	127		52	65	65	QRC-IB-38-F-NF24-VT-W5	209,50	QRC-IB-38-M-NF24-V-W5	132
		3.09	1.75	4.98	5.00		2.05	2.56	2.56		461.87		291.01

Series IB-51 ▪ BG 9 ▪ Nominal Size 51

Port A	Dimensions (mm/in)								Female Body Ordering Codes	Weight (kg/lbs) ca. per 100	Male Tip Ordering Codes	Weight (kg/lbs) ca. per 100	
	ØE	ØF	L1	L2	L4 min	L5	SW1	SW2					
Female Thread according to DIN 3852 - ISO 1179-1 - ANSI B 1.20.3													
	G 2"	105	63,2	142	142,5	24	63,5	90	90	QRC-IB-51-F-G32-VT-W5	497	QRC-IB-51-M-G32-V-W5	329
		4.13	2.49	5.59	5.61	.94	2.50	3.54	3.54		1095.70		725.32
	NPTF 2" -11 1/2	105	63,2	142	142,5		63,5	90	90	QRC-IB-51-F-NF32-VT-W5	505	QRC-IB-51-M-NF32-V-W5	330
		4.13	2.49	5.59	5.61		2.50	3.54	3.54		1113.33		727.53

Note: The connection of the two halves of a coupling is achieved depending on the type. It is important to observe the positive engagement of plug-type couplings and the secure tightening of screw-type couplings to the limit stop of the thread. Forced or improper separation will result in malfunction of the coupling.

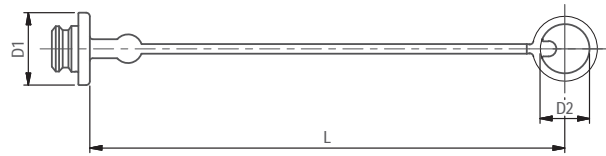
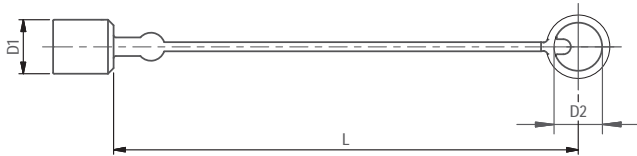

Series IB • Dust Protection

Dimensions (mm/in)			Material	Dust Cap for Male Tip
D1	D2	L		Ordering Codes
18	23	240	Plastic (Colour: Red)	QRC-IB-06-DM-23-KI-RD
.71	.91	9.45		
23	24	240	Plastic (Colour: Red)	QRC-IB-10-DM-24-KI-RD
.91	.94	9.45		
29	28	245	Plastic (Colour: Red)	QRC-IB-12-DM-28-KI-RD
1.14	1.10	9.65		
36,0	38	245	Plastic (Colour: Red)	QRC-IB-19-DM-38-KI-RD
1.42	1.50	9.65		
44	44	253	Plastic (Colour: Red)	QRC-IB-25-DM-44-KI-RD
1.73	1.73	9.96		

Dimensions (mm/in)			Material	Dust Plug for Female Body
D1	D2	L		Ordering Codes
26	23	240	Plastic (Colour: Red)	QRC-IB-06-DF-23-KI-RD
1.02	.91	9.45		
33	25	235	Plastic (Colour: Red)	QRC-IB-10-DF-25-KI-RD
1.30	.98	9.25		
38	29	240	Plastic (Colour: Red)	QRC-IB-12-DF-29-KI-RD
1.50	1.14	9.45		
49	38	240	Plastic (Colour: Red)	QRC-IB-19-DF-38-KI-RD
1.93	1.50	9.45		
60	46	245	Plastic (Colour: Red)	QRC-IB-25-DF-46-KI-RD
2.36	1.81	9.65		

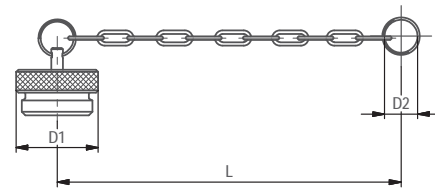
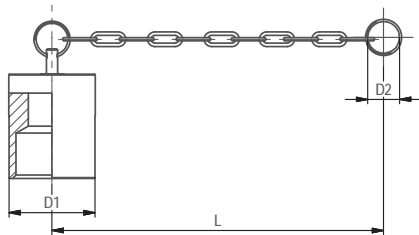

Dimensions (mm/in)			Material	Dust Cap for Male Tip
D1	D2	L		Ordering Codes
22	22	245	Aluminium with chain	QRC-IB-06-DM-28/CN-W89-SI
.87	.87	9.65		
27	30	155	Aluminium with chain	QRC-IB-10-DM-30/CN-W89-SI
1.06	1.18	6.10		
35	41	265	Aluminium with chain	QRC-IB-12-DM-41/CN-W89-SI
1.38	1.61	10.43		
42	30	250	Aluminium with chain	QRC-IB-19-DM-30/CN-W89-SI
1.65	1.18	9.84		
48	49	340	Aluminium with chain	QRC-IB-25-DM-49/CN-W89-SI
1.89	1.93	13.39		
55	46	225	Aluminium with chain	QRC-IB-38-DM-46/CN-W89-SI
2.17	1.81	8.86		
80	75	350	Aluminium with chain	QRC-IB-51-DM-75/CN-W89-SI
3.15	2.95	13.78		

Dimensions (mm/in)			Material	Dust Plug for Female Body
D1	D2	L		Ordering Codes
22	22	210	Aluminium with chain	QRC-IB-06-DF-30/CN-W89-SI
.87	.87	8.27		
22	30	155	Aluminium with chain	QRC-IB-10-DF-30/CN-W89-SI
.87	1.18	6.10		
28	41	305	Aluminium with chain	QRC-IB-12-DF-41/CN-W89-SI
1.10	1.61	12.01		
35	43	265	Aluminium with chain	QRC-IB-19-DF-43/CN-W89-SI
1.38	1.69	10.43		
44	41	240	Aluminium with chain	QRC-IB-25-DF-41/CN-W89-SI
1.73	1.61	9.45		
74	46	225	Aluminium with chain	QRC-IB-38-DF-46/CN-W89-SI
2.91	1.81	8.86		
105	75	350	Aluminium with chain	QRC-IB-51-DF-75/CN-W89-SI
4.13	2.95	13.78		

In addition to the standard colours as stated above, plastic dust caps are also available in blue, green, yellow and black. Please use the color codes BU, GN, YE and BK respectively instead of RD.



IB

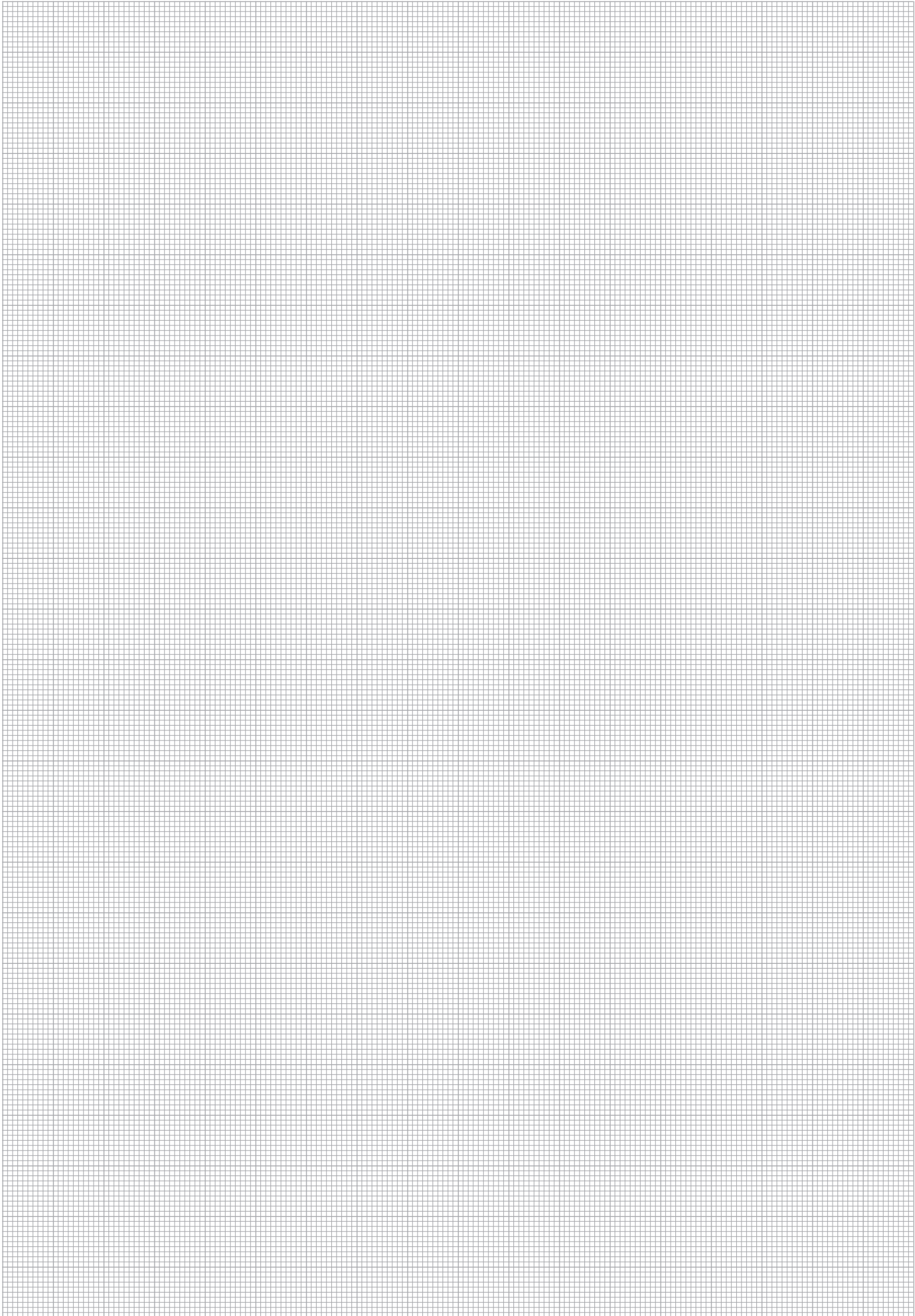

Series ID • Carbon Steel
Product Description

Push-to-Connect couplings of the ID Series from STAUFF consist of a male tip and a female body which are used for quick and easy connection (push) and disconnection of tubes, pipes and hoses by hand, i.e. without tools.

The Series was developed in the following nominal sizes 06, 10, 12, 19, 25 (1/4" - 1").

The proven design is suitable for use in agricultural and forestry machinery and hydraulic attachments. Other applications may, depending on the pressure and flow characteristics, include construction equipment, oil tools, oil equipment steel mill machinery, and other demanding industrial hydraulic applications.

Features

- poppet valve (open automatically when coupled, within rated working pressure, to keep the flow laminar)
- Coupling made from carbon steel with Zinc/Nickel surface coating
- Integrated locking system preventing unintentional release of the coupling

Applications

Agricultural and Forestry Machinery



Industrial Hydraulic

Top Features

Zinc/Nickel coating



Designed for secure connection

ID



Series ID • Carbon Steel

Material	Carbon Steel
Surface Finishing	Zinc-Nickel
Standard Seal Material(s)	NBR (Buna-N®) ²
Working Temperature	-25° C ... +100° C / -13° F ... +212° F
Valve Design	Poppet Valve
Connection	Push and actuate Push Sleeve
Disconnection	Actuate Push Sleeve
Connect Under Pressure	not allowed
Application	Industrial Hydraulic
ISO Interchange	-



² Alternative seal materials are available on request.

Technical Data

Series	BG	DN Zoll	DN metric ISO 4397	Q _{max}		Working Pressure		Bursting Pressure Connected		Female Body		Male Tip		Spillage	
				l/min	US GPM	bar	PSI	bar	PSI	bar	PSI	bar	PSI	ml	fl oz
ID-06	1	1/4"	6,3	18	4.76	400	5802	1700	24656	1400	20305	1600	23206	1	.0338
ID-10	2	3/8"	10	34,5	9.11	350	5076	1500	21756	1400	20305	1400	20305	2,4	.0812
ID-12	Technical data according to QRC-IA-12 Series, see page 58														
ID-19	4	3/4"	19 (20)	159	42.00	250	3626	1000	14504	1000	14504	750	10878	8,6	.2908
ID-25	6	1"	25	378	99.86	250	3626	1000	14504	1000	14504	750	10878	13	.4396

The indicated pressure ratings only apply to the coupling itself and depend on the connection type.

ID

Flow Characteristics

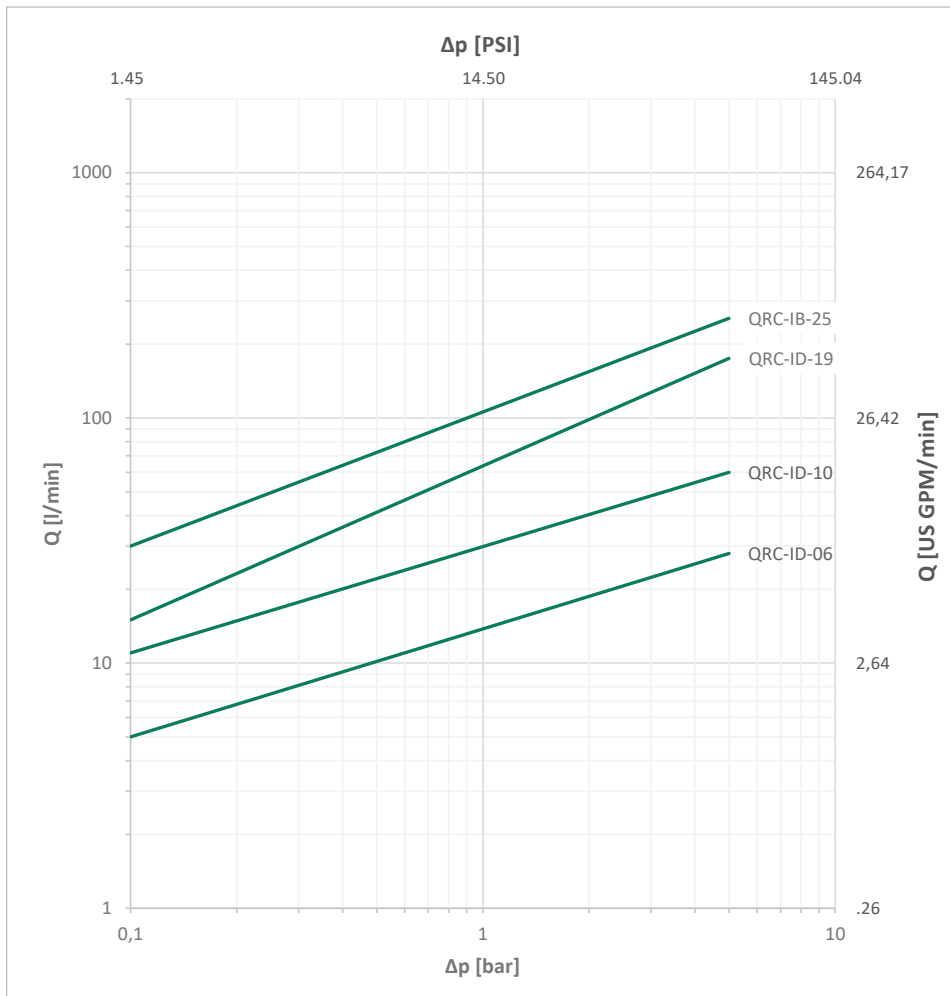

Please note: Unless otherwise stated, all flow characteristics have been determined with hydraulic oil with a kinematic viscosity of 28,8 - 35,2 mm²/s (28,8 - 35,2 cSt) and are only valid for components with non-reducing connections.



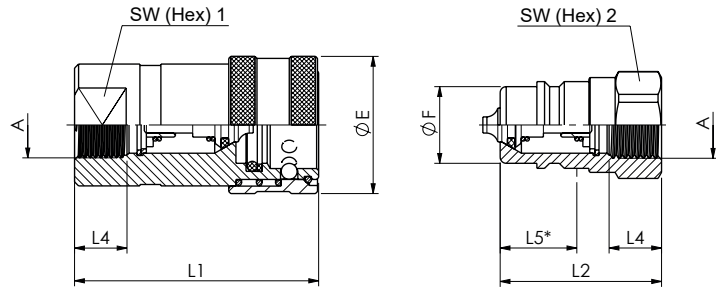

SW: Width across flats. All dimensions in mm (inch). Drawing similar Series ID-19.
* Insertion Male Tip.

Series ID-06 ▪ BG 1 ▪ Nominal Size 6,3

Port A	Dimensions (mm/in)								Female Body Ordering Codes	Weight (^{kg} /lbs) ca. per 100	Male Tip Ordering Codes	Weight (^{kg} /lbs) ca. per 100	
	ØE	ØF	L1	L2	L4 min	L5	SW1	SW2					
Female Thread according to DIN 3852 - ISO 1179-1 - ANSI B 1.20.3													
	G 1/4"	27,6	14,2	55,5	36	12	17,2	22	19	QRC-ID-06-F-G04-BT-W3	13,64	QRC-ID-06-M-G04-B-W3	4,71
		1,09	.56	2.19	1.42	.47	.68	.87	.75		30.07		10.38
	NPTF 1/4" -18	27,6	14,2	55,5	36		17,2	22	19	QRC-ID-06-F-NF04-BT-W3	13,64	QRC-ID-06-M-NF04-B-W3	4,71
		1,09	.56	2.19	1.42		.68	.87	.75		30.07		10.38

Series ID-10 ▪ BG 2 ▪ Nominal Size 10

Port A	Dimensions (mm/in)								Female Body Ordering Codes	Weight (^{kg} /lbs) ca. per 100	Male Tip Ordering Codes	Weight (^{kg} /lbs) ca. per 100	
	ØE	ØF	L1	L2	L4 min	L5	SW1	SW2					
Female Thread according to DIN 3852 - ISO 1179-1 - ANSI B 1.20.3													
	G 3/8"	34	19	60,5	40	13	20	24	24	QRC-ID-10-F-G06-BT-W3	25,14	QRC-ID-10-M-G06-B-W3	7,95
		1,34	.75	2.38	1.57	.51	.79	.94	.94		55.42		17.53
	NPTF 3/8" -18	34	19	60,5	40		20	24	24	QRC-ID-10-F-NF06-BT-W3	25,14	QRC-ID-10-M-NF06-B-W3	7,95
		1,34	.75	2.38	1.57		.79	.94	.94		55.42		17.53

Series ID-19 ▪ BG 4 ▪ Nominal Size 19

Port A	Dimensions (mm/in)								Female Body Ordering Codes	Weight (^{kg} /lbs) ca. per 100	Male Tip Ordering Codes	Weight (^{kg} /lbs) ca. per 100	
	ØE	ØF	L1	L2	L4 min	L5	SW1	SW2					
Female Thread according to DIN 3852 - ISO 1179-1 - ANSI B 1.20.3													
	G 3/4"	47,5	26,9	83	51	18	28,5	35	33	QRC-ID-19-F-G12-BT-W3	51,72	QRC-ID-19-M-G12-B-W3	15,44
		1,87	1,06	3,27	2,01	.71	1,12	1,38	1,30		114.02		34.04
	NPTF 3/4" -14	47,5	26,9	83	51		28,5	35	33	QRC-ID-19-F-NF12-BT-W3	51,72	QRC-ID-19-M-NF12-B-W3	15,44
		1,87	1,06	3,27	2,01		1,12	1,38	1,30		114.02		34.04

Series ID-25 ▪ BG 6 ▪ Nominal Size 25

Port A	Dimensions (mm/in)								Female Body Ordering Codes	Weight (^{kg} /lbs) ca. per 100	Male Tip Ordering Codes	Weight (^{kg} /lbs) ca. per 100	
	ØE	ØF	L1	L2	L4 min	L5	SW1	SW2					
Female Thread according to DIN 3852 - ISO 1179-1 - ANSI B 1.20.3													
	G 1"	56,2	31,3	97,5	64	21	33	41	41	QRC-ID-25-F-G16-BT-W3	95,77	QRC-ID-25-M-G16-B-W3	27,01
		2,21	1,23	3,84	2,52	.83	1,30	1,61	1,61		211.14		59.55
	NPTF 1" -11 1/2	56,2	31,3	97,5	64		33	41	41	QRC-ID-25-F-NF16-BT-W3	96,55	QRC-ID-25-M-NF16-B-W3	27,11
		2,21	1,23	3,84	2,52		1,30	1,61	1,61		212.86		59.77

Series ID-12: Technical data according to QRC-IA-12 Series, see page 60

Note: The connection of the two halves of a coupling is achieved depending on the type. It is important to observe the positive engagement of plug-type couplings and the secure tightening of screw-type couplings to the limit stop of the thread. Forced or improper separation will result in malfunction of the coupling.



Series ID ▪ Dust Protection

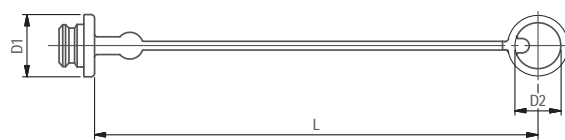
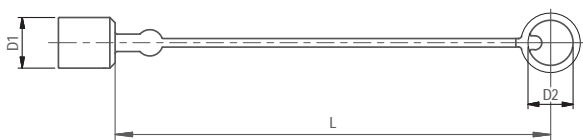

Dimensions (mm/in)			Material	Dust Cap for Male Tip
D1	D2	L		Ordering Codes
22	25	210	Plastic (Colour: Red)	QRC-ID-06-DM-25-KI-RD
.87	.98	8.27		
27	24	205	Plastic (Colour: Red)	QRC-ID-10-DM-24-KI-RD
1.06	.94	8.07		
37	33	270	Plastic (Colour: Red)	QRC-ID-19-DM-33-KI-RD
1.46	1.30	10.63		
41,0	39	290	Plastic (Colour: Red)	QRC-ID-25-DM-39-KI-RD
1.61	1.54	11.42		

Dimensions (mm/in)			Material	Dust Plug for Female Body
D1	D2	L		Ordering Codes
25	18	205	Plastic (Colour: Red)	QRC-ID-06-DF-18-KI-RD
.98	.71	8.07		
30	24	235	Plastic (Colour: Red)	QRC-ID-10-DF-24-KI-RD
1.18	.94	9.25		
44	33	270	Plastic (Colour: Red)	QRC-ID-19-DF-33-KI-RD
1.73	1.30	10.63		
50	39	290	Plastic (Colour: Red)	QRC-ID-25-DF-39-KI-RD
1.97	1.54	11.42		

In addition to the standard colours as stated above, plastic dust caps are also available in blue, green, yellow and black. Please use the color codes BU, GN, YE and BK respectively instead of RD.

ID



Series BP • Carbon Steel
Product Description

Push-to-Connect couplings of the BP Series from STAUFF consist of a male tip and a female body which are used for quick and easy connection (push) and disconnection of tubes, pipes and hoses by hand, i.e. without tools.

The Series was developed according to ISO 5676 in the nominal size 12,5 (1/2").

The proven design is suitable for use in hydraulic braking systems of tractors and trailers.

Features

- Flat Face
- Coupling made from carbon steel with Zinc/Nickel surface coating
- Integrated locking system preventing unintentional release of the coupling
- ISO Interchange acc. to ISO 5676
- Female body is supplied with a parking station
- Male tip can be panel mounted

Applications

Agricultural and Forestry Machinery



Hydraulic trailers

Top Features

Zinc/Nickel coating



Suitable for panel mounting



Designed for secure connection

BP



Series BP ▪ Carbon Steel

Material	Carbon Steel
Surface Finishing	Zinc-Nickel
Standard Seal Material(s)	NBR (Buna-N®), PTFE ²
Working Temperature	-25° C ... +100° C / -13° F ... +212° F
Valve Design	Flat Face
Connection	Push and actuate Push Sleeve
Disconnection	Actuate Push Sleeve
Connect Under Pressure	not allowed
Application	Agricultural and Forestry Machinery
ISO Interchange	ISO 5676



²Alternative seal materials are available on request.

Technical Data

Series	BG	DN Zoll	DN metric ISO 4397	Q _{max}		Working Pressure		Bursting Pressure Connected		Female Body		Male Tip		Spillage	
				l/min	US GPM	bar	PSI	bar	PSI	bar	PSI	bar	PSI	ml	fl oz
BP-12	3	1/2"	12,5	34,5	9.11	150	2175	1000	14504	620	8992	900	13053	0,05	.0017

The indicated pressure ratings only apply to the coupling itself and depend on the connection type.

BP

Flow Characteristics

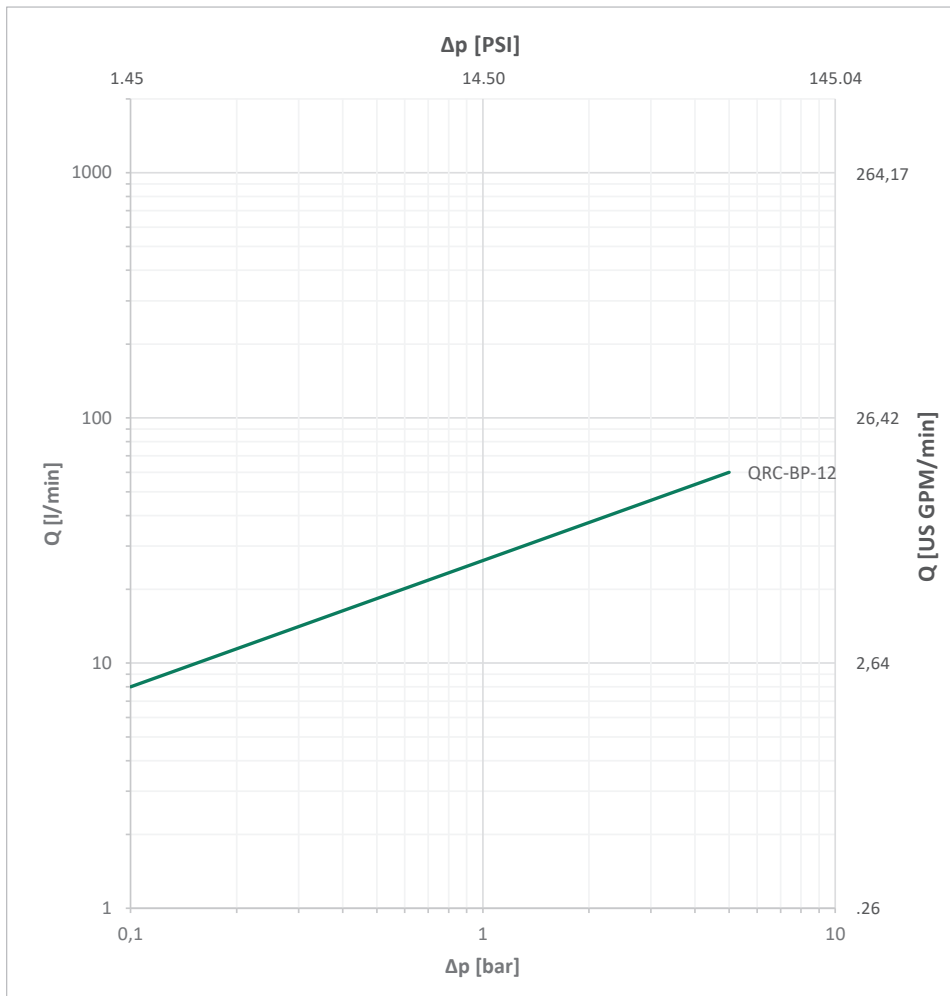

Please note: Unless otherwise stated, all flow characteristics have been determined with hydraulic oil with a kinematic viscosity of 28,8 - 35,2 mm²/s (28,8 - 35,2 cSt) and are only valid for components with non-reducing connections.



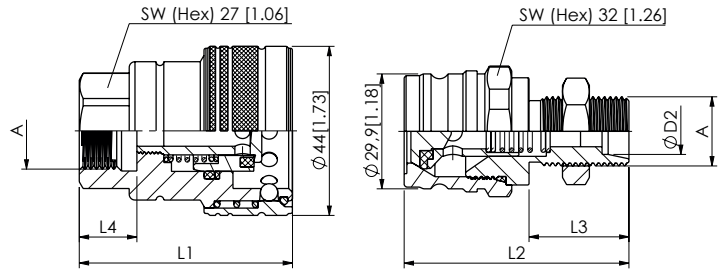

SW: Width across flats. All dimensions in mm (inch).

Series BP-12 ▪ BG 3 ▪ Nominal Size 12,5

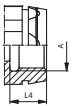
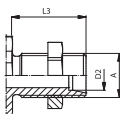
Port A	Dimensions (mm/in)				Female Body* Ordering Codes	Weight (^{kg} /lbs) ca. per 100	Male Tip Ordering Codes	Weight (^{kg} /lbs) ca. per 100
	ØD2	L1	L2	L3 L4				
Female Thread according to DIN 3852 - ISO 1179-1								
	G 1/2"		55,5 2.19		15 .59	QRC-BP-12-FDS-G08-BT-W3	33,65 74.19	
	M18x1,5		55,5 2.19		15 .59	QRC-BP-12-FDS-M180R-BT-W3	34,34 75.71	
Male Thread with 24° Conical Bore - Bulkhead - Shape W according to DIN 3861								
	M18x1,5	12L	55,8 2.20	26 1.02		QRC-BP-12-M-12LB-B-W3	17,76 39.15	
	M22x1,5	15LB	60,5 2.38	28 1.10		QRC-BP-12-M-15LB-B-W3	20,31 44.78	

* Delivery standard of the female body includes a parking station.

Series BP ▪ Dust Protection



Dimensions (mm/in)			Material	Dust Cap for Male Tip
D1	D2	L		Ordering Codes
30 1.18	29,5 1.16	185 7.28	Plastic (Colour: Red)	QRC-BP-10-DM-30-K-RD

Dimensions (mm/in)			Material	Dust Plug for Female Body
D1	D2	L		Ordering Codes
29 1.14	29,5 1.16	185 7.28	Plastic (Colour: Red)	QRC-BP-10-DF-30-K-RD

Note: The connection of the two halves of a coupling is achieved depending on the type. It is important to observe the positive engagement of plug-type couplings and the secure tightening of screw-type couplings to the limit stop of the thread. Forced or improper separation will result in malfunction of the coupling.

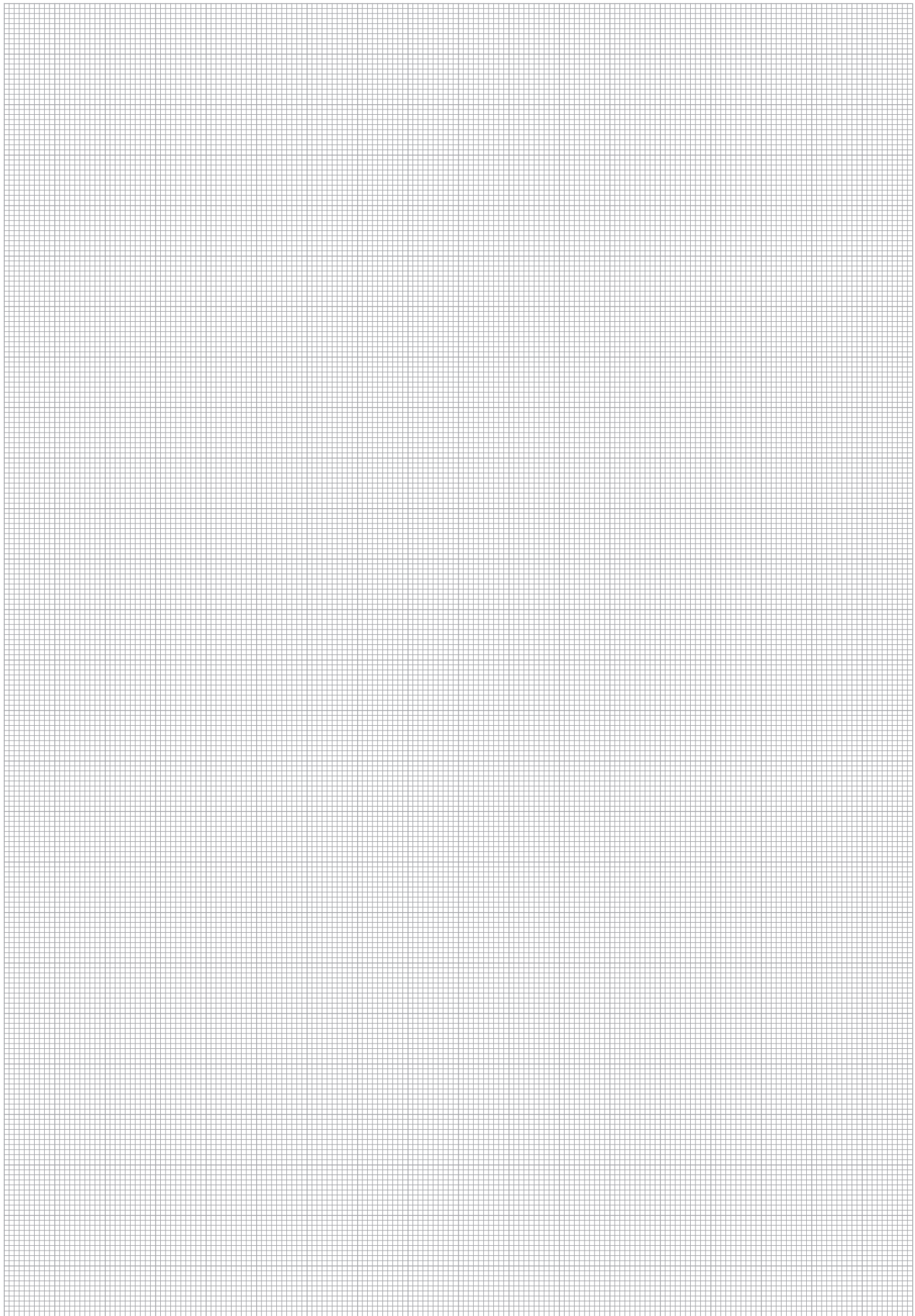

BP





Series HC ▪ Carbon Steel

Material	Carbon Steel
Surface Finishing	Zinc-Plating and Thick-Film-Passivation (Chrome III)
Standard Seal Material(s)	Special compound ²
Working Temperature	-35° C ... +130° C / -31° F ... +266° F
Valve Design	Flat Face
Connection	Push and actuate Push Sleeve
Disconnection	Actuate Push Sleeve
Connect Under Pressure	not allowed
Application	Rescue and Tensioning Hydraulics
ISO Interchange	-



² Alternative seal materials are available on request.

Technical Data

Series	BG	DN Zoll Inch	DN metric ISO 4397	Q _{max}		Working Pressure		Bursting Pressure Connected		Female Body		Male Tip		Spillage	
				l/min	US GPM	bar	PSI	bar	PSI	bar	PSI	bar	PSI	ml	fl oz
HC-06	1	1/4"	6,3	6	1.59	1000	14504	2500	36260	2500	36260	2500	36260	0,008	.0003

The indicated pressure ratings only apply to the coupling itself and depend on the connection type.

HC

Flow Characteristics

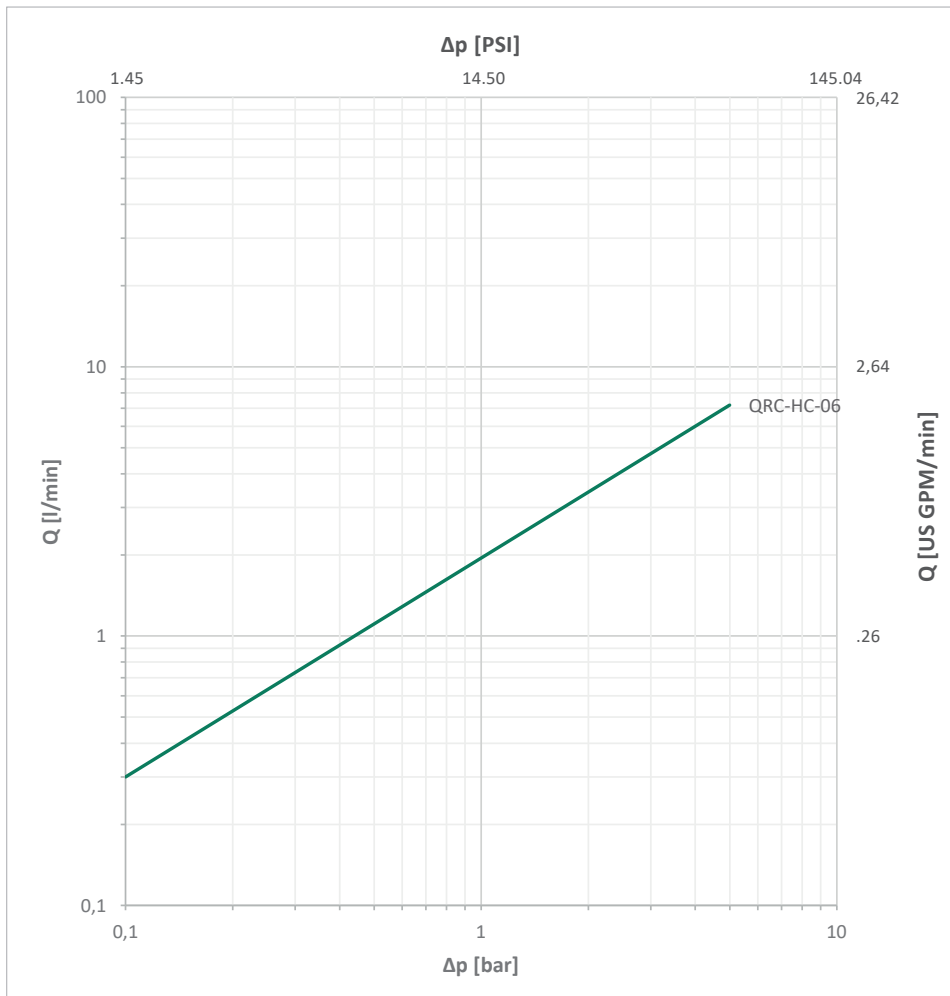

Please note: Unless otherwise stated, all flow characteristics have been determined with hydraulic oil with a kinematic viscosity of 28,8 - 35,2 mm²/s (28,8 - 35,2 cSt) and are only valid for components with non-reducing connections.



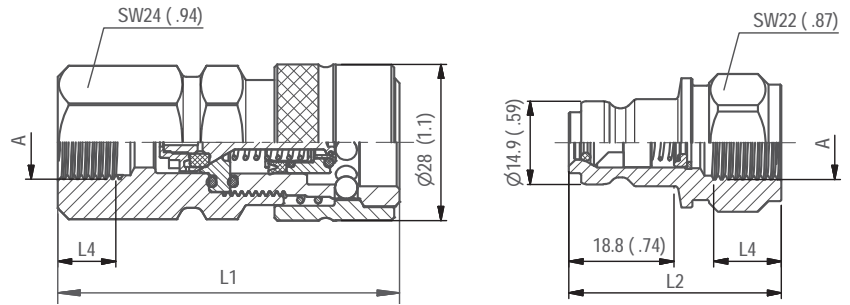

SW: Width across flats. All dimensions in mm (inch).

Series HC-06 ▪ BG 1 ▪ Nominal Size 6,3

Port A	Dimensions (mm/in)				Female Body Ordering Codes	Weight (^{kg} /lbs) ca. per 100	Male Tip Ordering Codes	Weight (^{kg} /lbs) ca. per 100
	ØD2	L1	L2	L3				
Female Thread according to DIN 3852 - ISO 1179-1 - ANSI B 1.20.3								
	G 1/8"	54,3 2.14	38,1 1.50		8 0.31	QRC-HC-06-F-G02-Y-W66 17,60 38.80	QRC-HC-06-M-G02-Y-W66 7,80 17.20	
	G 1/4"	61,3 2.41	38,1 1.50		12 0.47	QRC-HC-06-F-G04-Y-W66 19,50 42.99	QRC-HC-06-M-G04-Y-W66 7,10 15.65	
	NPTF 1/4" -18	58,3 2.30	35,7 1.41			QRC-HC-06-F-NF04-Y-W66 18,60 41.01	QRC-HC-06-M-NF04-Y-W66 6,70 14.77	
	G 3/8"	63,3 2.49	39,6 1.56		12 0.47	QRC-HC-06-F-G06-Y-W66 19,30 42.55	QRC-HC-06-M-G06-Y-W66 8,40 18.52	
	NPTF 3/8" -18	60,3 2.37	39,6 1.56			QRC-HC-06-F-NF06-Y-W66 18,50 40.79	QRC-HC-06-M-NF06-Y-W66 7,80 17.20	

Series HC ▪ Dust Protection

Dimensions (mm/in)			Material	Dust Cap for Male Tip
D1	D2	L		Ordering Codes
29 1.14	22,5 .89	110 4.33	Plastic (Colour: Red)	QRC-HC-06-DM-23-KI-RD

Dimensions (mm/in)			Material	Dust Plug for Female Body
D1	D2	L		Ordering Codes
29 1.14	20,5 .81	110 4.33	Plastic (Colour: Red)	QRC-HC-06-DF-21-KI-RD

In addition to the standard colours as stated above, plastic dust caps are also available in blue, green, yellow and black. Please use the color codes BU, GN, YE and BK respectively instead of RD.

HC

Note: The connection of the two halves of a coupling is achieved depending on the type. It is important to observe the positive engagement of plug-type couplings and the secure tightening of screw-type couplings to the limit stop of the thread. Forced or improper separation will result in malfunction of the coupling.



HC

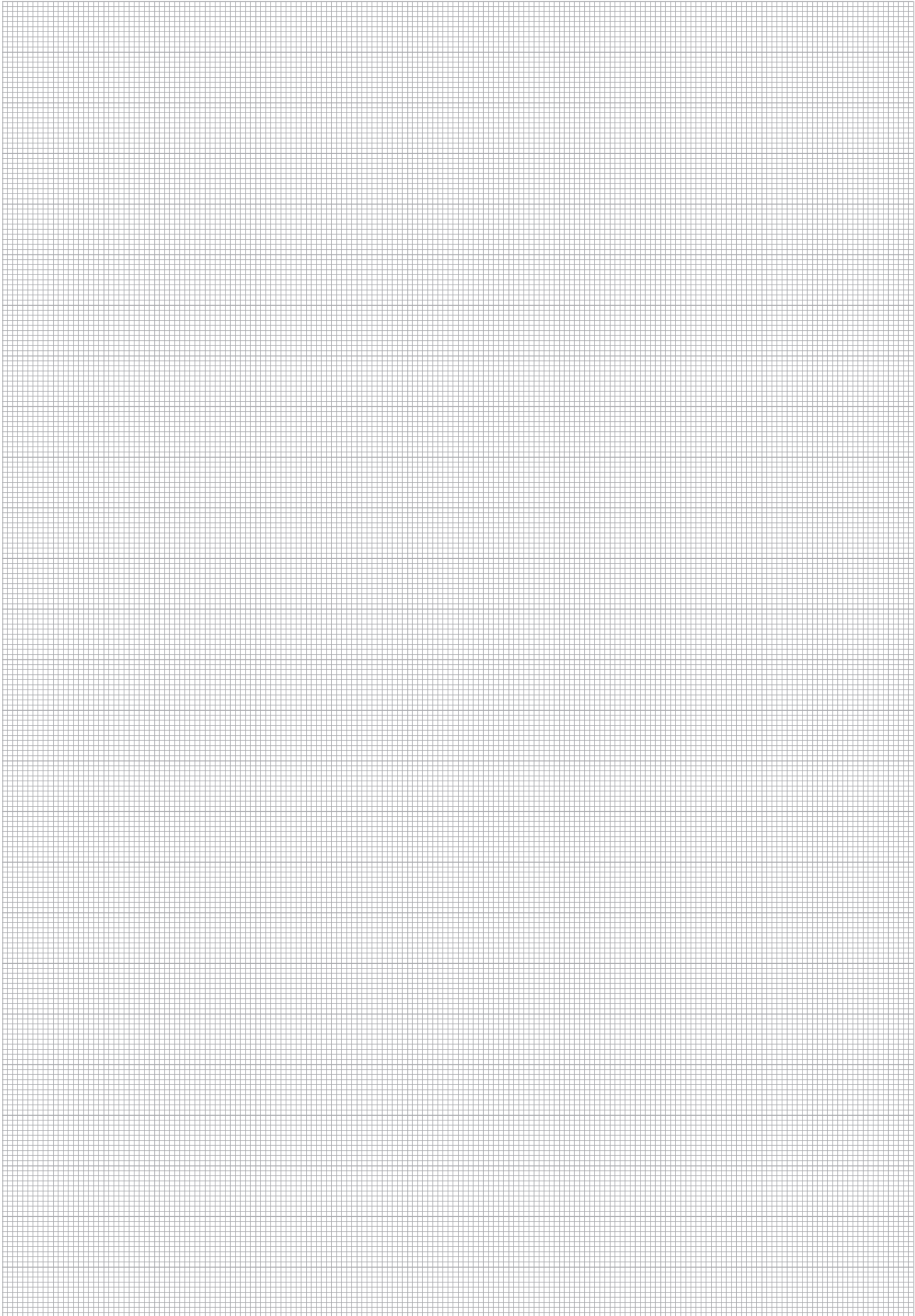



Series HD ▪ Carbon Steel

Material	Carbon Steel
Surface Finishing	Zinc-Plating and Thick-Film-Passivation (Chrome III)
Standard Seal Material(s)	Special compound ²
Working Temperature	-35° C ... +130° C / -31° F ... +266° F
Valve Design	Flat Face
Connection	Push and actuate Push Sleeve
Disconnection	Actuate Push Sleeve
Connect Under Pressure	not allowed
Application	Rescue and Tensioning Hydraulics
ISO Interchange	-



² Alternative seal materials are available on request.

Technical Data

Series	BG	DN Zoll Inch	DN metric ISO 4397	Q _{max}		Working Pressure		Bursting Pressure Connected		Female Body		Male Tip		Spillage	
				l/min	US GPM	bar	PSI	bar	PSI	bar	PSI	bar	PSI	ml	fl oz
HD-06	1	1/4"	6,3	6	1.59	1500	21756	3500	50763	3500	50763	3500	50763	0,008	.0003

The indicated pressure ratings only apply to the coupling itself and depend on the connection type.

HD

Flow Characteristics

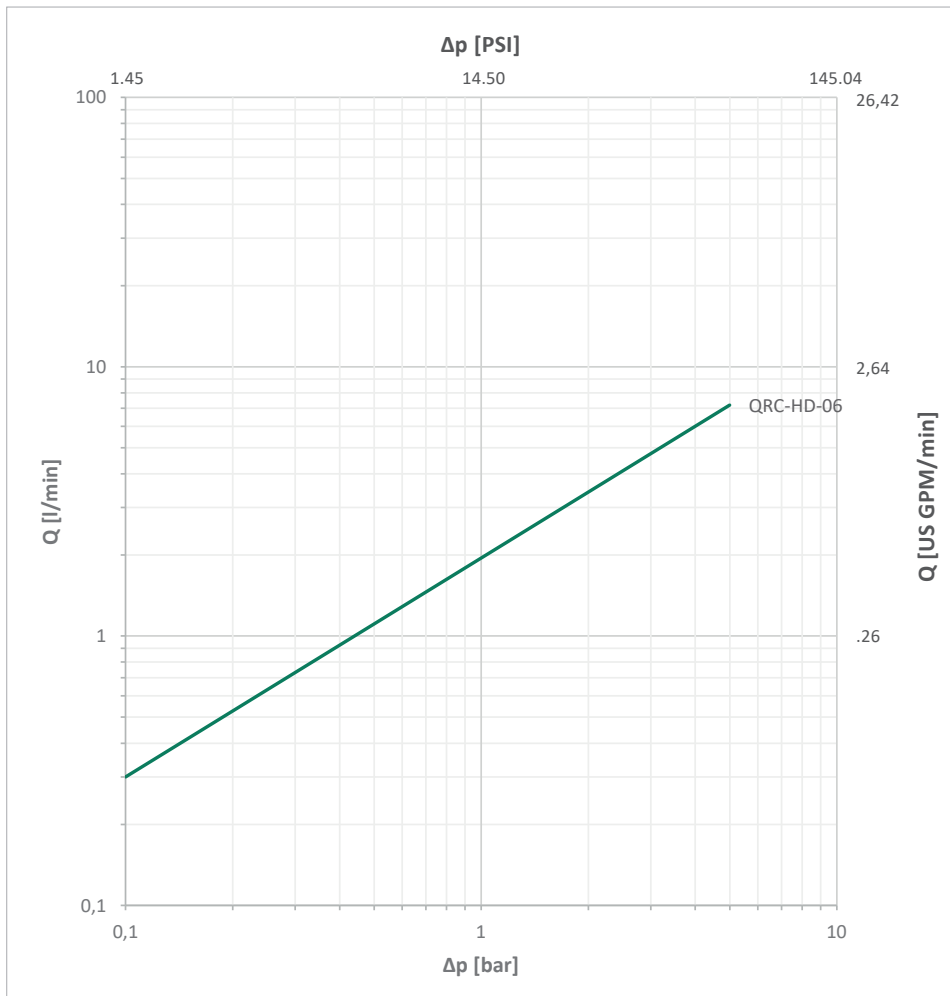

Please note: Unless otherwise stated, all flow characteristics have been determined with hydraulic oil with a kinematic viscosity of 28,8 - 35,2 mm²/s (28,8 - 35,2 cSt) and are only valid for components with non-reducing connections.



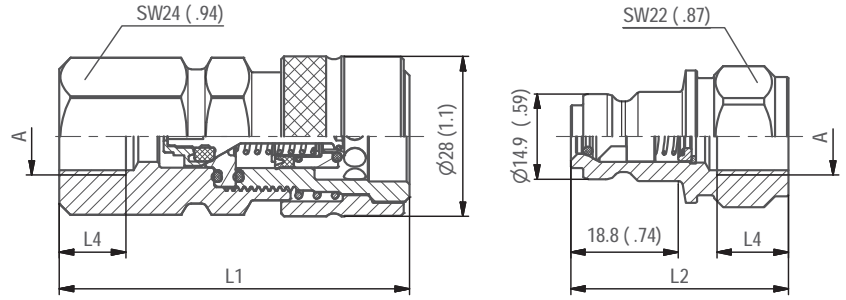

SW: Width across flats. All dimensions in mm (inch).

Series HD-06 ▪ BG 1 ▪ Nominal Size 6,3

Port A	Dimensions (mm/in)					Female Body Ordering Codes	Weight (^{kg} /lbs) ca. per 100	Male Tip Ordering Codes	Weight (^{kg} /lbs) ca. per 100
	$\varnothing D2$	L1	L2	L3	L4 min				
Female Thread according to DIN 3852 - ISO 1179-1 - ANSI B 1.20.3									
	G 1/4"	61,3 2.41	38,1 1.50		12 0.47	QRC-HD-06-F-G04-Y-W66	19,60 43.21	QRC-HD-06-M-G04-Y-W66	7,10 15.65
	NPTF 1/4" -18	58,3 2.30	35,7 1.41				QRC-HD-06-F-NF04-Y-W66	18,60 41.01	QRC-HD-06-M-NF04-Y-W66

Series HD ▪ Dust Protection

HD

Dimensions (mm/in)			Material	Dust Cap for Male Tip
D1	D2	L		Ordering Codes
29	22,5	110	Plastic (Colour: Black)	QRC-HD-06-DM-23-KI-BK
1.14	.89	4.33		

Dimensions (mm/in)			Material	Dust Plug for Female Body
D1	D2	L		Ordering Codes
29	20,5	110	Plastic (Colour: Black)	QRC-HD-06-DF-21-KI-BK
1.14	.81	4.33		

Note: The connection of the two halves of a coupling is achieved depending on the type. It is important to observe the positive engagement of plug-type couplings and the secure tightening of screw-type couplings to the limit stop of the thread. Forced or improper separation will result in malfunction of the coupling.



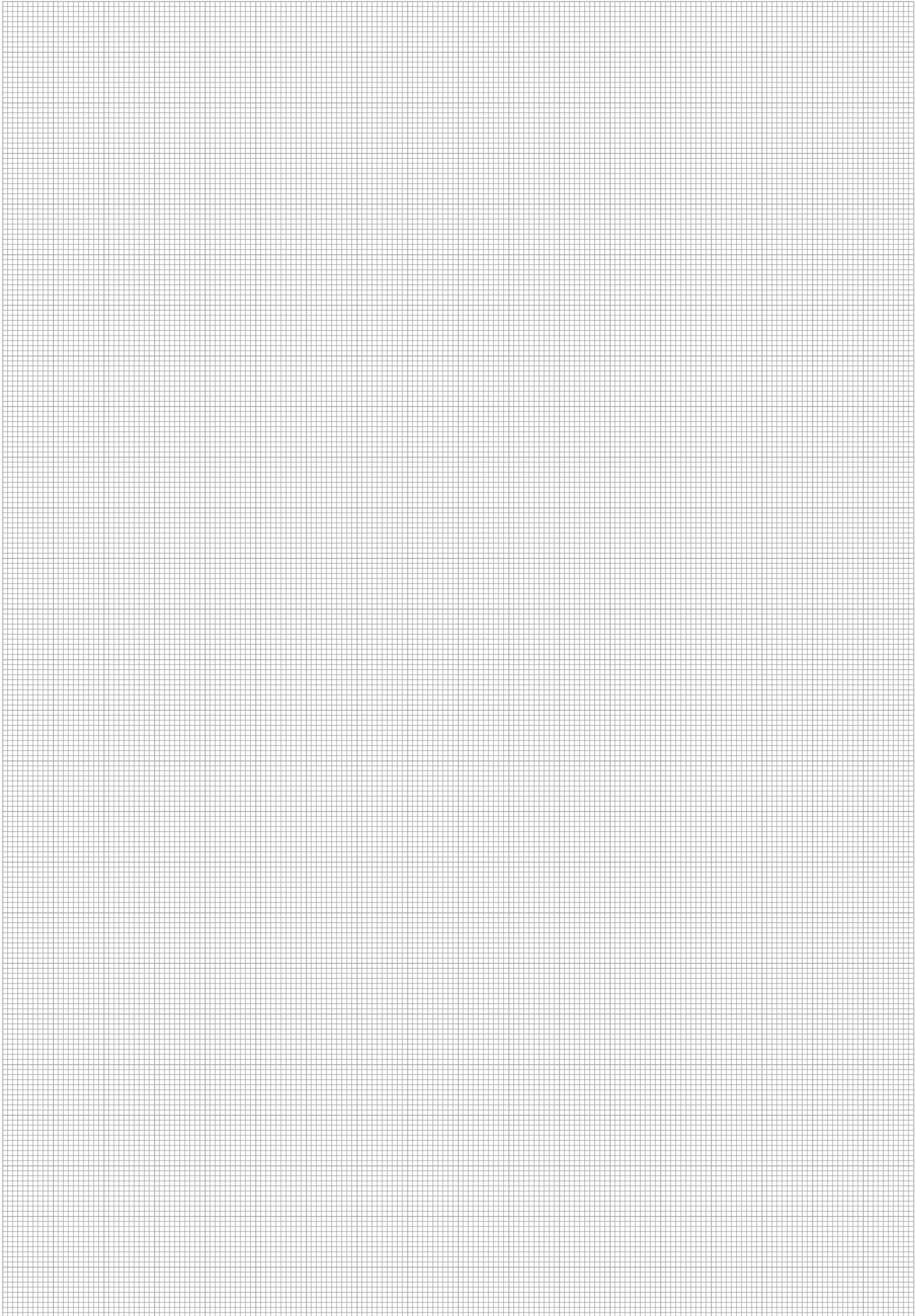

HD



Series HUS • Carbon Steel
Product Description

Push-to-Connect couplings of the HUS Series from STAUFF consist of a male tip and a female body which are used for quick and easy connection (push) and disconnection of tubes, pipes and hoses by hand, i.e. without tools.

The proven design is suitable for use in agricultural and forestry machinery, construction machinery and hydraulic attachments.

The Series was developed for coupling Under pressure according to the Nordic interchange in the following nominal sizes 10, 12, 19, 25 (3/8" - 1").

Features

- poppet valve
- Coupling made from carbon steel with Zinc/Nickel surface coating
- Integrated locking system preventing unintentional release of the coupling
- Nordic interchange
- Female body is supplied with safety locking ring
- Male and Female poppet valves fitted with decompression valve (pressure eliminator)

Applications

Agricultural and Forestry Machinery



Construction Machinery



Industrial Hydraulic

Top Features

Zinc/Nickel coating



Connect Under pressure



Designed for secure connection

HUS



Series HUS - Carbon Steel

Material	Carbon Steel
Surface Finishing	Zinc-Nickel
Standard Seal Material(s)	NBR (Buna-N®) ²
Working Temperature	-30° C ... +106° C / -22° F ... +223° F
Valve Design	Poppet Valve
Connection	Push
Disconnection	Actuate Push Sleeve
Connect Under Pressure	Male Tip/Female Body
Application	Construction Machinery, Industrial Hydraulic
ISO Interchange	-



²Alternative seal materials are available on request.

Technical Data

Series	BG	DN Zoll Inch	DN metric ISO 4397	Q _{max}		Working Pressure		Bursting Pressure Connected		Female Body		Male Tip		Spillage	
				l/min	US GPM	bar	PSI	bar	PSI	bar	PSI	bar	PSI	ml	fl oz
HUS-10	2	3/8"	10	30	7.93	350	5076	1050	15229	1450	21031	1500	21756		
HUS-12	3	1/2"	12,5	67,5	17.83	315	4569	1000	14504	1200	17405	1000	14504		
HUS-19	4	3/4"	19 (20)	159	42.00	270	3916	1080	15664	1000	14504	900	13053		
HUS-25	6	1"	25	378	99.86	270	3916	900	13053	900	13053	900	13053		

The indicated pressure ratings only apply to the coupling itself and depend on the connection type.

Flow Characteristics

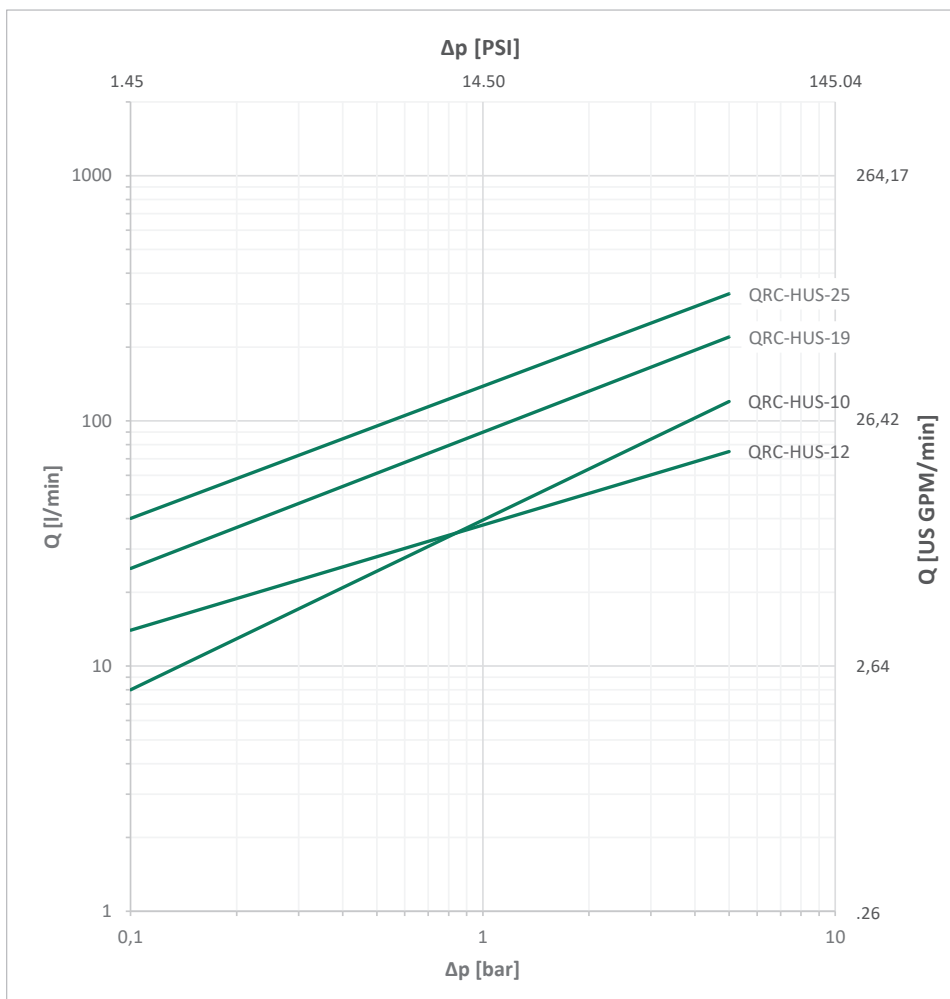

Please note: Unless otherwise stated, all flow characteristics have been determined with hydraulic oil with a kinematic viscosity of 28,8 - 35,2 mm²/s (28,8 - 35,2 cSt) and are only valid for components with non-reducing connections.



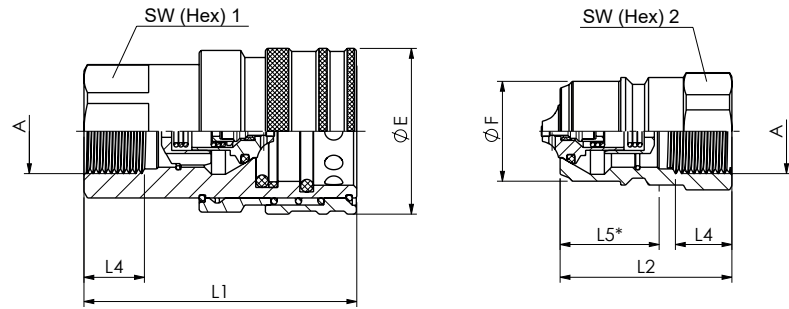

SW: Width across flats. All dimensions in mm (inch).

Series HUS-10 ▪ BG 2 ▪ Nominal Size 10

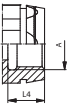
Port A	Dimensions (^{mm} / _{in})									Female Body Ordering Codes	Weight (*9/10) ca. per 100	Male Tip Ordering Codes	Weight (*9/10) ca. per 100
	ØE	ØF	L1	L2	L4 min	L5	SW1	SW2					
Female Thread according to DIN 3852 - ISO 1179-1 - ANSI B 1.20.3													
	G 3/8"	35	19,9	61,6	38	12	23	24	22	QRC-HUS-10-F-G06-BT-W3	23,71	QRC-HUS-10-M-G06-B-W3	5,89
		1,38	.78	2,43	1,50	.47	.91	.94	.87		52,27		12,99

Series HUS-12 ▪ BG 3 ▪ Nominal Size 12,5

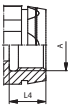
Port A	Dimensions (^{mm} / _{in})									Female Body Ordering Codes	Weight (*9/10) ca. per 100	Male Tip Ordering Codes	Weight (*9/10) ca. per 100
	ØE	ØF	L1	L2	L4 min	L5	SW1	SW2					
Female Thread according to DIN 3852 - ISO 1179-1 - ANSI B 1.20.3													
	G 1/2"	41	24,7	67,5	42,5	14	24,5	30	27	QRC-HUS-12-F-G08-BT-W3	35,83	QRC-HUS-12-M-G08-B-W3	9,56
		1,61	.97	2,66	1,67	.55	.96	1,18	1,06		78,99		21,08

HUS
Series HUS-19 ▪ BG 4 ▪ Nominal Size 19

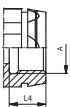
Port A	Dimensions (^{mm} / _{in})									Female Body Ordering Codes	Weight (*9/10) ca. per 100	Male Tip Ordering Codes	Weight (*9/10) ca. per 100
	ØE	ØF	L1	L2	L4 min	L5	SW1	SW2					
Female Thread according to DIN 3852 - ISO 1179-1 - ANSI B 1.20.3													
	G 3/4"	52	32,7	76,4	47	18	28,5	38	36	QRC-HUS-19-F-G12-BT-W3	62,09	QRC-HUS-19-M-G12-B-W3	19,34
		2,05	1,29	3,01	1,85	.71	1,12	1,50	1,42		136,89		42,64

Series HUS-25 ▪ BG 6 ▪ Nominal Size 25

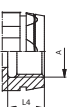
Port A	Dimensions (^{mm} / _{in})									Female Body Ordering Codes	Weight (*9/10) ca. per 100	Male Tip Ordering Codes	Weight (*9/10) ca. per 100
	ØE	ØF	L1	L2	L4 min	L5	SW1	SW2					
Female Thread according to DIN 3852 - ISO 1179-1 - ANSI B 1.20.3													
	G 1"	62	40,9	92,4	56,5	20	35	45	45	QRC-HUS-25-F-G16-BT-W3	102,41	QRC-HUS-25-M-G16-B-W3	35,97
		2,44	1,61	3,64	2,22	.79	1,38	1,77	1,77		225,78		79,30

Note: The connection of the two halves of a coupling is achieved depending on the type. It is important to observe the positive engagement of plug-type couplings and the secure tightening of screw-type couplings to the limit stop of the thread. Forced or improper separation will result in malfunction of the coupling.





Series MK

Series MK - Overview	112
Series MK-Q-10/4 - BG 2 - Nominal Size 10	113
Series MK-R-10/4 - BG 2 - Nominal Size 10	114

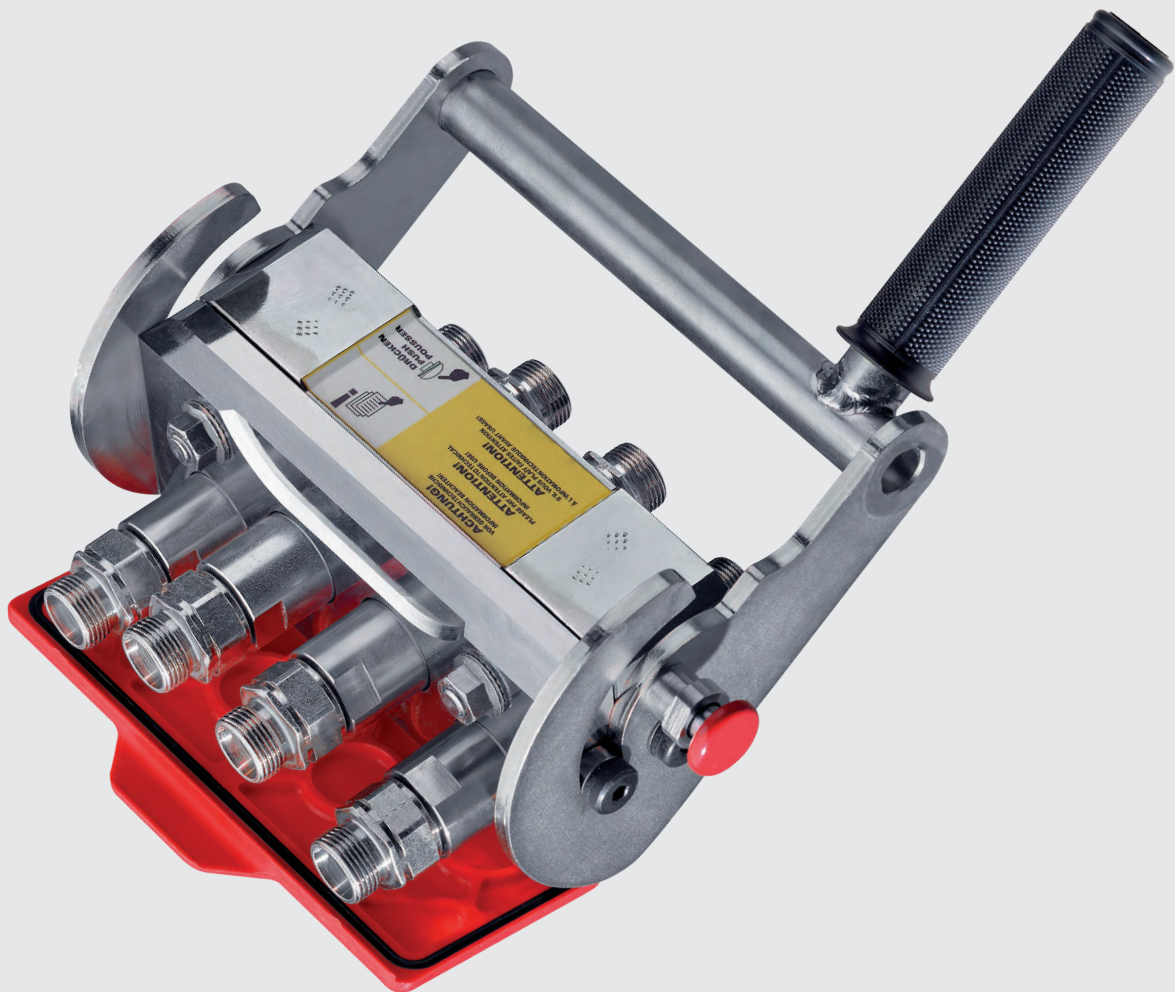

MK



Series MK

Description

The multi-coupling has been created for connecting and disconnecting several hydraulic lines at the same time. This is done by an operating lever the guide crank of which is designed for a minimum of operating force.

The connection of the hydraulic lines is done with flat face couplings. Due to the special sealing it is possible to couple against trapped pressure on the male halves (max. 4x100 bar / 4x1450 PSI)

The main features of the multi coupling are:

- Safety against commutability of hydraulic lines
- Quick connecting
- Coupling against trapped pressure
- Optimally minimized spillage during coupling process

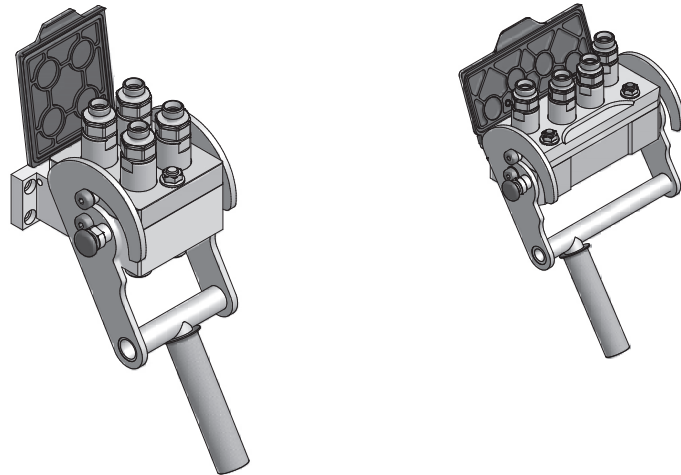

Spare Parts

The following list shows the spare parts available for the line of the multi-coupling products. They are supplied in form of kits, including detailed removal and installation instructions:

Description	MK 24	MK 74
	Ordering Codes	Ordering Codes
Operating lever kit	QRC-MK-Q-10/4-SP-OL-W3	QRC-MK-R-10/4-SP-OL-W3
Safety lock kit	QRC-MK-Q-10/4-SP-SL-W3	QRC-MK-Q-10/4-SP-SL-W3
Dust protection kit	QRC-MK-Q-10/4-SP-DP-K	QRC-MK-R-10/4-SP-DP-K
Female coupling	QRC-EK-10-F-XXX-BT-W3	QRC-EK-10-F-XXX-BT-W3
Centering bolt kit	QRC-MK-Q-10/4-SP-CB-W3	QRC-MK-Q-10/4-SP-CB-W3
Guide screw kit	QRC-MK-Q-10/4-SP-GS-W4	QRC-MK-Q-10/4-SP-GS-W4
Male coupling	QRC-EK-10-M-XXX-BP-W3	QRC-EK-10-M-XXX-BP-W3
Seal kit (20 pcs.)	QRC-EK-10-MSK-PU	QRC-EK-10-MSK-PU

MK

Note: The connection of the two halves of a coupling is achieved depending on the type. It is important to observe the positive engagement of plug-type couplings and the secure tightening of screw-type couplings to the limit stop of the thread. Forced or improper separation will result in malfunction of the coupling.



Working Pressure

250 bar / 25 MPa / 3626 PSI (2 x 250 bar, 2 x 40 bar)

Material

Steel

Surface Finishing

Zinc-Nickel

Standard Seal Material(s)

NBR (Buna-N®), PTFE, PU

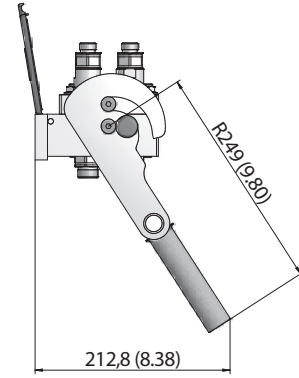
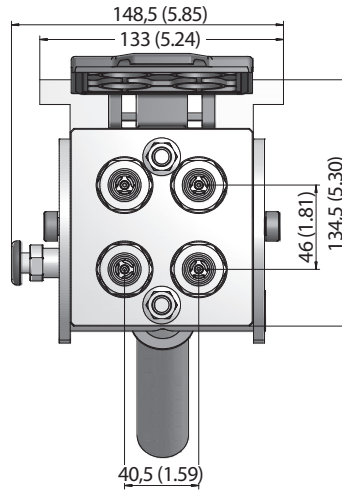

SW: Width across flats. All dimensions in mm (inch).

Series MK-Q-10/4 24 · BG 2 · Nominal Size 10

	Port A	Dimensions (mm/in)	Fixed half Ordering Codes	Weight (kg/lbs) ca. per 100	Mobile half Ordering Codes	Weight (kg/lbs) ca. per 100	Multicoupling System Ordering Codes	Weight (kg/lbs) ca. per 100
Female Thread according to DIN 3852-2-A - ANSI B 1.20.3								
	G 3/8"		QRC-MK-Q-10/4-FP-G06-BT-W3	581 1280.89	QRC-MK-Q-10/4-MP-G06-BP-W3	283 623.91	QRC-MK-Q-10/4-CC-G06-S1-W3	864 1904.79
	G 1/2"		QRC-MK-Q-10/4-FP-G08-BT-W3	581 1280.89	QRC-MK-Q-10/4-MP-G08-BP-W3	283 623.91	QRC-MK-Q-10/4-CC-G08-S1-W3	864 1904.79
	NPTF 1/2" - 14		QRC-MK-Q-10/4-FP-NF08-BT-W3	581 1280.89	QRC-MK-Q-10/4-MP-NF08-BP-W3	283 623.91	QRC-MK-Q-10/4-CC-NF08-S1-W3	864 1904.79
Male Thread with 24° Conical Bore - Shape W according to DIN 3861								
	M16x1,5	10L	QRC-MK-Q-10/4-FP-10L-BT-W3	557 1227.98	QRC-MK-Q-10/4-MP-10L-BP-W3	259 571.00	QRC-MK-Q-10/4-CC-10L-S1-W3	816 1798.97
	M18x1,5	12L	QRC-MK-Q-10/4-FP-12L-BT-W3	565 1245.61	QRC-MK-Q-10/4-MP-12L-BP-W3	259 571.00	QRC-MK-Q-10/4-CC-12L-S1-W3	824 1816.61
	M22x1,5	15L	QRC-MK-Q-10/4-FP-15L-BT-W3	565 1245.61	QRC-MK-Q-10/4-MP-15L-BP-W3	267 588.63	QRC-MK-Q-10/4-CC-15L-S1-W3	832 1834.25
	M26x1,5	18L	QRC-MK-Q-10/4-FP-18L-BT-W3	581 1280.89	QRC-MK-Q-10/4-MP-18L-BP-W3	267 588.63	QRC-MK-Q-10/4-CC-18L-S1-W3	848 1869.25

MK

Note: The connection of the two halves of a coupling is achieved depending on the type. It is important to observe the positive engagement of plug-type couplings and the secure tightening of screw-type couplings to the limit stop of the thread. Forced or improper separation will result in malfunction of the coupling.



Working Pressure

250 bar / 25 MPa / 3626 PSI (2 x 250 bar, 2 x 40 bar)

Material

Steel

Surface Finishing

Zinc-Nickel

Standard Seal Material(s)

NBR (Buna-N®), PTFE, PU

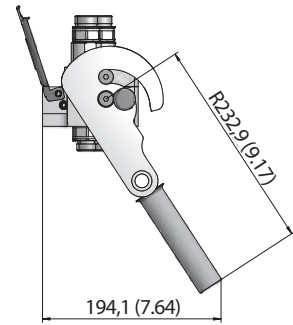
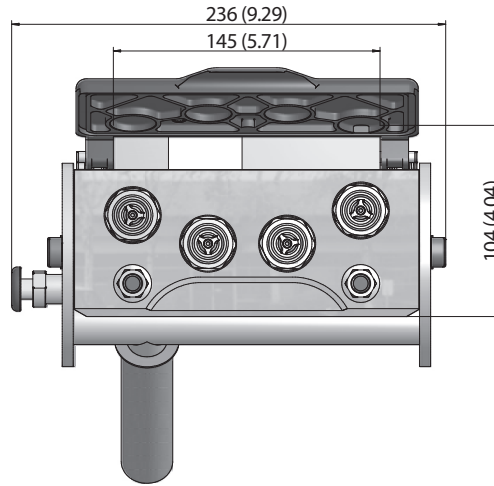

SW: Width across flats. All dimensions in mm (inch).

Series MK-R-10/4 • BG 2 • Nominal Size 10

Port A	Abmessung (mm/in)	Fixed half Ordering Codes	Weight (^{kg} /lbs) ca. per 100	Mobile half Ordering Codes	Weight (^{kg} /lbs) ca. per 100	Multicoupling System Ordering Codes	Weight (^{kg} /lbs) ca. per 100
Female Thread according to DIN 3852-2-A - ANSI B 1.20.3							
	G3/8"	QRC-MK-R-10/4-FP-G06-BT-W3	682 1503.55	QRC-MK-R-10/4-MP-G06-BP-W3	334 736.34	QRC-MK-R-10/4-CC-G06-S1-W3	1016 2239.90
	G 1/2"	QRC-MK-R-10/4-FP-G08-BT-W3	680 1499.14	QRC-MK-R-10/4-MP-G08-BP-W3	332 731.93	QRC-MK-R-10/4-CC-G08-S1-W3	1012 2231.08
	NPTF 1/2" - 14	QRC-MK-R-10/4-FP-NF08-BT-W3	678 1494.73	QRC-MK-R-10/4-MP-NF08-BP-W3	330 727.53	QRC-MK-R-10/4-CC-NF08-S1-W3	1008 2222.26
Male Thread with 24° Conical Bore - Shape W according to DIN 3861							
	M16x1,5	10L QRC-MK-R-10/4-FP-10L-BT-W3	669 1474.89	QRC-MK-R-10/4-MP-10L-BP-W3	321 707.68	QRC-MK-R-10/4-CC-10L-S1-W3	990 2182.58
	M18x1,5	12L QRC-MK-R-10/4-FP-12L-BT-W3	669 1474.89	QRC-MK-R-10/4-MP-12L-BP-W3	321 707.68	QRC-MK-R-10/4-CC-12L-S1-W3	990 2182.58
	M22x1,5	15L QRC-MK-R-10/4-FP-15L-BT-W3	672 1481.51	QRC-MK-R-10/4-MP-15L-BP-W3	324 714.30	QRC-MK-R-10/4-CC-15L-S1-W3	996 2195.80
	M26x1,5	18L QRC-MK-R-10/4-FP-18L-BT-W3	674 1485.92	QRC-MK-R-10/4-MP-18L-BP-W3	326 718.71	QRC-MK-R-10/4-CC-18L-S1-W3	1000 2204.62

MK

Note: The connection of the two halves of a coupling is achieved depending on the type. It is important to observe the positive engagement of plug-type couplings and the secure tightening of screw-type couplings to the limit stop of the thread. Forced or improper separation will result in malfunction of the coupling.



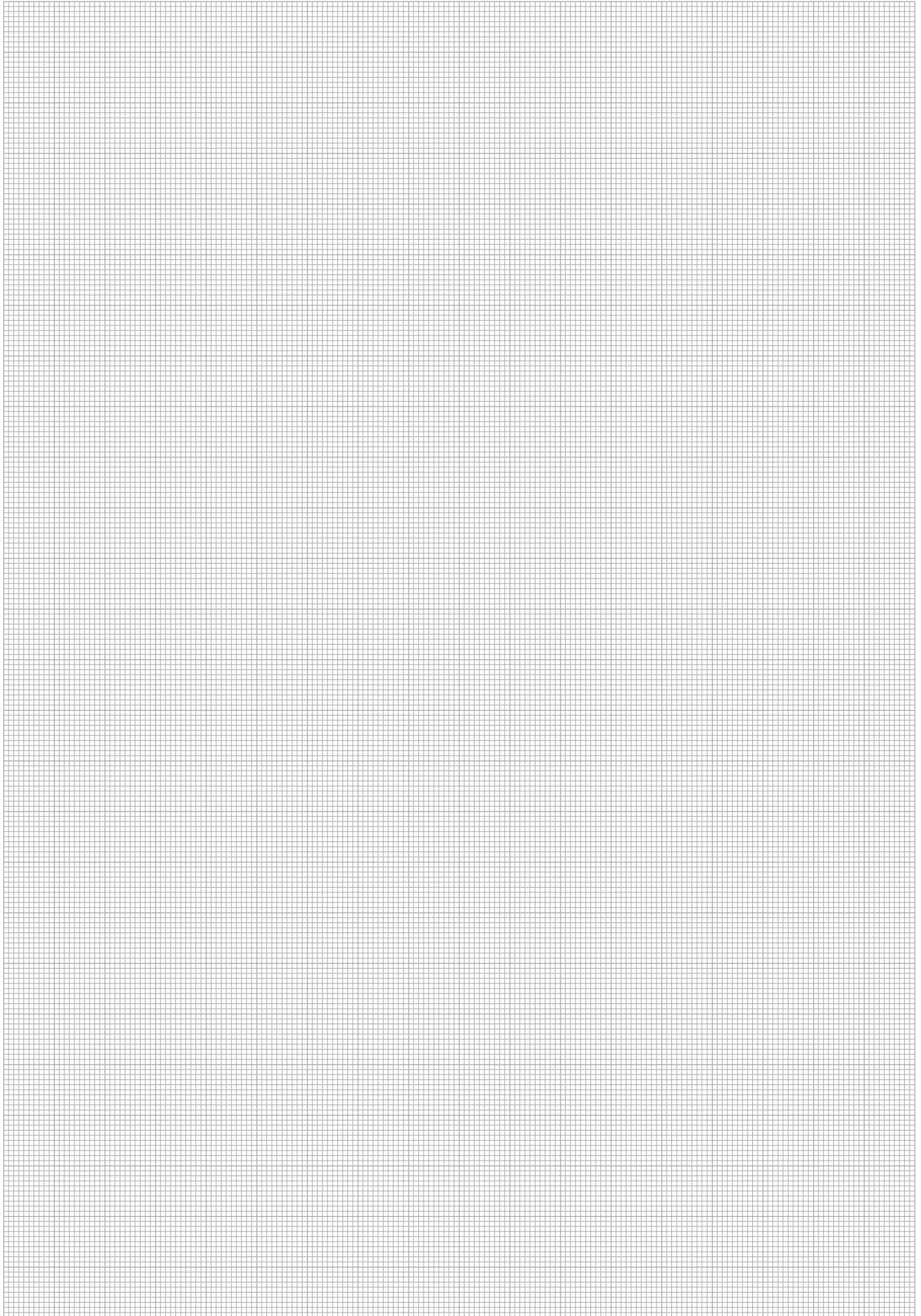

MK





Series HS • Carbon Steel
Product Description

Screw-to-connect couplings of the HS Series from STAUFF consist of a female body with external thread and a male tip with a screw sleeve. The Series is developed for particularly heavy-duty applications for connecting hydraulic lines up to DN38 (1-1/2").

Coupling (screwing) and uncoupling (unscrewing) of the two halves is safe and very easy. The coupling is designed to open both valves when connected together and due to their rugged design, higher operating and burst pressures, they are well suited for heavy-duty service conditions in construction machinery.

Features

- poppet valve
- Zinc-Plating and Thick-Film-Passivation (Chrome III)
- ISO Interchange acc. to ISO 14541
- Connectable up to 33% of working pressure with tools
- Self-locking connecting thread
- Feature: Black O-Ring
External O-ring as a safety feature to indicate the complete/correct connection of the male tip and female body (the O-ring must be covered by the sleeve of the female body)

The Series was developed according to ISO 14541 in the following nominal sizes 06, 10, 12, 16, 19, 25, 38 (1/4" - 1-1/2").

The proven design is suitable for use in heavy construction. Other applications include attachments or equipment using high pressure, high impulse hydraulics, e.g. hydraulic hammers.

Applications

Construction Machinery

Top Features

Vibration resistant



Designed for secure connection

HS



Series HS ▪ Carbon Steel

Material	Carbon Steel
Surface Finishing	Zinc-Plating and Thick-Film-Passivation (Chrome III)
Standard Seal Material(s)	NBR (Buna-N®) ²
Working Temperature	-25° C ... +100° C / -13° F ... +212° F
Valve Design	Poppet Valve
Connection	Screw
Disconnection	Screw
Connect Under Pressure	Male Tip/Female Body up to 33% of the Working Pressure with Tools
Application	Construction Machinery
ISO Interchange	ISO 14541 (BG 1-6)



² Alternative seal materials are available on request.

Technical Data

Series	BG	DN Zoll Inch	DN metric ISO 4397	Q _{max}		Working Pressure		Bursting Pressure Connected		Female Body		Male Tip		Spillage	
				l/min	US GPM	bar	PSI	bar	PSI	bar	PSI	bar	PSI	ml	fl oz
HS-06 ("...-HX")	1	1/4"	6,3	20	5.28	450	6527	1800	26107	1400	20305	1400	20305	0,8	.0271
HS-10	2	3/8"	10	35	9.25	450	6527	1600	23206	1750	25382	1550	22481	1,3	.0440
HS-12	3	1/2"	12,5	80	21.13	400	5802	1400	20305	1200	17405	1200	17405	3,1	.1048
HS-19	4	3/4"	19	120	31.70	400	5802	1500	21756	1600	23206	1200	17405	5,6	.1894
HS-25	6	1"	25	160	42.27	300	4351	1180	17114	1500	21756	1100	15954	12,3	.4159
HS-25-...-HX	6	1"	25	160	42.27	350	5076	1180	17114	1500	21756	1100	15954	12,3	.4159
HS-38	8	1 1/2"	38	220	58.12	350	5076	1800	26107	1600	23206	1200	17405	52,3	17.685

The indicated pressure ratings only apply to the coupling itself and depend on the connection type.

Flow Characteristics

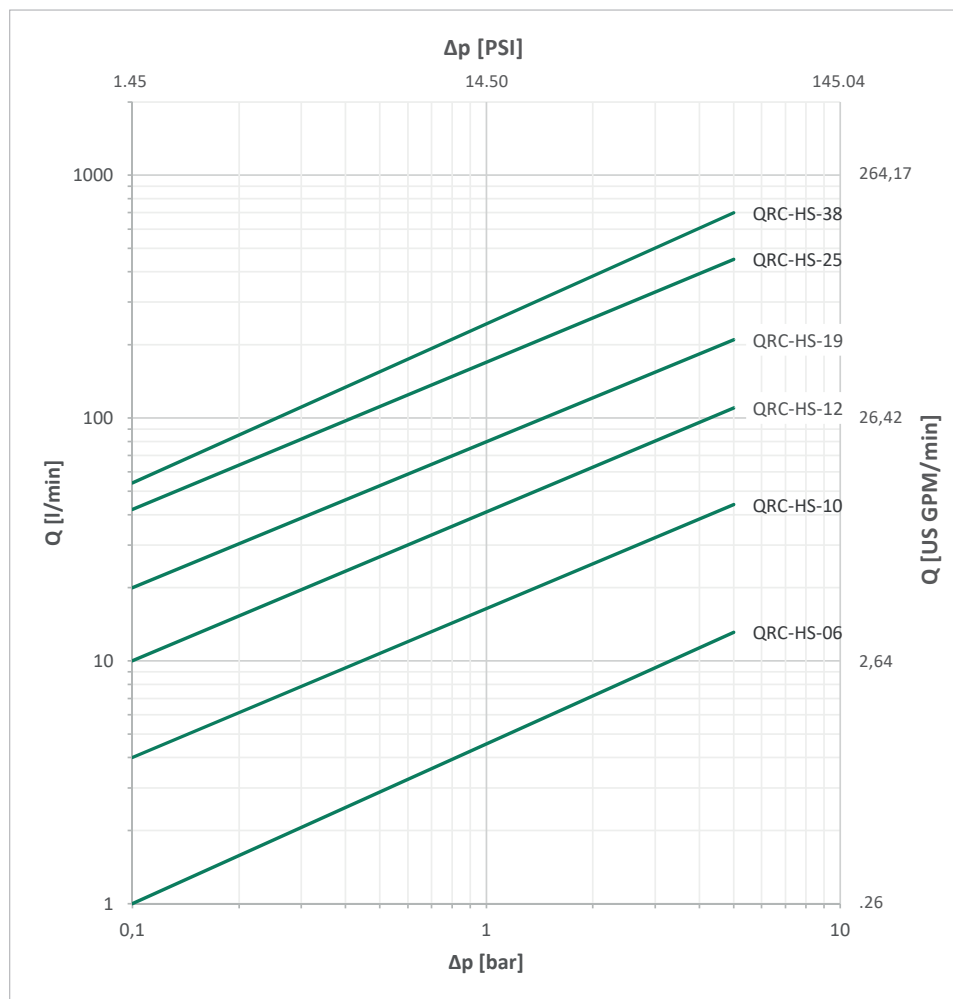

Please note: Unless otherwise stated, all flow characteristics have been determined with hydraulic oil with a kinematic viscosity of 28,8 - 35,2 mm²/s (28,8 - 35,2 cSt) and are only valid for components with non-reducing connections.

HS



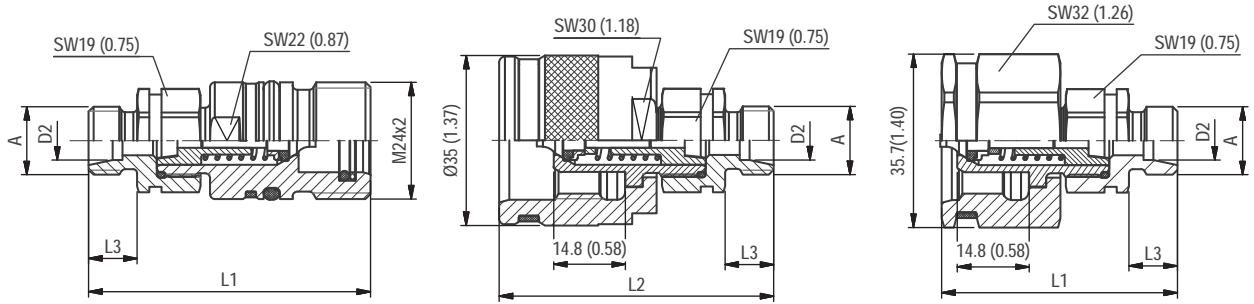

SW: Width across flats. All dimensions in mm (inch).

Series HS-06 ▪ BG 1 ▪ Nominal Size 6,3

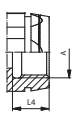
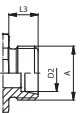
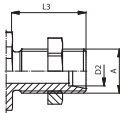
Port A	Dimensions (^{mm} / _{in})					Female Body Ordering Codes	Weight (^{kg} / _{lbs}) ca. per 100	Male Tip Ordering Codes	Weight (^{kg} / _{lbs}) ca. per 100
	ØD2	L1	L2	L3	L4				
Female Thread according to DIN 3852-2-A - ANSI B 1.20.3									
	G 1/4"	60 2.36	59 2.32		13 .51	QRC-HS-06-F-G04-BT-W66	12 26.46	QRC-HS-06-M-G04-BT-W66	18,20 40.12
	NPTF 1/4" -18	60 2.36	59 2.32				QRC-HS-06-F-NF04-BT-W66	12 26.46	QRC-HS-06-M-NF04-B-W66
Male Thread with 24° Conical Bore - Shape W according to DIN 3861									
	M14x1,5	8L	58 2.28	57 2.24	10 .39	QRC-HS-06-F-08L-BT-W66	12,10 26.68	QRC-HS-06-M-08L-B-W66	18,70 41.23
Male Thread with 24° Conical Bore - Bulkhead - Shape W according to DIN 3861									
	M14x1,5	8L	73 2.87	72 2.83	25 .98	QRC-HS-06-F-08LB-BT-W66	13,70 30.20	QRC-HS-06-M-08LB-B-W66	20,30 44.75

For the Version with Hexagonal Sleeve, please add "-HX" behind the Ordering Code.
Available on request with a safety clamp.

HS

Note: The connection of the two halves of a coupling is achieved depending on the type. It is important to observe the positive engagement of plug-type couplings and the secure tightening of screw-type couplings to the limit stop of the thread. Forced or improper separation will result in malfunction of the coupling.



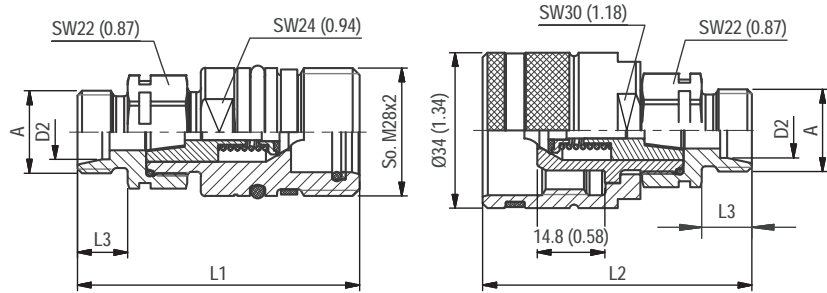

SW: Width across flats. All dimensions in mm (inch).

Series HS-10 • BG 2 • Nominal Size 10

Port A	Dimensions (^{mm} / _{in})					Female Body Ordering Codes	Weight (^{kg} / _{lbs}) ca. per 100	Male Tip Ordering Codes	Weight (^{kg} / _{lbs}) ca. per 100
	ØD2	L1	L2	L3	L4				
Male Thread according to DIN ISO 8434-1									
	G 3/8"	65	62	12		QRC-HS-10-F-B06-BT-W66	16,90 37.26	QRC-HS-10-M-B06-B-W66	18,10 39.90
	UNF 3/4" -16	67	53	17		QRC-HS-10-F-J08-BT-W66	16 35.27	QRC-HS-10-M-J08-B-W66	17,50 38.58
Female Thread according to DIN 3852-2-A - ISO 9974-1 - ANSI B 1.20.3									
	G1/4"	64	61		13	QRC-HS-10-F-G04-BT-W66	18 39.68	QRC-HS-10-M-G04-B-W66	19,20 42.33
		2.52	2.40		.51				
	G3/8"	64	61		13	QRC-HS-10-F-G06-BT-W66	17,20 37.92	QRC-HS-10-M-G06-B-W66	18,40 40.57
		2.52	2.40		.51				
M16x1,5	64	61		13	QRC-HS-10-F-M16-BT-W66	16,10 35.49	QRC-HS-10-M-M16-B-W66	17,40 38.36	
NPTF 3/8" -18	2.52	2.40		.51	QRC-HS-10-F-NF06-BT-W66	17,30 38.14	QRC-HS-10-M-NF06-B-W66	18,50 40.79	
Male Thread with 24° Conical Bore - Shape W according to DIN 3861									
	M14x1,5	8L	61	58	10	QRC-HS-10-F-08L-BT-W66	14,40 31.75	QRC-HS-10-M-08L-B-W66	15,80 34.83
		2.39	2.28	.39					
	M16x1,5	10L	62	59	11	QRC-HS-10-F-10L-BT-W66	15,80 34.83	QRC-HS-10-M-10L-B-W66	16,90 37.26
		2.43	2.32	.43					
	M18x1,5	12L	62	59	11	QRC-HS-10-F-12L-BT-W66	16 35.27	QRC-HS-10-M-12L-B-W66	17,20 37.92
		2.43	2.32	.43					
M16x1,5	8S	63	60	12	QRC-HS-10-F-08S-BT-W66	16,30 35.94	QRC-HS-10-M-08S-B-W66	17,40 38.36	
	2.47	2.36	.47						
M18x1,5	10S	63	60	12	QRC-HS-10-F-10S-BT-W66	16,40 36.16	QRC-HS-10-M-10S-B-W66	17,60 38.80	
	2.47	2.36	.47						
M20x1,5	12S	63	60	12	QRC-HS-10-F-12S-BT-W66	15,40 33.95	QRC-HS-10-M-12S-B-W66	17,90 39.46	
		2.47	2.36	.47					
Male Thread with 24° Conical Bore - Bulkhead - Shape W according to DIN 3861									
	M14x1,5	8L	76	73	25	QRC-HS-10-F-08LB-BT-W66	17,20 37.92	QRC-HS-10-M-08LB-B-W66	17,60 38.80
		2.98	2.87	.98					
	M16x1,5	10L	77	74	26	QRC-HS-10-F-10LB-BT-W66	18,70 41.23	QRC-HS-10-M-10LB-B-W66	17 37.48
		3.02	2.91	1.02					
	M22x1,5	15L	78	75	27	QRC-HS-10-F-15LB-BT-W66	23,10 50.93	QRC-HS-10-M-15LB-BT-W66	17,50 38.58
		3.06	2.95	1.06					
M16x1,5	08S	78	5	27	QRC-HS-10-F-08SB-BT-W66	16 35.27	QRC-HS-10-M-08SB-BT-W66	17 37.48	
	3.06	.20	1.06						
M18x1,5	10S	78	75	27	QRC-HS-10-F-10SB-BT-W66	17,50 38.58	QRC-HS-10-M-10SB-B-W66	17,50 38.58	
	3.06	2.95	1.06						
M20x1,5	12S	78	75	27	QRC-HS-10-F-12SB-BT-W66	31 68.34	QRC-HS-10-M-12SB-B-W66	17,10 37.70	
	3.06	2.95	1.06						

Available on request with a safety clamp and Hexagonal Sleeve.

Note: The connection of the two halves of a coupling is achieved depending on the type. It is important to observe the positive engagement of plug-type couplings and the secure tightening of screw-type couplings to the limit stop of the thread. Forced or improper separation will result in malfunction of the coupling.



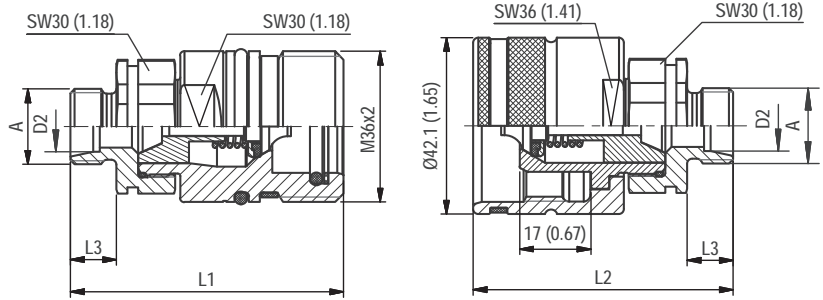

SW: Width across flats. All dimensions in mm (inch).

Series HS-12 ▪ BG 3 ▪ Nominal Size 12,5

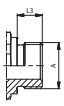
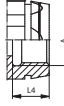
Port A	Dimensions (^{mm} / _{in})					Female Body Ordering Codes	Weight (^{kg} / _{lbs}) ca. per 100	Male Tip Ordering Codes	Weight (^{kg} / _{lbs}) ca. per 100
	ØD2	L1	L2	L3	L4				
Male Thread according to DIN 3852-2 - ISO 9974-3									
	G 3/8"	69 2.72	66 2.60	12 .47		QRC-HS-12-F-B06-BT-W66	28,70 63.27	QRC-HS-12-M-B06-B-W66	26,70 58.86
	G 1/2"	69 2.72	66 2.60	12 .47		QRC-HS-12-F-B08-BT-W66	29,50 65.04	QRC-HS-12-M-B08-B-W66	27,10 59.75
	M22x1,5	69 2.72	66 2.60	12 .47		QRC-HS-12-F-M22M-BT-W66	29,60 65.26	QRC-HS-12-M-M22M-B-W66	26,20 57.76
Female Thread according to DIN 3852-2-A - ISO 6149-1 - ANSI B 1.20.3 - SAE J1926-1 - ISO 11926-1									
	G3/8"	67 2.64	64 2.52		15 .59	QRC-HS-12-F-G06-BT-W66	30,80 67.90	QRC-HS-12-M-G06-B-W66	28,80 63.49
		G1/2"	67 2.64	64 2.52		15 .59	QRC-HS-12-F-G08-BT-W66	31,90 70.33	QRC-HS-12-M-G08-B-W66
	M18x1,5		67 2.64	64 2.52		15 .59	QRC-HS-12-F-M180R-BT-W66	30,20 66.58	QRC-HS-12-M-M180R-B-W66
		M22x1,5	67 2.64	64 2.52		15 .59	QRC-HS-12-F-M220R-BT-W66	29,20 64.37	QRC-HS-12-M-M220R-B-W66
	NPTF 1/2" -14		70 2.76	67 2.64			QRC-HS-12-F-NF08-BT-W66	29,60 65.26	QRC-HS-12-M-NF08-B-W66
	UNF 7/8" -14	73 2.87	70 2.76		18 .71	QRC-HS-12-F-U10-BT-W66	29,20 64.37	QRC-HS-12-M-U10-B-W66	27 59.52

Available on request with a safety clamp and Hexagonal Sleeve.

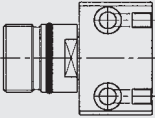
HS

The mating flange is also available for the screw-type carrier Type HS-12, size 1/2", 410 bar (6000 PSI).

Note: The connection of the two halves of a coupling is achieved depending on the type. It is important to observe the positive engagement of plug-type couplings and the secure tightening of screw-type couplings to the limit stop of the thread. Forced or improper separation will result in malfunction of the coupling.



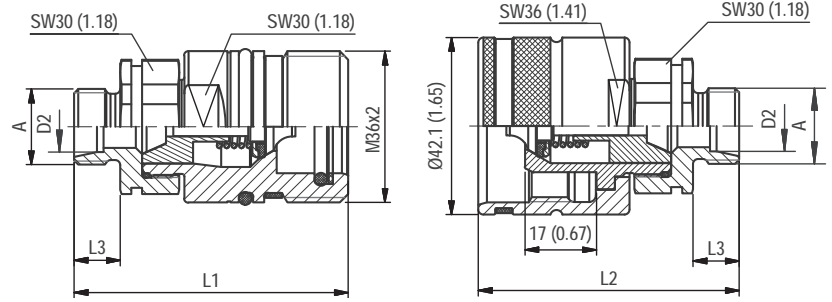

SW: Width across flats. All dimensions in mm (inch).

Series HS-12 • BG 3 • Nominal Size 12,5

	Port A	Dimensions (mm/in)				Female Body	Weight (kg/lbs) ca. per 100	Male Tip	Weight (kg/lbs) ca. per 100	
		ØD2	L1	L2	L3					L4
Male Thread with 24° Conical Bore - Shape W according to DIN 3861										
	M14x1,5	8L	64	61	10		QRC-HS-12-F-08L-BT-W66	26,40	QRC-HS-12-M-08L-B-W66	25,40
			2.53	2.40	.39			58.20	QRC-HS-12-M-08L-B-W66	56.00
	M16x1,5	10L	65	62	11		QRC-HS-12-F-10L-BT-W66	27,70	QRC-HS-12-M-10L-B-W66	25,70
			2.57	2.44	.43			61.07	QRC-HS-12-M-10L-B-W66	56.66
	M18x1,5	12L	65	62	11		QRC-HS-12-F-12L-BT-W66	27,80	QRC-HS-12-M-12L-B-W66	25,80
			2.57	2.44	.43			61.29	QRC-HS-12-M-12L-B-W66	56.88
	M22x1,5	15L	66	63	12		QRC-HS-12-F-15L-BT-W66	28,40	QRC-HS-12-M-15L-B-W66	26,40
			2.61	2.48	.47			62.61	QRC-HS-12-M-15L-B-W66	58.20
	M26x1,5	18L	66	63	12		QRC-HS-12-F-18L-BT-W66	28,40	QRC-HS-12-M-18L-B-W66	26,40
			2.61	2.48	.47			62.61	QRC-HS-12-M-18L-B-W66	58.20
M18x1,5	10S	66	63	12		QRC-HS-12-F-10S-BT-W66	28,40	QRC-HS-12-M-10S-B-W66	26,40	
		2.61	2.48	.47			62.61	QRC-HS-12-M-10S-B-W66	58.20	
M20x1,5	12S	66	63	12		QRC-HS-12-F-12S-BT-W66	28,40	QRC-HS-12-M-12S-B-W66	26,40	
		2.61	2.48	.47			62.61	QRC-HS-12-M-12S-B-W66	58.20	
M22x1,5	14S	68	65	14		QRC-HS-12-F-14S-BT-W66	29,20	QRC-HS-12-M-14S-B-W66	27,20	
		2.69	2.56	.55			64.37	QRC-HS-12-M-14S-B-W66	59.97	
M24x1,5	16S	68	65	14		QRC-HS-12-F-16S-BT-W66	29,20	QRC-HS-12-M-16S-B-W66	27,20	
		2.69	2.56	.55			64.37	QRC-HS-12-M-16S-B-W66	59.97	
M30x2	20S	70	67	16		QRC-HS-12-F-20S-BT-W66	28,40	QRC-HS-12-M-20S-B-W66	25,70	
		2.76	2.64	.63			62.61	QRC-HS-12-M-20S-B-W66	56.66	
Male Thread with 24° Conical Bore - Bulkhead - Shape W according to DIN 3861										
	M14x1,5	08L	80	77	26		QRC-HS-12-F-08LB-BT-W66	28,60	QRC-HS-12-M-08LB-B-W66	26,20
			3.16	3.03	1.02			63.05	QRC-HS-12-M-08LB-B-W66	57.76
	M16x1,5	10L	80	77	26		QRC-HS-12-F-10LB-BT-W66	30,70	QRC-HS-12-M-10LB-B-W66	27,50
			3.16	3.03	1.02			67.68	QRC-HS-12-M-10LB-B-W66	60.63
	M18x1,5	12L	84	81	30		QRC-HS-12-F-12LB-BT-W66	30,60	QRC-HS-12-M-12LB-B-W66	26,80
			3.31	3.19	1.18			67.46	QRC-HS-12-M-12LB-B-W66	59.08
	M22x1,5	15L	81	78	27		QRC-HS-12-F-15LB-BT-W66	31,40	QRC-HS-12-M-15LB-B-W66	28,20
			3.20	3.07	1.06			69.23	QRC-HS-12-M-15LB-B-W66	62.17
	M26x1,5	18L	81	78	27		QRC-HS-12-F-18LB-BT-W66	36,60	QRC-HS-12-M-18LB-B-W66	34,60
			3.20	3.07	1.06			80.69	QRC-HS-12-M-18LB-B-W66	76.28
M18x1,5	10S	80	77	26		QRC-HS-12-F-10SB-BT-W66	30,70	QRC-HS-12-M-10SB-B-W66	28	
		3.16	3.03	1.02			67.68	QRC-HS-12-M-10SB-B-W66	61.73	
M20x1,5	12S	81	78	27		QRC-HS-12-F-12SB-BT-W66	31,20	QRC-HS-12-M-12SB-B-W66	28,80	
		3.20	3.07	1.06			68.78	QRC-HS-12-M-12SB-B-W66	63.49	
M22x1,5	14S	83	80	29		QRC-HS-12-F-14SB-BT-W66	32,80	QRC-HS-12-M-14SB-B-W66	30,40	
		3.28	3.15	1.14			72.31	QRC-HS-12-M-14SB-B-W66	67.02	
M24x1,5	16S	83	80	29		QRC-HS-12-F-16SB-BT-W66	34,20	QRC-HS-12-M-16SB-B-W66	31,60	
		3.28	3.15	1.14			75.40	QRC-HS-12-M-16SB-B-W66	69.67	

Available on request with a safety clamp and Hexagonal Sleeve.

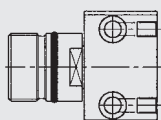

The mating flange is also available for the screw-type carrier Type HS-12, size 1/2", 410 bar (6000 PSI).

Note: The connection of the two halves of a coupling is achieved depending on the type. It is important to observe the positive engagement of plug-type couplings and the secure tightening of screw-type couplings to the limit stop of the thread. Forced or improper separation will result in malfunction of the coupling.



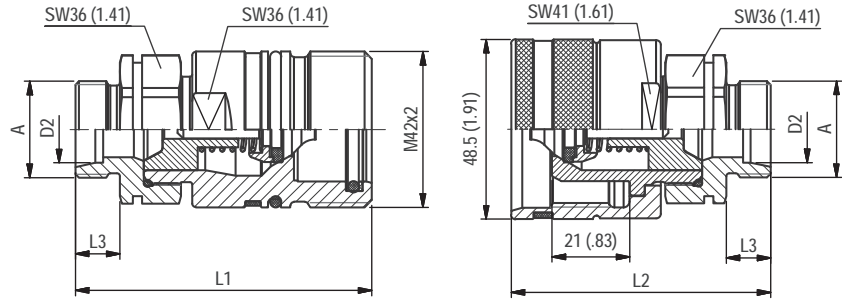

SW: Width across flats. All dimensions in mm (inch).

Series HS-19 • BG 4 • Nominal Size 19

Port A	Dimensions (mm/in)					Female Body Ordering Codes	Weight (^{kg} /lbs) ca. per 100	Male Tip Ordering Codes	Weight (^{kg} /lbs) ca. per 100
	ØD2	L1	L2	L3	L4				
Female Thread according to DIN 3852-2-A - ISO 9974-1 - ANSI B 1.20.3									
	G1/2"	86 3.39	75 2.95		19 .75	QRC-HS-19-F-G08-BT-W66	52,60 115.96	QRC-HS-19-M-G08-B-W66	50,40 111.11
	G3/4"	86 3.39	75 2.95		19 .75	QRC-HS-19-F-G12-BT-W66	63,60 140.21	QRC-HS-19-M-G12-B-W66	47,60 104.94
	M22x1,5	86 3.39	75 2.95		19 .75	QRC-HS-19-F-M22-BT-W66	55 121.25	QRC-HS-19-M-M22-B-W66	49 108.03
	NPTF 3/4" -14	86 3.39	75 2.95		19 .75	QRC-HS-19-F-NF12-BT-W66	55 121.25	QRC-HS-19-M-NF12-B-W66	47,60 104.94
Male Thread with 24° Conical Bore - Shape W according to DIN 3861									
	M18x1,5	12L	79 3.11	69 2.72	11 .43	QRC-HS-19-F-12L-BT-W66	46 101.41	QRC-HS-19-M-12L-B-W66	40,80 89.95
	M22x1,5	15L	80 3.15	70 2.76	12 .47	QRC-HS-19-F-15L-BT-W66	46,60 102.74	QRC-HS-19-M-15L-B-W66	41,30 91.05
	M26x1,5	18L	80 3.15	70 2.76	12 .47	QRC-HS-19-F-18L-BT-W66	47,90 105.60	QRC-HS-19-M-18L-B-W66	41,90 92.37
	M30x2	22L	82 3.23	72 2.83	14 .55	QRC-HS-19-F-22L-BT-W66	49,20 108.47	QRC-HS-19-M-22L-B-W66	43,10 95.02
	M24x1,5	16S	82 3.23	72 2.83	14 .55	QRC-HS-19-F-16S-BT-W66	47,40 104.50	QRC-HS-19-M-16S-B-W66	40,20 88.63
	M30x2	20S	84 3.31	74 2.91	16 .63	QRC-HS-19-F-20S-BT-W66	50 110.23	QRC-HS-19-M-20S-B-W66	44 97
Male Thread with 24° Conical Bore - Bulkhead - Shape W according to DIN 3861									
	M18x1,5	12L	94 3.70	84 3.31	26 1.02	QRC-HS-19-F-12LB-BT-W66	48,80 107.59	QRC-HS-19-M-12LB-B-W66	42,20 93.04
	M22x1,5	15L	95 3.74	85 3.35	27 1.06	QRC-HS-19-F-15LB-BT-W66	51 112.44	QRC-HS-19-M-15LB-B-W66	43,80 96.56
	M26x1,5	18L	95 3.74	85 3.35	27 1.06	QRC-HS-19-F-18LB-BT-W66	55,70 122.80	QRC-HS-19-M-18LB-B-W66	47,50 104.72
	M30x2	22L	104 4.09	94 3.70	36 1.42	QRC-HS-19-F-22LB-BT-W66	59,40 130.95	QRC-HS-19-M-22LB-B-W66	52,40 115.52
	M24x1,5	16S	97 3.82	87 3.43	29 1.14	QRC-HS-19-F-16SB-BT-W66	53,40 117.73	QRC-HS-19-M-16SB-B-W66	46,20 101.85
	M30x2	20S	104 4.09	94 3.70	36 1.42	QRC-HS-19-F-20SB-BT-W66	62,40 137.57	QRC-HS-19-M-20SB-B-W66	56,50 124.56

Available on request with a safety clamp and Hexagonal Sleeve.

HS

Note: The connection of the two halves of a coupling is achieved depending on the type. It is important to observe the positive engagement of plug-type couplings and the secure tightening of screw-type couplings to the limit stop of the thread. Forced or improper separation will result in malfunction of the coupling.



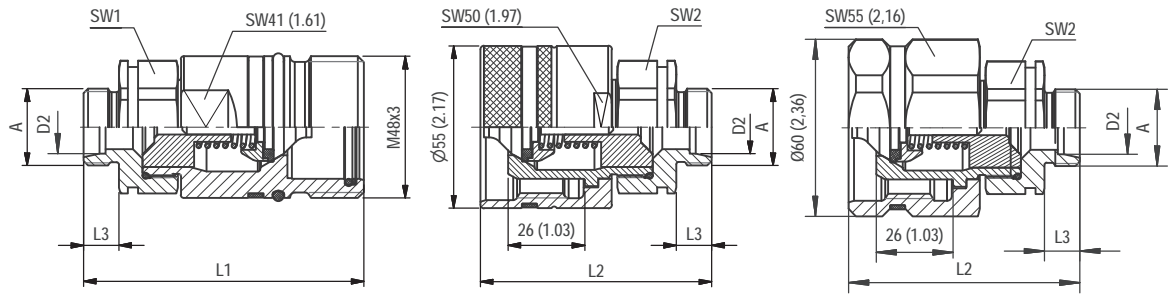

SW: Width across flats. All dimensions in mm (inch).

Series HS-25 • BG 6 • Nominal Size 25

Port A	Dimensions (^{mm/in})						Female Body Ordering Codes	Weight (^{kg/lbs}) ca. per 100	Male Tip Ordering Codes	Weight (^{kg/lbs}) ca. per 100		
	ØD2	L1	L2	L3	L4	SW1 SW2						
Female Thread according to DIN 3852-2-A - ANSI B 1.20.3												
	G3/4"	98	81		19	41	41	QRC-HS-25-F-G12-BT-W66	78,10 172.18	QRC-HS-25-M-G12-B-W66	68,80 151.68	
	G1"	98	81		19	41	41	QRC-HS-25-F-G16-BT-W66	73,80 162.70	QRC-HS-25-M-G16-B-W66	64,50 142.20	
	NPTF 1" -11 1/2	98	81			41	41	QRC-HS-25-F-NF16-BT-W66	78 171.96	QRC-HS-25-M-NF16-B-W66	60,10 132.50	
Male Thread with 24° Conical Bore - Shape W according to DIN 3861												
	M26x1,5	18L	95	78	12		41	41	QRC-HS-25-F-18L-BT-W66	70,90 156.31	QRC-HS-25-M-18L-B-W66	61,60 135.80
	M30x2	22L	97	80	14		41	41	QRC-HS-25-F-22L-BT-W66	71,50 157.63	QRC-HS-25-M-22L-B-W66	62,20 137.13
			3.82	3.15	.55		1.61	1.61				
	M36x2	28L	97	80	14		41	41	QRC-HS-25-F-28L-BT-W66	72 158.73	QRC-HS-25-M-28L-B-W66	67,20 148.15
			3.82	3.15	.55		1.61	1.61				
	M45x2	35L	99	82	16		46	46	QRC-HS-25-F-35L-BT-W66	80,50 177.47	QRC-HS-25-M-35L-B-W66	71,30 157.19
			3.90	3.23	.63		1.81	1.81				
	M30x2	20S	99	82	16		41	41	QRC-HS-25-F-20S-BT-W66	73,10 161.16	QRC-HS-25-M-20S-B-W66	63,90 140.88
3.90			3.23	.63		1.61	1.61					
M36x2	25S	101	84	18		41	41	QRC-HS-25-F-25S-BT-W66	75,30 166.01	QRC-HS-25-M-25S-B-W66	66 145.51	
		3.98	3.31	.71		1.61	1.61					
M42x2	30S	103	86	20		41	41	QRC-HS-25-F-30S-BT-W66	87,10 192.02	QRC-HS-25-M-30S-B-W66	65 143.30	
		4.06	3.39	.79		1.61	1.61					
M52x2	38S	105	88	22		55	55	QRC-HS-25-F-38S-BT-W66	108 238.10	QRC-HS-25-M-38S-B-W66	90,10 198.64	
		4.13	3.46	.87		2.17	2.17					
Male Thread with 24° Conical Bore - Bulkhead - Shape W according to DIN 3861												
	M22x1,5	15L	110	93	27		41	41	QRC-HS-25-F-15LB-BT-W66	82 180.78	QRC-HS-25-M-15LB-B-W66	62 136.69
			4.33	3.66	1.06		1.61	1.61				
	M26x1,5	18L	115	98	32		41	41	QRC-HS-25-F-18LB-BT-W66	76,60 168.87	QRC-HS-25-M-18LB-B-W66	63,80 140.65
			4.53	3.86	1.26		1.61	1.61				
	M30x2	22L	117	100	34		41	41	QRC-HS-25-F-22LB-BT-W66	86,10 189.82	QRC-HS-25-M-22LB-B-W66	65 143.30
			4.61	3.94	1.34		1.61	1.61				
	M36x2	28L	117	100	34		41	41	QRC-HS-25-F-28LB-BT-W66	89,90 198.20	QRC-HS-25-M-28LB-B-W66	69 152.12
			4.61	3.94	1.34		1.61	1.61				
	M30x2	20S	121	104	38		41	41	QRC-HS-25-F-20SB-BT-W66	94 207.23	QRC-HS-25-M-20SB-B-W66	70,60 155.65
4.76			4.09	1.50		1.61	1.61					
M36x2	25S	121	104	38		41	41	QRC-HS-25-F-25SB-BT-W66	94,70 208.78	QRC-HS-25-M-25SB-B-W66	74 163.14	
		4.76	4.09	1.50		1.61	1.61					
M42x2	30S	123	106	40		46	46	QRC-HS-25-F-30SB-BT-W66	104 229.28	QRC-HS-25-M-30SB-B-W66	85 187.39	
		4.84	4.17	1.57		1.81	1.81					
M52x2	38S	123	106	40		55	55	QRC-HS-25-F-38SB-BT-W66	140,40 309.53	QRC-HS-25-M-38SB-B-W66	85 187.39	
		4.84	4.17	1.57		2.17	2.17					

For the Version with Hexagonal Sleeve, please add "-HX" behind the Ordering Code. Available on request with a safety clamp.

Note: The connection of the two halves of a coupling is achieved depending on the type. It is important to observe the positive engagement of plug-type couplings and the secure tightening of screw-type couplings to the limit stop of the thread. Forced or improper separation will result in malfunction of the coupling.



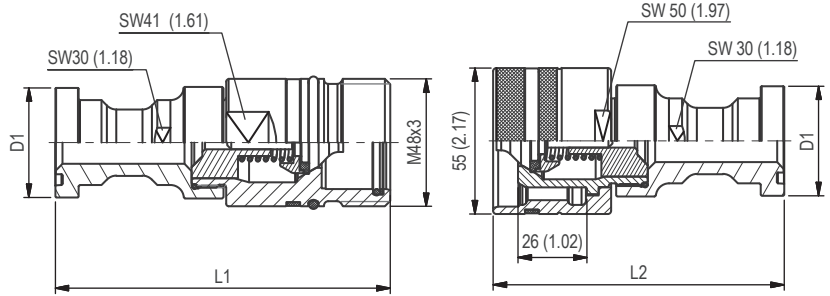

SW: Width across flats. All dimensions in mm (inch).

Series HS-25 ▪ BG 6 ▪ Nominal Size 25

Flange	Dimensions (^{mm} / _{in})						Female Body Ordering Codes	Weight (^{kg} / _{lbs}) ca. per 100	Male Tip Ordering Codes	Weight (^{kg} / _{lbs}) ca. per 100
	ØD1	L1	L2	L3	L4	L5				
3/4"	41,3	127 1.63	110 5.00				QRC-HS-25-F-F612-BT-W66	85,20 187.83	QRC-HS-25-M-F612-B-W66	76 167.55
1"	47,6	129 1.87	112 5.08				QRC-HS-25-F-F616-BT-W66	93,20 205.47	QRC-HS-25-M-F616-B-W66	83,90 184.97

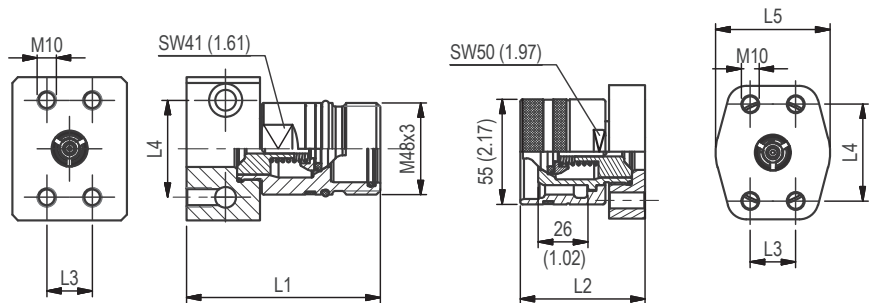

SW: Width across flats. All dimensions in mm (inch).

Flange	Dimensions (^{mm} / _{in})						Female Body Ordering Codes	Weight (^{kg} / _{lbs}) ca. per 100	Male Tip Ordering Codes	Weight (^{kg} / _{lbs}) ca. per 100
	ØD2	L1	L2	L3	L4	L5				
3/4"		102 4.02	65 2.56	23,8 .94	50,8 2.00	60 2.36	QRC-HS-25-F-C612M-B-W66-700514	163,10 359.57	QRC-HS-25-M-C612M-B-W66	87,70 193.35

HS

Note: The connection of the two halves of a coupling is achieved depending on the type. It is important to observe the positive engagement of plug-type couplings and the secure tightening of screw-type couplings to the limit stop of the thread. Forced or improper separation will result in malfunction of the coupling.



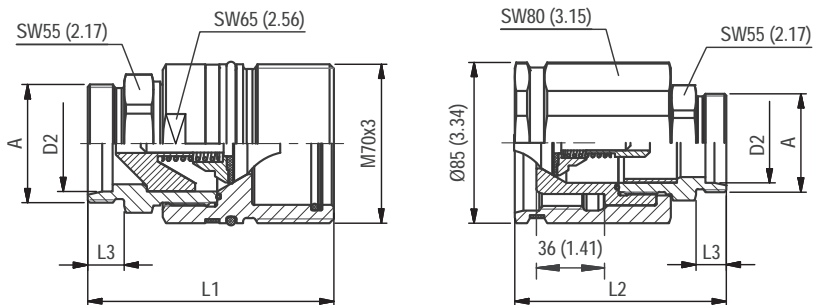

SW: Width across flats. All dimensions in mm (inch).

Series HS-38 • BG 8 • Nominal Size 38

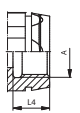
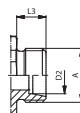
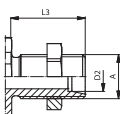
Port A	Dimensions (mm/in)					Female Body Ordering Codes	Weight (kg/lbs) ca. per 100	Male Tip Ordering Codes	Weight (kg/lbs) ca. per 100
	ØD2	L1	L2	L3	L4				
Female Thread according to DIN 3852-2-A / Innengewinde DIN 3852-2-A									
	G 1" 1/4	125 4.92	131 5.16		29 1.14	QRC-HS-38-F-G20-BT-W66	190,70 420.42	QRC-HS-38-M-G20-B-W66	276,60 609.80
	G 1" 1/2	127 5.00	134 5.28		31 1.22	QRC-HS-38-F-G24-BT-W66	184,90 407.63	QRC-HS-38-M-G24-B-W66	270,80 597.01
Male Thread with 24° Conical Bore - Shape W according to DIN 3861									
	M45x2	35L	105 4.11	112 4.39	16 .63	QRC-HS-38-F-35L-BT-W66	156 343.92	QRC-HS-38-M-35L-B-W66	209 460.77
	M52x2	42L	105 4.11	112 4.39	16 .63	QRC-HS-38-F-42L-BT-W66	162 357.15	QRC-HS-38-M-42L-B-W66	215 473.99
	M42x2	30S	112 4.41	119 4.69	20 .79	QRC-HS-38-F-30S-BT-W66	157,20 346.57	QRC-HS-38-M-30S-B-W66	209,20 461.21
	M52x2	38S	112 4.41	118 4.65	22 .87	QRC-HS-38-F-38S-BT-W66	162,40 358.03	QRC-HS-38-M-38S-B-W66	215,30 474.66
Male Thread with 24° Conical Bore - Bulkhead - Shape W according to DIN 3861									
	M45x2	35L	125 4.90	132 5.18	36 1.42	QRC-HS-38-F-35LB-BT-W66	173 381.40	QRC-HS-38-M-35LB-B-W66	234 515.88
	M52x2	42L	129 5.08	132 5.20	36 1.42	QRC-HS-38-F-42LB-BT-W66	172,50 380.30	QRC-HS-38-M-42LB-B-W66	233,50 514.78
	M42x2	30S	133 5.24	140 5.51	40 1.57	QRC-HS-38-F-30SB-BT-W66	182,40 402.12	QRC-HS-38-M-30SB-B-W66	268,30 591.50
	M52x2	38S	132 5.20	139 5.47	40 1.57	QRC-HS-38-F-38SB-BT-W66	173 381.40	QRC-HS-38-M-38SB-B-W66	279,30 615.75

Available on request with a safety clamp.

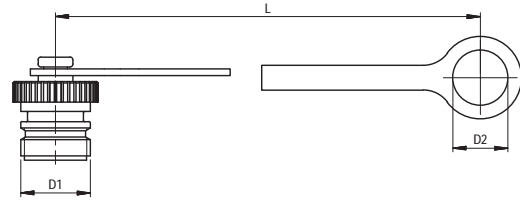
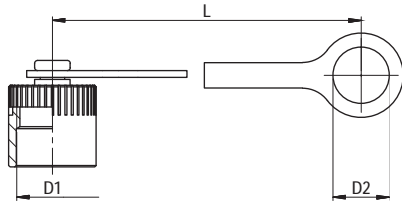

Series HS - Dust Protection

Dimensions (mm/in)			Material	Dust Cap for Female Body
D1	D2	L		Ordering Codes
M24x2	19 .75	180 7.09	Plastic (Colour: Red)	QRC-HS-06-DF-19-K-RD
M28x2	23 .91	180 7.09	Plastic (Colour: Red)	QRC-HS-10-DF-23-K-RD
M36x2	29,5 1.16	185 7.28	Plastic (Colour: Red)	QRC-HS-12-DF-30-K-RD
M42x2	36,5 1.44	190 7.48	Plastic (Colour: Red)	QRC-HS-19-DF-37-K-RD
M48x3	41 1.61	190 7.48	Plastic (Colour: Red)	QRC-HS-25-DF-41-K-RD
M70x3	55 2.17	201 7.91	Plastic (Colour: Red)	QRC-HS-38-DF-55-K-RD

Dimensions (mm/in)			Material	Dust Plug for Male Tip
D1	D2	L		Ordering Codes
M24x2	19 .75	180 7.09	Plastic (Colour: Red)	QRC-HS-06-DM-19-K-RD
M28x2	23 .91	180 7.09	Plastic (Colour: Red)	QRC-HS-10-DM-23-K-RD
M36x2	29,5 1.16	185 7.28	Plastic (Colour: Red)	QRC-HS-12-DM-30-K-RD
M42x2	36,5 1.44	190 7.48	Plastic (Colour: Red)	QRC-HS-19-DM-37-K-RD
M48x3	41 1.61	190 7.48	Plastic (Colour: Red)	QRC-HS-25-DM-41-K-RD
M70x3	55 2.17	201 7.91	Plastic (Colour: Red)	QRC-HS-38-DM-55-K-RD

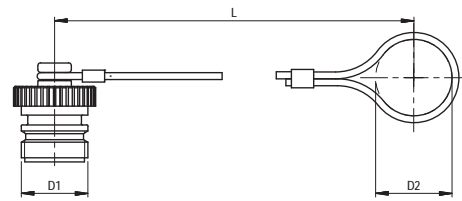
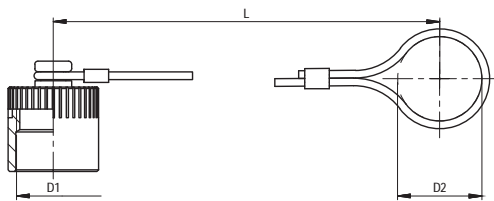

Dimensions (mm/in)			Material	Dust Cap for Female Body
D1	D2	L		Ordering Codes
M24x2			Aluminium with steel cable	QRC-HS-06-DF-19-W89-SI
M28x2			Aluminium with steel cable	QRC-HS-10-DF-23-W89-SI
M36x2			Aluminium with steel cable	QRC-HS-12-DF-30-W89-SI
M42x2			Aluminium with steel cable	QRC-HS-19-DF-37-W89-SI
M48x3			Aluminium with steel cable	QRC-HS-25-DF-41-W89-SI
M70x3			Aluminium with steel cable	QRC-HS-38-DF-55-W89-SI

Dimensions (mm/in)			Material	Dust Plug for Male Tip
D1	D2	L		Ordering Codes
M24x2			Aluminium with steel cable	QRC-HS-06-DM-19-W89-SI
M28x2			Aluminium with steel cable	QRC-HS-10-DM-23-W89-SI
M36x2			Aluminium with steel cable	QRC-HS-12-DM-30-W89-SI
M42x2			Aluminium with steel cable	QRC-HS-19-DM-37-W89-SI
M48x3			Aluminium with steel cable	QRC-HS-25-DM-41-W89-SI
M70x3			Aluminium with steel cable	QRC-HS-38-DM-55-W89-SI

In addition to the standard colours as stated above, plastic dust caps are also available in blue, green, yellow and black. Please use the color codes BU, GN, YE and BK respectively instead of RD.

HS

Note: The connection of the two halves of a coupling is achieved depending on the type. It is important to observe the positive engagement of plug-type couplings and the secure tightening of screw-type couplings to the limit stop of the thread. Forced or improper separation will result in malfunction of the coupling.



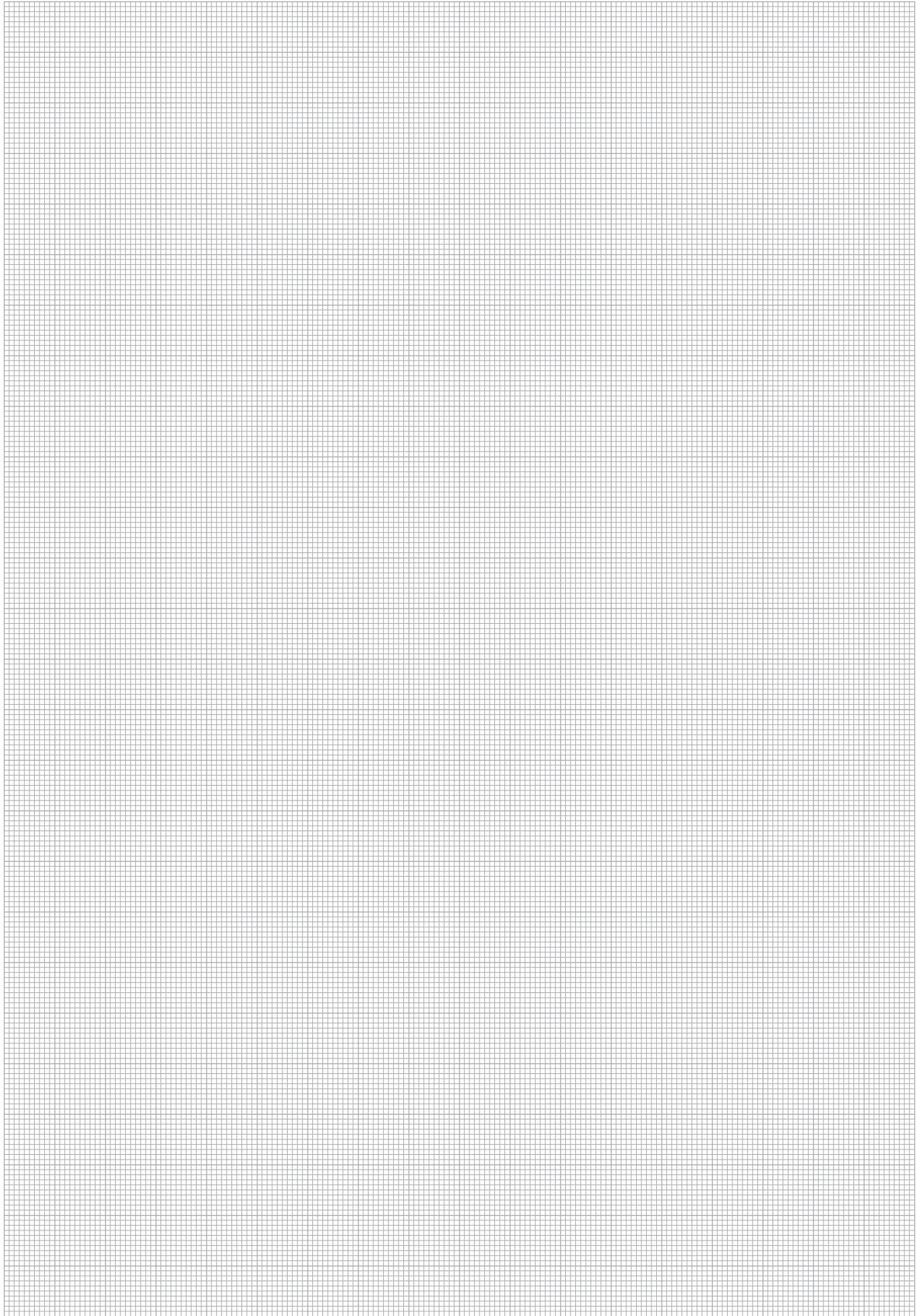

HS



Series HS • Stainless Steel
Product Description

Screw-to-connect couplings of the HS Series made of stainless steel from STAUFF consist of a female body with external thread and a male tip with a screw sleeve. The Series is developed for particularly heavy-duty applications for connecting hydraulic lines up to DN38 (1-1/2").

Coupling (screwing) and uncoupling (unscrewing) of the two halves is safe and very easy. The coupling is designed to open both valves when connected together and due to their rugged design, higher operating and burst pressures, they are well suited for heavy-duty service conditions in construction machinery.

The Series was developed according to ISO 14541 in the following nominal sizes 06, 10, 12, 19, 25, 38 (1/4" - 1-1/2").

The proven design is suitable for use in heavy construction. Other applications include attachments or equipment using high pressure, high impulse hydraulics, e.g. hydraulic hammers.

Features

- poppet valve
- Coupling made of stainless steel
- ISO Interchange acc. to ISO 14541
- Connectable up to 33% of working pressure with tools
- Self-locking connecting thread
- Feature: Black O-Ring
External O-ring as a safety feature to indicate the complete/correct connection of the male tip and female body (the O-ring must be covered by the sleeve of the female body)

Applications

Agricultural and Forestry Machinery



Construction Machinery



Industrial Hydraulic

Top Features

Vibration resistant



Designed for secure connection

HS



Series HS ▪ Stainless Steel

Material	Stainless Steel V4A (AISI 316)
Surface Finishing	-
Standard Seal Material(s)	FKM (Viton®) ²
Working Temperature	-25° C ... +200° C / -13° F ... +392° F
Valve Design	Poppet Valve
Connection	Screw
Disconnection	Screw
Connect Under Pressure	Male Tip/Female Body up to 33% of the Working Pressure with Tools
Application	Agricultural and Forestry Machinery, Construction Machinery, Industrial Hydraulic
ISO Interchange	ISO 14541 (BG 1-6)



² Alternative seal materials are available on request.

Technical Data

Series	BG	DN Zoll Inch	DN metric ISO 4397	Q _{max}		Working Pressure		Bursting Pressure Connected		Female Body		Male Tip		Spillage	
				l/min	US GPM	bar	PSI	bar	PSI	bar	PSI	bar	PSI	ml	fl oz
HS-06	1	1/4"	6,3	17	4.49	300	4351	1200	17405	1200	17405	1200	17405	0,8	.0271
HS-10	2	3/8"	10	30	7.93	250	3626	2400	34809	1600	23206	1450	21031	1,9	.0642
HS-12	3	1/2"	12,5	80	21.13	250	3626	2150	31183	1420	20595	1350	19580	2,7	.0913
HS-19	4	3/4"	19 (20)	190	50.19	150	2176	1400	20305	1100	15954	700	10153	9,3	.3145
HS-25	6	1"	25	280	73.97	150	2176	1350	19580	1100	15954	800	11603	16	.5410
HS-38	8	1 1/2"	38	350	92.46	100	1450	400	5802	400	5802	400	5802	30	10.144

The indicated pressure ratings only apply to the coupling itself and depend on the connection type.

Flow Characteristics

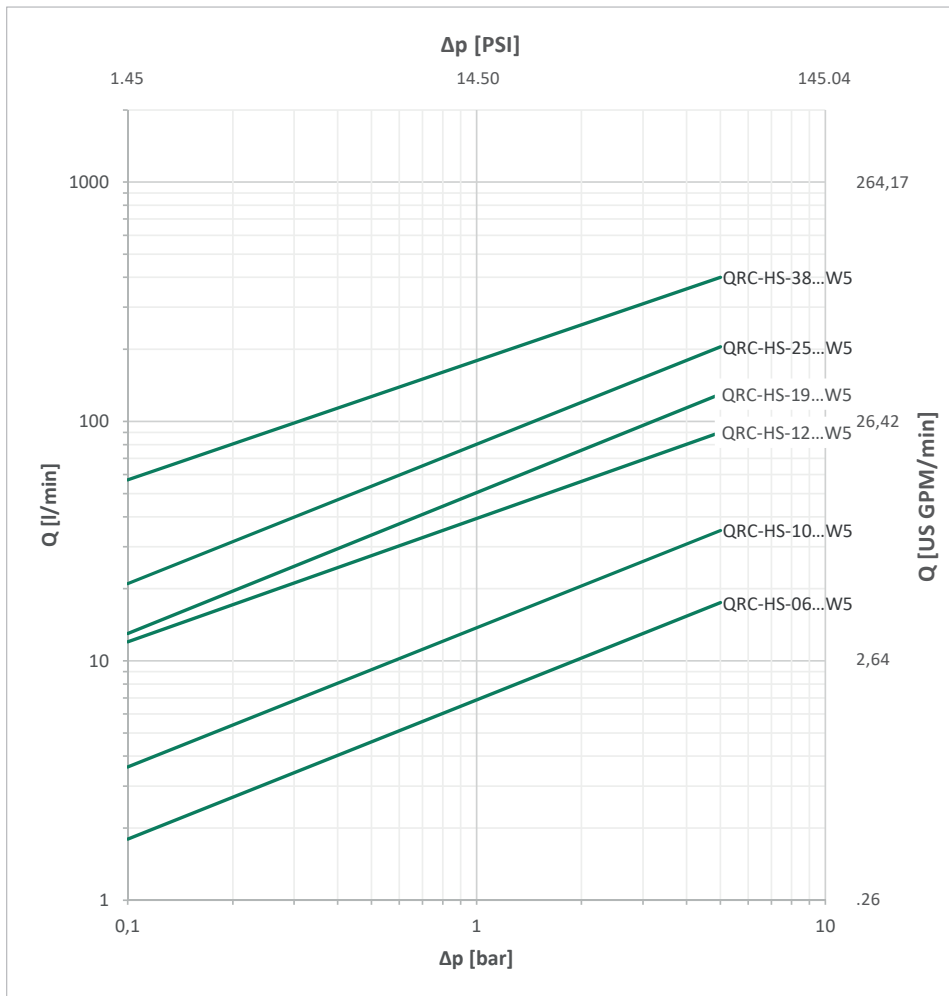

Please note: Unless otherwise stated, all flow characteristics have been determined with hydraulic oil with a kinematic viscosity of 28,8 - 35,2 mm²/s (28,8 - 35,2 cSt) and are only valid for components with non-reducing connections.



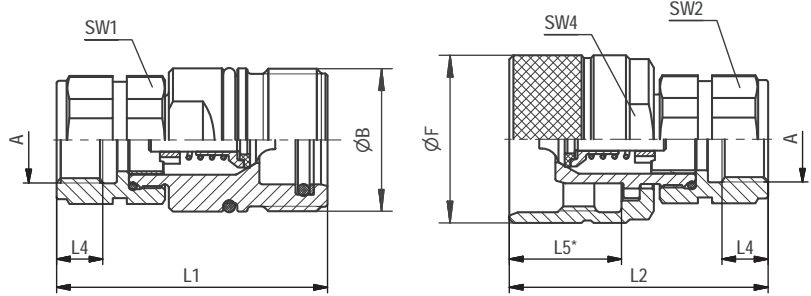

SW: Width across flats. All dimensions in mm (inch). Drawing similar Series HS-12.
* Insertion Female Body.

Series HS-06 ▪ BG 1 ▪ Nominal Size 6,3

Port A	Dimensions (mm/in)	Female Body									Weight (^{kg} /lbs) ca. per 100	Male Tip Ordering Codes	Weight (^{kg} /lbs) ca. per 100	
		ØB	ØF	L1	L2	L4 min	L5	SW1	SW2	SW4				Ordering Codes
Female Thread according to DIN 3852 - ISO 1179-1														
	G 1/4"	M24x2	30	59,1	58	12	25,1	19	19	27	QRC-HS-06-F-G04-VT-W5	12,20 26.90	QRC-HS-06-M-G04-V-W5	13 28.66
			1.18	2.33	2.28	.47	.99	.75	.75	1.06				

Series HS-10 ▪ BG 2 ▪ Nominal Size 10

Port A	Dimensions (mm/in)	Female Body									Weight (^{kg} /lbs) ca. per 100	Male Tip Ordering Codes	Weight (^{kg} /lbs) ca. per 100	
		ØB	ØF	L1	L2	L4 min	L5	SW1	SW2	SW4				Ordering Codes
Female Thread according to DIN 3852 - ISO 1179-1														
	G 3/8"	M28x2	34	64,5	62	12	26,5	22	22	30	QRC-HS-10-F-G06-VT-W5	16,30 35.94	QRC-HS-10-M-G06-V-W5	17,40 38.36
			1.34	2.54	2.44	.47	1.04	.87	.87	1.18				

Series HS-12 ▪ BG 3 ▪ Nominal Size 12,5

Port A	Dimensions (mm/in)	Female Body									Weight (^{kg} /lbs) ca. per 100	Male Tip Ordering Codes	Weight (^{kg} /lbs) ca. per 100	
		ØB	ØF	L1	L2	L4 min	L5	SW1	SW2	SW4				Ordering Codes
Female Thread according to DIN 3852 - ISO 1179-1														
	G 3/8"	M36x2	41,8	67	63	12	28	30	30	38	QRC-HS-12-F-G06-VT-W5	33,10 72.97	QRC-HS-12-M-G06-V-W5	30,50 67.24
			1.64	2.64	2.48	.47	1.1	1.18	1.18	1.49				
	G 1/2"	M36x2	41,8	67	63	12	28	30	30	38	QRC-HS-12-F-G08-VT-W5	31,20 68.78	QRC-HS-12-M-G08-V-W5	28,10 61.95
			1.64	2.64	2.48	.47	1.1	1.18	1.18	1.49				

Series HS-19 ▪ BG 4 ▪ Nominal Size 19

Port A	Dimensions (mm/in)	Female Body									Weight (^{kg} /lbs) ca. per 100	Male Tip Ordering Codes	Weight (^{kg} /lbs) ca. per 100	
		ØB	ØF	L1	L2	L4 min	L5	SW1	SW2	SW4				Ordering Codes
Female Thread according to DIN 3852 - ISO 1179-1														
	G 3/4"	M42x2	48	82	75	16	21	36	36	41	QRC-HS-19-F-G12-VT-W5	51,10 112.66	QRC-HS-19-M-G12-V-W5	44,10 97.22
			1.89	3.23	2.95	.63	.83	1.42	1.42	1.61				

Note: The connection of the two halves of a coupling is achieved depending on the type. It is important to observe the positive engagement of plug-type couplings and the secure tightening of screw-type couplings to the limit stop of the thread. Forced or improper separation will result in malfunction of the coupling.



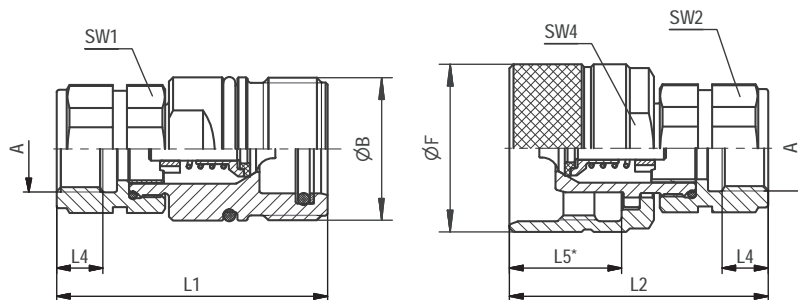

SW: Width across flats. All dimensions in mm (inch). Drawing similar Series HS-12.
* Insertion Female Body.

Series HS-25 • BG 6 • Nominal Size 25

Port A	Dimensions (mm/in)										Female Body Ordering Codes	Weight (^{kg} / _{lbs}) ca. per 100	Male Tip Ordering Codes	Weight (^{kg} / _{lbs}) ca. per 100
	ØB	ØF	L1	L2	L4 min	L5	SW1	SW2	SW4					
Female Thread according to DIN 3852 - ISO 1179-1														
 G 3/4"	M48x3	55	95	78,5	16		35,5	41	16	50	QRC-HS-25-F-G12-VT-W5	74,80	QRC-HS-25-M-G12-V-W5	65,10
		2.16	3.74	3.09	.63		1.40	1.61	.63	1.97		164.91		143.52
 G 1"	M48x3	55	95	78,5	18		35,5	41	18	50	QRC-HS-25-F-G16-VT-W5	71,30	QRC-HS-25-M-G16-V-W5	61,50
		2.16	3.74	3.09	.71		1.40	1.61	.71	1.97		157.19		135.58

Series HS-38 • BG 8 • Nominal Size 38

Port A	Dimensions (mm/in)										Female Body Ordering Codes	Weight (^{kg} / _{lbs}) ca. per 100	Male Tip Ordering Codes	Weight (^{kg} / _{lbs}) ca. per 100
	ØB	ØF	L1	L2	L4 min	L5	SW1	SW2	SW4					
Female Thread according to DIN 3852 - ISO 1179-1														
 G 1 1/4"	M70x3	80	116	121	20		44	60	20	65	QRC-HS-38-F-G20-VT-W5	180,20	QRC-HS-38-M-G20-V-W5	235
		3.12	4.57	4.76	.79		1.73	2.36	.79	2.56		397.27		518.09
 G 1 1/2"	M70x3	80	116	121	22		44	60	22	65	QRC-HS-38-F-G24-VT-W5	173	QRC-HS-38-M-G24-V-W5	227,80
		3.12	4.57	4.76	.87		1.73	2.36	.87	2.56		381.40		502,21

HS

Note: The connection of the two halves of a coupling is achieved depending on the type. It is important to observe the positive engagement of plug-type couplings and the secure tightening of screw-type couplings to the limit stop of the thread. Forced or improper separation will result in malfunction of the coupling.

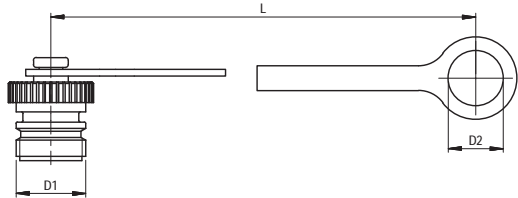
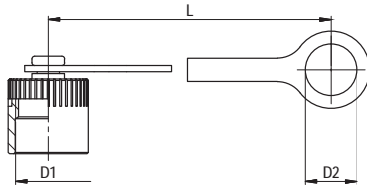

Series HS • Dust Protection

Dimensions (mm/in)			Material	Dust Cap for Female Body
D1	D2	L		Ordering Codes
M24x2	19 .75	180 7.09	Plastic (Colour: Red)	QRC-HS-06-DF-19-K-RD
M28x2	23 .91	180 7.09	Plastic (Colour: Red)	QRC-HS-10-DF-23-K-RD
M36x2	29,5 1.16	185 7.28	Plastic (Colour: Red)	QRC-HS-12-DF-30-K-RD
M42x2	36,5 1.44	190 7.48	Plastic (Colour: Red)	QRC-HS-19-DF-37-K-RD
M48x3	41 1.61	190 7.48	Plastic (Colour: Red)	QRC-HS-25-DF-41-K-RD
M70x3	55 2.17	201 7.91	Plastic (Colour: Red)	QRC-HS-38-DF-55-K-RD

Dimensions (mm/in)			Material	Dust Plug for Male Tip
D1	D2	L		Ordering Codes
M24x2	19 .75	180 7.09	Plastic (Colour: Red)	QRC-HS-06-DM-19-K-RD
M28x2	23 .91	180 7.09	Plastic (Colour: Red)	QRC-HS-10-DM-23-K-RD
M36x2	29,5 1.16	185 7.28	Plastic (Colour: Red)	QRC-HS-12-DM-30-K-RD
M42x2	36,5 1.44	190 7.48	Plastic (Colour: Red)	QRC-HS-19-DM-37-K-RD
M48x3	41 1.61	190 7.48	Plastic (Colour: Red)	QRC-HS-25-DM-41-K-RD
M70x3	55 2.17	201 7.91	Plastic (Colour: Red)	QRC-HS-38-DM-55-K-RD

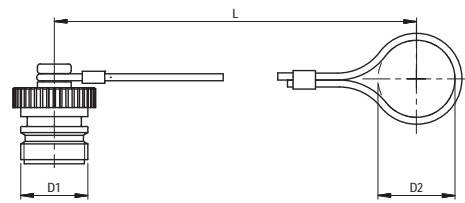
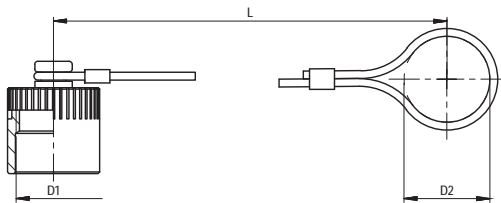

Dimensions (mm/in)			Material	Dust Cap for Female Body
D1	D2	L		Ordering Codes
M24x2			Aluminium with steel cable	QRC-HS-06-DF-19-W89-SI
M28x2			Aluminium with steel cable	QRC-HS-10-DF-23-W89-SI
M36x2			Aluminium with steel cable	QRC-HS-12-DF-30-W89-SI
M42x2			Aluminium with steel cable	QRC-HS-19-DF-37-W89-SI
M48x3			Aluminium with steel cable	QRC-HS-25-DF-41-W89-SI
M70x3			Aluminium with steel cable	QRC-HS-38-DF-55-W89-SI

Dimensions (mm/in)			Material	Dust Plug for Male Tip
D1	D2	L		Ordering Codes
M24x2			Aluminium with steel cable	QRC-HS-06-DM-19-W89-SI
M28x2			Aluminium with steel cable	QRC-HS-10-DM-23-W89-SI
M36x2			Aluminium with steel cable	QRC-HS-12-DM-30-W89-SI
M42x2			Aluminium with steel cable	QRC-HS-19-DM-37-W89-SI
M48x3			Aluminium with steel cable	QRC-HS-25-DM-41-W89-SI
M70x3			Aluminium with steel cable	QRC-HS-38-DM-55-W89-SI

In addition to the standard colours as stated above, plastic dust caps are also available in blue, green, yellow and black. Please use the color codes BU, GN, YE and BK respectively instead of RD.

HS



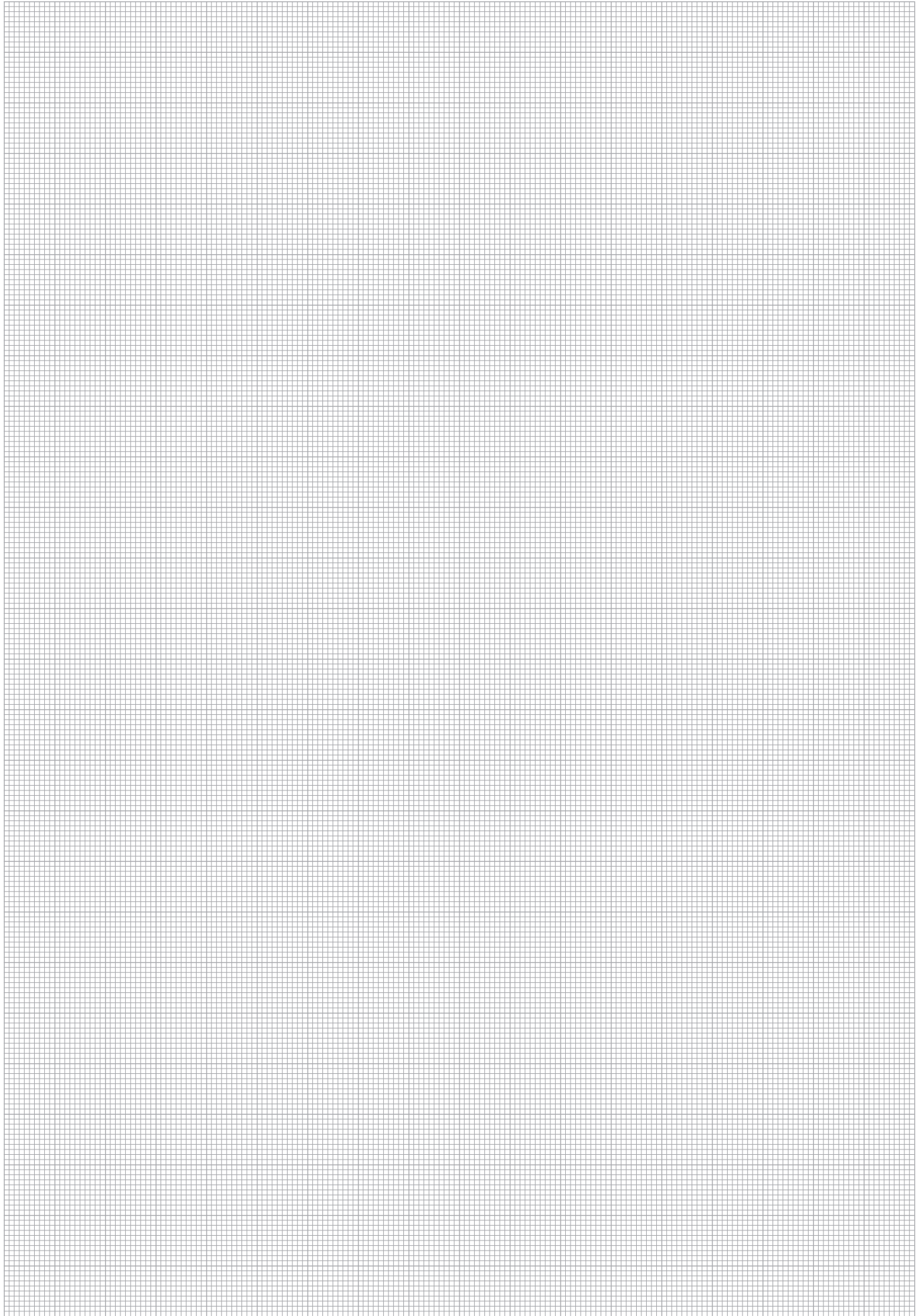

HS



Series PS • Carbon Steel
Product Description

Screw-to-connect couplings of the PS Series from STAUFF consist of a female body with external thread and a male tip with a screw sleeve. The Series is developed for particularly heavy-duty hammer applications and for connection of different booms in High Reach Demolition machines for connecting hydraulic lines in DN25 (1").

Coupling (screwing) and uncoupling (unscrewing) of the two halves is safe and very easy. After the connection is complete, all internal components have minimal play or clearance, which significantly reduces the risk of material fatigue.

Another advantage is that the risk of permanent indentation, so-called "brinelling", on the surface of the male tip is eliminated, which can occur with push-to-connect couplings in similar extreme applications.

Features

- poppet valve
- Coupling made from carbon steel with Zinc/Nickel surface coating
- Sealing's made from FKM (Viton®), HNBR, PTFE
- Patented poppet valve unit with fully enclosed/chambered sealings eliminating the risk of extrusion faults
- Bi-directional flow
- Can be connected at 50 bar maximum residual pressure (tools required)

The permitted working pressures of the series PS coupling is comparatively higher, and with a safety factor of 4x working pressure, maximum flow rate of 600 l/min (or up to 1000 l/min for short term period) and able to withstand, high oil flow rates, intense pressure impulses, extreme vibrations and severe operating and environmental (site) conditions.

The PS Series is available in nominal size 25 (1").

Applications

Construction Machinery

Top Features

Zinc/Nickel coating



Vibration resistant



Designed for secure connection

PS



Series PS ▪ Carbon Steel

Material	Carbon Steel
Surface Finishing	Zinc-Nickel
Standard Seal Material(s)	HNBR, FKM (Viton®), PTFE ²
Working Temperature	-20° C ... +150° C / -4° F ... +302° F
Valve Design	Poppet Valve
Connection	Screw
Disconnection	Screw
Connect Under Pressure	not allowed
Application	Construction Machinery
ISO Interchange	-



² Alternative seal materials are available on request.

Technical Data

Series	BG	DN Zoll Inch	DN metric ISO 4397	Q _{max}		Working Pressure		Bursting Pressure Connected		Female Body		Male Tip		Spillage	
				l/min	US GPM	bar	PSI	bar	PSI	bar	PSI	bar	PSI	ml	fl oz
PS-25	08	1"	25	600 (1000)*	158.50	380	5511	1520	22046	1520	22046	1520	22046	27	.9130

The indicated pressure ratings only apply to the coupling itself and depend on the connection type.
 * short term possible

Flow Characteristics

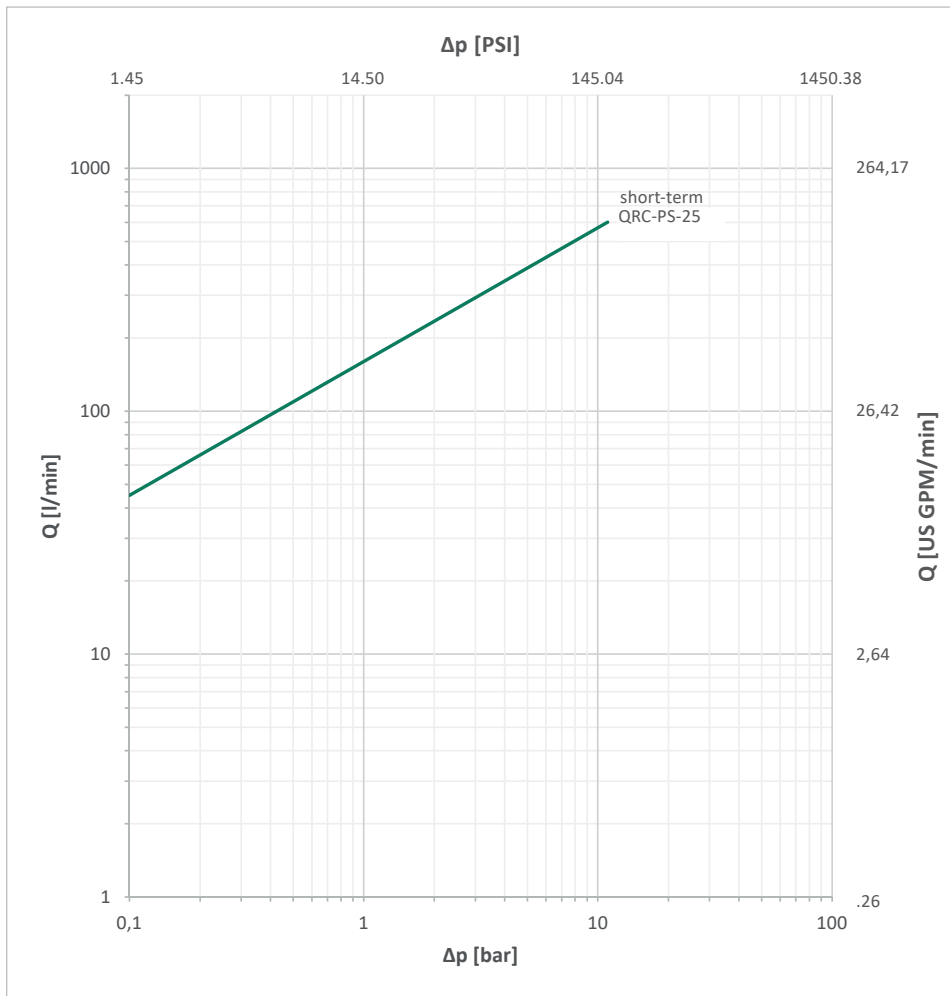

Please note: Unless otherwise stated, all flow characteristics have been determined with hydraulic oil with a kinematic viscosity of 28,8 - 35,2 mm²/s (28,8 - 35,2 cSt) and are only valid for components with non-reducing connections.



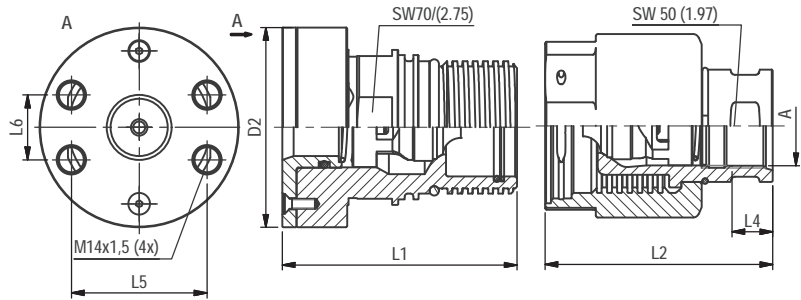

SW: Width across flats. All dimensions in mm (inch).

Series PS-25 • BG 08 • Nominal Size 25

Port A	Dimensions (^{mm} / _{in})							Female Body Ordering Codes	Weight (^{kg} / _{lbs}) ca. per 100	Male Tip Ordering Codes	Weight (^{kg} / _{lbs}) ca. per 100
	ØD2	L1	L2	L3	L4	L5	L6				
Flange SAE 6000 PSI											
	1"	98	115,5 4.55	115,5 4.55		66,7 2,62	31,8 1,24	QRC-PS-25-F-C620M-S3-W3	300,40 662,27		
Female Thread according to SAE J1926-14 - ISO 11926-1											
	UN 1" 5/8 -12		112 4.41	19 .75						QRC-PS-25-M-U20-HB-W3	262,60 578,93
	Female Thread according to DIN 3852-2-A										
	G 1" 1/4	76 2.99	122 4.80	112 4.41	21,5 .85			QRC-PS-25-F-G20-S3-W3	244 537.93	QRC-PS-25-M-G20-HB-W3	255,90 564.16

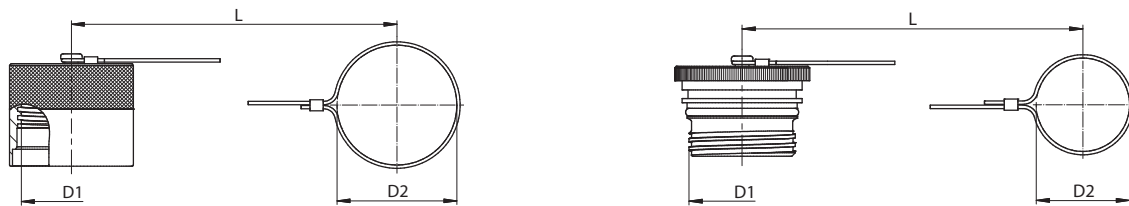
PS
Series PS • Dust Protection

Dimensions (^{mm} / _{in})			Material	Dust Cap for Female Body
D1	D2	L		Ordering Codes
So. 65x5	80 3.15	280 11.02	Aluminium silver with steel cable	QRC-PS-25-DF-80-W89-SI

Dimensions (^{mm} / _{in})			Material	Dust Plug for Male Tip
D1	D2	L		Ordering Codes
So. 65x5	56 2.20	240 9.45	Aluminium silver with steel cable	QRC-PS-25-DM-56-W89-SI

Note: The connection of the two halves of a coupling is achieved depending on the type. It is important to observe the positive engagement of plug-type couplings and the secure tightening of screw-type couplings to the limit stop of the thread. Forced or improper separation will result in malfunction of the coupling.



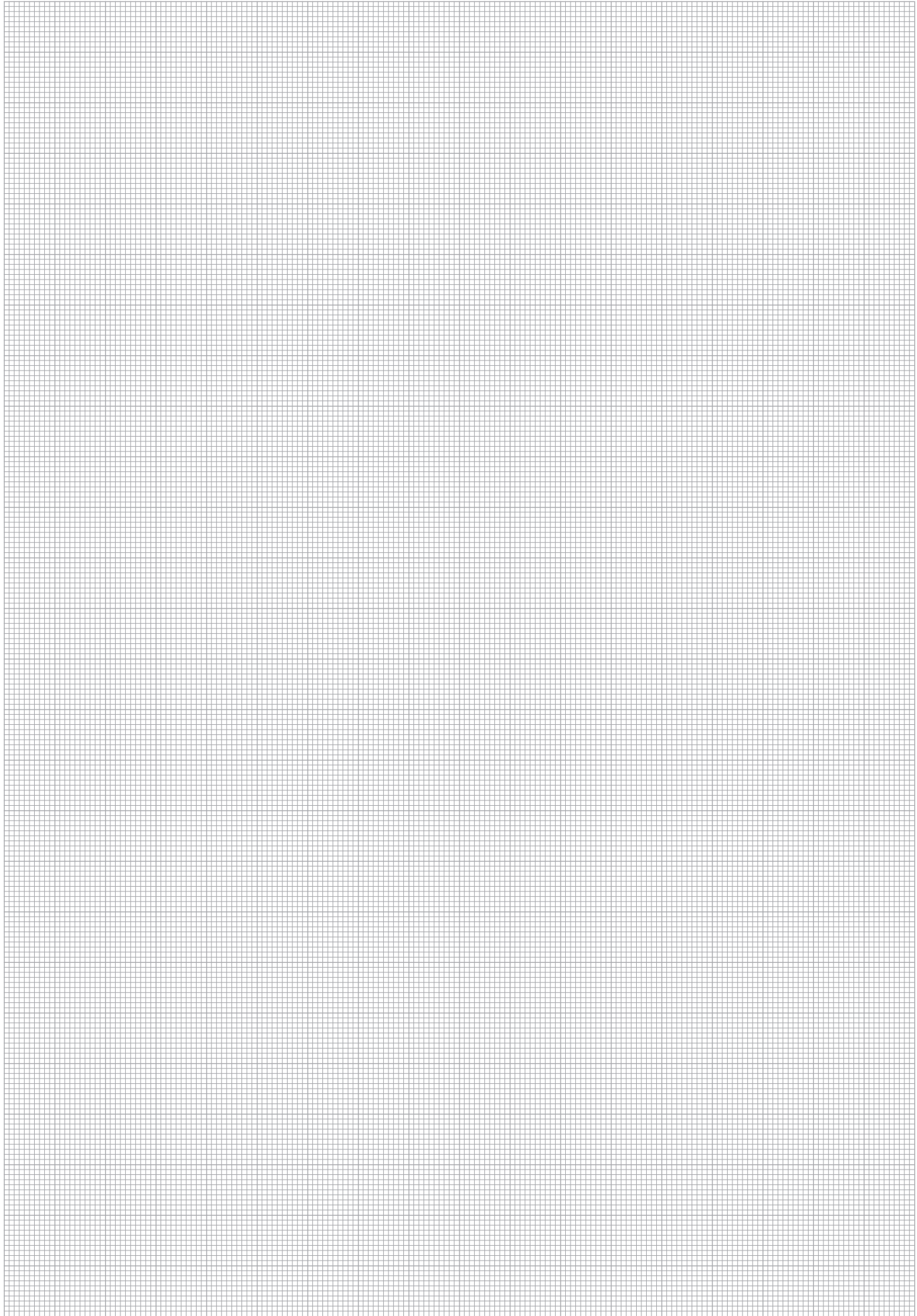

PS



Series RH • Carbon Steel
Product Description

Flat Face screw-to-connect couplings of the RH Series from STAUFF consist of a female body with external thread and a male tip with a screw sleeve. The Series is developed for extra heavy-duty applications for connecting of large diameter hydraulic lines up to DN 25 (1").

Coupling (screwing) and uncoupling (unscrewing) of the two halves is safe and very easy. After the connection is complete, all internal components have minimal play or clearance, which significantly reduces the risk of material fatigue.

Another advantage is that the risk of permanent indentation, so-called "brinelling", on the surface of the male tip is eliminated, which can occur with push-to-connect couplings in similar extreme applications.

The proven design is suitable for use in heavy duty construction and transportation modules, drilling rigs and trailer equipment. Other applications may, depending on the pressure and flow characteristics, include oil equipment steel mill machinery, and other demanding hydraulic applications.

The RH Series is available in nominal sizes: 10, 12,5, 16, 19, 25 (3/8" - 1").

Features

- Flat Face
- Coupling made from carbon steel with Zinc/Nickel surface coating
- Sealing's made from FKM (Viton®), HNBR, PTFE
- Heavy duty internal components
- Suitable for panel mounting

Applications

Self-Propelled
Modular Transporters

Top Features

Zinc/Nickel coating



Vibration resistant



Suitable for
panel mounting



Designed for secure
connection

RH

Series RH - Carbon Steel

Material	Carbon Steel
Surface Finishing	Zinc-Nickel
Standard Seal Material(s)	NBR (Buna-N®), PTFE ²
Working Temperature	-30° C ... +100° C / -22° F ... +212° F
Valve Design	Flat Valve
Connection	Screw
Disconnection	Screw
Connect Under Pressure	Max. 20 bar / 290 PSI Residual Pressure with Tools allowed
Application	Construction Machinery
ISO Interchange	-



² Alternative seal materials are available on request.

Technical Data

Series	BG	DN Zoll Inch	DN metric ISO 4397	Q _{max}		Working Pressure*		Bursting Pressure Connected		Female Body		Male Tip		Spillage	
				l/min	US GPM	bar	PSI	bar	PSI	bar	PSI	bar	PSI	ml	fl oz
RH-10	2	3/8"	10	46	21094	420	6092	1300	18855	1350	19580	1450	210301	0,1	.0034
RH-12	3	1/2"	12,5	106	18.49	420	6092	1260	18275	1260	18275	1260	18275	0,16	.0054
RH-16	4	5/8"	16	148	27.77	420	6092	1260	18275	1260	18275	1260	18275	1,02	.0344
RH-19	6	3/4"	19	200	52.83	420	6092	1400	20305	1400	20305	1200	17405	0,86	.0291
RH-25	8	1"	25	500	132.09	420	6092	1150	16679	1100	15954	900	13053	2,84	.0960

The indicated pressure ratings only apply to the coupling itself and depend on the connection type.
* in connected and disconnected condition.

Flow Characteristics

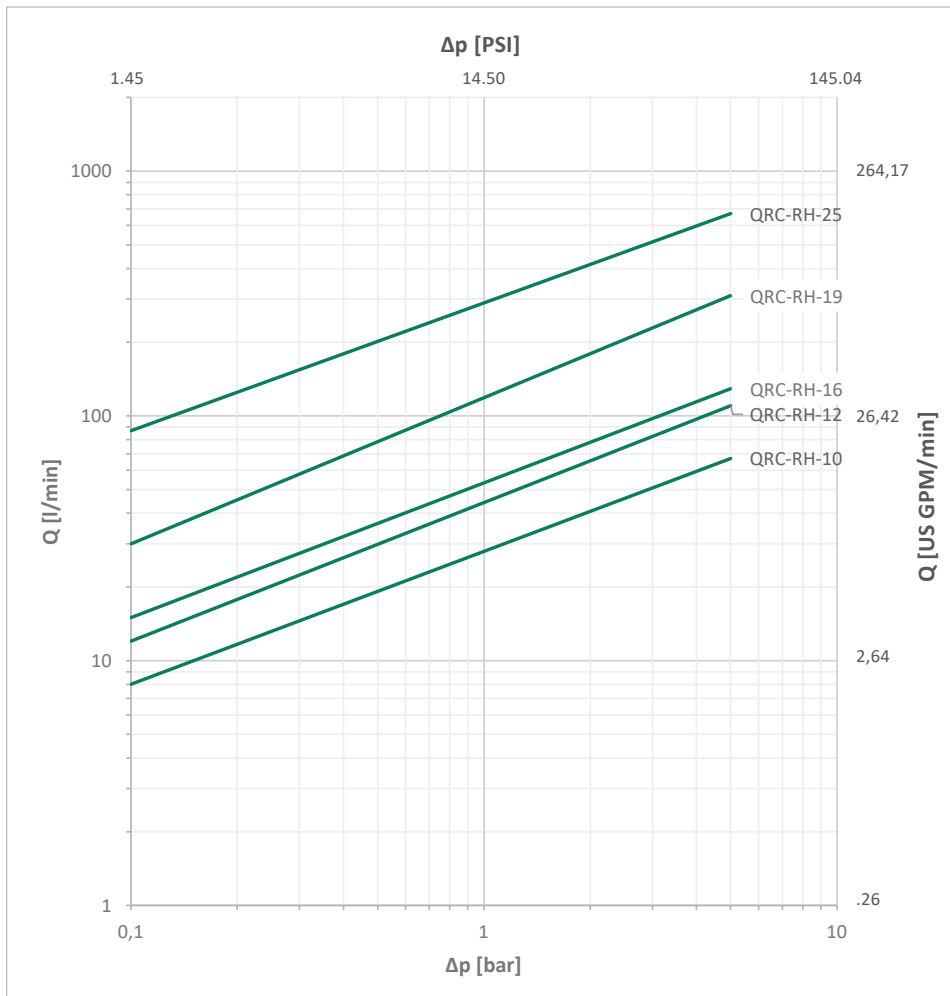

Please note: Unless otherwise stated, all flow characteristics have been determined with hydraulic oil with a kinematic viscosity of 28,8 - 35,2 mm²/s (28,8 - 35,2 cSt) and are only valid for components with non-reducing connections.

RH



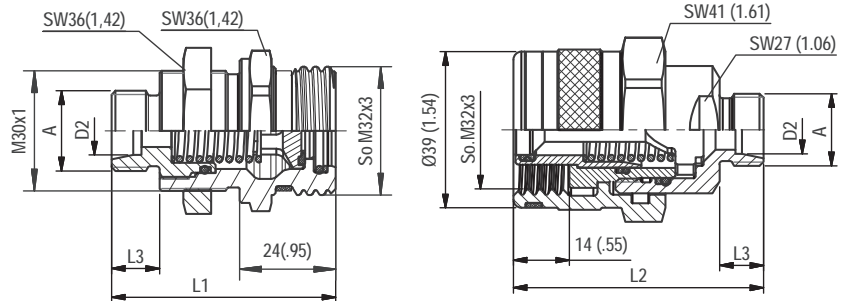

SW: Width across flats. All dimensions in mm (inch).

Series RH-10 • BG 2 • Nominal Size 10

Port A	Dimensions (^{mm} / _{in})					Female Body Ordering Codes	Weight (^{kg} / _{lbs}) ca. per 100	Male Tip Ordering Codes	Weight (^{kg} / _{lbs}) ca. per 100
	ØD2	L1	L2	L3	L4				
Male Thread with 24° Conical Bore - Shape W according to DIN 3861									
	M14x1.5	8L	54 2.13	61 2.40	10 .39	QRC-RH-10-F-08L-S1-W3	20,80 45.86	QRC-RH-10-M-08L-BT-W3	31,80 70.11
	M16x1.5	10L	55 2.17	61 2.40	11 .43	QRC-RH-10-F-10L-S1-W3	21 46.30	QRC-RH-10-M-10L-BT-W3	32 70.55
	M18x1.5	12L	55 2.17	61 2.40	11 .43	QRC-RH-10-F-12L-S1-W3	21,20 46.74	QRC-RH-10-M-12L-BT-W3	32,20 70.99
	M22x1.5	15L	56 2.20	62 2.44	12 .47	QRC-RH-10-F-15L-S1-W3	22 48.50	QRC-RH-10-M-15L-BT-W3	32,90 72.53
	M18x1.5	10S	56 2.20	62 2.44	12 .47	QRC-RH-10-F-10S-S1-W3	21,50 47.40	QRC-RH-10-M-10S-BT-W3	32,60 71.87
	M20x1.5	12S	56 2.20	62 2.44	12 .47	QRC-RH-10-F-12S-S1-W3	22 48.50	QRC-RH-10-M-12S-BT-W3	33 72.75
	M22x1.5	14S	58 2.28	64 2.52	14 .55	QRC-RH-10-F-14S-S1-W3	22,70 50.04	QRC-RH-10-M-14S-BT-W3	33,80 74.52
	M24x1.5	16S	58 2.28	64 2.52	14 .55	QRC-RH-10-F-16S-S1-W3	23 50.71	QRC-RH-10-M-16S-BT-W3	33,90 74.74

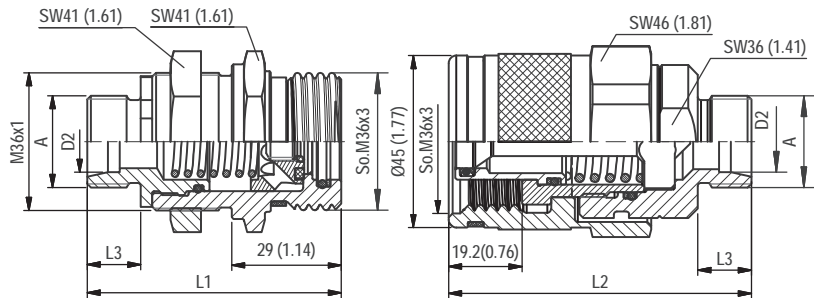

SW: Width across flats. All dimensions in mm (inch).

Series RH-12 • BG 3 • Nominal Size 12,5

Port A	Dimensions (^{mm} / _{in})					Female Body Ordering Codes	Weight (^{kg} / _{lbs}) ca. per 100	Male Tip Ordering Codes	Weight (^{kg} / _{lbs}) ca. per 100
	ØD2	L1	L2	L3	L4				
Male Thread with 24° Conical Bore - Shape W according to DIN 3861									
	M22x1.5	15L	65	78	12	QRC-RH-12-F-15L-S1-W3	31,20	QRC-RH-12-M-15L-BT-W3	56,40
			2.56	3.07	.47		68.78		124.34
	M24x1.5	16S	67	80	14	QRC-RH-12-F-16S-S1-W3	32	QRC-RH-12-M-16S-BT-W3	57,30
			2.64	3.15	.55		70.55		126.32
	M30x2	20S	69,5	81,2	16	QRC-RH-12-F-20S-S1-W3	34,80	QRC-RH-12-M-20S-BT-W3	59,50
			2.74	3.20	.63		76.72		131.18

Note: The connection of the two halves of a coupling is achieved depending on the type. It is important to observe the positive engagement of plug-type couplings and the secure tightening of screw-type couplings to the limit stop of the thread. Forced or improper separation will result in malfunction of the coupling.



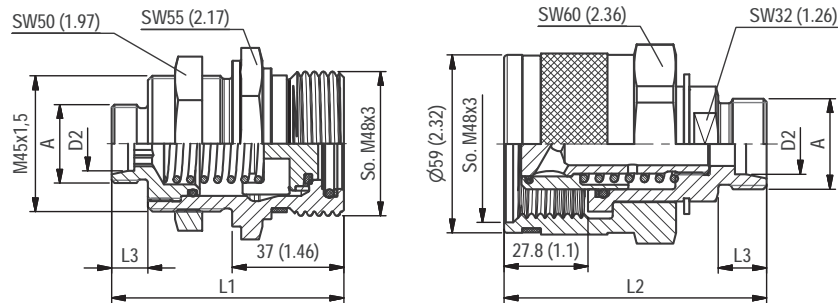

SW: Width across flats. All dimensions in mm (inch).

Series RH-16 • BG 4 • Nominal Size 16

Port A	Dimensions (mm/in)					Female Body Ordering Codes	Weight (kg/lbs) ca. per 100	Male Tip Ordering Codes	Weight (kg/lbs) ca. per 100
	ØD2	L1	L2	L3	L4				
Male Thread with 24° Conical Bore - Shape W according to DIN 3861									
	M22x1,5	15L	77 3.03	77 3.03	12 .47	QRC-RH-16-F-15L-S1-W3	61,40 135.36	QRC-RH-16-M-15L-BT-W3	94 207.23
	M26x1,5	18L	77 3.03	77 3.03	12 .47	QRC-RH-16-F-18L-S1-W3	61,60 135.80	QRC-RH-16-M-18L-BT-W3	94,30 207.90
			79 3.11	79 3.11	14 .55	QRC-RH-16-F-16S-S1-W3	61,70 136.03	QRC-RH-16-M-16S-BT-W3	94,50 208.34
	M30x2	20S	81 3.19	81 3.19	16 .63	QRC-RH-16-F-20S-S1-W3	62 136.69	QRC-RH-16-M-20S-BT-W3	94,90 209.22

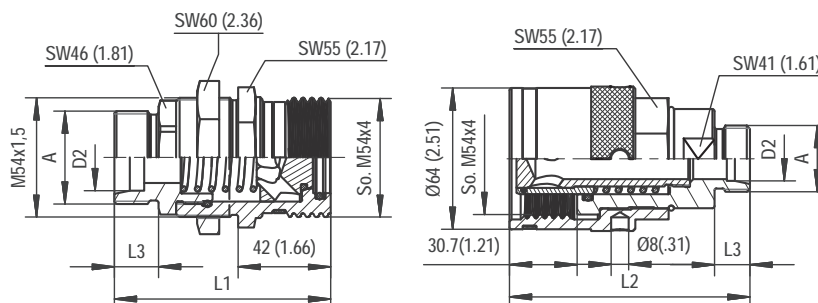

SW: Width across flats. All dimensions in mm (inch).

Series RH-19 • BG 6 • Nominal Size 19

Port A	Dimensions (mm/in)					Female Body Ordering Codes	Weight (kg/lbs) ca. per 100	Male Tip Ordering Codes	Weight (kg/lbs) ca. per 100
	ØD2	L1	L2	L3	L4				
Male Thread with 24° Conical Bore - Shape W according to DIN 3861									
	M26x1,5	18L	90 3.54	103 4.06	12 .47	QRC-RH-19-F-18L-S1-W3	88 194.01	QRC-RH-19-M-18L-BT-W3	128,80 283.96
			M30x2	22L	92 3.62	105 4.13	14 .55	QRC-RH-19-F-22L-S1-W3	88,80 195.77
	M36x2	28L			92 3.62	107 4.21	14 .55	QRC-RH-19-F-28L-S1-W3	90 198.42
			M30x2	20S	95 3.74	109 4.29	16 .63	QRC-RH-19-F-20S-S1-W3	92,20 203.27
	M36x2	25S			97 3.82	111 4.37	18 .71	QRC-RH-19-F-25S-S1-W3	93 205.03
			M42x2	30S	99 3.90	113 4.45	20 .79	QRC-RH-19-F-30S-S1-W3	95,80 211.20

Note: The connection of the two halves of a coupling is achieved depending on the type. It is important to observe the positive engagement of plug-type couplings and the secure tightening of screw-type couplings to the limit stop of the thread. Forced or improper separation will result in malfunction of the coupling.



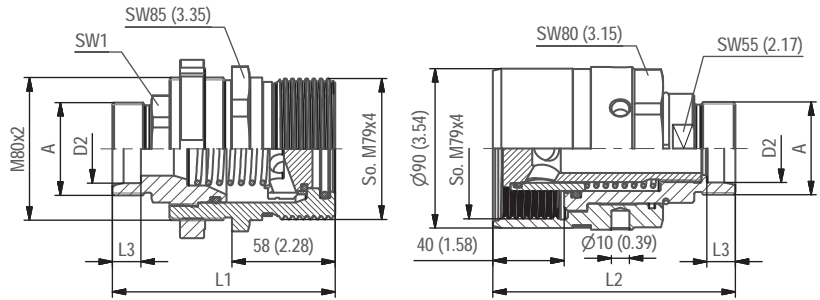

SW: Width across flats. All dimensions in mm (inch).

Series RH-25 • BG 8 • Nominal Size 25

Port A	Dimensions (mm/in)						Female Body	Weight (kg/lbs) ca. per 100	Male Tip	Weight (kg/lbs) ca. per 100
	ØD2	L1	L2	L3	L4	SW1				
Male Thread with 24° Conical Bore - Shape W according to DIN 3861										
	M45x2	35L	122 4.80	136 5.35	16 .63	46 1.81	QRC-RH-25-F-35L-S1-W3	273 601.86	QRC-RH-25-M-35L-BT-W3	335 738.55
	M52x2	42L	122 4.80	136 5.35	16 .63	55 2.17	QRC-RH-25-F-42L-S1-W3	283 623.91	QRC-RH-25-M-42L-BT-W3	335 738.55
	M52x2	38S	125 4.92	136 5.35	22 .87	55 2.17	QRC-RH-25-F-38S-S1-W3	285.50 629.42	QRC-RH-25-M-38S-BT-W3	334.50 737.45

Series RH • Dust Protection

Dimensions (mm/in)			Material	Dust Cap for Female Body
D1	D2	L		Ordering Codes
M32x3	36,5 1.44	190 7.48	Plastic (Colour: Red)	QRC-RH-10-DF-37-K-RD
M32x3	29,5 1.16	185 7.28		QRC-RH-10-DF-30-K-RD
M36x3	41 1.61	190 7.48	Plastic (Colour: Red)	QRC-RH-12-DF-41-K-RD
M48x3	55 2.17	210 8.27		QRC-RH-16-DF-55-K-RD

Dimensions (mm/in)			Material	Dust Plug for Male Tip
D1	D2	L		Ordering Codes
M32x3	29,5 1.16	185 7.28	Plastic (Colour: Red)	QRC-RH-10-DM-30-K-RD
M36x3	29,5 1.16	185 7.28		QRC-RH-12-DM-30-K-RD
M48x3	36,5 1.44	190 7.48	Plastic (Colour: Red)	QRC-RH-16-DM-37-K-RD

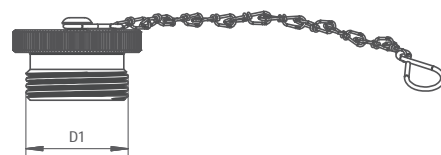
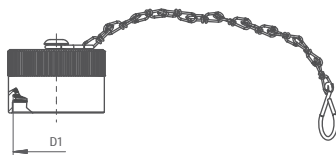

Dimensions (mm/in)			Material	Dust Cap for Female Body
D1	D2	L		Ordering Codes
So. M48x3			Aluminium silver with chain	QRC-RH-16-DF-CN-W89-SI
So. M54x4				QRC-RH-19-DF-CN-W89-SI
So. M79x4				QRC-RH-25-DF-CN-W89-SI

Dimensions (mm/in)			Material	Dust Plug for Male Tip
D1	D2	L		Ordering Codes
So. M48x3			Aluminium silver with chain	QRC-RH-16-DM-CN-W89-SI
So. M54x4				QRC-RH-19-DM-CN-W89-SI
So. M79x4				QRC-RH-25-DM-CN-W89-SI

In addition to the standard colours as stated above, plastic dust caps are also available in blue, green, yellow and black. Please use the color codes BU, GN, YE and BK respectively instead of RD.

Note: The connection of the two halves of a coupling is achieved depending on the type. It is important to observe the positive engagement of plug-type couplings and the secure tightening of screw-type couplings to the limit stop of the thread. Forced or improper separation will result in malfunction of the coupling.



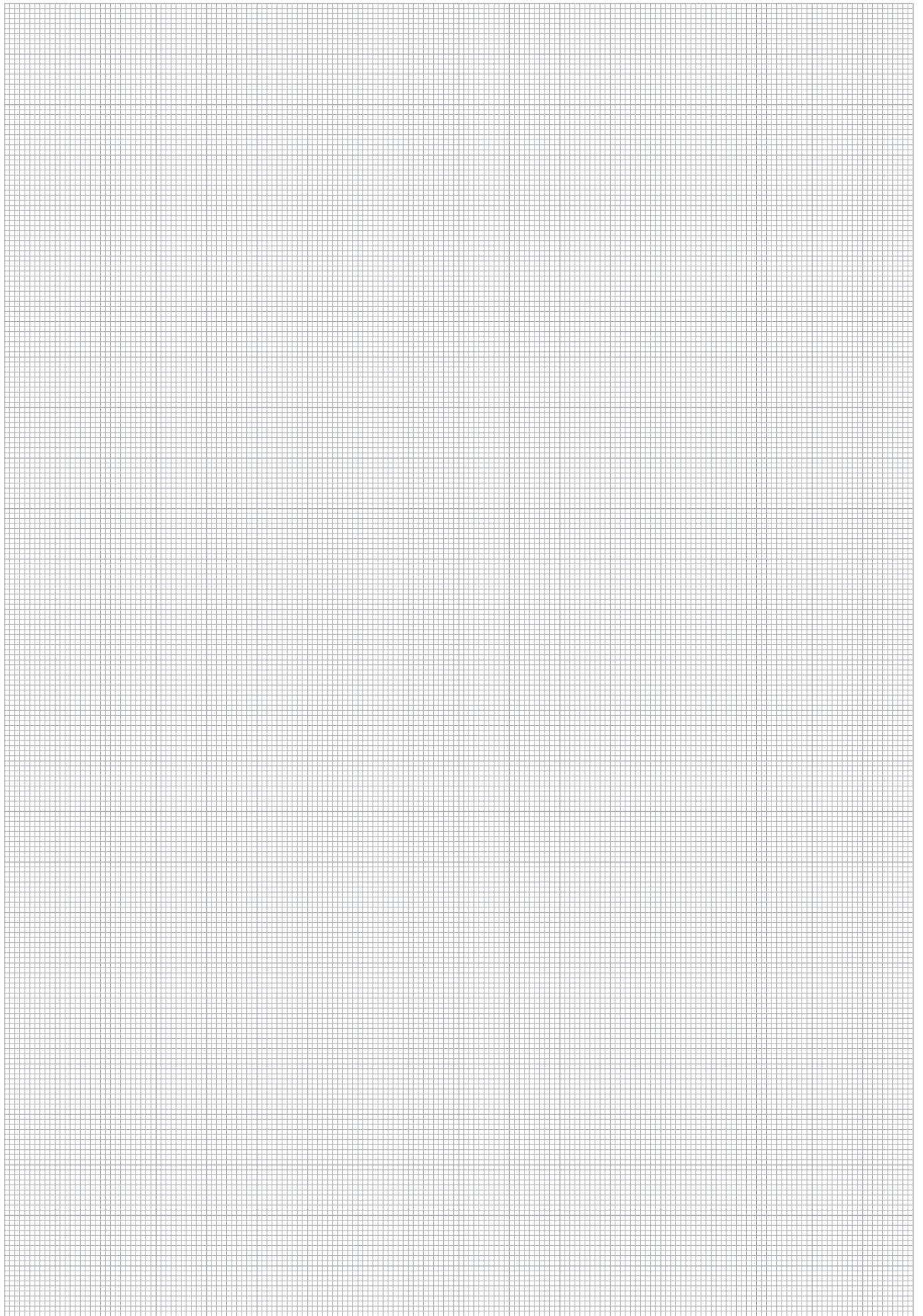

RH



Series FG • Carbon Steel
Product Description

Flat Face screw-to-connect couplings of the FG Series from STAUFF consist of a female body with a screw sleeve and a male tip with external thread. The Series is developed for particularly heavy-duty applications for connecting hydraulic lines up to DN31,5 (1 1/4").

Coupling (screwing) and uncoupling (unscrewing) of the two halves is safe and very easy. After the connection is complete, all internal components have minimal play or clearance, which significantly reduces the risk of material fatigue.

Another advantage is that the risk of permanent indentation, so-called "brinelling", on the surface of the male tip is eliminated, which can occur with push-to-connect couplings in similar extreme applications.

The proven design is suitable for use in heavy construction and transport equipment, oil and gas platforms, blow out preventer (BOP) systems and gensets. Other applications include heavy lifting equipment, loaders/trailers, Drilling rigs, Piling Rigs and other demanding hydraulic applications.

The FG Series is available in nominal sizes 10, 12, 16, 19, 25, 31,5 (3/8" - 1 1/4").

The nominal sizes 12, 16, 19 and 25 are certified according to API-16D (American Petroleum Institute) and EUB Directive 036 by LRQA (Lloyd's Register): Fire resistance test at 345 bar (5000 PSI) and a flametemperature of 700° C (1300° F).

Features

- Flat Face
- Coupling made from carbon steel with Zinc/Nickel surface coating
- Sealing's made from NBR (Buna-N®), PTFE, PU, POM
- Heavy duty internal components
- Male tip or female can be connected up to 250 bar (3626 PSI) by hand or easy with tool
- Tested acc. API-16D and acc. EUB Directive 036 (nominal sizes 12, 16, 19, 25)
- Feature: Green O-Ring
External O-ring as a safety feature to indicate the complete/correct connection of the male tip and female body (the O-ring must be covered by the sleeve of the female body)

Applications

	Construction Machinery		Hydraulic trailers		Lifting Equipment
	Oil and gas industry (onshore)		Hydraulic tippers		

Top Features

	Zinc/Nickel coating		Designed for secure connection		Connect Under pressure
	Vibration resistant				

FG

Series FG - Carbon Steel

Material	Carbon Steel
Surface Finishing	Zink/Nickel
Standard Seal Material(s)	NBR (Buna-N®), PTFE, PU, POM
Working Temperature	-25° C ... +100° C / -13° F ... +212° F
Valve Design	Flat Face
Connection	Screw
Disconnection	Screw
Connect Under Pressure	Male Tip or Female Body up to 250 bar (3626 PSI) allowed
Disconnect Under Pressure	allowed
Application	Construction Machinery, Industrial Hydraulic, Onshore
ISO Interchange	-



Technical Data

Series	BG	DN Zoll Inch	DN metric ISO 4397	Q _{max}		Working Pressure Connected		Female Body		Male Tip		Spillage	
				l/min	US GPM	bar	PSI	bar	PSI	bar	PSI	ml	fl oz
FG-10	2	3/8"	10	46	12.15	550	7977	330	4786	550	7977	0,01	.0003
FG-12	3	1/2"	12,5	90	23.77	550	7977	330	4786	550	7977	0,01	.0003
FG-16	4A	5/8"	16	148	39.09	550	7977	330	4786	550	7977	0,02	.0007
FG-19	4	3/4"	19	200	52.83	500	7252	330	4786	500	7252	0,01	.0003
FG-25	5	1"	25	378	99.86	470	6817	300	4351	470	6817	0,005	.00017
FT-31	6	1 1/4"	31,5	600	158.50	400	5802	400	5802	400	5802		

Series	Bursting Pressure Connected		Female Body		Male Tip		Maximum pressure for connecting						Maximum pressure for disconnecting	
	bar	PSI	bar	PSI	bar	PSI	Pressure on Male Tip		Pressure on Female Body		Pressure on Female Body for disconnecting		bar	PSI
							Female Body pressureless	Male Tip pressureless	Male Tip pressureless	Pressure on Male Tip				
FG-10	1400	20305	1000	14504	1400	20305	250	3626	250	3626	250	3626	250	3626
FG-12	1400	20305	1000	14504	1400	20305	250	3626	250	3626	200	2901	200	2901
FG-16	1400	20305	1000	14504	1400	20305	250	3626	250	3626	200	2901	200	2901
FG-19	1400	20305	1000	14504	1400	20305	250	3626	250	3626	150	2176	150	2176
FG-25	1200	17405	800	11603	1200	17405	250	3626	250	3626	150	2176	150	2176
FT-31	1100	15954	1100	15954	1100	15954	250	3626	150	2176	50	725		

The indicated pressure ratings only apply to the coupling itself and depend on the connection type.

Flow Characteristics

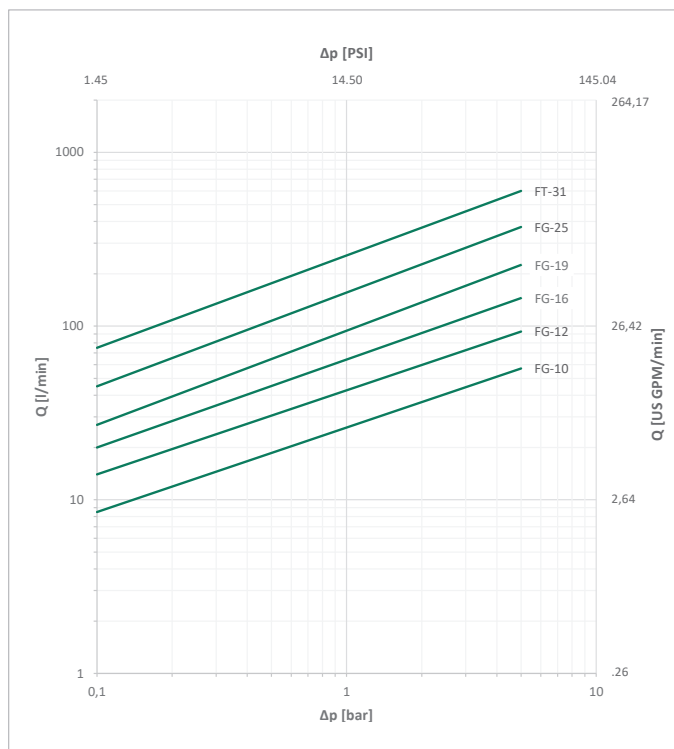

Please note: Unless otherwise stated, all flow characteristics have been determined with hydraulic oil with a kinematic viscosity of 28,8 - 35,2 mm²/s (28,8 - 35,2 cSt) and are only valid for components with non-reducing connections.

FG



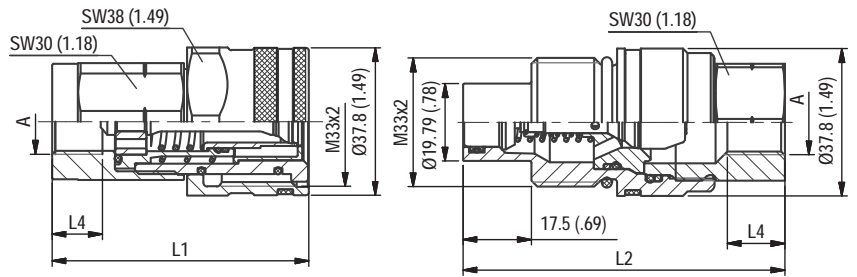

Insertion Male Tip = 16.9 (.67)
All dimensions in mm (inch).

Series FG-10 • BG 2 • Nominal Size 10

Port A	Dimensions (mm/in)					Female Body Ordering Codes	Weight (^{kg} /lbs) ca. per 100	Male Tip Ordering Codes	Weight (^{kg} /lbs) ca. per 100
	ØD2	L1	L2	L3	L4				
Female Thread according to DIN 3852-2 - ANSI B 1.20.3 - SAE J1926-1 - ISO 11926-1									
	G 3/8"	65,8	82,3		12,9	QRC-FG-10-F-G06-S1-W3	34,70	QRC-FG-10-M-G06-S5-W3	38,40
		2.59	3.25		.51		76.50		84.66
	G 1/2"	70,4	82,3		14	QRC-FG-10-F-G08-S1-W3	35,20	QRC-FG-10-M-G08-S5-W3	36,80
		2.77	3.25		.55		77.60		81.13
	NPTF 3/8" -18	65,8	82,3			QRC-FG-10-F-NF06-S1-W3	34,50	QRC-FG-10-M-NF06-S5-W3	38,20
		2.59	3.25				76.06		84.22
	NPTF 1/2" -14	71,4	82,3			QRC-FG-10-F-NF08-S1-W3	36,00	QRC-FG-10-M-NF08-S5-W3	36,90
		2.81	3.25				79.37		81.35
	UNF 3/4" -16	70,4	82,3		16	QRC-FG-10-F-U08-S1-W3	35,60	QRC-FG-10-M-U08-S5-W3	37,20
		2.77	3.25		.63		78.48		82.01

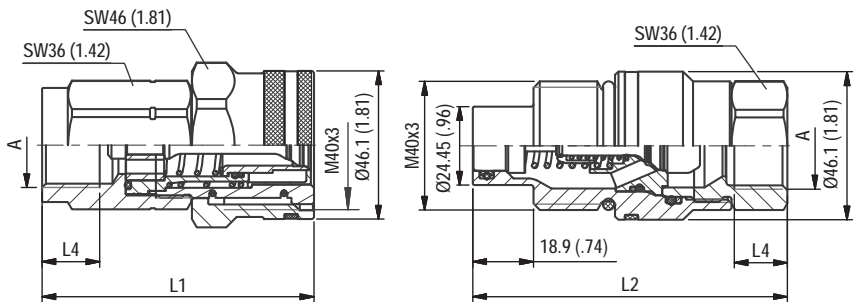

Insertion Male Tip = 18.4 (.72)
All dimensions in mm (inch).

Series FG-12 • BG 3 • Nominal Size 12,5

Port A	Dimensions (mm/in)					Female Body Ordering Codes	Weight (^{kg} /lbs) ca. per 100	Male Tip Ordering Codes	Weight (^{kg} /lbs) ca. per 100
	ØD2	L1	L2	L3	L4				
Female Thread according to DIN 3852-2 - ANSI B 1.20.3 - SAE J1926-1 - ISO 11926-1									
	G 1/2"	84,7	96		14	QRC-FG-12-F-G08-S1-W3	67,10	QRC-FG-12-M-G08-S5-W3	67,10
		3.34	3.78		.55		147.93		147.93
	G 3/4"	84,7	97		18	QRC-FG-12-F-G12-S1-W3	63,70	QRC-FG-12-M-G12-S5-W3	64,80
		3.34	3.82		.71		140.43		142.86
	NPTF 1/2" -14	83,7	96			QRC-FG-12-F-NF08-S1-W3	66,80	QRC-FG-12-M-NF08-S5-W3	67,60
		3.30	3.78				147.27		149.03
	NPTF 3/4" -14	84,7	96			QRC-FG-12-F-NF12-S1-W3	64,90	QRC-FG-12-M-NF12-S5-W3	65,00
		3.34	3.78				143.08		143.30
	UNF 3/4" -16	84,7	96		16	QRC-FG-12-F-U08-S1-W3	67,60	QRC-FG-12-M-U08-S5-W3	67,70
		3.35	3.78		.63		149.03		149.25
UN 1" 1/16 -12	84,7	98		19	QRC-FG-12-F-U12-S1-W3	63,00	QRC-FG-12-M-U12-S5-W3	64,60	
	3.35	3.86		.75		138.89		142.42	

FG

Note: The connection of the two halves of a coupling is achieved depending on the type. It is important to observe the positive engagement of plug-type couplings and the secure tightening of screw-type couplings to the limit stop of the thread. Forced or improper separation will result in malfunction of the coupling.



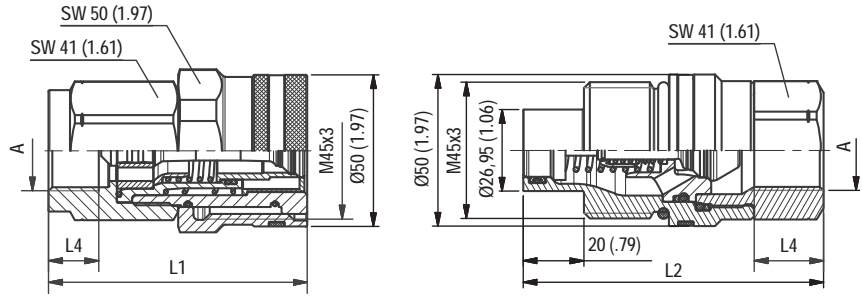

Insertion Male Tip = 19,0 (.75)
All dimensions in mm (inch).

Series FG-16 • BG 4A • Nominal Size 16

Port A	Dimensions (mm/in)					Female Body Ordering Codes	Weight (kg/lbs) ca. per 100	Male Tip Ordering Codes	Weight (kg/lbs) ca. per 100
	ØD2	L1	L2	L3	L4				
Female Thread according to DIN 3852-2 - ANSI B 1.20.3 - SAE J1926-1 - ISO 11926-1									
	G 3/4"	85	99		16,5	QRC-FG-16-F-G12-S1-W3	93	QRC-FG-16-M-G12-S5-W3	76,9
		3.35	3.90		.65		205.05		169.54
	G 1"	89	105		19	QRC-FG-16-F-G16-S1-W3	88,5	QRC-FG-16-M-G16-S5-W3	75,6
		3.50	4.13		.75		195.10		166.67
NPTF 3/4" -14	85	102			QRC-FG-16-F-NF12-S1-W3	91,7	QRC-FG-16-M-NF12-S5-W3	79,2	
	3.35	4.02				202.16		174.60	
UN 1" 1/16 -12	88	102		19	QRC-FG-16-F-U12-S1-W3	93,5	QRC-FG-16-M-U12-S5-W3	78,5	
	3.46	4.02		.75		206.13		173.06	

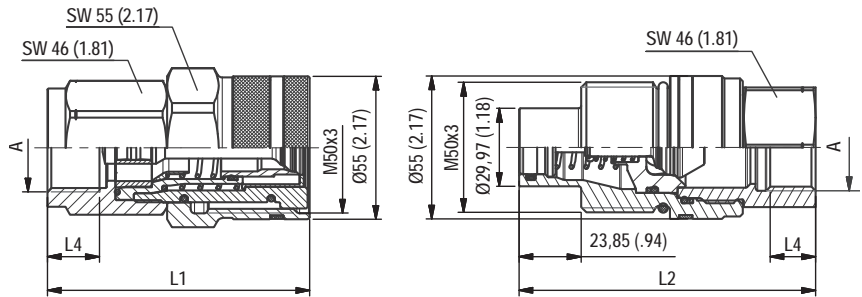

Insertion Male Tip = 22,7 (.89)
All dimensions in mm (inch).

Series FG-19 • BG 4 • Nominal Size 19

Port A	Dimensions (mm/in)					Female Body Ordering Codes	Weight (kg/lbs) ca. per 100	Male Tip Ordering Codes	Weight (kg/lbs) ca. per 100
	ØD2	L1	L2	L3	L4				
Female Thread according to DIN 3852-2 - ANSI B 1.20.3 - SAE J1926-1 - ISO 11926-1									
	G 3/4"	101	114		16	QRC-FG-19-F-G12-S1-W3	120,60	QRC-FG-19-M-G12-S5-W3	115,90
		3.98	4.49		.63		265.88		255.52
	G 1"	101	114		20	QRC-FG-19-F-G16-S1-W3	115,20	QRC-FG-19-M-G16-S5-W3	107,60
		3.98	4.49		.79		253.97		237.22
NPTF 1" -11 1/2	101	114			QRC-FG-19-F-NF16-S1-W3	116,60	QRC-FG-19-M-NF16-S5-W3	109,40	
	3.98	4.49				257.06		241.16	
UN 1" 5/16 -12	101	114		20	QRC-FG-19-F-U16-S1-W3	114,70	QRC-FG-19-M-U16-S5-W3	109,50	
	3.98	4.49		.79		252.87		241.40	

Note: The connection of the two halves of a coupling is achieved depending on the type. It is important to observe the positive engagement of plug-type couplings and the secure tightening of screw-type couplings to the limit stop of the thread. Forced or improper separation will result in malfunction of the coupling.



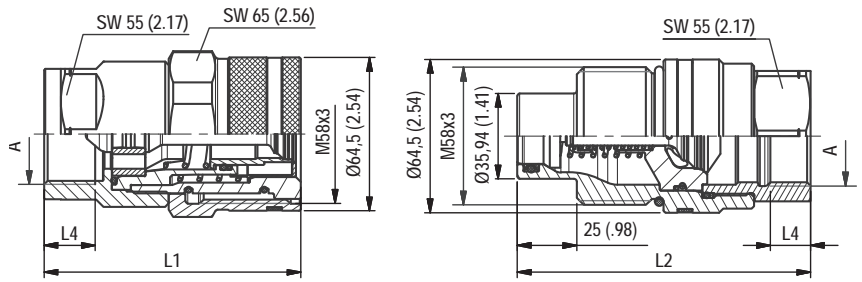

Insertion Male Tip = 24,1 (.95)
All dimensions in mm (inch).

Series FG-25 ▪ BG 5 ▪ Nominal Size 25

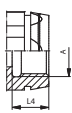
Port A	Dimensions (mm/in)				Female Body Ordering Codes	Weight (kg/lbs) ca. per 100	Male Tip Ordering Codes	Weight (kg/lbs) ca. per 100	
	ØD2	L1	L2	L3					L4
Female Thread according to DIN 3852-2 - ANSI B 1.20.3 - SAE J1926-1 - ISO 11926-1									
 G 1" 1/4		108	123,5		21,5	QRC-FG-25-F-G20-S1-W3	155,00	QRC-FG-25-M-G20-S5-W3	151,00
		4.25	4.86		.85			341.71	
 NPTF 1" 1/4 - 11 1/2		108	126,4			QRC-FG-25-F-NF20-S1-W3	155,00	QRC-FG-25-M-NF20-S5-W3	154,00
		4.25	4.98				341.71		339.51
 UN 1" 5/8 - 12		108	126,4		20	QRC-FG-25-F-U20-S1-W3	155,00	QRC-FG-25-M-U20-S5-W3	154,00
		4.25	4.98		.79		341.71		339.51

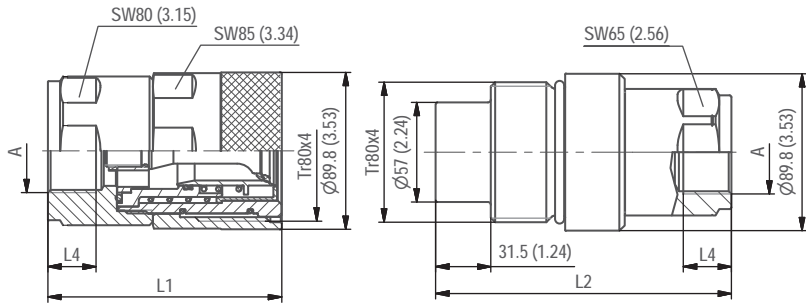

SW: Width across flats. All dimensions in mm (inch).

Series FT-31 ▪ BG 6 ▪ Nominal Size 31,5

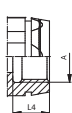
Port A	Dimensions (mm/in)				Female Body Ordering Codes	Weight (kg/lbs) ca. per 100	Male Tip Ordering Codes	Weight (kg/lbs) ca. per 100	
	ØD2	L1	L2	L3					L4
Female Thread according to DIN 3852-2 - ANSI B 1.20.3 - SAE J1926-1 - ISO 11926-1									
 G 1" 1/2		134	169		22	QRC-FT-31-F-G24-S1-W3	442,20	QRC-FT-31-M-G24-S2-W3	402
		5.28	6.65		.87			974.88	
 NPTF 1" 1/2 - 11		134	169			QRC-FT-31-F-NF24-S1-W3	444,20	QRC-FT-31-M-NF24-S2-W3	404,10
		5.28	6.65				979.29		890.89
 UN 1" 7/8 - 12		134	169		19	QRC-FT-31-F-U24-S1-W3	439,20	QRC-FT-31-M-U24-S2-W3	400,50
		5.28	6.65		.75		968.27		882.95

FG

Note: The connection of the two halves of a coupling is achieved depending on the type. It is important to observe the positive engagement of plug-type couplings and the secure tightening of screw-type couplings to the limit stop of the thread. Forced or improper separation will result in malfunction of the coupling.



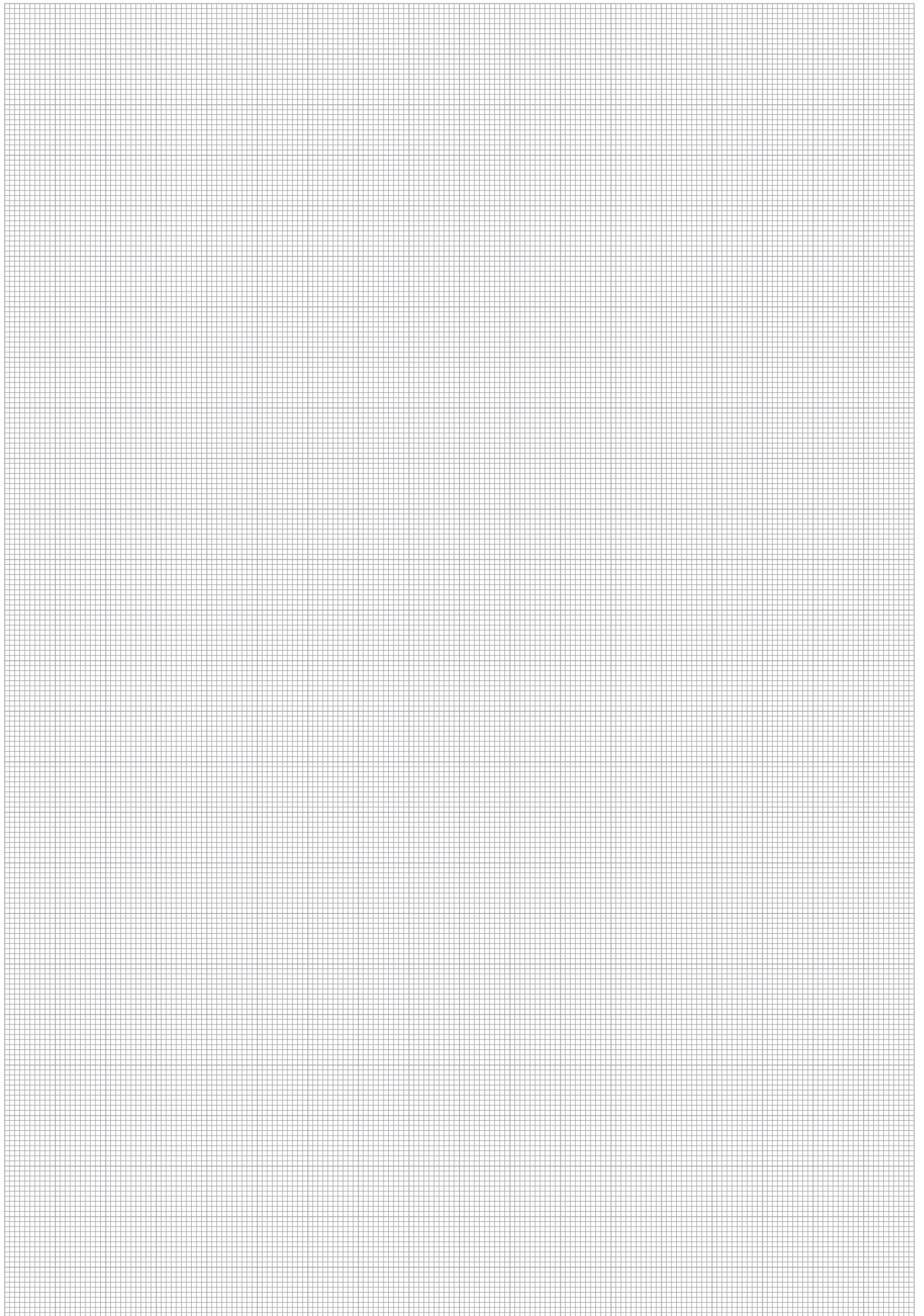

FG



Series HR • Carbon Steel
Product Description

Screw-to-connect couplings of the HR Series from STAUFF consist of a female body with external thread and a male tip with a screw sleeve. The Series is developed for particularly heavy-duty, high pressure and high pulsing applications for connecting hydraulic lines up to DN38 (1 1/2").

Coupling (screwing) and uncoupling (unscrewing) of the two halves is safe and very easy. After the connection is complete, all internal components have minimal play or clearance, which significantly reduces the risk of material fatigue.

Another advantage is that the risk of permanent indentation, so-called "brinelling", on the surface of the male tip is eliminated, which can occur with push-to-connect couplings in similar extreme applications.

The proven design is suitable for use in heavy construction machinery and available in nominal sizes 10, 12,5, 19, 25, 38 (3/8" - 1 1/2").

Features

- Poppet Valve
- Zinc-Plating and Thick-Film-Passivation (Chrome III)
- Can be connect under pressure up to 100 bar (1450 PSI)

Applications

Construction Machinery

Top Features

Vibration resistant



Connect Under pressure



Designed for secure connection

HR

Series HR ▪ Carbon Steel

Material	Carbon Steel
Surface Finishing	Zinc-Plating and Thick-Film-Passivation (Chrome III)
Standard Seal Material(s)	NBR (Buna-N®) ²
Working Temperature	-25° C ... +100° C / -13° F ... +212° F
Valve Design	Poppet Valve
Connection	Screw
Disconnection	Screw
Connect Under Pressure	Male Tip and Female Body up to max. 100 bar / 1450 PSI allowed
Application	Construction Machinery
ISO Interchange	-



² Alternative seal materials are available on request.

Technical Data

Series	BG	DN Zoll Inch	DN metric ISO 4397	Q _{max}		Working Pressure		Bursting Pressure Connected		Female Body		Male Tip		Spillage	
				l/min	US GPM	bar	PSI	bar	PSI	bar	PSI	bar	PSI	ml	fl oz
HR-10	2	3/8"	10	50	13.21	610	8847	2450	35534	2450	35534	2600	37710	2	.0676
HR-12	3	1/2"	12,5	85	22.45	470	6817	1900	27557	2100	30458	1650	23931	3	.1014
HR-19	4	3/4"	19 (20)	120	31.70	400	5802	1250	18130	1500	21756	1250	18130	10	.3381
HR-25	6	1"	25	280	73.97	400	5802	1300	18855	1600	23206	1100	15954	16	.5410
HR-31	8	1 1/4"	31	460	121.52	320	4641	1300	18855	1300	18855	1200	17405	30	10.144
HR-38	10	1 1/2"	38	700	184.92	300	4351	1100	15954	1500	21756	950	13779	54	18.260

The indicated pressure ratings only apply to the coupling itself and depend on the connection type.

Flow Characteristics

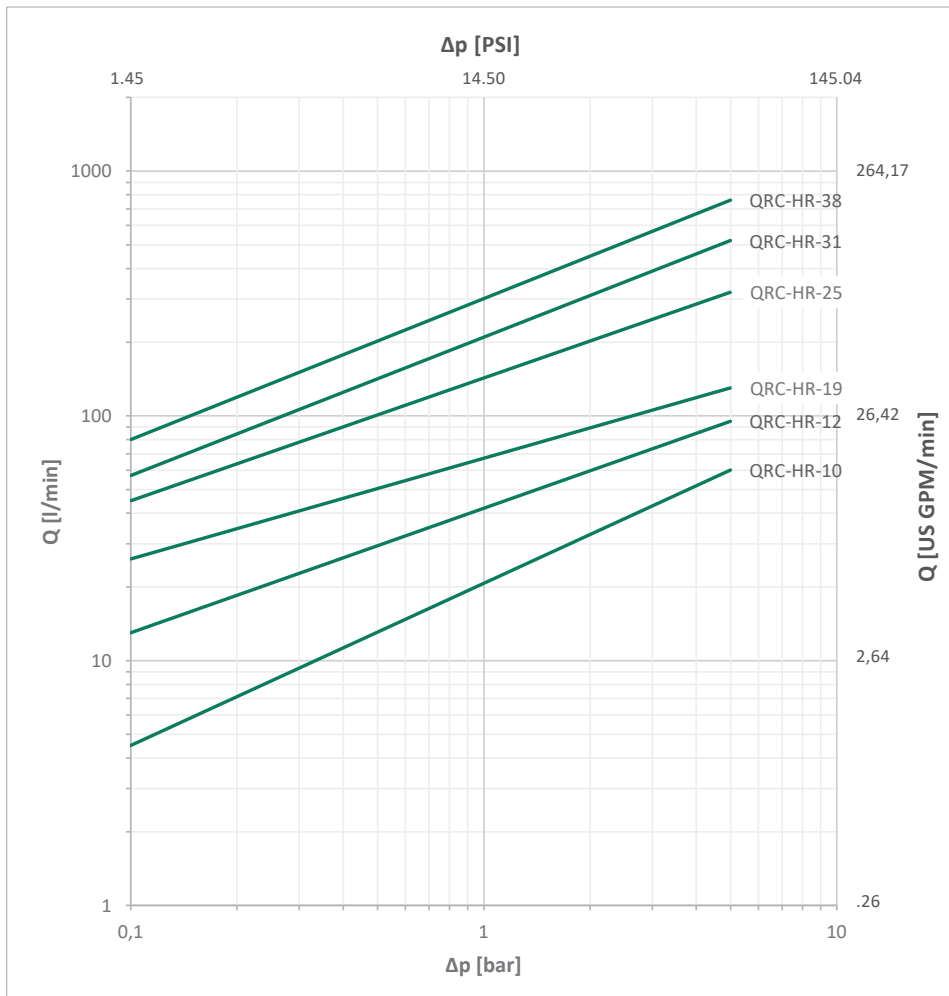

Please note: Unless otherwise stated, all flow characteristics have been determined with hydraulic oil with a kinematic viscosity of 28,8 - 35,2 mm²/s (28,8 - 35,2 cSt) and are only valid for components with non-reducing connections.



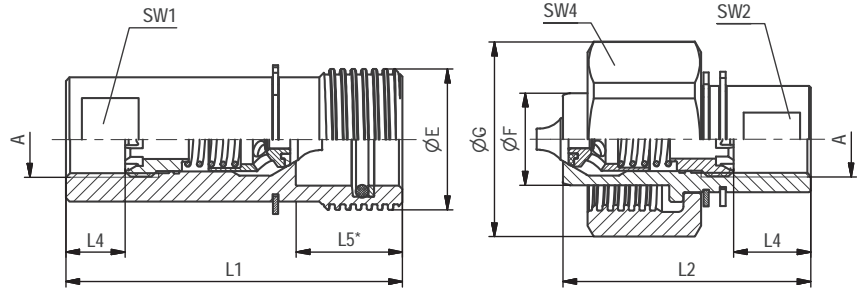

SW: Width across flats. All dimensions in mm (inch). Drawing similar Series HR-12.
* Insertion Female Body.

Series HR-10 • BG 2 • Nominal Size 10

Port A	Dimensions (^{mm} / _{in})										Female Body Ordering Codes	Weight (^{kg} / _{lbs}) ca. per 100	Male Tip Ordering Codes	Weight (^{kg} / _{lbs}) ca. per 100
	ØE	ØF	ØG	L1	L2	L4 min	L5	SW1	SW2	SW4				
Female Thread according to DIN 3852 - ISO 1179-1														
 G 3/8"	36	22	49	77	57	12	22	22	22	45	QRC-HR-10-F-G06-BT-W66	31,80	QRC-HR-10-M-G06-B-W66	35,20
	1.42	.87	1.93	3.03	2.24	.47	.87	.87	.87	1.77		70.11		77.60
	36	22	49	77	57	12	22	22	22	45	QRC-HR-10-FD-G06-BT-W66-DM	37,10	QRC-HR-10-MD-G06-B-W66-DM	41
	1.42	.87	1.93	3.03	2.24	.47	.87	.87	.87	1.77		81.79		90.39

Series HR-12 • BG 3 • Nominal Size 12,5

Port A	Dimensions (^{mm} / _{in})										Female Body Ordering Codes	Weight (^{kg} / _{lbs}) ca. per 100	Male Tip Ordering Codes	Weight (^{kg} / _{lbs}) ca. per 100
	ØE	ØF	ØG	L1	L2	L4 min	L5	SW1	SW2	SW4				
Female Thread according to DIN 3852 - ISO 1179-1														
 G 1/2"	40	26	55	95	70	14	30	26	26	50	QRC-HR-12-F-G08-BT-W66	48,40	QRC-HR-12-M-G08-B-W66	48
	1.57	1.02	2.16	3.74	2.76	.55	1.18	1.02	1.02	1.97		106.70		105.82
	40	26	55	95	70	14	30	26	26	50	QRC-HR-12-FD-G08-BT-W66-DM	54	QRC-HR-12-MD-G08-B-W66-DM	56,60
	1.57	1.02	2.16	3.74	2.76	.55	1.18	1.02	1.02	1.97		119.05		124.78

Series HR-19 • BG 4 • Nominal Size 19

Port A	Dimensions (^{mm} / _{in})										Female Body Ordering Codes	Weight (^{kg} / _{lbs}) ca. per 100	Male Tip Ordering Codes	Weight (^{kg} / _{lbs}) ca. per 100
	ØE	ØF	ØG	L1	L2	L4 min	L5	SW1	SW2	SW4				
Female Thread according to DIN 3852 - ISO 1179-1														
 G 3/4"	44,7	26	60	99	73	16	30	30	30	60	QRC-HR-19-F-G12-BT-W66	66	QRC-HR-19-M-G12-B-W66	59,90
	1.76	1.02	2.36	3.90	2.87	.63	1.18	1.18	1.18	2.36		145.51		132.06
	44,7	26	60	99	73	16	30	30	30	60	QRC-HR-19-FD-G12-BT-W66-DM	72,80	QRC-HR-19-MD-G12-B-W66-DM	68
	1.76	1.02	2.36	3.90	2.87	.63	1.18	1.18	1.18	2.36		160.50		149.91

Series HR-25 • BG 6 • Nominal Size 25

Port A	Dimensions (^{mm} / _{in})										Female Body Ordering Codes	Weight (^{kg} / _{lbs}) ca. per 100	Male Tip Ordering Codes	Weight (^{kg} / _{lbs}) ca. per 100
	ØE	ØF	ØG	L1	L2	L4 min	L5	SW1	SW2	SW4				
Female Thread according to DIN 3852 - ISO 1179-1														
 G 1"	58	36,8	77	106	81	18	30	40	40	77	QRC-HR-25-F-G16-BT-W66	117,90	QRC-HR-25-M-G16-B-W66	114,7
	2.28	1.45	3.02	4.17	3.19	.71	1.18	1.57	1.57	3.02		259.93		252.87
	58	36,8	77	106	81	18	30	40	40	77	QRC-HR-25-FD-G16-BT-W66-DM	125,70	QRC-HR-25-MD-G16-B-W66-DM	125,80
	2.28	1.45	3.02	4.17	3.19	.71	1.18	1.57	1.57	3.02		277.12		277.34

Note: The connection of the two halves of a coupling is achieved depending on the type. It is important to observe the positive engagement of plug-type couplings and the secure tightening of screw-type couplings to the limit stop of the thread. Forced or improper separation will result in malfunction of the coupling.



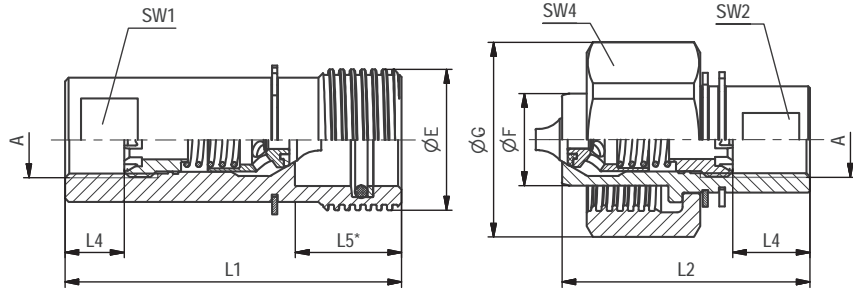

SW: Width across flats. All dimensions in mm (inch). Drawing similar Series HR-12.
* Insertion Female Body.

Series HR-31 • BG 8 • Nominal Size 31,5

Port A	Dimensions (mm/in)											Female Body Ordering Codes	Weight (kg/lbs) ca. per 100	Male Tip Ordering Codes	Weight (kg/lbs) ca. per 100	
	ØE	ØF	ØG	L1	L2	L4 min	L5	SW1	SW2	SW4						
Female Thread according to DIN 3852 - ISO 1179-1																
	G 1 1/4"	66	47	88	118	88	20	35	48	48	88	QRC-HR-31-F-G20-BT-W66	160,60	QRC-HR-31-M-G20-B-W66	180,30	
		2.60	1.85	3.46	4.65	3.46	.79	1.38	1.89	1.89	3.46		354.06		397.49	
		66	47	88	118	88	20	35	48	48	88	QRC-HR-31-FD-G20-BT-W66-DM	171,10	QRC-HR-31-MD-G20-B-W66-DM	192,80	
		2.60	1.85	3.46	4.65	3.46	.79	1.38	1.89	1.89	3.46		377.21		425.05	

Series HR-38 • BG 10 • Nominal Size 38

Port A	Dimensions (mm/in)											Female Body Ordering Codes	Weight (kg/lbs) ca. per 100	Male Tip Ordering Codes	Weight (kg/lbs) ca. per 100	
	ØE	ØF	ØG	L1	L2	L4 min	L5	SW1	SW2	SW4						
Female Thread according to DIN 3852 - ISO 1179-1																
	G 1 1/2"	75	57	93	121	90	22	35	55	55	93	QRC-HR-38-F-G24-BT-W66	200,60	QRC-HR-38-M-G24-B-W66	218,40	
		2.95	2.24	3.66	4.76	3.54	.87	1.38	2.16	2.16	3.66		442.25		481.49	
		75	57	93	121	90	22	35	55	55	93	QRC-HR-38-FD-G24-BT-W66-DM	213,90	QRC-HR-38-MD-G24-B-W66-DM	233,10	
		2.95	2.24	3.66	4.76	3.54	.87	1.38	2.16	2.16	3.66		471.57		513.90	

HR

Note: The connection of the two halves of a coupling is achieved depending on the type. It is important to observe the positive engagement of plug-type couplings and the secure tightening of screw-type couplings to the limit stop of the thread. Forced or improper separation will result in malfunction of the coupling.

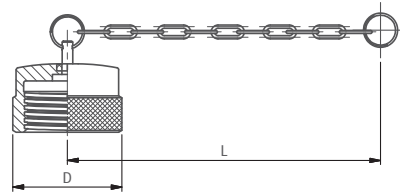
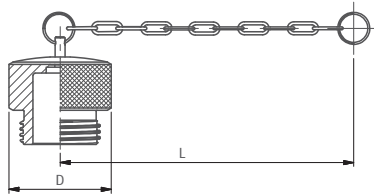

Series HR • Dust Protection

Dimensions (mm/in)			Material	Dust Plug for Male Tip
D1	D2	L		Ordering Codes
48		200	Plastic (Colour: Black)	QRC-HR-10-DM-CN-KI-BK
1.89		7.87		
51		200	Plastic (Colour: Black)	QRC-HR-12-DM-CN-KI-BK
2.01		7.87		
57		200	Plastic (Colour: Black)	QRC-HR-19-DM-CN-KI-BK
2.24		7.87		
68		200	Plastic (Colour: Black)	QRC-HR-25-DM-CN-KI-BK
2.68		7.87		
76		265	Plastic (Colour: Black)	QRC-HR-31-DM-CN-KI-BK
2.99		10.43		
86		265	Plastic (Colour: Black)	QRC-HR-38-DM-CN-KI-BK
3.39		10.43		

Dimensions (mm/in)			Material	Dust Cap for Female Body
D1	D2	L		Ordering Codes
48		200	Plastic (Colour: Black)	QRC-HR-10-DF-CN-KI-BK
1.89		7.87		
51		200	Plastic (Colour: Black)	QRC-HR-12-DF-CN-KI-BK
2.01		7.87		
57		200	Plastic (Colour: Black)	QRC-HR-19-DF-CN-KI-BK
2.24		7.87		
68		200	Plastic (Colour: Black)	QRC-HR-25-DF-CN-KI-BK
2.68		7.87		
76		265	Plastic (Colour: Black)	QRC-HR-31-DF-CN-KI-BK
2.99		10.43		
85		265	Plastic (Colour: Black)	QRC-HR-38-DF-CN-KI-BK
3.35		10.43		

In addition to the standard colours as stated above, plastic dust caps are also available in blue, green, yellow and black. Please use the color codes BU, GN, YE and BK respectively instead of RD.

Note: The connection of the two halves of a coupling is achieved depending on the type. It is important to observe the positive engagement of plug-type couplings and the secure tightening of screw-type couplings to the limit stop of the thread. Forced or improper separation will result in malfunction of the coupling.



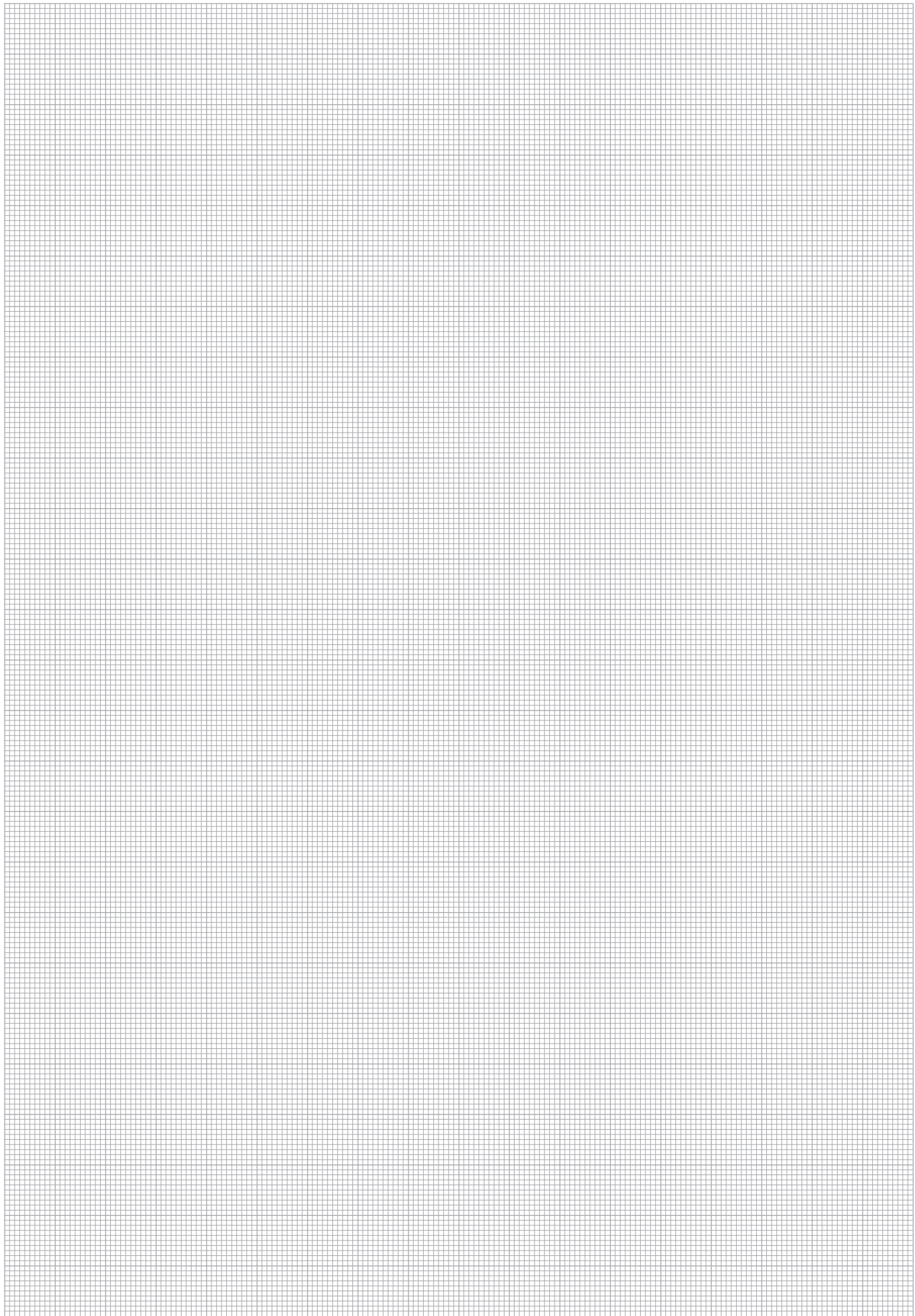

HR



Series HH • Carbon Steel
Product Description

Screw-to-connect couplings of the HH Series from STAUFF consist of a female body with a screw sleeve and a male tip with external thread. The Series is developed for high working pressure applications for connecting hydraulic lines up to DN51 (2").

Coupling (screwing) and uncoupling (unscrewing) of the two halves is safe and very easy. After the connection is complete, all internal components have minimal play or clearance, which significantly reduces the risk of material fatigue.

Another advantage is that the risk of permanent indentation, so-called "brinelling", on the surface of the male tip is eliminated, which can occur with push-to-connect couplings in similar extreme applications.

The proven design is suitable for use in high pressure applications and available in nominal sizes 10, 12,5, 19, 25, 31, 38, 51 (3/8" - 2").

Features

- Poppet Valve
- Coupling made from carbon steel with Zinc/Nickel surface coating
- Connect under pressure
- Heavy duty internal components
- Wide of range for normal sizes up to DN51 (2")

Applications

High Pressure Applications

Top Features

Zinc/Nickel coating



Vibration resistant



Connect Under pressure



Designed for secure connection

HH

Series HH ▪ Carbon Steel

Material	Carbon Steel
Surface Finishing	Zinc-Nickel
Standard Seal Material(s)	NBR (Buna-N®) ²
Working Temperature	-25° C ... +100° C / -13° F ... +212° F
Valve Design	Poppet Valve
Connection	Screw
Disconnection	Screw
Connect Under Pressure	Male Tip or Female Body allowed
Application	Industrial Hydraulic, Rescue and Tensioning Hydraulics
ISO Interchange	-



² Alternative seal materials are available on request.

Technical Data

Series	BG	DN Zoll	DN metric ISO 4397	Q _{max}		Working Pressure		Bursting Pressure Connected		Female Body		Male Tip		Spillage	
				l/min	US GPM	bar	PSI	bar	PSI	bar	PSI	bar	PSI	ml	fl oz
HH-10	2	3/8"	10	27	7.13	650	9427	3000	43511	3000	43511	3000	43511	1,9	.0642
HH-12	3	1/2"	12,5	60	15.85	600	8702	2200	31908	2700	39160	2500	36260	2,7	.0913
HH-19	4	3/4"	19 (20)	82,5	21.79	500	7252	2100	30458	2600	37710	2400	34809	9,3	.3145
HH-25	6	1"	25	150	39.63	460	6672	2000	29008	2600	37710	2300	33359	16	.5410
HH-31	8	1 1/4"	31	210	55.48	360	5221	1500	21756	1500	21756	1500	21756	30	10.144
HH-38	10	1 1/2"	38	400	105.67	360	5221	1500	21756	1500	21756	1200	17405	54	18.260
HH-51	12	2"	51	1500	396.26	210	3046	1500	21756	1500	21756	1200	17405	120	40.577

The indicated pressure ratings only apply to the coupling itself and depend on the connection type.

Flow Characteristics

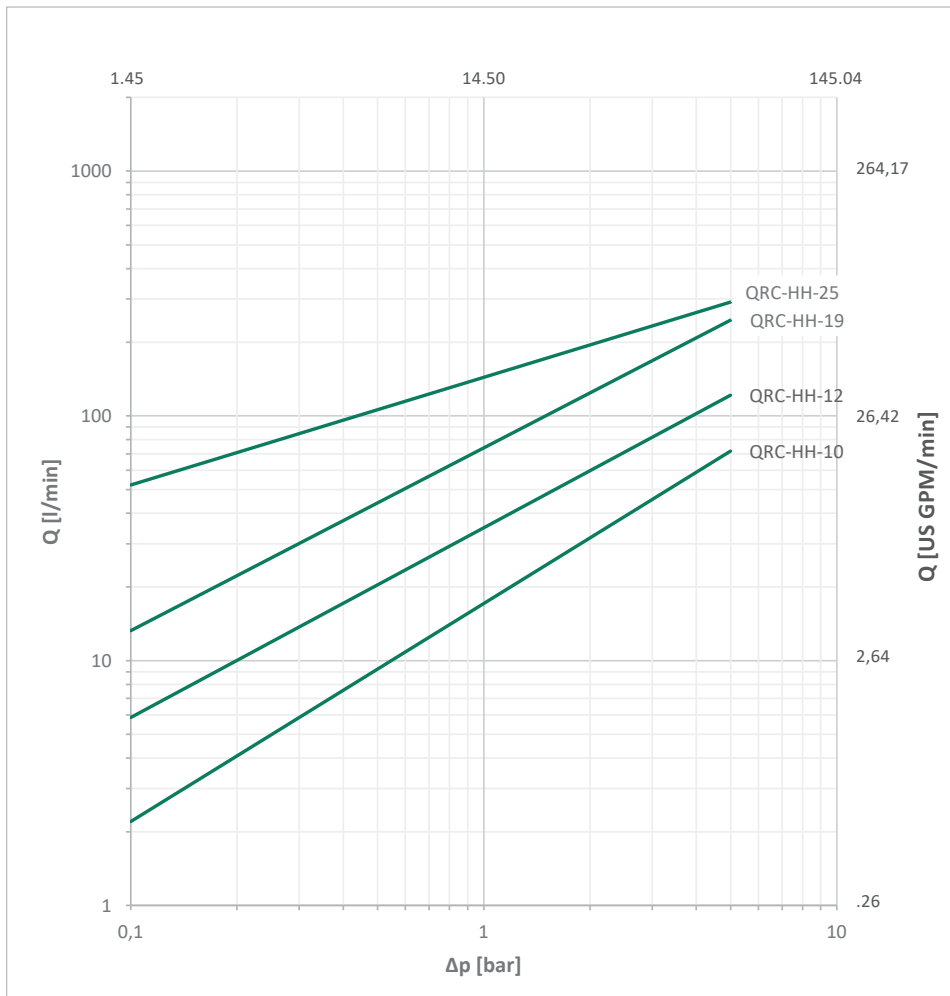

Please note: Unless otherwise stated, all flow characteristics have been determined with hydraulic oil with a kinematic viscosity of 28,8 - 35,2 mm²/s (28,8 - 35,2 cSt) and are only valid for components with non-reducing connections.



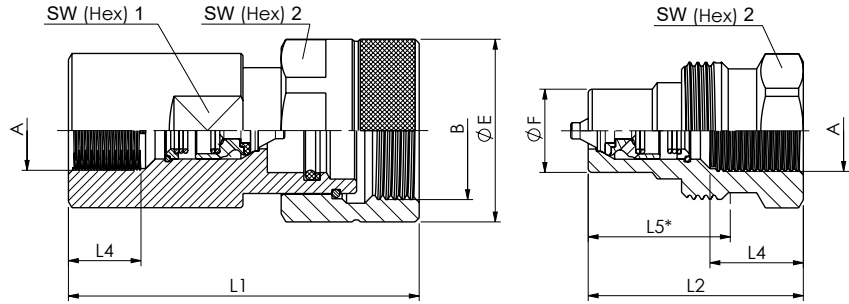

SW: Width across flats. All dimensions in mm (inch). Drawing similar Series HH-12.
* Insertion Male Tip.

Series HH-10 • BG 2 • Nominal Size 10

Port A	Dimensions (mm/in)											Female Body	Weight (kg/lbs) ca. per 100	Male Tip	Weight (kg/lbs) ca. per 100
	ØE	ØF	B	L1	L2	L4 min	L5	SW1	SW2	SW3	Ordering Codes				
Female Thread according to DIN 3852 - ISO 1179-1 - ANSI B 1.20.3															
	G 3/8"	40 .16	18,9 .74	1 1/4" - 8 UN	75,6 2.98	48 1.89	16 .63	34 1.34	30 1.18	32 1.26	36 1.42	QRC-HH-10-F-G06-BT-W3	36,86 81.26	QRC-HH-10-M-G06-B-W3	15,07 34.17
	NPTF 3/8" -18	40 .16	18,9 .74	1 1/4" - 8 UN	75,6 2.98	48 1.89		34 1.34	30 1.18	32 1.26	36 1.42	QRC-HH-10-F-NF06-BT-W3	34,60 76.28	QRC-HH-10-M-NF06-B-W3	15,70 34.61

Series HH-12 • BG 3 • Nominal Size 12,5

Port A	Dimensions (mm/in)											Female Body	Weight (kg/lbs) ca. per 100	Male Tip	Weight (kg/lbs) ca. per 100
	ØE	ØF	B	L1	L2	L4 min	L5	SW1	SW2	SW3	Ordering Codes				
Female Thread according to DIN 3852 - ISO 1179-1 - ANSI B 1.20.3															
	G 1/2"	45 1.77	20,5 .81	1 3/8" - 8 UN	86,4 3.40	53 2.09	18 .71	37,2 1.46	34 1.34	34 1.34	41 1.61	QRC-HH-12-F-G08-BT-W3	56,70 125.00	QRC-HH-12-M-G08-B-W3	18,82 41.49
	NPTF 1/2" -14	45 1.77	20,5 .81	1 3/8" - 8 UN	86,4 3.40	53 2.09		37,2 1.46	34 1.34	34 1.34	41 1.61	QRC-HH-12-F-NF08-BT-W3	58,20 128.31	QRC-HH-12-M-NF08-B-W3	18,00 39.68

Series HH-19 • BG 4 • Nominal Size 19

Port A	Dimensions (mm/in)											Female Body	Weight (kg/lbs) ca. per 100	Male Tip	Weight (kg/lbs) ca. per 100
	ØE	ØF	B	L1	L2	L4 min	L5	SW1	SW2	SW3	Ordering Codes				
Female Thread according to DIN 3852 - ISO 1179-1 - ANSI B 1.20.3															
	G 3/4"	53,8 2.12	27,9 1.10	1 3/4" - 6 UN	105,5 4.15	63 2.48	21 0.83	47,3 1.86	41 1.61	46 1.81	50 1.97	QRC-HH-19-F-G12-BT-W3	93,00 205.03	QRC-HH-19-M-G12-B-W3	36,80 80.25
	NPTF 3/4" -14	53,8 2.12	27,9 1.10	1 3/4" - 6 UN	105,5 4.15	63 2.48		47,3 1.86	41 1.61	46 1.81	50 1.97	QRC-HH-19-F-NF12-BT-W3	99,70 219.80	QRC-HH-19-M-NF12-B-W3	37,30 82.23

Series HH-25 • BG 6 • Nominal Size 25

Port A	Dimensions (mm/in)											Female Body	Weight (kg/lbs) ca. per 100	Male Tip	Weight (kg/lbs) ca. per 100
	ØE	ØF	B	L1	L2	L4 min	L5	SW1	SW2	SW3	Ordering Codes				
Female Thread according to DIN 3852 - ISO 1179-1 - ANSI B 1.20.3															
	G 1"	59 2.32	31,3 1.23	M52x4	123 4.84	72 2.83	23 .91	56,5 2.22	50 1.97	50 1.97	55 2.17	QRC-HH-25-F-G16-BT-W3	137,90 309.31	QRC-HH-25-M-G16-B-W3	51,70 113.98
	NPTF 1" -11 1/2	59 2.32	31,3 1.23	M52x4	123 4.84	72 2.83		56,5 2.22	50 1.97	50 1.97	55 2.17	QRC-HH-25-F-NF16-BT-W3	148,10 326.50	QRC-HH-25-M-NF16-B-W3	54,00 119.05

Note: The connection of the two halves of a coupling is achieved depending on the type. It is important to observe the positive engagement of plug-type couplings and the secure tightening of screw-type couplings to the limit stop of the thread. Forced or improper separation will result in malfunction of the coupling.



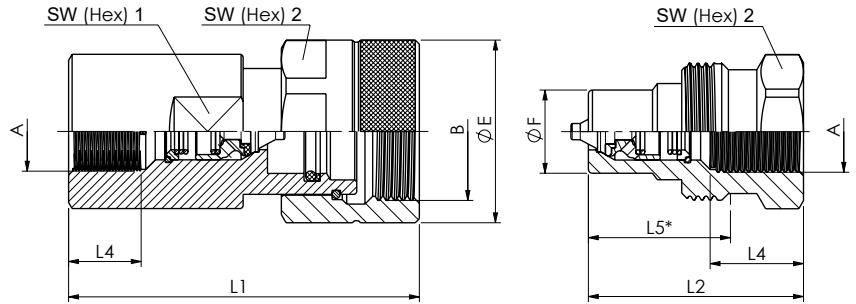

Series HH-31 • BG 8 • Nominal Size 31,5

Port A	Dimensions (mm/in)										Female Body	Weight (kg/lbs) ca. per 100	Male Tip	Weight (kg/lbs) ca. per 100	
	ØE	ØF	B	L1	L2	L4 min	L5	SW1	SW2	SW3					Ordering Codes
Female Thread according to DIN 3852 - ISO 1179-1 - ANSI B 1.20.3															
	G 1 1/4"	78,5	43,9	M68x6	152,5	86	24	71,3	65	65	75	QRC-HH-31-F-G20-BT-W3	292,60	QRC-HH-31-M-G20-B-W3	105,50
		3,09	1,73		6,01	3,39	.94	2,81	2,56	2,56	2,95		632,73		231,49
	NPTF 1 1/4"	78,5	43,9	M68x6	152,5	86		71,3	65	65	75	QRC-HH-31-F-NF20-BT-W3	295	QRC-HH-31-M-NF20-B-W3	109,20
	-11 1/2	3,09	1,73		6,01	3,39		2,81	2,56	2,56	2,95		650,36		240,74

Series HH-38 • BG 10 • Nominal Size 38

Port A	Dimensions (mm/in)										Female Body	Weight (kg/lbs) ca. per 100	Male Tip	Weight (kg/lbs) ca. per 100	
	ØE	ØF	B	L1	L2	L4 min	L5	SW1	SW2	SW3					Ordering Codes
Female Thread according to DIN 3852 - ISO 1179-1 - ANSI B 1.20.3															
	G 1 1/2"	98	53,4	M78x6	172	95	27	79	75	80	90	QRC-HH-38-F-G24-BT-W3	444,40	QRC-HH-38-M-G24-B-W3	173,70
		3,86	2,10		6,77	3,74	1,06	3,11	2,95	3,15	3,54		978,85		374,79
	NPTF 1 1/2"	98	53,4	M78x6	172	95		79	75	80	90	QRC-HH-38-F-NF24-BT-W3	447	QRC-HH-38-M-NF24-B-W3	172
	-11 1/2	3,86	2,10		6,77	3,74		3,11	2,95	3,15	3,54		985,47		379,20

Series HH-51 • BG 12 • Nominal Size 51

Port A	Dimensions (mm/in)										Female Body	Weight (kg/lbs) ca. per 100	Male Tip	Weight (kg/lbs) ca. per 100	
	ØE	ØF	B	L1	L2	L4 min	L5	SW1	SW2	SW3					Ordering Codes
Female Thread according to DIN 3852 - ISO 1179-1 - ANSI B 1.20.3															
	G 2"	129	81,8	M115x8	206,5	118	27	97,1	100	110	125	QRC-HH-51-F-G32-BT-W3	856,50	QRC-HH-51-M-G32-B-W3	492,80
		5,07	3,22		8,13	4,65	1,06	3,82	3,94	4,33	4,92		1888,26		1086,88
	NPTF 2" -11 1/2	129	81,8	M115x8	206,5	118		97,1	100	110	125	QRC-HH-51-F-NF32-BT-W3	892,00	QRC-HH-51-M-NF32-B-W3	507
		5,07	3,22		8,13	4,65		3,82	3,94	4,33	4,92		1966,52		1117,74

Note: The connection of the two halves of a coupling is achieved depending on the type. It is important to observe the positive engagement of plug-type couplings and the secure tightening of screw-type couplings to the limit stop of the thread. Forced or improper separation will result in malfunction of the coupling.

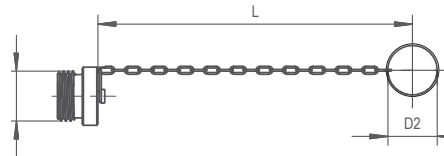
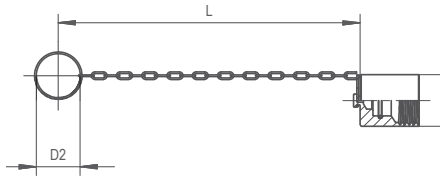

Series HH • Dust Protection

Dimensions (mm/in)			Material	Dust Cap for Male Tip
D1	D2	L		Ordering Codes
34	30	240	Aluminium with chain	QRC-HH-10-DM-30/CN-W89-SI
1.34	1.18	9.45		
38	30	240	Aluminium with chain	QRC-HH-12-DM-30/CN-W89-SI
1.50	1.18	9.45		
48	41	290	Aluminium with chain	QRC-HH-19-DM-41/CN-W89-SI
1.89	1.61	11.42		
58	48	300	Aluminium with chain	QRC-HH-25-DM-48/CN-W89-SI
2.28	1.89	11.81		
81	48	400	Aluminium with chain	QRC-HH-31-DM-48/CN-W89-SI
3.19	1.89	15.75		
85	46	260	Aluminium with chain	QRC-HH-38-DM-46/CN-W89-SI
3.35	1.81	10.24		
100	46	300	Aluminium with chain	QRC-HH-51-DM-46/CN-W89-SI
3.94	1.81	11.81		

Dimensions (mm/in)			Material	Dust Plug for Female Body
D1	D2	L		Ordering Codes
34	30	190	Aluminium with chain	QRC-HH-10-DF-30/CN-W89-SI
1.34	1.18	7.48		
34	30	240	Aluminium with chain	QRC-HH-12-DF-30/CN-W89-SI
1.34	1.18	9.45		
53	48	300	Aluminium with chain	QRC-HH-19-DF-48/CN-W89-SI
2.09	1.89	11.81		
53	41	290	Aluminium with chain	QRC-HH-25-DF-41/CN-W89-SI
2.09	1.61	11.42		
71	48	400	Aluminium with chain	QRC-HH-31-DF-48/CN-W89-SI
2.80	1.89	15.75		
98	46	210	Aluminium with chain	QRC-HH-38-DF-46/CN-W89-SI
3.86	1.81	8.27		
115	46	270	Aluminium with chain	QRC-HH-51-DF-46/CN-W89-SI
4.53	1.81	10.63		

HH

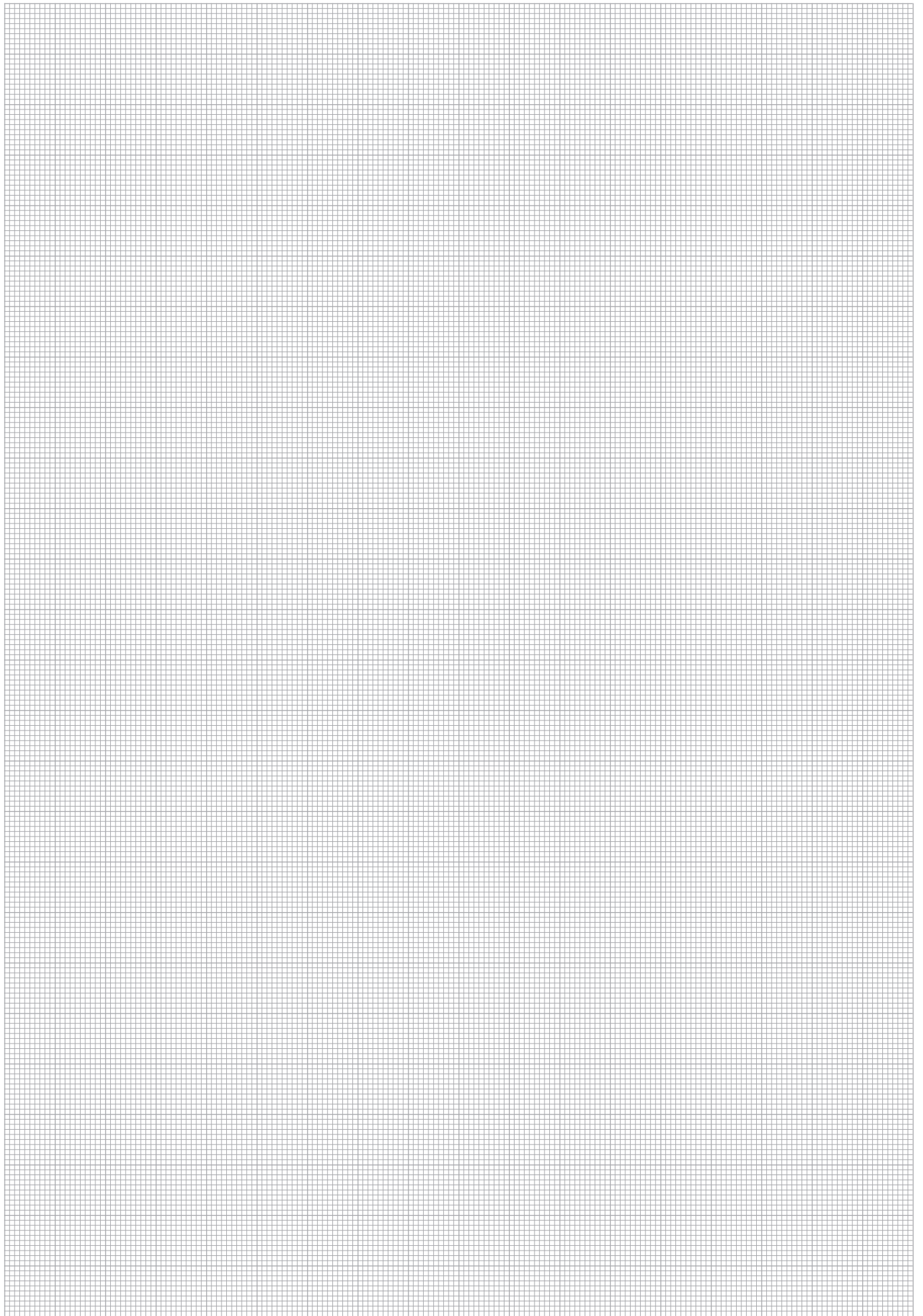
HH



Series HH • Stainless Steel
Product Description

Screw-to-connect couplings of the HH Series made of stainless steel from STAUFF consist of a female body with a screw sleeve and a male tip with external thread. The Series is developed for high working pressure applications for connecting hydraulic lines up to DN51 (2").

Coupling (screwing) and uncoupling (unscrewing) of the two halves is safe and very easy. After the connection is complete, all internal components have minimal play or clearance, which significantly reduces the risk of material fatigue.

Another advantage is that the risk of permanent indentation, so-called "brinelling", on the surface of the male tip is eliminated, which can occur with push-to-connect couplings in similar extreme applications.

The proven design is suitable for use in high pressure applications and available in nominal sizes 10, 12,5, 19, 25, 31, 38, 51 (3/8" - 2").

Features

- Poppet Valve
- Coupling made of stainless steel
- Connect under pressure
- Heavy duty internal components
- Wide of range for normal sizes up to DN51 (2")

Applications

High Pressure Applications

Top Features

Connect Under pressure



Designed for secure connection



HH



Series HH ▪ Stainless Steel

Material	Stainless Steel V4A (AISI 316)
Surface Finishing	-
Standard Seal Material(s)	FKM (Viton®) ²
Working Temperature	-25° C ... +200° C / -13° F ... +392° F
Valve Design	Poppet Valve
Connection	Screw
Disconnection	Screw
Connect Under Pressure	Male Tip or Female Body allowed
Application	Industrial Hydraulic, Offshore, Rescue and Tensioning Hydraulics
ISO Interchange	-



² Alternative seal materials are available on request.

Technical Data

Series	BG	DN Zoll Inch	DN metric ISO 4397	Q _{max}		Working Pressure		Bursting Pressure Connected		Female Body		Male Tip		Spillage	
				l/min	US GPM	bar	PSI	bar	PSI	bar	PSI	bar	PSI	ml	fl oz
HH-10	2	3/8"	10	18	4.76	650	9427	2200	31908	2400	34809	2200	31908	1,9	.0642
HH-12	3	1/2"	12,5	23	6.08	600	8702	2100	30458	2000	29008	1600	23206	2,7	.0913
HH-19	4	3/4"	19 (20)	45	11.89	500	7252	2000	29007	3000	43511	2800	40611	9,3	.3145
HH-25	6	1"	25	106	28.00	460	6672	1600	23206	1800	26107	1600	23206	16	.5410
HH-31	8	1 1/4"	31	189	49.93	400	5802	1400	20305	1900	27557	1600	23206	30	10.144
HH-38	10	1 1/2"	38	300	79.25	360	5221	1700	24656	1700	24656	1700	24656	54	18.260
HH-51	12	2"	51	757	199.98	210	3046	1050	15229	1600	23206	1400	20305	120	40.577

The indicated pressure ratings only apply to the coupling itself and depend on the connection type.

Flow Characteristics

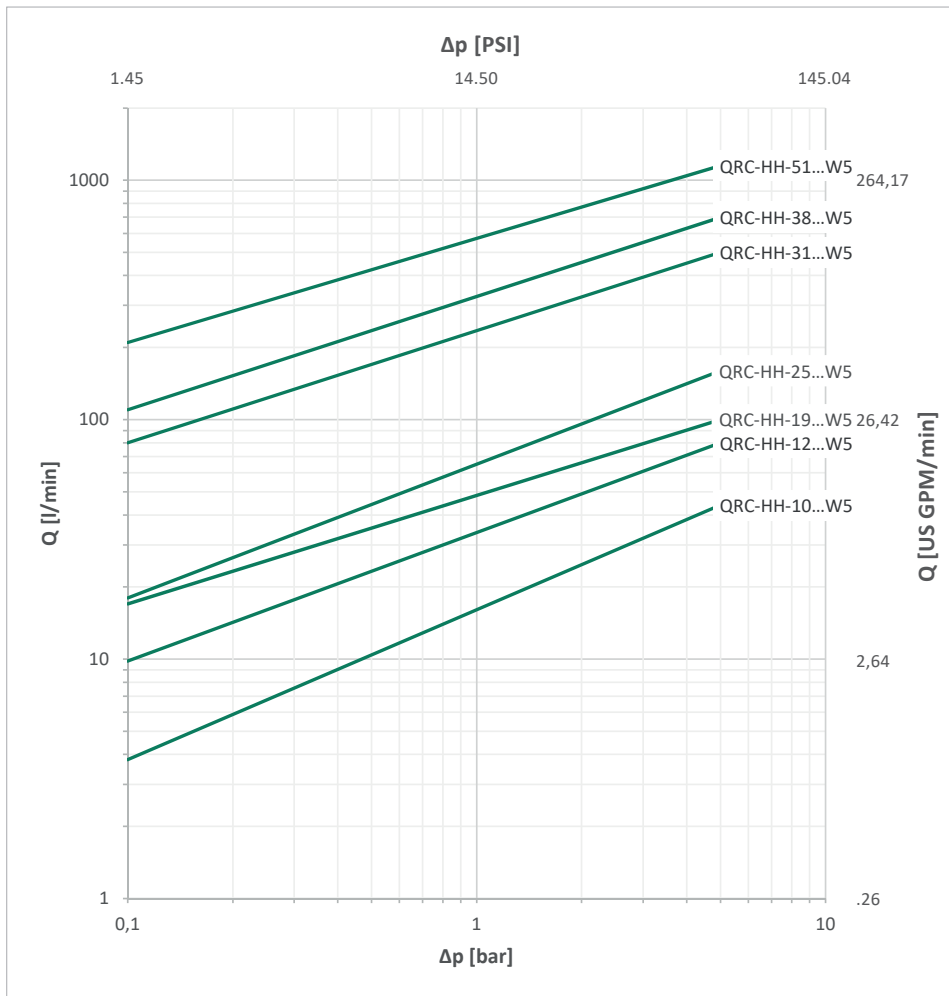

Please note: Unless otherwise stated, all flow characteristics have been determined with hydraulic oil with a kinematic viscosity of 28,8 - 35,2 mm²/s (28,8 - 35,2 cSt) and are only valid for components with non-reducing connections.



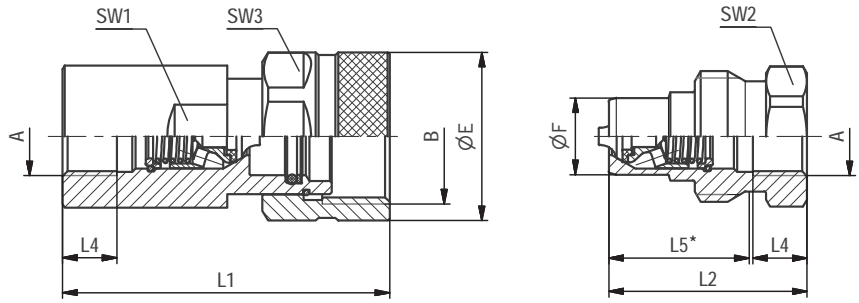

SW: Width across flats. All dimensions in mm (inch). Drawing similar Series HH-12.
* Insertion Male Tip.

Series HH-10 • BG 2 • Nominal Size 10

Port A	Dimensions (mm/inch)											Female Body	Weight (kg/lbs) ca. per 100	Male Tip	Weight (kg/lbs) ca. per 100
	ØE	ØF	B	L1	L2	L4 min	L5	SW1	SW2	SW3	Ordering Codes				
Female Thread according to DIN 3852 - ISO 1179-1 - ANSI B 1.20.3															
	G 3/8"	39 1.54	18,9 0,74	1 1/4" - 8 UN	76 2.99	48 1.89	14 .55	34 1.34	30 1.18	32 1.26	36 1.42	QRC-HH-10-F-G06-VT-W5	38,15 84.11	QRC-HH-10-M-G06-V-W5	15,47 34.11
	NPTF 3/8" -18	39 1,54	18,9 0,74	1 1/4" - 8 UN	76 2.99	48 1.89		34 1.34	30 1.18	32 1.26	36 1.42	QRC-HH-10-F-NF06-VT-W5	36,10 79.59	QRC-HH-10-M-NF06-V-W5	15,74 34.70

Series HH-12 • BG 3 • Nominal Size 12,5

Port A	Dimensions (mm/inch)											Female Body	Weight (kg/lbs) ca. per 100	Male Tip	Weight (kg/lbs) ca. per 100
	ØE	ØF	B	L1	L2	L4 min	L5	SW1	SW2	SW3	Ordering Codes				
Female Thread according to DIN 3852 - ISO 1179-1 - ANSI B 1.20.3															
	G 1/2"	45 1.77	20,5 .81	1 3/8" - 8 UN	86,4 3.40	53 2.09	18 .71	37,5 1.48	34 1.34	34 1.34	41 1.61	QRC-HH-12-F-G08-VT-W5	59,25 130.62	QRC-HH-12-M-G08-V-W5	19,26 42.46
	NPTF 1/2" -14	45 1.77	20,5 .81	1 3/8" - 8 UN	86,4 3.40	53 2.09		37,5 1.48	34 1.34	34 1.34	41 1.61	QRC-HH-12-F-NF08-VT-W5	59,84 131.92	QRC-HH-12-M-NF08-V-W5	19,55 43.10

Series HH-19 • BG 4 • Nominal Size 19

Port A	Dimensions (mm/inch)											Female Body	Weight (kg/lbs) ca. per 100	Male Tip	Weight (kg/lbs) ca. per 100
	ØE	ØF	B	L1	L2	L4 min	L5	SW1	SW2	SW3	Ordering Codes				
Female Thread according to DIN 3852 - ISO 1179-1 - ANSI B 1.20.3															
	G 3/4"	53,8 2.12	27,9 1.10	1 3/4" - 6 UN	105,5 4.15	63 2.48	21,5 .85	48 1.89	41 1.61	46 1.81	50 1.97	QRC-HH-19-F-G12-VT-W5	94,88 209.17	QRC-HH-19-M-G12-V-W5	37,6 82.89
	NPTF 3/4" -14	53,8 2.12	27,9 1.10	1 3/4" - 6 UN	105,5 4.15	63 2.48		48 1.89	41 1.61	46 1.81	50 1.97	QRC-HH-19-F-NF12-VT-W5	95,75 211.09	QRC-HH-19-M-NF12-V-W5	38,51 84.90

Series HH-25 • BG 6 • Nominal Size 25

Port A	Dimensions (mm/inch)											Female Body	Weight (kg/lbs) ca. per 100	Male Tip	Weight (kg/lbs) ca. per 100
	ØE	ØF	B	L1	L2	L4 min	L5	SW1	SW2	SW3	Ordering Codes				
Female Thread according to DIN 3852 - ISO 1179-1 - ANSI B 1.20.3															
	G 1"	58,8 2.31	31,3 1.23	M52x4	123 4.84	72 2.83	21,5 .85	56 2.20	50 1.97	50 1.97	55 2.17	QRC-HH-25-F-G16-VT-W5	142,03 313.12	QRC-HH-25-M-G16-V-W5	53,84 118.70
	NPTF 1" -11 1/2	58,8 2.31	31,3 1.23	M52x4	123 4.84	72 2.83		56 2.20	50 1.97	50 1.97	55 2.17	QRC-HH-25-F-NF16-VT-W5	149,11 328.73	QRC-HH-25-M-NF16-V-W5	55,02 121.30

HH

Note: The connection of the two halves of a coupling is achieved depending on the type. It is important to observe the positive engagement of plug-type couplings and the secure tightening of screw-type couplings to the limit stop of the thread. Forced or improper separation will result in malfunction of the coupling.



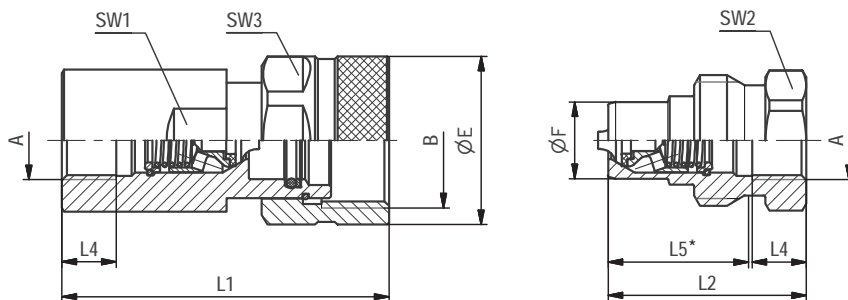

SW: Width across flats. All dimensions in mm (inch). Drawing similar Series HH-12.
* Insertion Male Tip.

Series HH-31 ▪ BG 8 ▪ Nominal Size 31,5

Port A	Dimensions (mm/in)										Female Body	Weight (kg/lbs) ca. per 100	Male Tip	Weight (kg/lbs) ca. per 100	
	ØE	ØF	B	L1	L2	L4 min	L5	SW1	SW2	SW3					Ordering Codes
Female Thread according to DIN 3852 - ISO 1179-1 - ANSI B 1.20.3															
	G 1 1/4"	80	44	M68x6	153	86	20	72	65	65	75	QRC-HH-31-F-G20-VT-W5	293,30	QRC-HH-31-M-G20-V-W5	107,40
		3.15	1.73		6.02	3.39	.79	2.83	2.56	2.56	2.95		646.62		236.78
	NPTF 1 1/4"	80	44	M68x6	153	86		72	65	65	75	QRC-HH-31-F-NF20-VT-W5	295	QRC-HH-31-M-NF20-V-W5	109,20
	-11 1/2	3.15	1.73		6.02	3.39		2.83	2.56	2.56	2.95		650.36		240.74

Series HH-38 ▪ BG 10 ▪ Nominal Size 38

Port A	Dimensions (mm/in)										Female Body	Weight (kg/lbs) ca. per 100	Male Tip	Weight (kg/lbs) ca. per 100	
	ØE	ØF	B	L1	L2	L4 min	L5	SW1	SW2	SW3					Ordering Codes
Female Thread according to DIN 3852 - ISO 1179-1 - ANSI B 1.20.3															
	G 1 1/2"	98	53,4	M78x6	172	95	22	80	75	80	90	QRC-HH-38-F-G24-VT-W5	455	QRC-HH-38-M-G24-V-W5	173,40
		3.86	2.10		6.77	3.74	.87	3.15	2.95	3.15	3.54		1003.10		382.28
	NPTF 1 1/2"	98	53,4	M78x6	172	95		80	75	80	90	QRC-HH-38-F-NF24-VT-W5	457	QRC-HH-38-M-NF24-V-W5	173
	-11 1/2	3.86	2.10		6.77	3.74		3.15	2.95	3.15	3.54		1007.51		381.40

Series HH-51 ▪ BG 12 ▪ Nominal Size 51

Port A	Dimensions (mm/in)										Female Body	Weight (kg/lbs) ca. per 100	Male Tip	Weight (kg/lbs) ca. per 100	
	ØE	ØF	B	L1	L2	L4 min	L5	SW1	SW2	SW3					Ordering Codes
Female Thread according to DIN 3852 - ISO 1179-1 - ANSI B 1.20.3															
	G 2"	129	81,8	M115x8	205	118	24	96	100	110	125	QRC-HH-51-F-G32-VT-W5	888	QRC-HH-51-M-G32-V-W5	503
		5.07	3.22		8.07	4.65	.94	3.78	3.93	4.33	4.92		1957.71		1108.93
	NPTF 2" -11	129	81,8	M115x8	205	118		96	100	110	125	QRC-HH-51-F-NF32-VT-W5	892	QRC-HH-51-M-NF32-V-W5	507
	1/2	5.07	3.22		8.07	4.65		3.78	3.93	4.33	4.92		1966.52		1117.74

Note: The connection of the two halves of a coupling is achieved depending on the type. It is important to observe the positive engagement of plug-type couplings and the secure tightening of screw-type couplings to the limit stop of the thread. Forced or improper separation will result in malfunction of the coupling.

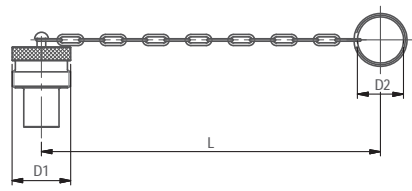
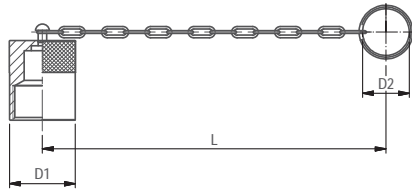

Series HH • Dust Protection

Dimensions (mm/in)			Material	Dust Cap for Male Tip
D1	D2	L		Ordering Codes
34	30	240	Aluminium with chain	QRC-HH-10-DM-30/CN-W89-SI
1.34	1.18	9.45		
38	30	240	Aluminium with chain	QRC-HH-12-DM-30/CN-W89-SI
1.50	1.18	9.45		
48	41	290	Aluminium with chain	QRC-HH-19-DM-41/CN-W89-SI
1.89	1.61	11.42		
58	48	300	Aluminium with chain	QRC-HH-25-DM-48/CN-W89-SI
2.28	1.89	11.81		
81	48	400	Aluminium with chain	QRC-HH-31-DM-48/CN-W89-SI
3.19	1.89	15.75		
85	46	260	Aluminium with chain	QRC-HH-38-DM-46/CN-W89-SI
3.35	1.81	10.24		
100	46	300	Aluminium with chain	QRC-HH-51-DM-46/CN-W89-SI
3.94	1.81	11.81		

Dimensions (mm/in)			Material	Dust Plug for Female Body
D1	D2	L		Ordering Codes
34	30	240	Aluminium with chain	QRC-HH-10-DF-30/CN-W89-SI
1.34	1.18	9.45		
34	30	240	Aluminium with chain	QRC-HH-12-DF-30/CN-W89-SI
1.34	1.18	9.45		
53	48	300	Aluminium with chain	QRC-HH-19-DF-48/CN-W89-SI
2.09	1.89	11.81		
53	41	290	Aluminium with chain	QRC-HH-25-DF-41/CN-W89-SI
2.09	1.61	11.42		
71	48	400	Aluminium with chain	QRC-HH-31-DF-48/CN-W89-SI
2.80	1.89	15.75		
98	46	210	Aluminium with chain	QRC-HH-38-DF-46/CN-W89-SI
3.86	1.81	8.27		
115	46	270	Aluminium with chain	QRC-HH-51-DF-46/CN-W89-SI
4.53	1.81	10.63		

HH

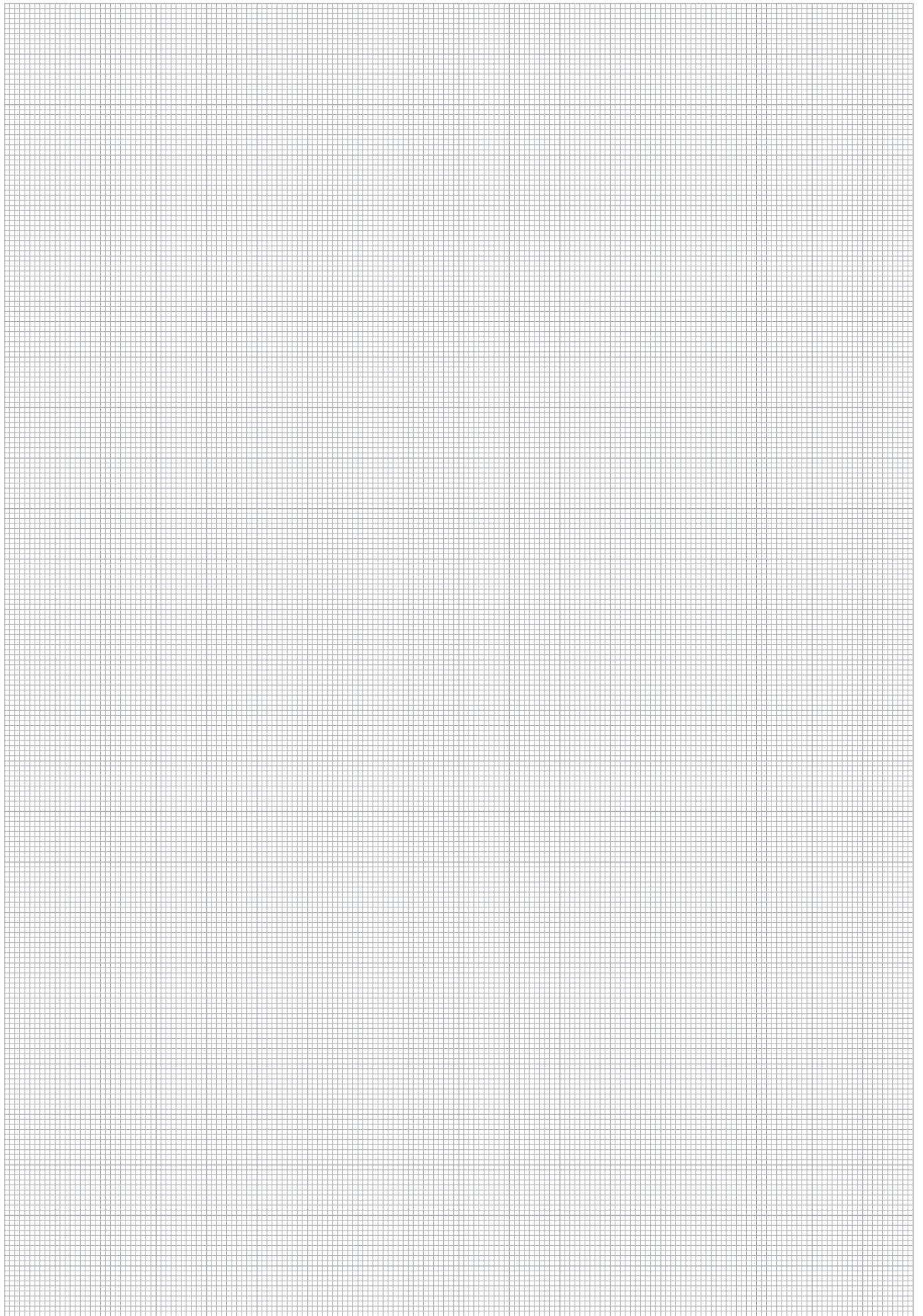
HH



Series HI - Carbon Steel
Product Description

Screw-to-connect couplings of the HI Series from STAUFF consist of a female body with a screw sleeve and a male tip with external thread. The Series is developed for high working pressure applications according to ISO 14540 and can be connected under residual pressure.

Coupling (screwing) and uncoupling (unscrewing) of the two halves is safe and very easy. After the connection is complete, all internal components have minimal play or clearance, which significantly reduces the risk of material fatigue.

Another advantage is that the risk of permanent indentation, so-called "brinelling", on the surface of the male tip is eliminated, which can occur with push-to-connect couplings in similar extreme applications.

The proven design is suitable for use in high pressure applications, such as cylinders and hydraulic tools and available in nominal sizes 6,3, 10 (1/4" - 3/8").

Features

- Poppet Valve (HI) or Ball Valve (HIB)
- Coupling made from carbon steel with Zinc/Nickel surface coating
- Connect under residual pressure
- ISO Interchange acc. to ISO 14540

Applications

High Pressure Applications

Top Features

Zinc/Nickel coating



Vibration resistant



Connect Under residual pressure



Designed for secure connection



HI



Series HI (HIB) • Carbon Steel

Material	Carbon Steel
Surface Finishing	Zinc-Nickel
Standard Seal Material(s)	NBR (Buna-N®), PU ²
Working Temperature	-25° C ... +100° C / -13° F ... +212° F
Valve Design	Poppet Valve (HI), Ball Valve (HIB) (optional)
Connection	Screw
Disconnection	Screw
Connect Under Pressure	not allowed
Application	Industrial Hydraulic, Rescue and Tensioning Hydraulics
ISO Interchange	ISO 14540



² Alternative seal materials are available on request.

Technical Data

Series	BG	DN Zoll	DN metric ISO 4397	Q _{max}		Working Pressure		Bursting Pressure Connected		Female Body		Male Tip		Spillage	
				l/min	US GPM	bar	PSI	bar	PSI	bar	PSI	bar	PSI	ml	fl oz
HI-06	1	1/4"	6,3	18	4.76	720	10443	2160	31328	2160	31328	2160	31328	0,5	.0176
HI-10	2	3/8"	10	34,5	9.11	720	10443	2160	31328	2160	31328	2160	31328	1	.0352
HIB-06	1	1/4"	6,3	18	4.76	720	10443	2160	31328	1440	20885	1440	20885	0,5	.0176
HIB-10	2	3/8"	10	34,5	9.11	720	10443	2160	31328	1440	20885	1440	20885	1	.0352

The indicated pressure ratings only apply to the coupling itself and depend on the connection type.

Flow Characteristics

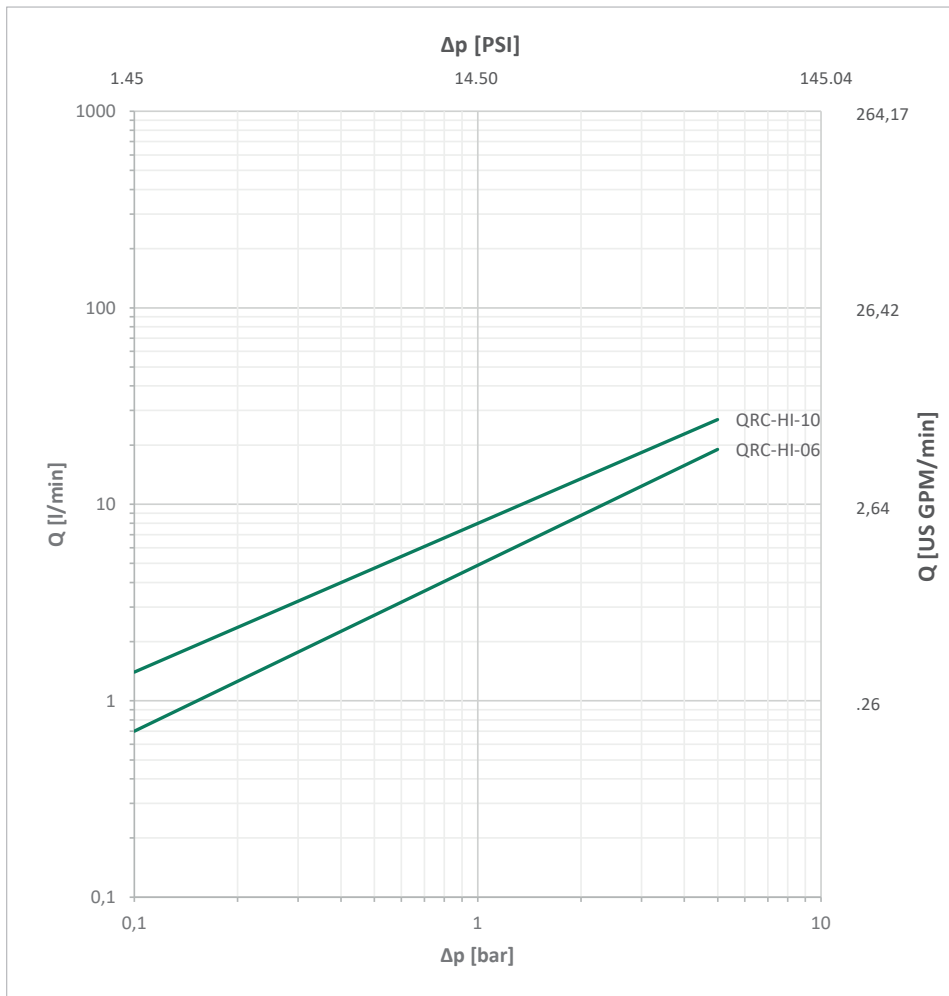



Please note: Unless otherwise stated, all flow characteristics have been determined with hydraulic oil with a kinematic viscosity of 28,8 - 35,2 mm²/s (28,8 - 35,2 cSt) and are only valid for components with non-reducing connections.

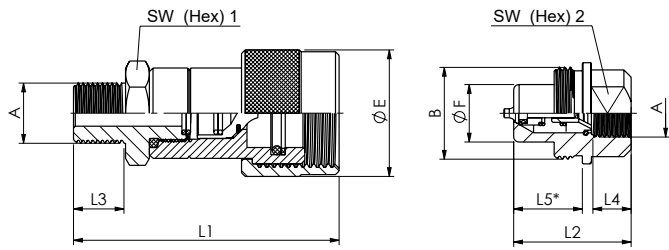

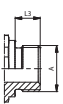

SW: Width across flats. All dimensions in mm (inch). Drawing similar Series HI-10.
* Insertion Male Tip.

Series HI-06 ▪ BG 1 ▪ Nominal Size 6,3

Port A	Dimensions (mm/in)									Female Body Ordering Codes	Weight (^{kg} /lbs) ca. per 100	Male Tip Ordering Codes	Weight (^{kg} /lbs) ca. per 100	
	ØE	ØF	B	L1	L2	L4 min	L5	SW1	SW2					
Male Thread according to ANSI B 1.20.3														
	NPTF 1/4" -18	28,6 1.13	15,9 .63	1" - 18 UNS	59,7 2.35	32,5 1.28		19 .75	22 .87	19 .75	QRC-HI-06-F-NF04M-S1-W3	11,56 25.49		
	Female Thread according to DIN 3852 - ISO 1179-1 - ANSI B 1.20.3													
	G 1/4"	28,6 1.13	15,9 .63	1" - 18 UNS	59,7 2.35	32,5 1.28	12 .47	19 .75	22 .87	19 .75	QRC-HI-06-F-G04-S1-W3	11,39 25.11	QRC-HI-06-M-G04-BP-W3	7,05 15.54
	NPTF 1/4" -18	28,6 1.13	15,9 .63	1" - 18 UNS	59,7 2.35	32,5 1.28		19 .75	22 .87	19 .75	QRC-HI-06-F-NF04-S1-W3	11,56 25.49	QRC-HI-06-M-NF04-BP-W3	7,12 15.70

Series HI-10 ▪ BG 2 ▪ Nominal Size 10

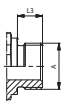
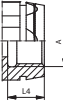
Port A	Dimensions (mm/in)									Female Body Ordering Codes	Weight (^{kg} /lbs) ca. per 100	Male Tip Ordering Codes	Weight (^{kg} /lbs) ca. per 100	
	ØE	ØF	B	L1	L2	L4 min	L5	SW1	SW2					
Male Thread according to ANSI B 1.20.3														
	NPTF 3/8" -18	35 1.38	19 .75	1" 3/16-16UN	73,5 2.89			25 .98	25 .98	32 1.26	QRC-HI-10-F-NF06M-S1-W3	23,21 51.17		
	Female Thread according to ANSI B 1.20.3													
	NPTF 3/8" -18	35 1.38	19 .75	1" 3/16-16UN		35 1.38		25 .98	25 .98	32 1.26			QRC-HI-10-M-NF06-BP-W3	11,38 25.09

In addition to the version with poppet valve is a version with ball valve available. Please use for these version the code HIB instead of HI.

HI

Note: The connection of the two halves of a coupling is achieved depending on the type. It is important to observe the positive engagement of plug-type couplings and the secure tightening of screw-type couplings to the limit stop of the thread. Forced or improper separation will result in malfunction of the coupling.



Series HI• Dust Protection

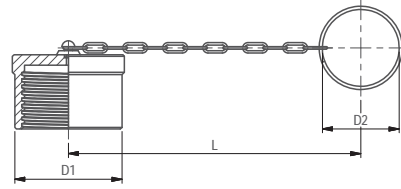
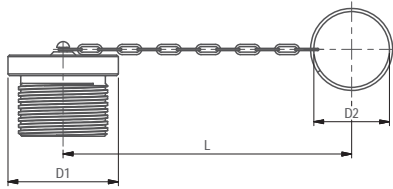

Dimensions (mm/in)			Material	Dust Plug for Female Body
D1	D2	L		Ordering Codes
28,6	14	161	Carbon Steel with chain	QRC-HI-06-DM-14/CN-W3
1.13	.55	6.34		
35	14	161	Carbon Steel with chain	QRC-HI-10-DF-14/CN-W3
1.38	.55	6.34		

Dimensions (mm/in)			Material	Dust Cap for Male Tip
D1	D2	L		Ordering Codes
28	14	161	Carbon Steel with chain	QRC-HI-06-DF-14/CN-W3
1.10	.55	6.34		
35	14	161	Carbon Steel with chain	QRC-HI-10-DM-14/CN-W3
1.38	.55	6.34		

* Available on request.



Series HT - Carbon Steel
Product Description

Screw-to-connect couplings of the HT Series from STAUFF consist of a female body with a winged screw sleeve and a male tip with external thread.

Coupling (screwing) and uncoupling (unscrewing) of the two halves is safe and very easy. After the connection is complete, all internal components have minimal play or clearance, which significantly reduces the risk of material fatigue.

Another advantage is that the risk of permanent indentation, so-called "brinelling", on the surface of the male tip is eliminated, which can occur with push-to-connect couplings in similar extreme applications.

Series HT are used on Hydraulic tippers, commercial vehicle trailers, agricultural and construction equipment and available in nominal sizes 19, 25 (3/4" - 1").

Features

- Poppet Valve
- Coupling made from carbon steel with Zinc/Nickel surface coating
- Heavy duty internal components
- Connect under residual pressure

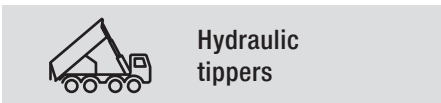
Applications

Top Features

HT

Series HT • Carbon Steel

Material	Carbon Steel
Surface Finishing	Zinc-Nickel
Standard Seal Material(s)	NBR (Buna-N®) ²
Working Temperature	-25° C ... +100° C / -13° F ... +212° F
Valve Design	Poppet Valve
Connection	Screw
Disconnection	Screw
Connect Under Pressure	not allowed
Application	Industrial Hydraulic
ISO Interchange	-



Male Tip Female Body

² Alternative seal materials are available on request.

Technical Data

Series	BG	DN Zoll Inch	DN metric ISO 4397	Q _{max}		Working Pressure		Bursting Pressure Connected		Female Body		Male Tip		Spillage	
				l/min	US GPM	bar	PSI	bar	PSI	bar	PSI	bar	PSI	ml	fl oz
HT-19	4	3/4"	19 (20)	159	42.00	350	5076	1300	18855	1000	14504	1000	14504	10	.3381
HT-25	6	1"	25	283,5	74.89	300	4351	1000	14504	1000	14504	1000	14504	15	.5072

The indicated pressure ratings only apply to the coupling itself and depend on the connection type.

Flow Characteristics

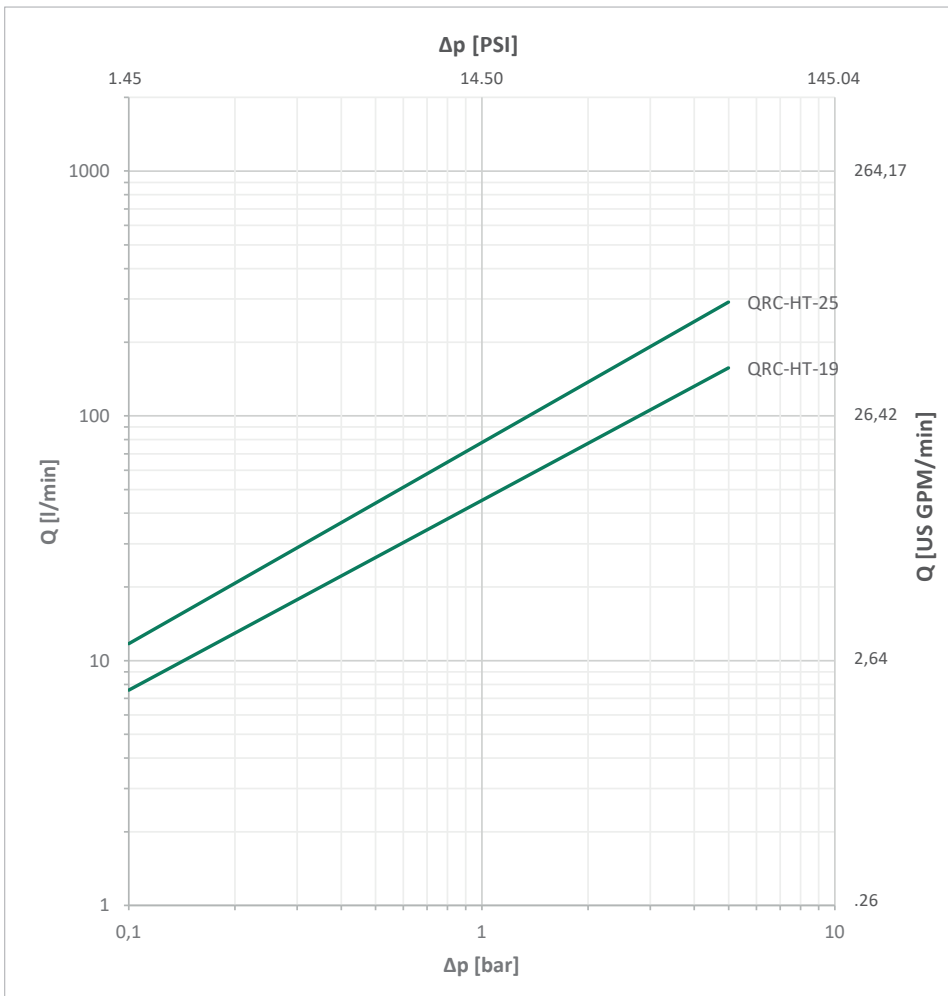

Please note: Unless otherwise stated, all flow characteristics have been determined with hydraulic oil with a kinematic viscosity of 28,8 - 35,2 mm²/s (28,8 - 35,2 cSt) and are only valid for components with non-reducing connections.

HT



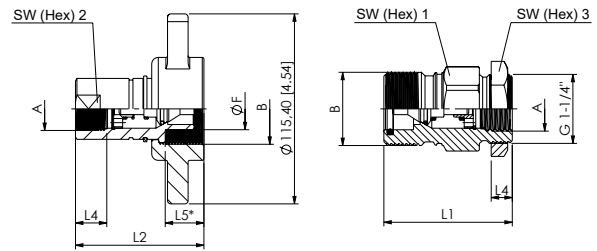

SW: Width across flats. All dimensions in mm (inch). Drawing similar Series HT-25.
* Insertion Male Tip.

Series HT-19 • BG 4 • Nominal Size 19

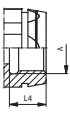
Port A	Dimensions (mm/in)											Female Body	Weight (kg/lbs) ca. per 100	Male Tip	Weight (kg/lbs) ca. per 100
	ØB	ØF	L1	L2	L4 min	L5	SW1	SW2	SW3	Ordering Codes	Ordering Codes				
Female Thread according to DIN 3852 - ISO 1179-1															
	G 3/4"	1 3/4" - 12 UN	25,3	78	78	16	23,5	46	33	50	QRC-HT-19-F-G12-B-W3	85,05 187.50	QRC-HT-19-M-G12-B-W3	74,61 164.49	
			1.00	3.07	3.07	.63	.93	1.81	1.30	1.97					

Series HT-25 • BG 6 • Nominal Size 25

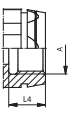
Port A	Dimensions (mm/in)											Female Body	Weight (kg/lbs) ca. per 100	Male Tip	Weight (kg/lbs) ca. per 100
	ØB	ØF	L1	L2	L4 min	L5	SW1	SW2	SW3	Ordering Codes	Ordering Codes				
Female Thread according to DIN 3852 - ISO 1179-1															
	G 1"	UNS 2 1/8"	31,7	83	83	24	21	55	40	50	QRC-HT-25-F-G16-B-W3	90,88 200.36	QRC-HT-25-M-G16-B-W3	94,79 208.98	
			1.25	3.27	3.27	.94	.83	2.17	1.57	1.97					

Series HT • Dust Protection

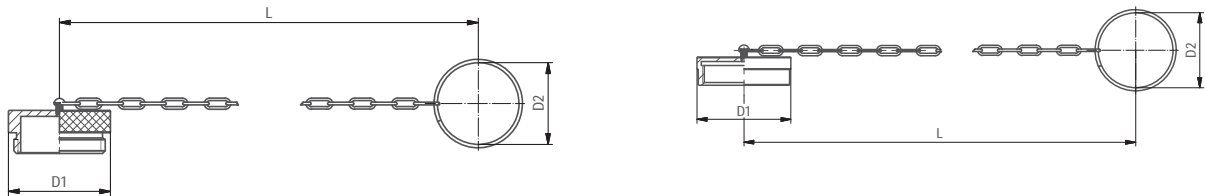

Dimensions (mm/in)			Material	Dust Plug for Female Body
D1	D2	L		Ordering Codes
48,2	45	205	Carbon Steel with Steel cable	QRC-HT-19-DF-41/CN-W3
1.90	1.95	8.07		
59,5	54	205	Carbon Steel with Steel cable	QRC-HT-25-DF-49/CN-W3
2.34	2.13	8.07		

Dimensions (mm/in)			Material	Dust Cap for Male Tip
D1	D2	L		Ordering Codes
49,5	45	205	Carbon Steel with Steel cable	QRC-HT-19-DM-41/CN-W3
1.95	1.95	8.07		
59,5	54	205	Carbon Steel with Steel cable	QRC-HT-25-DM-49/CN-W3
2.34	2.13	8.07		

Note: The connection of the two halves of a coupling is achieved depending on the type. It is important to observe the positive engagement of plug-type couplings and the secure tightening of screw-type couplings to the limit stop of the thread. Forced or improper separation will result in malfunction of the coupling.



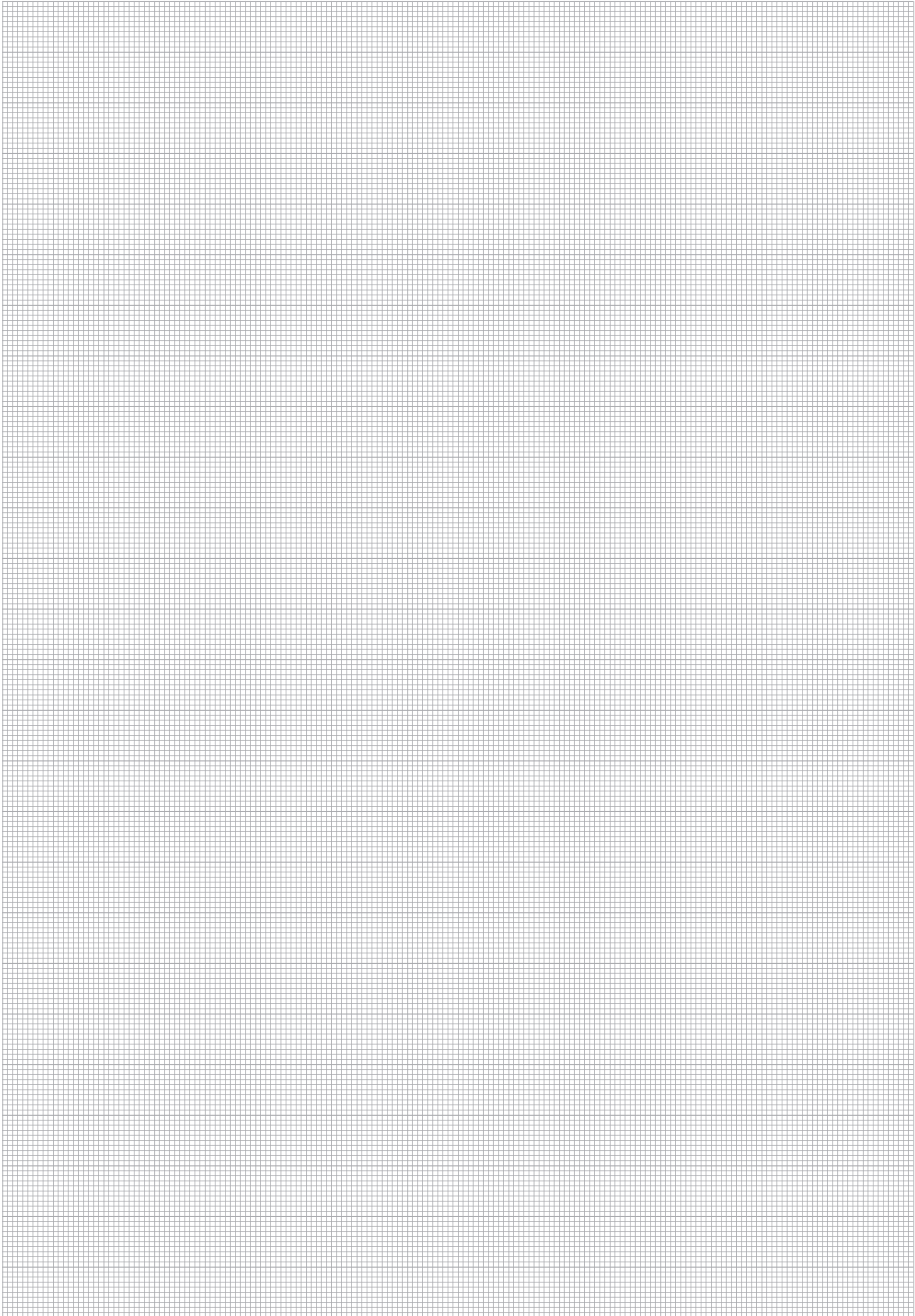

HT



Series HM • Carbon Steel and Brass
Product Description

Screw-to-connect couplings of the HM Series from STAUFF consist of a female body with a winged screw sleeve and a male tip with external thread.

Coupling (screwing) and uncoupling (unscrewing) of the two halves is safe and very easy. After the connection is complete, all internal components have minimal play or clearance, which significantly reduces the risk of material fatigue.

Another advantage is that the risk of permanent indentation, so-called "brinelling", on the surface of the male tip is eliminated, which can occur with push-to-connect couplings in similar extreme applications.

Series HM are used on hydraulic tippers and available in nominal sizes 19, 25, 31, 38 (3/4" - 1 1/2").

Features

- Flat Valve
- Coupling made from brass and carbon steel
- Heavy duty internal components
- blowout proof seals

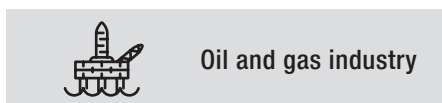
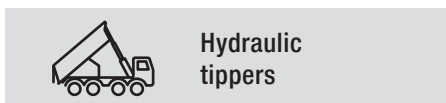
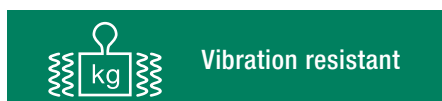
Applications

Top Features

HM

Series HM - Carbon Steel and Brass

Material	Brass and Carbon Steel
Surface Finishing	Carbon Steel: Zinc-Plating and Thick-Film-Passivation (Chrome III)
Standard Seal Material(s)	NBR (Buna-N®) ²
Working Temperature	-25° C ... +100° C / -13° F ... +212° F
Valve Design	Flat Valve
Connection	Screw
Disconnection	Screw
Connect Under Pressure	not allowed
Application	Industrial Hydraulic
ISO Interchange	-



Male Tip

Female Body

² Alternative seal materials are available on request.

Technical Data

Series	BG	DN Zoll	DN metric ISO 4397	Q _{max}		Working Pressure		Bursting Pressure Connected		Female Body		Male Tip		Spillage	
				l/min	US GPM	bar	PSI	bar	PSI	bar	PSI	bar	PSI	ml	fl oz
HM-19	4	3/4"	19 (20)	220	58.12	210	3046	1160	16824	460	6672	580	8412	0,15	.0051
HM-25	6	1"	25	260	68.68	210	3046	880	12763	370	5366	720	10443	0,4	.0135
HM-31	8	1 1/4"	31	400	105.67	190	2756	520	7542	430	6237	570	8267	0,65	.0220
HM-38	10	1 1/2"	38	600	158.50	170	2466	500	7252	430	6237	350	5076	0,85	.0287

The indicated pressure ratings only apply to the coupling itself and depend on the connection type.

Flow Characteristics

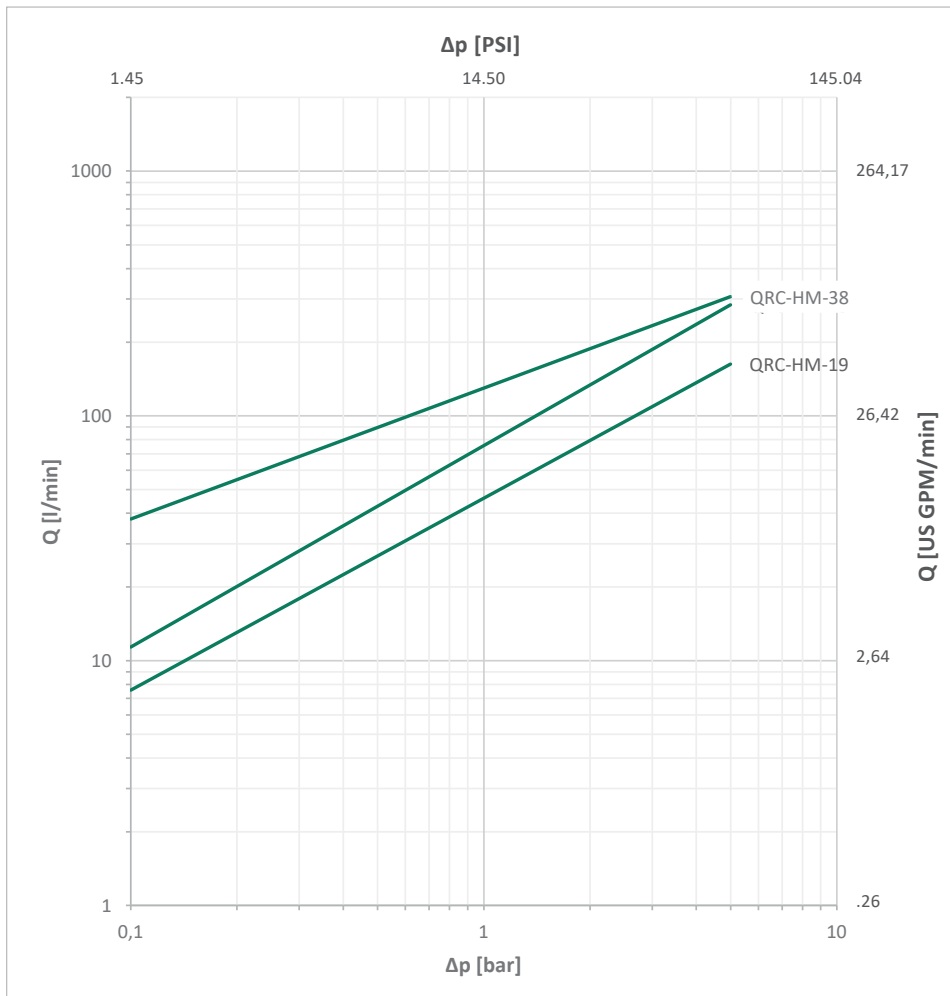

Please note: Unless otherwise stated, all flow characteristics have been determined with hydraulic oil with a kinematic viscosity of 28,8 - 35,2 mm²/s (28,8 - 35,2 cSt) and are only valid for components with non-reducing connections.

HM



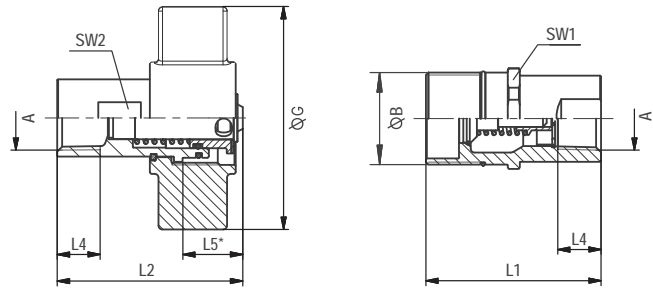

SW: Width across flats. All dimensions in mm (inch). Drawing similar Series HM-25.
* Insertion Male Tip.

Series HM-19 • BG 4 • Nominal Size 19

Port A	Dimensions (^{mm/in})								Female Body Ordering Codes	Weight (^{kg/lbs}) ca. per 100	Male Tip Ordering Codes	Weight (^{kg/lbs}) ca. per 100
	ØB	ØG	L1	L2	L4 min	L5	SW1	SW2				
Female Thread according to ANSI B 1.20.3												
	NPTF 1/2" -14	1"1/2 - 12UNF	106 4.17	79 3.11	78 3.07		41 1"5/8	29 1"1/8	QRC-HM-19-F-NF08-BT-W162	63,50 139,99	QRC-HM-19-M-NF08-B-W162	43 94,80
	NPTF 3/4" -14	1"1/2 - 12UNF	106 4.17	79 3.11	78 3.07		41 1"5/8	29 1"1/8	QRC-HM-19-F-NF12-BT-W162	60,20 132,72	QRC-HM-19-M-NF12-B-W162	39,50 87,08

Series HM-25 • BG 6 • Nominal Size 25

Port A	Dimensions (^{mm/in})								Female Body Ordering Codes	Weight (^{kg/lbs}) ca. per 100	Male Tip Ordering Codes	Weight (^{kg/lbs}) ca. per 100
	ØB	ØG	L1	L2	L4 min	L5	SW1	SW2				
Female Thread according to ANSI B 1.20.3												
	NPTF 1" -11 1/2	1"7/8 - 12UN	109,7 4,32	90 3,54	98,7 3,89		47,5 1"7/8	36 1"7/16	QRC-HM-25-F-NF16-BT-W162	104 229,28	QRC-HM-25-M-NF16-B-W162	63,30 139,55

Series HM-31 • BG 8 • Nominal Size 31,5

Port A	Dimensions (^{mm/in})								Female Body Ordering Codes	Weight (^{kg/lbs}) ca. per 100	Male Tip Ordering Codes	Weight (^{kg/lbs}) ca. per 100
	ØB	ØG	L1	L2	L4 min	L5	SW1	SW2				
Female Thread according to ANSI B 1.20.3												
	NPTF 1 1/4" -11 1/2	2"1/8 - 12UN	131,7 5,19	92,7 3,65	104,5 4,11		54 2"3/18	45 1"3/4	QRC-HM-31-F-NF20-BT-W162	125,50 276,68	QRC-HM-31-M-NF20-B-W162	76,50 168,65

Series HM-38 • BG 10 • Nominal Size 38

Port A	Dimensions (^{mm/in})								Female Body Ordering Codes	Weight (^{kg/lbs}) ca. per 100	Male Tip Ordering Codes	Weight (^{kg/lbs}) ca. per 100
	ØB	ØG	L1	L2	L4 min	L5	SW1	SW2				
Female Thread according to ANSI B 1.20.3												
	NPTF 1 1/2" -11 1/2	2"1/2 - 12UN	136 5,35	95 3,74	92,7 3,65		63,5 2"1/2	53,5 2"	QRC-HM-38-F-NF24-BT-W162	155 341,72	QRC-HM-38-M-NF24-B-W162	116 255,74

HM

Note: The connection of the two halves of a coupling is achieved depending on the type. It is important to observe the positive engagement of plug-type couplings and the secure tightening of screw-type couplings to the limit stop of the thread. Forced or improper separation will result in malfunction of the coupling.



Series HM • Dust Protection

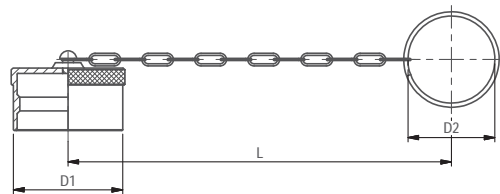
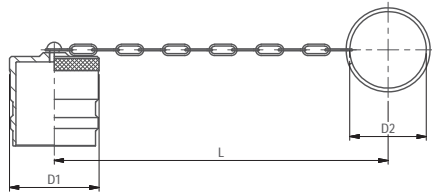

Dimensions (mm/in)			Material	Dust Plug for Female Body
D1	D2	L		Ordering Codes
40	30	210	Brass with chain	QRC-HM-19-DF-30/CN-W69
1.57	1.18	8.27		
48,0	41	270	Brass with chain	QRC-HM-25-DF-41/CN-W69
1.89	1.61	10.63		
56	48	280	Brass with chain	QRC-HM-31-DF-48/CN-W69
2.20	1.89	11.02		
63	48	280	Brass with chain	QRC-HM-38-DF-48/CN-W69
2.48	1.89	11.02		

Dimensions (mm/in)			Material	Dust Cap for Male Tip
D1	D2	L		Ordering Codes
41	30	210	Brass with chain	QRC-HM-19-DM-30/CN-W69
1.61	1.18	8.27		
53	41	270	Brass with chain	QRC-HM-25-DM-41/CN-W69
2.09	1.61	10.63		
62	48	280	Brass with chain	QRC-HM-31-DM-48/CN-W69
2.44	1.89	11.02		
69	48	280	Brass with chain	QRC-HM-38-DM-48/CN-W69
2.72	1.89	11.02		

HM



Series HV • Carbon Steel
Product Description

Screw-to-connect couplings of the HV Series from STAUFF consist of a female body with a winged screw sleeve and a male tip with external thread.

Coupling (screwing) and uncoupling (unscrewing) of the two halves is safe and very easy. After the connection is complete, all internal components have minimal play or clearance, which significantly reduces the risk of material fatigue.

Another advantage is that the risk of permanent indentation, so-called "brinelling", on the surface of the male tip is eliminated, which can occur with push-to-connect couplings in similar extreme applications.

The proven design is suitable for use in oil and gas industry as well as mobile equipment and heavy duty transportation, especially where high pressures, high flow and pulse pressure are present.

The design used heavy-duty ACME thread for durable connection strength and a heavy-duty poppet valve design that prevents seal washout under operating parameters.

Series HV are used on Hydraulic tippers and available in nominal sizes 19, 25, 31, 38, 51 (3/4" - 2").

Features

- Poppet Valve
- Zinc-Plating and Thick-Film-Passivation (Chrome III)
- Can be connect under pressure up to 100 bar (1450 PSI)

Applications

Construction Machinery

Oil and gas industry
Top Features

Designed for secure connection

Vibration resistant

Connect Under pressure

HV

Series HV ▪ Carbon Steel

Material	Carbon Steel
Surface Finishing	Zinc-Plating and Thick-Film-Passivation (Chrome III)
Standard Seal Material(s)	NBR (Buna-N®) ²
Working Temperature	-25° C ... +100° C / -13° F ... +212° F
Valve Design	Poppet Valve
Connection	Screw
Disconnection	Screw
Connect Under Pressure	Male Tip and Female Body up to max. 100 bar / 1450 PSI allowed
Application	Industrial Hydraulic
ISO Interchange	-



² Alternative seal materials are available on request.

Technical Data

Series	BG	DN Zoll Inch	DN metric ISO 4397	Q _{max}		Working Pressure		Bursting Pressure Connected		Female Body		Male Tip		Spillage	
				l/min	US GPM	bar	PSI	bar	PSI	bar	PSI	bar	PSI	ml	fl oz
HV-19	4	3/4"	19 (20)	190	50.19	350	5076	1500	21756	750	10878	1400	20305	8	.2705
HV-25	6	1"	25	280	73.97	350	5076	1600	23206	900	13053	1500	21756	16	.5410
HV-31	8	1 1/4"	31	480	126.80	350	5076	1300	18855	850	12328	1600	23206	31	10.482
HV-38	10	1 1/2"	38	700	184.92	350	5076	1200	17405	600	8702	900	13053	64	21.641
HV-51	12	2"	51	1000	264.17	350	5076	1100	15954	500	7252	600	8702	141	47.678

The indicated pressure ratings only apply to the coupling itself and depend on the connection type.

Flow Characteristics

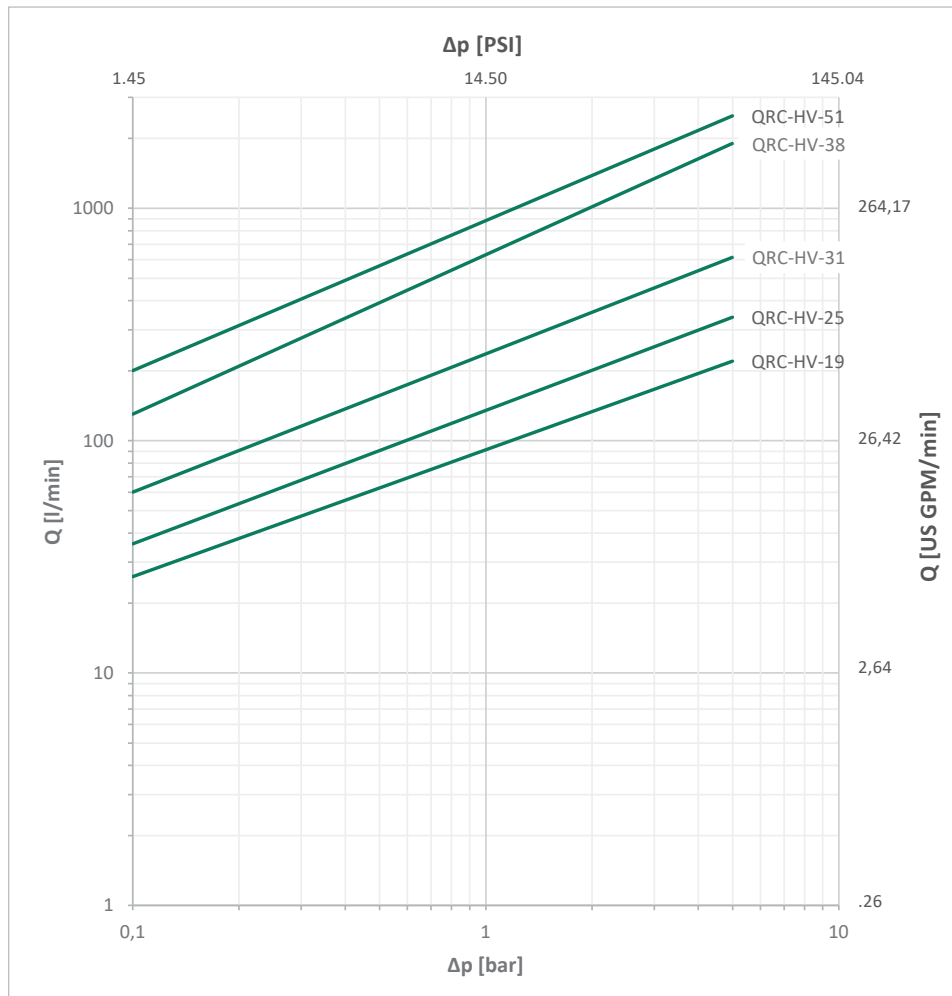

Please note: Unless otherwise stated, all flow characteristics have been determined with hydraulic oil with a kinematic viscosity of 28,8 - 35,2 mm²/s (28,8 - 35,2 cSt) and are only valid for components with non-reducing connections.

HV



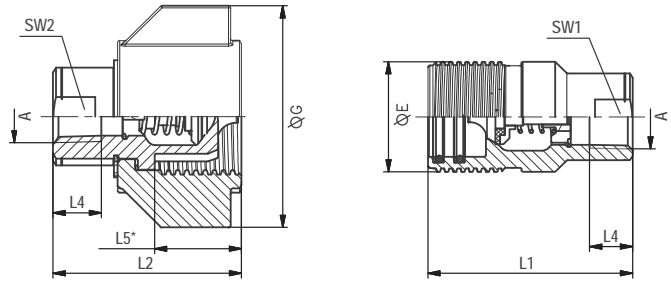

SW: Width across flats. All dimensions in mm (inch). Drawing similar Series HV-25.
* Insertion Male Tip.

Series HV-19 • BG 4 • Nominal Size 19

Port A	Dimensions (mm/in)								Female Body Ordering Codes	Weight (kg/lbs) ca. per 100	Male Tip Ordering Codes	Weight (kg/lbs) ca. per 100	
	ØE	ØG	L1	L2	L4 min	L5	SW1	SW2					
Female Thread according to ANSI B 1.20.3													
	NPTF 3/4" -14	44,5	72	83	62		22	31,8	31,8	QRC-HV-19-F-NF12-BT-W66	84	QRC-HV-19-M-NF12-B-W66	48
		1.75	2.83	3.27	2.44		0.87	1"1/4	1"1/4		185.19		105.82

Series HV-25 • BG 6 • Nominal Size 25

Port A	Dimensions (mm/in)								Female Body Ordering Codes	Weight (kg/lbs) ca. per 100	Male Tip Ordering Codes	Weight (kg/lbs) ca. per 100	
	ØE	ØG	L1	L2	L4 min	L5	SW1	SW2					
Female Thread according to ANSI B 1.20.3													
	NPTF 1" -11 1/2	57	102	106	87,6		39,95	41,3	41,3	QRC-HV-25-F-NF16-BT-W66	114,50	QRC-HV-25-M-NF16-B-W66	110
		2.25	4.01	4.17	3.45		1.57	1"5/8	1"5/8		252.43		242.51

Series HV-31 • BG 8 • Nominal Size 31,5

Port A	Dimensions (mm/in)								Female Body Ordering Codes	Weight (kg/lbs) ca. per 100	Male Tip Ordering Codes	Weight (kg/lbs) ca. per 100	
	ØE	ØG	L1	L2	L4 min	L5	SW1	SW2					
Female Thread according to ANSI B 1.20.3													
	NPTF 1 1/4" -11 1/2	66,5		136	113		51			QRC-HV-31-F-NF20-BT-W66	253	QRC-HV-31-M-NF20-B-W66	187
		2.62		5.35	4.45		12.01				557.77		412.26

Series HV-38 • BG 10 • Nominal Size 38

Port A	Dimensions (mm/in)								Female Body Ordering Codes	Weight (kg/lbs) ca. per 100	Male Tip Ordering Codes	Weight (kg/lbs) ca. per 100	
	ØE	ØG	L1	L2	L4 min	L5	SW1	SW2					
Female Thread according to ANSI B 1.20.3													
	NPTF 1 1/2" -11 1/2	82,5	140	152	133,3		64,3			QRC-HV-38-F-NF24-BT-W66	401	QRC-HV-38-M-NF24-B-W66	310
		3.25	5.51	5.98	5.25		2.53				884.05		683.43

HV

Note: The connection of the two halves of a coupling is achieved depending on the type. It is important to observe the positive engagement of plug-type couplings and the secure tightening of screw-type couplings to the limit stop of the thread. Forced or improper separation will result in malfunction of the coupling.



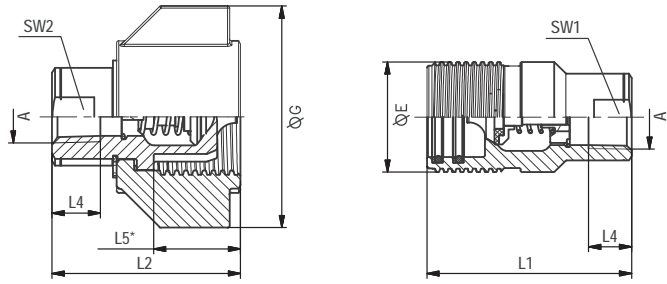

SW: Width across flats. All dimensions in mm (inch). Drawing similar Series HV-25.
* Insertion Male Tip.

Series HV-51 • BG 12 • Nominal Size 51

Port A	Dimensions (mm/in)							Female Body		Weight (^{kg} /lbs) ca. per 100	Male Tip		Weight (^{kg} /lbs) ca. per 100
	ØE	ØG	L1	L2	L4 min	L5	SW1	SW2	Ordering Codes		Ordering Codes		
Female Thread according to ANSI B 1.20.3													
	NPTF 2" -11 1/2	101	162	179	151,5		75,5		QRC-HV-51-F-NF32-BT-W66	793,50	QRC-HV-51-M-NF32-B-W66	557	
		3.97	6.37	7.05	5.96		2.97			1749.67		1227.98	

Series HV • Dust Protection



Dimensions (mm/in)			Material	Dust Plug for Female Body
D1	D2	L		Ordering Codes
			Aluminium with chain	QRC-HV-19-DF-CN-W89-SI*
69,5	48	270	Aluminium with chain	QRC-HV-25-DF-48/CN-W89-SI
2.74	1.89	10.63	Aluminium with chain	QRC-HV-31-DF-49/CN-W89-SI
75,5	49	270	Aluminium with chain	QRC-HV-38-DF-48/CN-W89-SI
2.97	1.93	10.63	Aluminium with chain	QRC-HV-51-DF-CN-W89-SI*
95,5	48	280	Aluminium with chain	
3.76	1.89	11.02	Aluminium with chain	
113,5	85	450	Aluminium with chain	
4.47	3.35	17.72	Aluminium with chain	

Dimensions (mm/in)			Material	Dust Cap for Male Tip
D1	D2	L		Ordering Codes
			Aluminium with chain	QRC-HV-19-DM-CN-W89-SI*
70	48	270	Aluminium with chain	QRC-HV-25-DM-48/CN-W89-SI
2.76	1.89	10.63	Aluminium with chain	QRC-HV-31-DM-49/CN-W89-SI
80,5	49	270	Aluminium with chain	QRC-HV-38-DM-48/CN-W89-SI
3.17	1.93	10.63	Aluminium with chain	QRC-HV-51-DM-CN-W89-SI*
96	48	280	Aluminium with chain	
3.78	1.89	11.02	Aluminium with chain	

* Available on request.



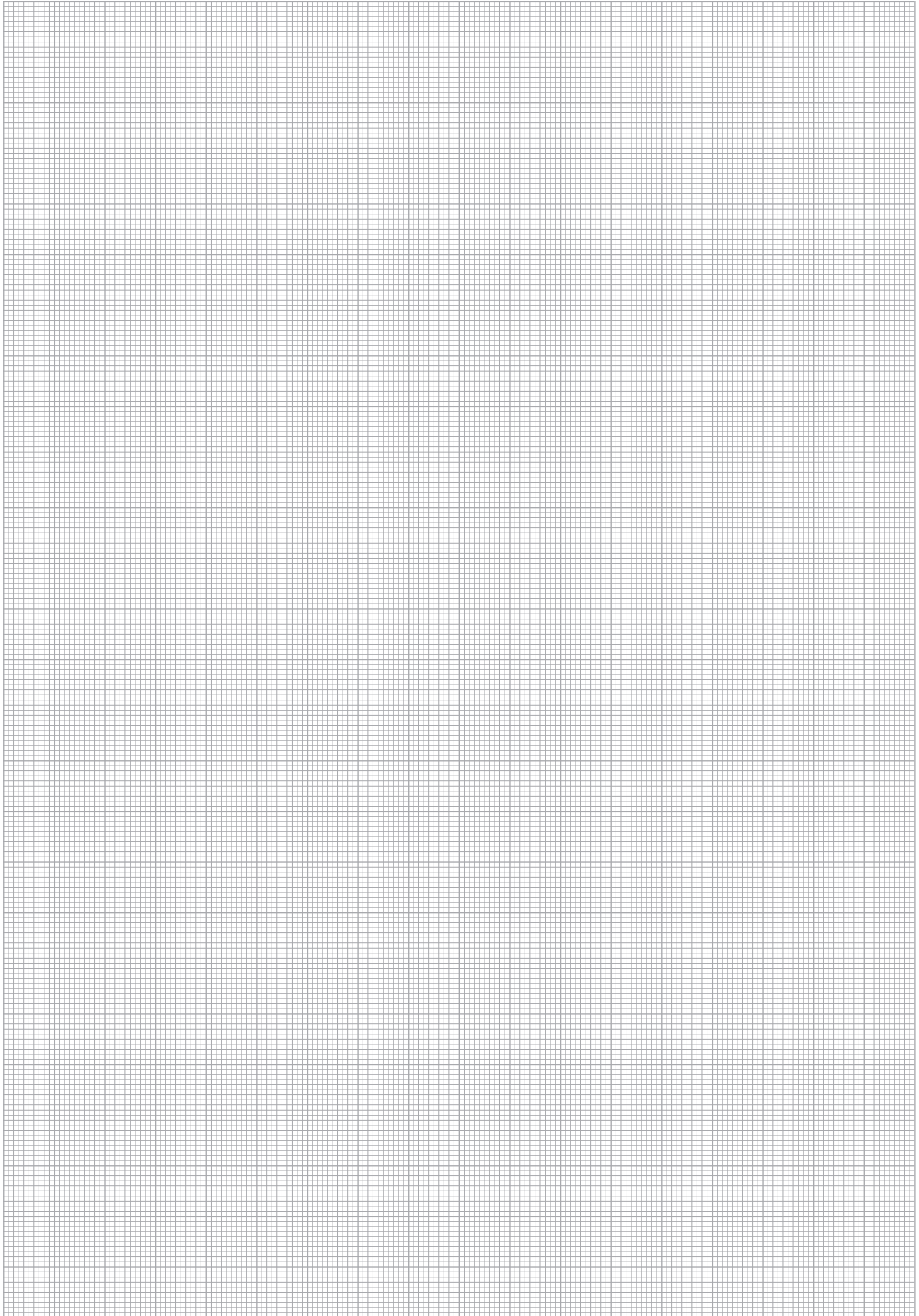

HV





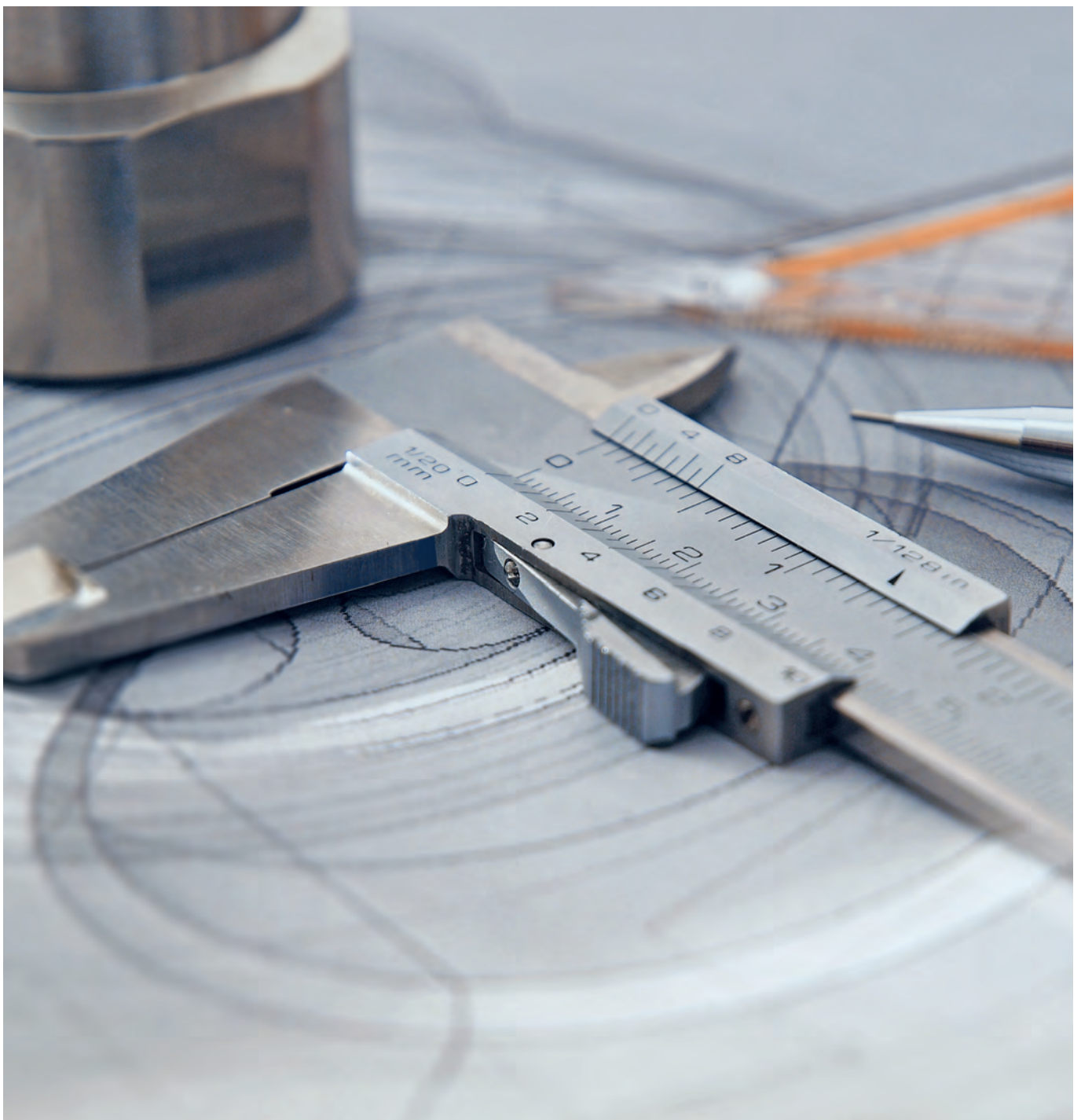

In addition of our common couplings Series, we also have various special designs for a huge range of special applications, even outside the hydraulic area, in our portfolio.

We are open minded to find customized solutions for all kind of applications and different influencing factors and work them out for or together with our customers.

Water Application



Electro-technics

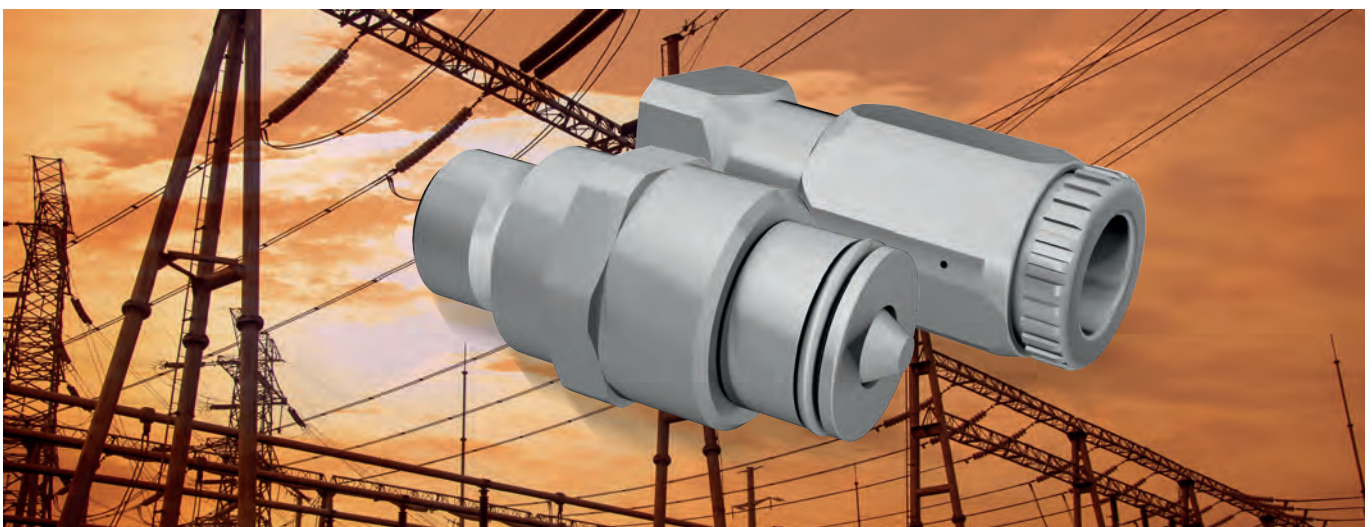

Note: The connection of the two halves of a coupling is achieved depending on the type. It is important to observe the positive engagement of plug-type couplings and the secure tightening of screw-type couplings to the limit stop of the thread. Forced or improper separation will result in malfunction of the coupling.



Automotive Engineering



Agricultural Engineering



Refrigeration



Note: The connection of the two halves of a coupling is achieved depending on the type. It is important to observe the positive engagement of plug-type couplings and the secure tightening of screw-type couplings to the limit stop of the thread. Forced or improper separation will result in malfunction of the coupling.





Colour Marking Rings		192 - 217	Dust cover clips	218
Introduction Colour Marking Rings		192 - 193	Dust cover body	218
Colour Marking Rings for Push-to-Connect Couplings (one-tone / two-tone)	Series QRC-FF ▪ Flat Face Coupling acc. to ISO 16028	194 - 197	Marking Clips	219
	FC Series ▪ Flat Face Coupling acc. to ISO 16028, Connect Under Pressure	198 - 199	Safety Clamp with 4-hole flange	219
	Series QRC-HP ▪ ISO 7241-1, Series A, Push-Pull	200 - 203	Anchor bracket for Male Tip	219
Colour Marking Rings for Screw-to-Connect Couplings (one-tone / two-tone)	Series QRC-HS ▪ ISO 14541	204 - 207	Seal Kits	220 - 221
	Series QRC-HS-HX ▪ ISO 14541 (Version with Hexagonal Sleeve)	208 - 209		
	Series QRC-RH ▪ Flat Face Coupling, Pipeline Coupling	210 - 213		
	FG Series ▪ Flat Face Coupling, Connect Under Pressure	214 - 217		



Colour Marking Rings for STAUFF Quick Release Couplings Introduction

If multiple identical or similar quick release couplings are used in a vehicle, machine or system, there is a risk of confusion when connecting coupling elements.

The option of using colour marking rings for STAUFF Quick Release Couplings allows the quick and correct matching of lines.

Initially, STAUFF offers the colour marking rings for the following Series:

- **QRC-FF** (flat-face push-to-connect couplings)
- **QRC-FC** (flat-face push-to-connect couplings)
- **QRC-HP** (push-to-connect couplings with poppet valve)
- **QRC-HS** (screw-to-connect couplings with poppet valve)
- **QRC-RH** (flat-face pipeline couplings)
- **QRC-FG** (flat-face screw-to-connect couplings)

Successive introduction of colour marking rings for additional Series is planned for the future.

How exactly has STAUFF implemented the colour marking ring option for quick release couplings?

As a standard, all male tips and female bodies from the Series listed above are supplied with grooves in easily visible locations on external parts. The customer/user can insert rings into these grooves for colour marking the couplings.

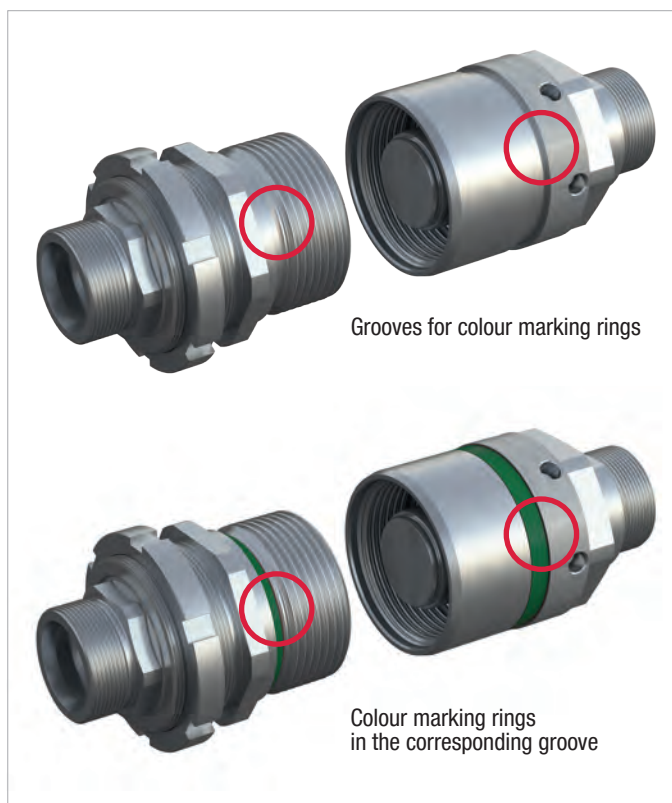

Which material is used to manufacture the rings for colour marking the couplings?

The rings are manufactured from thermoplastic polyurethane (TPU). TPU is a lightweight, elastic material with very good abrasion and wear resistance, paired with high resilience.

Do these grooves impact the performance or durability of the quick release couplings?

No, the integrity of the coupling is not affected. The grooves for the colour marking rings are placed in non-critical areas on external parts, such as the sliding sleeve.

Extensive finite-element-method (FEM) simulations during the development phase and additional burst and pressure tests at the STAUFF Technology Centre delivered the clear conclusion that the grooves have no impact on performance and that the quick release couplings continue to meet or exceed the usual high requirements.



How are the colour marking rings installed on the couplings?

The rings for colour marking the couplings can be installed by the customer/user as required.

Does STAUFF also supply couplings with pre-assembled colour marking rings?

No, this is currently not planned due to the large number of possible combinations.

Is a special tool required for installing the colour marking rings?

No special tools are required. Simple hook tools can make installation easier, though. The development focused especially on a user-friendly solution. If necessary, the rings can also be expanded manually and pushed into the corresponding position.



Colour Marking Rings for STAUFF Quick Release Couplings Introduction

Can the colour marking rings also be retrofitted on couplings that are already installed?

Yes, if the coupling has the required grooves, then the marking rings can be installed at any time.

Can the Colour marking rings be reused on other couplings?

Generally, yes. We do not recommend re-using damaged (e.g. cracked) rings, though.

What if I do not want or need any colour coding?

In that case, simply omit the colour marking rings and use the couplings without colour marking as before.

Which colours does STAUFF offer as a standard?

STAUFF offers the colour marking rings in the following standard colours:

Colour	RAL Code	Colour	RAL Code
	RAL 3000		RAL 6002
	RAL 9005		RAL 2011
	RAL 1018		RAL 4001
	RAL 5005		RAL 7000

Small colour deviations may be caused by the production process.

Are other colours also possible?

Other colours can also be supplied, depending on the required quantities. Please contact a STAUFF sales representative for an individual offer.

Can rings for colour marking also be fitted when using dust covers ?

No, when using a dust cover for female bodies, the colour marking must be done via the marking clips. The male tip must be fitted with a colour marking ring.



Is two-tone colour marking also possible?

Yes, this is also possible. Half-width rings can be used to create a large number of different colour combinations. Accordingly, two rings are required.

Please contact STAUFF for an individual offer.

Why can it be useful to use a two-tone colour marking?

It may happen that one connection is used for several lines. In this way, the dual function of the connection can be colour-coded and it becomes clear to the user that he can theoretically connect both lines.

What do I need to know about storing the rings?

The rings are subject to the same requirements as many other plastic and elastomer products.

With correct storage, the colour marking rings can be stored for up to 10 years. Correct storage means that the rings are not continuously exposed to external environmental influences.

The rings should be stored in a dry, draught-free location at constant temperatures below +25 °C and protected against ozone and strong artificial light. Failure to comply with these recommendations can cause the rings to become brittle.

Are there any restrictions with regard to media resistance?

No. Selecting the right material was one of the crucial criteria for the development of the colour marking rings.

Resistance to all media generally used in hydraulic systems was therefore of great importance. In addition to this, the ring material is also resistant to other oils, greases and a number of common solvents.

If you are unsure about the resistance of the rings to specific media or if you have any questions, please contact STAUFF for more information.



How do the rings react to extreme sunlight?

The thermoplastic polyurethane (TPU) used is thermally stable and also features excellent UV resistance.



Colour Marking Rings for Female Bodies Series QRC-FF-F

QRC-FF-06-F



Colour	Ordering Codes
	MR-QRC-24.1x1.2x3.6-K-RD
	MR-QRC-24.1x1.2x3.6-K-BK
	MR-QRC-24.1x1.2x3.6-K-YE
	MR-QRC-24.1x1.2x3.6-K-BU
	MR-QRC-24.1x1.2x3.6-K-GN
	MR-QRC-24.1x1.2x3.6-K-OE
	MR-QRC-24.1x1.2x3.6-K-PU
	MR-QRC-24.1x1.2x3.6-K-GY

QRC-FF-10-F



Colour	Ordering Codes
	MR-QRC-28x1.2x4-K-RD
	MR-QRC-28x1.2x4-K-BK
	MR-QRC-28x1.2x4-K-YE
	MR-QRC-28x1.2x4-K-BU
	MR-QRC-28x1.2x4-K-GN
	MR-QRC-28x1.2x4-K-OE
	MR-QRC-28x1.2x4-K-PU
	MR-QRC-28x1.2x4-K-GY

QRC-FF-12-F



Colour	Ordering Codes
	MR-QRC-33.7x1.2x3.8-K-RD
	MR-QRC-33.7x1.2x3.8-K-BK
	MR-QRC-33.7x1.2x3.8-K-YE
	MR-QRC-33.7x1.2x3.8-K-BU
	MR-QRC-33.7x1.2x3.8-K-GN
	MR-QRC-33.7x1.2x3.8-K-OE
	MR-QRC-33.7x1.2x3.8-K-PU
	MR-QRC-33.7x1.2x3.8-K-GY

QRC-FF-16-F



Colour	Ordering Codes
	MR-QRC-37.9x1.4x4-K-RD
	MR-QRC-37.9x1.4x4-K-BK
	MR-QRC-37.9x1.4x4-K-YE
	MR-QRC-37.9x1.4x4-K-BU
	MR-QRC-37.9x1.4x4-K-GN
	MR-QRC-37.9x1.4x4-K-OE
	MR-QRC-37.9x1.4x4-K-PU
	MR-QRC-37.9x1.4x4-K-GY

QRC-FF-19-F



Colour	Ordering Codes
	MR-QRC-41.1x1.4x4-K-RD
	MR-QRC-41.1x1.4x4-K-BK
	MR-QRC-41.1x1.4x4-K-YE
	MR-QRC-41.1x1.4x4-K-BU
	MR-QRC-41.1x1.4x4-K-GN
	MR-QRC-41.1x1.4x4-K-OE
	MR-QRC-41.1x1.4x4-K-PU
	MR-QRC-41.1x1.4x4-K-GY

QRC-FF-25-F



Colour	Ordering Codes
	MR-QRC-49.4x1.4x5-K-RD
	MR-QRC-49.4x1.4x5-K-BK
	MR-QRC-49.4x1.4x5-K-YE
	MR-QRC-49.4x1.4x5-K-BU
	MR-QRC-49.4x1.4x5-K-GN
	MR-QRC-49.4x1.4x5-K-OE
	MR-QRC-49.4x1.4x5-K-PU
	MR-QRC-49.4x1.4x5-K-GY

QRC-FF-38-F



Colour	Ordering Codes
	MR-QRC-75.2x1.4x7.5-K-RD
	MR-QRC-75.2x1.4x7.5-K-BK
	MR-QRC-75.2x1.4x7.5-K-YE
	MR-QRC-75.2x1.4x7.5-K-BU
	MR-QRC-75.2x1.4x7.5-K-GN
	MR-QRC-75.2x1.4x7.5-K-OE
	MR-QRC-75.2x1.4x7.5-K-PU
	MR-QRC-75.2x1.4x7.5-K-GY

When using a dust cover for female Bodies, the colour marking must be done via the marking clips.

Note: The matching of the colour marking rings applies to all connection types of the couplings in the respective nominal sizes.



On request: Two-Tone Colour Marking Rings for Female Bodies
 Series QRC-FF-F

QRC-FF-10-F



Colour	Ordering Codes
	MR-QRC-28x1.2x2-K-RD
	MR-QRC-28x1.2x2-K-BK
	MR-QRC-28x1.2x2-K-YE
	MR-QRC-28x1.2x2-K-BU
	MR-QRC-28x1.2x2-K-GN
	MR-QRC-28x1.2x2-K-OE
	MR-QRC-28x1.2x2-K-PU
	MR-QRC-28x1.2x2-K-GY

QRC-FF-12-F



Colour	Ordering Codes
	MR-QRC-33.7x1.2x1.9-K-RD
	MR-QRC-33.7x1.2x1.9-K-BK
	MR-QRC-33.7x1.2x1.9-K-YE
	MR-QRC-33.7x1.2x1.9-K-BU
	MR-QRC-33.7x1.2x1.9-K-GN
	MR-QRC-33.7x1.2x1.9-K-OE
	MR-QRC-33.7x1.2x1.9-K-PU
	MR-QRC-33.7x1.2x1.9-K-GY

QRC-FF-16-F



Colour	Ordering Codes
	MR-QRC-37.9x1.4x2-K-RD
	MR-QRC-37.9x1.4x2-K-BK
	MR-QRC-37.9x1.4x2-K-YE
	MR-QRC-37.9x1.4x2-K-BU
	MR-QRC-37.9x1.4x2-K-GN
	MR-QRC-37.9x1.4x2-K-OE
	MR-QRC-37.9x1.4x2-K-PU
	MR-QRC-37.9x1.4x2-K-GY

QRC-FF-19-F



Colour	Ordering Codes
	MR-QRC-41.1x1.4x2-K-RD
	MR-QRC-41.1x1.4x2-K-BK
	MR-QRC-41.1x1.4x2-K-YE
	MR-QRC-41.1x1.4x2-K-BU
	MR-QRC-41.1x1.4x2-K-GN
	MR-QRC-41.1x1.4x2-K-OE
	MR-QRC-41.1x1.4x2-K-PU
	MR-QRC-41.1x1.4x2-K-GY

QRC-FF-25-F



Colour	Ordering Codes
	MR-QRC-49.4x1.4x2.5-K-RD
	MR-QRC-49.4x1.4x2.5-K-BK
	MR-QRC-49.4x1.4x2.5-K-YE
	MR-QRC-49.4x1.4x2.5-K-BU
	MR-QRC-49.4x1.4x2.5-K-GN
	MR-QRC-49.4x1.4x2.5-K-OE
	MR-QRC-49.4x1.4x2.5-K-PU
	MR-QRC-49.4x1.4x2.5-K-GY

When using a dust cover for female Bodies, the colour marking must be done via the marking clips.

Note: Two-Tone Colour Marking Rings are available on request. Please contact STAUFF for an individual offer.



Colour Marking Rings for Male Tips
Series QRC-FF-M

QRC-FF-06-M



Colour	Ordering Codes
	MR-QRC-18.3x1.2x2-K-RD
	MR-QRC-18.3x1.2x2-K-BK
	MR-QRC-18.3x1.2x2-K-YE
	MR-QRC-18.3x1.2x2-K-BU
	MR-QRC-18.3x1.2x2-K-GN
	MR-QRC-18.3x1.2x2-K-OE
	MR-QRC-18.3x1.2x2-K-PU
	MR-QRC-18.3x1.2x2-K-GY

QRC-FF-10-M



Colour	Ordering Codes
	MR-QRC-20.1x1.2x2-K-RD
	MR-QRC-20.1x1.2x2-K-BK
	MR-QRC-20.1x1.2x2-K-YE
	MR-QRC-20.1x1.2x2-K-BU
	MR-QRC-20.1x1.2x2-K-GN
	MR-QRC-20.1x1.2x2-K-OE
	MR-QRC-20.1x1.2x2-K-PU
	MR-QRC-20.1x1.2x2-K-GY

QRC-FF-12-M



Colour	Ordering Codes
	MR-QRC-28x1.2x4-K-RD
	MR-QRC-28x1.2x4-K-BK
	MR-QRC-28x1.2x4-K-YE
	MR-QRC-28x1.2x4-K-BU
	MR-QRC-28x1.2x4-K-GN
	MR-QRC-28x1.2x4-K-OE
	MR-QRC-28x1.2x4-K-PU
	MR-QRC-28x1.2x4-K-GY

QRC-FF-16-M



Colour	Ordering Codes
	MR-QRC-32.1x1.2x4-K-RD
	MR-QRC-32.1x1.2x4-K-BK
	MR-QRC-32.1x1.2x4-K-YE
	MR-QRC-32.1x1.2x4-K-BU
	MR-QRC-32.1x1.2x4-K-GN
	MR-QRC-32.1x1.2x4-K-OE
	MR-QRC-32.1x1.2x4-K-PU
	MR-QRC-32.1x1.2x4-K-GY

QRC-FF-19-M



Colour	Ordering Codes
	MR-QRC-37.9x1.4x4-K-RD
	MR-QRC-37.9x1.4x4-K-BK
	MR-QRC-37.9x1.4x4-K-YE
	MR-QRC-37.9x1.4x4-K-BU
	MR-QRC-37.9x1.4x4-K-GN
	MR-QRC-37.9x1.4x4-K-OE
	MR-QRC-37.9x1.4x4-K-PU
	MR-QRC-37.9x1.4x4-K-GY

QRC-FF-25-M



Colour	Ordering Codes
	MR-QRC-49.4x1.4x5-K-RD
	MR-QRC-49.4x1.4x5-K-BK
	MR-QRC-49.4x1.4x5-K-YE
	MR-QRC-49.4x1.4x5-K-BU
	MR-QRC-49.4x1.4x5-K-GN
	MR-QRC-49.4x1.4x5-K-OE
	MR-QRC-49.4x1.4x5-K-PU
	MR-QRC-49.4x1.4x5-K-GY

QRC-FF-38-M



Colour	Ordering Codes
	MR-QRC-65x1.4x6-K-RD
	MR-QRC-65x1.4x6-K-BK
	MR-QRC-65x1.4x6-K-YE
	MR-QRC-65x1.4x6-K-BU
	MR-QRC-65x1.4x6-K-GN
	MR-QRC-65x1.4x6-K-OE
	MR-QRC-65x1.4x6-K-PU
	MR-QRC-65x1.4x6-K-GY

Note: The matching of the colour marking rings applies to all connection types of the couplings in the respective nominal sizes.



On request: Two-Tone Colour Marking Rings for Male Tips
 Series QRC-FF-M

QRC-FF-10-M



Colour	Ordering Codes
	MR-QRC-20.1x1.2x1-K-RD
	MR-QRC-20.1x1.2x1-K-BK
	MR-QRC-20.1x1.2x1-K-YE
	MR-QRC-20.1x1.2x1-K-BU
	MR-QRC-20.1x1.2x1-K-GN
	MR-QRC-20.1x1.2x1-K-OE
	MR-QRC-20.1x1.2x1-K-PU
	MR-QRC-20.1x1.2x1-K-GY

QRC-FF-12-M



Colour	Ordering Codes
	MR-QRC-28x1.2x2-K-RD
	MR-QRC-28x1.2x2-K-BK
	MR-QRC-28x1.2x2-K-YE
	MR-QRC-28x1.2x2-K-BU
	MR-QRC-28x1.2x2-K-GN
	MR-QRC-28x1.2x2-K-OE
	MR-QRC-28x1.2x2-K-PU
	MR-QRC-28x1.2x2-K-GY

QRC-FF-16-M



Colour	Ordering Codes
	MR-QRC-32.1x1.2x2-K-RD
	MR-QRC-32.1x1.2x2-K-BK
	MR-QRC-32.1x1.2x2-K-YE
	MR-QRC-32.1x1.2x2-K-BU
	MR-QRC-32.1x1.2x2-K-GN
	MR-QRC-32.1x1.2x2-K-OE
	MR-QRC-32.1x1.2x2-K-PU
	MR-QRC-32.1x1.2x2-K-GY

QRC-FF-19-M



Colour	Ordering Codes
	MR-QRC-37.9x1.4x2-K-RD
	MR-QRC-37.9x1.4x2-K-BK
	MR-QRC-37.9x1.4x2-K-YE
	MR-QRC-37.9x1.4x2-K-BU
	MR-QRC-37.9x1.4x2-K-GN
	MR-QRC-37.9x1.4x2-K-OE
	MR-QRC-37.9x1.4x2-K-PU
	MR-QRC-37.9x1.4x2-K-GY

QRC-FF-25-M



Colour	Ordering Codes
	MR-QRC-49.4x1.4x2.5-K-RD
	MR-QRC-49.4x1.4x2.5-K-BK
	MR-QRC-49.4x1.4x2.5-K-YE
	MR-QRC-49.4x1.4x2.5-K-BU
	MR-QRC-49.4x1.4x2.5-K-GN
	MR-QRC-49.4x1.4x2.5-K-OE
	MR-QRC-49.4x1.4x2.5-K-PU
	MR-QRC-49.4x1.4x2.5-K-GY

Note: Two-Tone Colour Marking Rings are available on request. Please contact STAUFF for an individual offer.



Colour Marking Rings for Male Tips
Series QRC-FC-M

QRC-FC-10-M



Colour	Ordering Codes
	MR-QRC-28x1.2x4-K-RD
	MR-QRC-28x1.2x4-K-BK
	MR-QRC-28x1.2x4-K-YE
	MR-QRC-28x1.2x4-K-BU
	MR-QRC-28x1.2x4-K-GN
	MR-QRC-28x1.2x4-K-OE
	MR-QRC-28x1.2x4-K-PU
	MR-QRC-28x1.2x4-K-GY

QRC-FC-12-M



Colour	Ordering Codes
	MR-QRC-32.1x1.2x4-K-RD
	MR-QRC-32.1x1.2x4-K-BK
	MR-QRC-32.1x1.2x4-K-YE
	MR-QRC-32.1x1.2x4-K-BU
	MR-QRC-32.1x1.2x4-K-GN
	MR-QRC-32.1x1.2x4-K-OE
	MR-QRC-32.1x1.2x4-K-PU
	MR-QRC-32.1x1.2x4-K-GY

QRC-FC-16-M



Colour	Ordering Codes
	MR-QRC-37.9x1.4x4-K-RD
	MR-QRC-37.9x1.4x4-K-BK
	MR-QRC-37.9x1.4x4-K-YE
	MR-QRC-37.9x1.4x4-K-BU
	MR-QRC-37.9x1.4x4-K-GN
	MR-QRC-37.9x1.4x4-K-OE
	MR-QRC-37.9x1.4x4-K-PU
	MR-QRC-37.9x1.4x4-K-GY

QRC-FC-19-M



Colour	Ordering Codes
	MR-QRC-41.1x1.4x4-K-RD
	MR-QRC-41.1x1.4x4-K-BK
	MR-QRC-41.1x1.4x4-K-YE
	MR-QRC-41.1x1.4x4-K-BU
	MR-QRC-41.1x1.4x4-K-GN
	MR-QRC-41.1x1.4x4-K-OE
	MR-QRC-41.1x1.4x4-K-PU
	MR-QRC-41.1x1.4x4-K-GY

QRC-FC-25-M



Colour	Ordering Codes
	MR-QRC-49.4x1.4x5-K-RD
	MR-QRC-49.4x1.4x5-K-BK
	MR-QRC-49.4x1.4x5-K-YE
	MR-QRC-49.4x1.4x5-K-BU
	MR-QRC-49.4x1.4x5-K-GN
	MR-QRC-49.4x1.4x5-K-OE
	MR-QRC-49.4x1.4x5-K-PU
	MR-QRC-49.4x1.4x5-K-GY

Note: The matching of the colour marking rings applies to all connection types of the couplings in the respective nominal sizes.



On request: Two-Tone Colour Marking Rings for Male Tips
 Series QRC-FC-M

QRC-FC-10-M

Colour	Ordering Codes
	MR-QRC-28x1.2x2-K-RD
	MR-QRC-28x1.2x2-K-BK
	MR-QRC-28x1.2x2-K-YE
	MR-QRC-28x1.2x2-K-BU
	MR-QRC-28x1.2x2-K-GN
	MR-QRC-28x1.2x2-K-OE
	MR-QRC-28x1.2x2-K-PU
	MR-QRC-28x1.2x2-K-GY

QRC-FC-12-M

Colour	Ordering Codes
	MR-QRC-32.1x1.2x2-K-RD
	MR-QRC-32.1x1.2x2-K-BK
	MR-QRC-32.1x1.2x2-K-YE
	MR-QRC-32.1x1.2x2-K-BU
	MR-QRC-32.1x1.2x2-K-GN
	MR-QRC-32.1x1.2x2-K-OE
	MR-QRC-32.1x1.2x2-K-PU
	MR-QRC-32.1x1.2x2-K-GY

QRC-FC-16-M

Colour	Ordering Codes
	MR-QRC-37.9x1.4x2-K-RD
	MR-QRC-37.9x1.4x2-K-BK
	MR-QRC-37.9x1.4x2-K-YE
	MR-QRC-37.9x1.4x2-K-BU
	MR-QRC-37.9x1.4x2-K-GN
	MR-QRC-37.9x1.4x2-K-OE
	MR-QRC-37.9x1.4x2-K-PU
	MR-QRC-37.9x1.4x2-K-GY

QRC-FC-19-M

Colour	Ordering Codes
	MR-QRC-41.1x1.4x2-K-RD
	MR-QRC-41.1x1.4x2-K-BK
	MR-QRC-41.1x1.4x2-K-YE
	MR-QRC-41.1x1.4x2-K-BU
	MR-QRC-41.1x1.4x2-K-GN
	MR-QRC-41.1x1.4x2-K-OE
	MR-QRC-41.1x1.4x2-K-PU
	MR-QRC-41.1x1.4x2-K-GY

QRC-FC-25-M

Colour	Ordering Codes
	MR-QRC-49.4x1.4x2.5-K-RD
	MR-QRC-49.4x1.4x2.5-K-BK
	MR-QRC-49.4x1.4x2.5-K-YE
	MR-QRC-49.4x1.4x2.5-K-BU
	MR-QRC-49.4x1.4x2.5-K-GN
	MR-QRC-49.4x1.4x2.5-K-OE
	MR-QRC-49.4x1.4x2.5-K-PU
	MR-QRC-49.4x1.4x2.5-K-GY

Note: Two-Tone Colour Marking Rings are available on request. Please contact STAUFF for an individual offer.



Colour Marking Rings for Female Bodies Series QRC-HP-F

QRC-HP-10-F



Colour	Ordering Codes
	MR-QRC-28x1.2x2-RD
	MR-QRC-28x1.2x2-BK
	MR-QRC-28x1.2x2-YE
	MR-QRC-28x1.2x2-BU
	MR-QRC-28x1.2x2-GN
	MR-QRC-28x1.2x2-OE
	MR-QRC-28x1.2x2-PU
	MR-QRC-28x1.2x2-GY

QRC-HP-12-F



Colour	Ordering Codes
	MR-QRC-33.7x1.2x3.8-K-RD
	MR-QRC-33.7x1.2x3.8-K-BK
	MR-QRC-33.7x1.2x3.8-K-YE
	MR-QRC-33.7x1.2x3.8-K-BU
	MR-QRC-33.7x1.2x3.8-K-GN
	MR-QRC-33.7x1.2x3.8-K-OE
	MR-QRC-33.7x1.2x3.8-K-PU
	MR-QRC-33.7x1.2x3.8-K-GY

When using a dust cover for female Bodies, the colour marking must be done via the marking clips.

QRC-HP-19-F



Colour	Ordering Codes
	MR-QRC-41.1x1.4x4-K-RD
	MR-QRC-41.1x1.4x4-K-BK
	MR-QRC-41.1x1.4x4-K-YE
	MR-QRC-41.1x1.4x4-K-BU
	MR-QRC-41.1x1.4x4-K-GN
	MR-QRC-41.1x1.4x4-K-OE
	MR-QRC-41.1x1.4x4-K-PU
	MR-QRC-41.1x1.4x4-K-GY

QRC-HP-25-F











Colour	Ordering Codes
	MR-QRC-49.4x1.4x5-RD
	MR-QRC-49.4x1.4x5-BK
	MR-QRC-49.4x1.4x5-YE
	MR-QRC-49.4x1.4x5-BU
	MR-QRC-49.4x1.4x5-GN
	MR-QRC-49.4x1.4x5-OE
	MR-QRC-49.4x1.4x5-PU
	MR-QRC-49.4x1.4x5-GY

Note: The matching of the colour marking rings applies to all connection types of the couplings in the respective nominal sizes.



**On request: Two-Tone Colour Marking Rings for Female Bodies
Series QRC-HP-F**
QRC-HP-19-F

Colour	Ordering Codes
	MR-QRC-41.1x1.4x2-K-RD
	MR-QRC-41.1x1.4x2-K-BK
	MR-QRC-41.1x1.4x2-K-YE
	MR-QRC-41.1x1.4x2-K-BU
	MR-QRC-41.1x1.4x2-K-GN
	MR-QRC-41.1x1.4x2-K-OE
	MR-QRC-41.1x1.4x2-K-PU
	MR-QRC-41.1x1.4x2-K-GY

When using a dust cover for female Bodies, the colour marking must be done via the marking clips.



Colour Marking Rings for Male Tips Series QRC-HP-M

QRC-HP-10-M



Colour	Ordering Codes
	MR-QRC-15.8x1.2x2.5-RD
	MR-QRC-15.8x1.2x2.5-BK
	MR-QRC-15.8x1.2x2.5-YE
	MR-QRC-15.8x1.2x2.5-BU
	MR-QRC-15.8x1.2x2.5-GN
	MR-QRC-15.8x1.2x2.5-OE
	MR-QRC-15.8x1.2x2.5-PU
	MR-QRC-15.8x1.2x2.5-GY

QRC-HP-12-M



Colour	Ordering Codes
	MR-QRC-20.1x1.2x2-K-RD
	MR-QRC-20.1x1.2x2-K-BK
	MR-QRC-20.1x1.2x2-K-YE
	MR-QRC-20.1x1.2x2-K-BU
	MR-QRC-20.1x1.2x2-K-GN
	MR-QRC-20.1x1.2x2-K-OE
	MR-QRC-20.1x1.2x2-K-PU
	MR-QRC-20.1x1.2x2-K-GY

QRC-HP-19-M



Colour	Ordering Codes
	MR-QRC-28x1.2x2-K-RD
	MR-QRC-28x1.2x2-K-BK
	MR-QRC-28x1.2x2-K-YE
	MR-QRC-28x1.2x2-K-BU
	MR-QRC-28x1.2x2-K-GN
	MR-QRC-28x1.2x2-K-OE
	MR-QRC-28x1.2x2-K-PU
	MR-QRC-28x1.2x2-K-GY

QRC-HP-25-M











Colour	Ordering Codes
	MR-QRC-32.1x1.2x2-RD
	MR-QRC-32.1x1.2x2-BK
	MR-QRC-32.1x1.2x2-YE
	MR-QRC-32.1x1.2x2-BU
	MR-QRC-32.1x1.2x2-GN
	MR-QRC-32.1x1.2x2-OE
	MR-QRC-32.1x1.2x2-PU
	MR-QRC-32.1x1.2x2-GY

Note: The matching of the colour marking rings applies to all connection types of the couplings in the respective nominal sizes.



**On request: Two-Tone Colour Marking Rings for Male Tips
Series QRC-HP-M**
QRC-HP-19-M

Colour	Ordering Codes
	MR-QRC-28x1.2x1-K-RD
	MR-QRC-28x1.2x1-K-BK
	MR-QRC-28x1.2x1-K-YE
	MR-QRC-28x1.2x1-K-BU
	MR-QRC-28x1.2x1-K-GN
	MR-QRC-28x1.2x1-K-OE
	MR-QRC-28x1.2x1-K-PU
	MR-QRC-28x1.2x1-K-GY

Note: Two-Tone Colour Marking Rings are available on request. Please contact STAUFF for an individual offer.



Colour Marking Rings for Female Bodies
Series QRC-HS-F

QRC-HS-06-F



Colour	Ordering Codes
	MR-QRC-20.1x1.2x2-K-RD
	MR-QRC-20.1x1.2x2-K-BK
	MR-QRC-20.1x1.2x2-K-YE
	MR-QRC-20.1x1.2x2-K-BU
	MR-QRC-20.1x1.2x2-K-GN
	MR-QRC-20.1x1.2x2-K-OE
	MR-QRC-20.1x1.2x2-K-PU
	MR-QRC-20.1x1.2x2-K-GY

QRC-HS-10-F



Colour	Ordering Codes
	MR-QRC-24.1x1.2x3.6-K-RD
	MR-QRC-24.1x1.2x3.6-K-BK
	MR-QRC-24.1x1.2x3.6-K-YE
	MR-QRC-24.1x1.2x3.6-K-BU
	MR-QRC-24.1x1.2x3.6-K-GN
	MR-QRC-24.1x1.2x3.6-K-OE
	MR-QRC-24.1x1.2x3.6-K-PU
	MR-QRC-24.1x1.2x3.6-K-GY

QRC-HS-12-F



Colour	Ordering Codes
	QRC-29.9x1.2x4-K-RD
	QRC-29.9x1.2x4-K-BK
	QRC-29.9x1.2x4-K-YE
	QRC-29.9x1.2x4-K-BU
	QRC-29.9x1.2x4-K-GN
	QRC-29.9x1.2x4-K-OE
	QRC-29.9x1.2x4-K-PU
	QRC-29.9x1.2x4-K-GY

QRC-HS-19-F



Colour	Ordering Codes
	MR-QRC-37.9x1.4x4-K-RD
	MR-QRC-37.9x1.4x4-K-BK
	MR-QRC-37.9x1.4x4-K-YE
	MR-QRC-37.9x1.4x4-K-BU
	MR-QRC-37.9x1.4x4-K-GN
	MR-QRC-37.9x1.4x4-K-OE
	MR-QRC-37.9x1.4x4-K-PU
	MR-QRC-37.9x1.4x4-K-GY

QRC-HS-25-F



Colour	Ordering Codes
	MR-QRC-43.5x1.4x5-K-RD
	MR-QRC-43.5x1.4x5-K-BK
	MR-QRC-43.5x1.4x5-K-YE
	MR-QRC-43.5x1.4x5-K-BU
	MR-QRC-43.5x1.4x5-K-GN
	MR-QRC-43.5x1.4x5-K-OE
	MR-QRC-43.5x1.4x5-K-PU
	MR-QRC-43.5x1.4x5-K-GY

QRC-HS-38-F



Colour	Ordering Codes
	MR-QRC-65x1.4x6-K-RD
	MR-QRC-65x1.4x6-K-BK
	MR-QRC-65x1.4x6-K-YE
	MR-QRC-65x1.4x6-K-BU
	MR-QRC-65x1.4x6-K-GN
	MR-QRC-65x1.4x6-K-OE
	MR-QRC-65x1.4x6-K-PU
	MR-QRC-65x1.4x6-K-GY

Note: The matching of the colour marking rings applies to all connection types of the couplings in the respective nominal sizes.



On request: Two-Tone Colour Marking Rings for Female Bodies
 Series QRC-HS-F

QRC-HS-10-F



Colour	Ordering Codes
	MR-QRC-24.1x1.2x1.8-K-RD
	MR-QRC-24.1x1.2x1.8-K-BK
	MR-QRC-24.1x1.2x1.8-K-YE
	MR-QRC-24.1x1.2x1.8-K-BU
	MR-QRC-24.1x1.2x1.8-K-GN
	MR-QRC-24.1x1.2x1.8-K-OE
	MR-QRC-24.1x1.2x1.8-K-PU
	MR-QRC-24.1x1.2x1.8-K-GY

QRC-HS-12-F



Colour	Ordering Codes
	QRC-29.9x1.2x2-K-RD
	QRC-29.9x1.2x2-K-BK
	QRC-29.9x1.2x2-K-YE
	QRC-29.9x1.2x2-K-BU
	QRC-29.9x1.2x2-K-GN
	QRC-29.9x1.2x2-K-OE
	QRC-29.9x1.2x2-K-PU
	QRC-29.9x1.2x2-K-GY

QRC-HS-19-F



Colour	Ordering Codes
	MR-QRC-37.9x1.4x2-K-RD
	MR-QRC-37.9x1.4x2-K-BK
	MR-QRC-37.9x1.4x2-K-YE
	MR-QRC-37.9x1.4x2-K-BU
	MR-QRC-37.9x1.4x2-K-GN
	MR-QRC-37.9x1.4x2-K-OE
	MR-QRC-37.9x1.4x2-K-PU
	MR-QRC-37.9x1.4x2-K-GY

QRC-HS-25-F



Colour	Ordering Codes
	MR-QRC-43.5x1.4x2.5-K-RD
	MR-QRC-43.5x1.4x2.5-K-BK
	MR-QRC-43.5x1.4x2.5-K-YE
	MR-QRC-43.5x1.4x2.5-K-BU
	MR-QRC-43.5x1.4x2.5-K-GN
	MR-QRC-43.5x1.4x2.5-K-OE
	MR-QRC-43.5x1.4x2.5-K-PU
	MR-QRC-43.5x1.4x2.5-K-GY

Note: Two-Tone Colour Marking Rings are available on request. Please contact STAUFF for an individual offer.



Colour Marking Rings for Male Tips
Series QRC-HS-M

QRC-HS-06-M



Colour	Ordering Codes
	MR-QRC-29.9x1.2x4-K-RD
	MR-QRC-29.9x1.2x4-K-BK
	MR-QRC-29.9x1.2x4-K-YE
	MR-QRC-29.9x1.2x4-K-BU
	MR-QRC-29.9x1.2x4-K-GN
	MR-QRC-29.9x1.2x4-K-OE
	MR-QRC-29.9x1.2x4-K-PU
	MR-QRC-29.9x1.2x4-K-GY

QRC-HS-10-M



Colour	Ordering Codes
	MR-QRC-29.9x1.2x4-K-RD
	MR-QRC-29.9x1.2x4-K-BK
	MR-QRC-29.9x1.2x4-K-YE
	MR-QRC-29.9x1.2x4-K-BU
	MR-QRC-29.9x1.2x4-K-GN
	MR-QRC-29.9x1.2x4-K-OE
	MR-QRC-29.9x1.2x4-K-PU
	MR-QRC-29.9x1.2x4-K-GY

QRC-HS-12-M



Colour	Ordering Codes
	MR-QRC-37.9x1.4x4-K-RD
	MR-QRC-37.9x1.4x4-K-BK
	MR-QRC-37.9x1.4x4-K-YE
	MR-QRC-37.9x1.4x4-K-BU
	MR-QRC-37.9x1.4x4-K-GN
	MR-QRC-37.9x1.4x4-K-OE
	MR-QRC-37.9x1.4x4-K-PU
	MR-QRC-37.9x1.4x4-K-GY

QRC-HS-19-M



Colour	Ordering Codes
	MR-QRC-43.5x1.4x5-K-RD
	MR-QRC-43.5x1.4x5-K-BK
	MR-QRC-43.5x1.4x5-K-YE
	MR-QRC-43.5x1.4x5-K-BU
	MR-QRC-43.5x1.4x5-K-GN
	MR-QRC-43.5x1.4x5-K-OE
	MR-QRC-43.5x1.4x5-K-PU
	MR-QRC-43.5x1.4x5-K-GY

QRC-HS-25-M



Colour	Ordering Codes
	MR-QRC-49.4x1.4x5-K-RD
	MR-QRC-49.4x1.4x5-K-BK
	MR-QRC-49.4x1.4x5-K-YE
	MR-QRC-49.4x1.4x5-K-BU
	MR-QRC-49.4x1.4x5-K-GN
	MR-QRC-49.4x1.4x5-K-OE
	MR-QRC-49.4x1.4x5-K-PU
	MR-QRC-49.4x1.4x5-K-GY

QRC-HS-38-M



Colour	Ordering Codes
	MR-QRC-75.2x1.4x7.5-K-RD
	MR-QRC-75.2x1.4x7.5-K-BK
	MR-QRC-75.2x1.4x7.5-K-YE
	MR-QRC-75.2x1.4x7.5-K-BU
	MR-QRC-75.2x1.4x7.5-K-GN
	MR-QRC-75.2x1.4x7.5-K-OE
	MR-QRC-75.2x1.4x7.5-K-PU
	MR-QRC-75.2x1.4x7.5-K-GY

Note: The matching of the colour marking rings applies to all connection types of the couplings in the respective nominal sizes.



On request: Two-Tone Colour Marking Rings for Male Tips Series QRC-HS-M

QRC-HS-10-M



Colour	Ordering Codes
	MR-QRC-29.9x1.2x2-K-RD
	MR-QRC-29.9x1.2x2-K-BK
	MR-QRC-29.9x1.2x2-K-YE
	MR-QRC-29.9x1.2x2-K-BU
	MR-QRC-29.9x1.2x2-K-GN
	MR-QRC-29.9x1.2x2-K-OE
	MR-QRC-29.9x1.2x2-K-PU
	MR-QRC-29.9x1.2x2-K-GY

QRC-HS-12-M



Colour	Ordering Codes
	MR-QRC-37.9x1.4x2-K-RD
	MR-QRC-37.9x1.4x2-K-BK
	MR-QRC-37.9x1.4x2-K-YE
	MR-QRC-37.9x1.4x2-K-BU
	MR-QRC-37.9x1.4x2-K-GN
	MR-QRC-37.9x1.4x2-K-OE
	MR-QRC-37.9x1.4x2-K-PU
	MR-QRC-37.9x1.4x2-K-GY

QRC-HS-19-M



Colour	Ordering Codes
	MR-QRC-43.5x1.4x2.5-K-RD
	MR-QRC-43.5x1.4x2.5-K-BK
	MR-QRC-43.5x1.4x2.5-K-YE
	MR-QRC-43.5x1.4x2.5-K-BU
	MR-QRC-43.5x1.4x2.5-K-GN
	MR-QRC-43.5x1.4x2.5-K-OE
	MR-QRC-43.5x1.4x2.5-K-PU
	MR-QRC-43.5x1.4x2.5-K-GY

QRC-HS-25-M



Colour	Ordering Codes
	MR-QRC-49.4x1.4x2.5-K-RD
	MR-QRC-49.4x1.4x2.5-K-BK
	MR-QRC-49.4x1.4x2.5-K-YE
	MR-QRC-49.4x1.4x2.5-K-BU
	MR-QRC-49.4x1.4x2.5-K-GN
	MR-QRC-49.4x1.4x2.5-K-OE
	MR-QRC-49.4x1.4x2.5-K-PU
	MR-QRC-49.4x1.4x2.5-K-GY

Note: Two-Tone Colour Marking Rings are available on request. Please contact STAUFF for an individual offer.



Colour Marking Rings for Male Tips
Series QRC-HS-M-HX (Version with Hexagonal Sleeve)

QRC-HS-06-M-HX



Colour	Ordering Codes
	MR-QRC-28x1.2x4-K-RD
	MR-QRC-28x1.2x4-K-BK
	MR-QRC-28x1.2x4-K-YE
	MR-QRC-28x1.2x4-K-BU
	MR-QRC-28x1.2x4-K-GN
	MR-QRC-28x1.2x4-K-OE
	MR-QRC-28x1.2x4-K-PU
	MR-QRC-28x1.2x4-K-GY

QRC-HS-10-M-HX



Colour	Ordering Codes
	MR-QRC-32.1x1.2x4-K-RD
	MR-QRC-32.1x1.2x4-K-BK
	MR-QRC-32.1x1.2x4-K-YE
	MR-QRC-32.1x1.2x4-K-BU
	MR-QRC-32.1x1.2x4-K-GN
	MR-QRC-32.1x1.2x4-K-OE
	MR-QRC-32.1x1.2x4-K-PU
	MR-QRC-32.1x1.2x4-K-GY

QRC-HS-12-M-HX



Colour	Ordering Codes
	MR-QRC-41.1x1.4x4-K-RD
	MR-QRC-41.1x1.4x4-K-BK
	MR-QRC-41.1x1.4x4-K-YE
	MR-QRC-41.1x1.4x4-K-BU
	MR-QRC-41.1x1.4x4-K-GN
	MR-QRC-41.1x1.4x4-K-OE
	MR-QRC-41.1x1.4x4-K-PU
	MR-QRC-41.1x1.4x4-K-GY

QRC-HS-19-M-HX



Colour	Ordering Codes
	MR-QRC-46.1x1.4x5-K-RD
	MR-QRC-46.1x1.4x5-K-BK
	MR-QRC-46.1x1.4x5-K-YE
	MR-QRC-46.1x1.4x5-K-BU
	MR-QRC-46.1x1.4x5-K-GN
	MR-QRC-46.1x1.4x5-K-OE
	MR-QRC-46.1x1.4x5-K-PU
	MR-QRC-46.1x1.4x5-K-GY

QRC-HS-25-M-HX



Colour	Ordering Codes
	MR-QRC-49.4x1.4x5-K-RD
	MR-QRC-49.4x1.4x5-K-BK
	MR-QRC-49.4x1.4x5-K-YE
	MR-QRC-49.4x1.4x5-K-BU
	MR-QRC-49.4x1.4x5-K-GN
	MR-QRC-49.4x1.4x5-K-OE
	MR-QRC-49.4x1.4x5-K-PU
	MR-QRC-49.4x1.4x5-K-GY

Note: The matching of the colour marking rings applies to all connection types of the couplings in the respective nominal sizes.



On request: Two-Tone Colour Marking Rings for Male Tips Series QRC-HS-M-HX (Version with Hexagonal Sleeve)
QRC-HS-06-M-HX

Colour	Ordering Codes
	MR-QRC-28x1.2x2-K-RD
	MR-QRC-28x1.2x2-K-BK
	MR-QRC-28x1.2x2-K-YE
	MR-QRC-28x1.2x2-K-BU
	MR-QRC-28x1.2x2-K-GN
	MR-QRC-28x1.2x2-K-OE
	MR-QRC-28x1.2x2-K-PU
	MR-QRC-28x1.2x2-K-GY

QRC-HS-10-M-HX



Colour	Ordering Codes
	MR-QRC-32.1x1.2x2-K-RD
	MR-QRC-32.1x1.2x2-K-BK
	MR-QRC-32.1x1.2x2-K-YE
	MR-QRC-32.1x1.2x2-K-BU
	MR-QRC-32.1x1.2x2-K-GN
	MR-QRC-32.1x1.2x2-K-OE
	MR-QRC-32.1x1.2x2-K-PU
	MR-QRC-32.1x1.2x2-K-GY

QRC-HS-12-M-HX

Colour	Ordering Codes
	MR-QRC-41.1x1.4x2-K-RD
	MR-QRC-41.1x1.4x2-K-BK
	MR-QRC-41.1x1.4x2-K-YE
	MR-QRC-41.1x1.4x2-K-BU
	MR-QRC-41.1x1.4x2-K-GN
	MR-QRC-41.1x1.4x2-K-OE
	MR-QRC-41.1x1.4x2-K-PU
	MR-QRC-41.1x1.4x2-K-GY

QRC-HS-19-M-HX

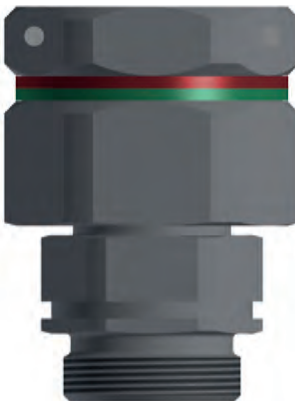
Colour	Ordering Codes
	MR-QRC-46.1x1.4x2.5-K-RD
	MR-QRC-46.1x1.4x2.5-K-BK
	MR-QRC-46.1x1.4x2.5-K-YE
	MR-QRC-46.1x1.4x2.5-K-BU
	MR-QRC-46.1x1.4x2.5-K-GN
	MR-QRC-46.1x1.4x2.5-K-OE
	MR-QRC-46.1x1.4x2.5-K-PU
	MR-QRC-46.1x1.4x2.5-K-GY

QRC-HS-25-M-HX

Colour	Ordering Codes
	MR-QRC-49.4x1.4x2.5-K-RD
	MR-QRC-49.4x1.4x2.5-K-BK
	MR-QRC-49.4x1.4x2.5-K-YE
	MR-QRC-49.4x1.4x2.5-K-BU
	MR-QRC-49.4x1.4x2.5-K-GN
	MR-QRC-49.4x1.4x2.5-K-OE
	MR-QRC-49.4x1.4x2.5-K-PU
	MR-QRC-49.4x1.4x2.5-K-GY

Note: Two-Tone Colour Marking Rings are available on request. Please contact STAUFF for an individual offer.



Colour Marking Rings for Female Bodies Series QRC-RH-F

QRC-RH-10-F



Colour	Ordering Codes
	MR-QRC-25.9x1.2x3.8-K-RD
	MR-QRC-25.9x1.2x3.8-K-BK
	MR-QRC-25.9x1.2x3.8-K-YE
	MR-QRC-25.9x1.2x3.8-K-BU
	MR-QRC-25.9x1.2x3.8-K-GN
	MR-QRC-25.9x1.2x3.8-K-OE
	MR-QRC-25.9x1.2x3.8-K-PU
	MR-QRC-25.9x1.2x3.8-K-GY

QRC-RH-12-F



Colour	Ordering Codes
	MR-QRC-29.9x1.2x4-K-RD
	MR-QRC-29.9x1.2x4-K-BK
	MR-QRC-29.9x1.2x4-K-YE
	MR-QRC-29.9x1.2x4-K-BU
	MR-QRC-29.9x1.2x4-K-GN
	MR-QRC-29.9x1.2x4-K-OE
	MR-QRC-29.9x1.2x4-K-PU
	MR-QRC-29.9x1.2x4-K-GY

QRC-RH-16-F



Colour	Ordering Codes
	MR-QRC-41.1x1.4x4-K-RD
	MR-QRC-41.1x1.4x4-K-BK
	MR-QRC-41.1x1.4x4-K-YE
	MR-QRC-41.1x1.4x4-K-BU
	MR-QRC-41.1x1.4x4-K-GN
	MR-QRC-41.1x1.4x4-K-OE
	MR-QRC-41.1x1.4x4-K-PU
	MR-QRC-41.1x1.4x4-K-GY

QRC-RH-19-F



Colour	Ordering Codes
	MR-QRC-46.1x1.4x5-K-RD
	MR-QRC-46.1x1.4x5-K-BK
	MR-QRC-46.1x1.4x5-K-YE
	MR-QRC-46.1x1.4x5-K-BU
	MR-QRC-46.1x1.4x5-K-GN
	MR-QRC-46.1x1.4x5-K-OE
	MR-QRC-46.1x1.4x5-K-PU
	MR-QRC-46.1x1.4x5-K-GY

QRC-RH-25-F



Colour	Ordering Codes
	MR-QRC-70.2x1.4x5-K-RD
	MR-QRC-70.2x1.4x5-K-BK
	MR-QRC-70.2x1.4x5-K-YE
	MR-QRC-70.2x1.4x5-K-BU
	MR-QRC-70.2x1.4x5-K-GN
	MR-QRC-70.2x1.4x5-K-OE
	MR-QRC-70.2x1.4x5-K-PU
	MR-QRC-70.2x1.4x5-K-GY

When using a dust cover for female Bodies, the colour marking must be done via the marking clips.



On request: Two-Tone Colour Marking Rings for Female Bodies
 Series QRC-RH-F

QRC-RH-10-F



Colour	Ordering Codes
	MR-QRC-25.9x1.2x1.9-K-RD
	MR-QRC-25.9x1.2x1.9-K-BK
	MR-QRC-25.9x1.2x1.9-K-YE
	MR-QRC-25.9x1.2x1.9-K-BU
	MR-QRC-25.9x1.2x1.9-K-GN
	MR-QRC-25.9x1.2x1.9-K-OE
	MR-QRC-25.9x1.2x1.9-K-PU
	MR-QRC-25.9x1.2x1.9-K-GY

QRC-RH-12-F



Colour	Ordering Codes
	MR-QRC-29.9x1.2x2-K-RD
	MR-QRC-29.9x1.2x2-K-BK
	MR-QRC-29.9x1.2x2-K-YE
	MR-QRC-29.9x1.2x2-K-BU
	MR-QRC-29.9x1.2x2-K-GN
	MR-QRC-29.9x1.2x2-K-OE
	MR-QRC-29.9x1.2x2-K-PU
	MR-QRC-29.9x1.2x2-K-GY

QRC-RH-16-F



Colour	Ordering Codes
	MR-QRC-41.1x1.4x2-K-RD
	MR-QRC-41.1x1.4x2-K-BK
	MR-QRC-41.1x1.4x2-K-YE
	MR-QRC-41.1x1.4x2-K-BU
	MR-QRC-41.1x1.4x2-K-GN
	MR-QRC-41.1x1.4x2-K-OE
	MR-QRC-41.1x1.4x2-K-PU
	MR-QRC-41.1x1.4x2-K-GY

QRC-RH-19-F



Colour	Ordering Codes
	MR-QRC-46.1x1.4x2.5-K-RD
	MR-QRC-46.1x1.4x2.5-K-BK
	MR-QRC-46.1x1.4x2.5-K-YE
	MR-QRC-46.1x1.4x2.5-K-BU
	MR-QRC-46.1x1.4x2.5-K-GN
	MR-QRC-46.1x1.4x2.5-K-OE
	MR-QRC-46.1x1.4x2.5-K-PU
	MR-QRC-46.1x1.4x2.5-K-GY

When using a dust cover for female Bodies, the colour marking must be done via the marking clips.

Note: Two-Tone Colour Marking Rings are available on request. Please contact STAUFF for an individual offer.



Colour Marking Rings for Male Tips
Series QRC-RH-M

QRC-RH-10-M



Colour	Ordering Codes
	MR-QRC-35.6x1.2x4-K-RD
	MR-QRC-35.6x1.2x4-K-BK
	MR-QRC-35.6x1.2x4-K-YE
	MR-QRC-35.6x1.2x4-K-BU
	MR-QRC-35.6x1.2x4-K-GN
	MR-QRC-35.6x1.2x4-K-OE
	MR-QRC-35.6x1.2x4-K-PU
	MR-QRC-35.6x1.2x4-K-GY

QRC-RH-12-M



Colour	Ordering Codes
	MR-QRC-41.1x1.4x4-K-RD
	MR-QRC-41.1x1.4x4-K-BK
	MR-QRC-41.1x1.4x4-K-YE
	MR-QRC-41.1x1.4x4-K-BU
	MR-QRC-41.1x1.4x4-K-GN
	MR-QRC-41.1x1.4x4-K-OE
	MR-QRC-41.1x1.4x4-K-PU
	MR-QRC-41.1x1.4x4-K-GY

QRC-RH-16-M



Colour	Ordering Codes
	MR-QRC-53.8x1.4x6-K-RD
	MR-QRC-53.8x1.4x6-K-BK
	MR-QRC-53.8x1.4x6-K-YE
	MR-QRC-53.8x1.4x6-K-BU
	MR-QRC-53.8x1.4x6-K-GN
	MR-QRC-53.8x1.4x6-K-OE
	MR-QRC-53.8x1.4x6-K-PU
	MR-QRC-53.8x1.4x6-K-GY

QRC-RH-19-M



Colour	Ordering Codes
	MR-QRC-59.3x1.4x6-K-RD
	MR-QRC-59.3x1.4x6-K-BK
	MR-QRC-59.3x1.4x6-K-YE
	MR-QRC-59.3x1.4x6-K-BU
	MR-QRC-59.3x1.4x6-K-GN
	MR-QRC-59.3x1.4x6-K-OE
	MR-QRC-59.3x1.4x6-K-PU
	MR-QRC-59.3x1.4x6-K-GY

QRC-RH-25-M



Colour	Ordering Codes
	MR-QRC-84.8x1.4x10-K-RD
	MR-QRC-84.8x1.4x10-K-BK
	MR-QRC-84.8x1.4x10-K-YE
	MR-QRC-84.8x1.4x10-K-BU
	MR-QRC-84.8x1.4x10-K-GN
	MR-QRC-84.8x1.4x10-K-OE
	MR-QRC-84.8x1.4x10-K-PU
	MR-QRC-84.8x1.4x10-K-GY

Note: The matching of the colour marking rings applies to all connection types of the couplings in the respective nominal sizes.



On request: Two-Tone Colour Marking Rings for Male Tips Series QRC-RH-M
QRC-RH-10-M

Colour	Ordering Codes
	MR-QRC-35.6x1.2x2-K-RD
	MR-QRC-35.6x1.2x2-K-BK
	MR-QRC-35.6x1.2x2-K-YE
	MR-QRC-35.6x1.2x2-K-BU
	MR-QRC-35.6x1.2x2-K-GN
	MR-QRC-35.6x1.2x2-K-OE
	MR-QRC-35.6x1.2x2-K-PU
	MR-QRC-35.6x1.2x2-K-GY

QRC-RH-12-M

Colour	Ordering Codes
	MR-QRC-41.1x1.4x2-K-RD
	MR-QRC-41.1x1.4x2-K-BK
	MR-QRC-41.1x1.4x2-K-YE
	MR-QRC-41.1x1.4x2-K-BU
	MR-QRC-41.1x1.4x2-K-GN
	MR-QRC-41.1x1.4x2-K-OE
	MR-QRC-41.1x1.4x2-K-PU
	MR-QRC-41.1x1.4x2-K-GY

QRC-RH-16-M

Colour	Ordering Codes
	MR-QRC-53.8x1.4x3-K-RD
	MR-QRC-53.8x1.4x3-K-BK
	MR-QRC-53.8x1.4x3-K-YE
	MR-QRC-53.8x1.4x3-K-BU
	MR-QRC-53.8x1.4x3-K-GN
	MR-QRC-53.8x1.4x3-K-OE
	MR-QRC-53.8x1.4x3-K-PU
	MR-QRC-53.8x1.4x3-K-GY

QRC-RH-19-M

Colour	Ordering Codes
	MR-QRC-59.3x1.4x3-K-RD
	MR-QRC-59.3x1.4x3-K-BK
	MR-QRC-59.3x1.4x3-K-YE
	MR-QRC-59.3x1.4x3-K-BU
	MR-QRC-59.3x1.4x3-K-GN
	MR-QRC-59.3x1.4x3-K-OE
	MR-QRC-59.3x1.4x3-K-PU
	MR-QRC-59.3x1.4x3-K-GY

Note: Two-Tone Colour Marking Rings are available on request. Please contact STAUFF for an individual offer.



Colour Marking Rings for Female Bodies
Series QRC-FG-F

QRC-FG-10-F



Colour	Ordering Codes
	MR-QRC-33.7x1.2x3.8-K-RD
	MR-QRC-33.7x1.2x3.8-K-BK
	MR-QRC-33.7x1.2x3.8-K-YE
	MR-QRC-33.7x1.2x3.8-K-BU
	MR-QRC-33.7x1.2x3.8-K-GN
	MR-QRC-33.7x1.2x3.8-K-OE
	MR-QRC-33.7x1.2x3.8-K-PU
	MR-QRC-33.7x1.2x3.8-K-GY

QRC-FG-12-F

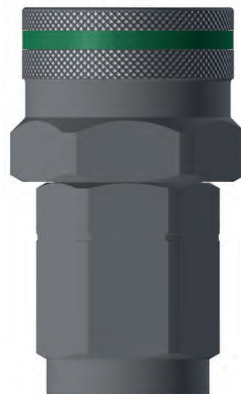

Colour	Ordering Codes
	MR-QRC-41.1x1.4x4-K-RD
	MR-QRC-41.1x1.4x4-K-BK
	MR-QRC-41.1x1.4x4-K-YE
	MR-QRC-41.1x1.4x4-K-BU
	MR-QRC-41.1x1.4x4-K-GN
	MR-QRC-41.1x1.4x4-K-OE
	MR-QRC-41.1x1.4x4-K-PU
	MR-QRC-41.1x1.4x4-K-GY

QRC-FG-16-F



Colour	Ordering Codes
	MR-QRC-46.1x1.4x5-K-RD
	MR-QRC-46.1x1.4x5-K-BK
	MR-QRC-46.1x1.4x5-K-YE
	MR-QRC-46.1x1.4x5-K-BU
	MR-QRC-46.1x1.4x5-K-GN
	MR-QRC-46.1x1.4x5-K-OE
	MR-QRC-46.1x1.4x5-K-PU
	MR-QRC-46.1x1.4x5-K-GY

QRC-FG-19-F



Colour	Ordering Codes
	MR-QRC-49.4x.1.4x5-K-RD
	MR-QRC-49.4x.1.4x5-K-BK
	MR-QRC-49.4x.1.4x5-K-YE
	MR-QRC-49.4x.1.4x5-K-BU
	MR-QRC-49.4x.1.4x5-K-GN
	MR-QRC-49.4x.1.4x5-K-OE
	MR-QRC-49.4x.1.4x5-K-PU
	MR-QRC-49.4x.1.4x5-K-GY

QRC-FG-25-F



Colour	Ordering Codes
	MR-QRC-59.3x.1.4x6-K-RD
	MR-QRC-59.3x.1.4x6-K-BK
	MR-QRC-59.3x.1.4x6-K-YE
	MR-QRC-59.3x.1.4x6-K-BU
	MR-QRC-59.3x.1.4x6-K-GN
	MR-QRC-59.3x.1.4x6-K-OE
	MR-QRC-59.3x.1.4x6-K-PU
	MR-QRC-59.3x.1.4x6-K-GY

Note: The matching of the colour marking rings applies to all connection types of the couplings in the respective nominal sizes.



On request: Two-Tone Colour Marking Rings for Female Bodies
 Series QRC-FG-F

QRC-FG-10-F

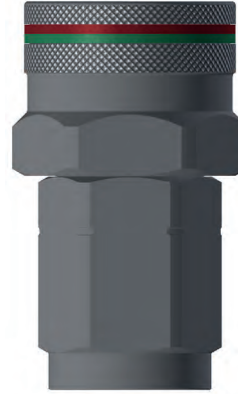

Colour	Ordering Codes
	MR-QRC-33.7x1.2x1.9-K-RD
	MR-QRC-33.7x1.2x1.9-K-BK
	MR-QRC-33.7x1.2x1.9-K-YE
	MR-QRC-33.7x1.2x1.9-K-BU
	MR-QRC-33.7x1.2x1.9-K-GN
	MR-QRC-33.7x1.2x1.9-K-OE
	MR-QRC-33.7x1.2x1.9-K-PU
	MR-QRC-33.7x1.2x1.9-K-GY

QRC-FG-12-F

Colour	Ordering Codes
	MR-QRC-41.1x1.4x2-K-RD
	MR-QRC-41.1x1.4x2-K-BK
	MR-QRC-41.1x1.4x2-K-YE
	MR-QRC-41.1x1.4x2-K-BU
	MR-QRC-41.1x1.4x2-K-GN
	MR-QRC-41.1x1.4x2-K-OE
	MR-QRC-41.1x1.4x2-K-PU
	MR-QRC-41.1x1.4x2-K-GY

QRC-FG-16-F

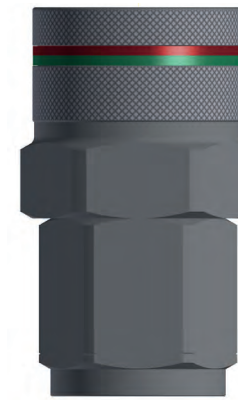
Colour	Ordering Codes
	MR-QRC-46.1x1.4x2-K-RD
	MR-QRC-46.1x1.4x2-K-BK
	MR-QRC-46.1x1.4x2-K-YE
	MR-QRC-46.1x1.4x2-K-BU
	MR-QRC-46.1x1.4x2-K-GN
	MR-QRC-46.1x1.4x2-K-OE
	MR-QRC-46.1x1.4x2-K-PU
	MR-QRC-46.1x1.4x2-K-GY

QRC-FG-19-F

Colour	Ordering Codes
	MR-QRC-49.4x.1.4x2.5-K-RD
	MR-QRC-49.4x.1.4x2.5-K-BK
	MR-QRC-49.4x.1.4x2.5-K-YE
	MR-QRC-49.4x.1.4x2.5-K-BU
	MR-QRC-49.4x.1.4x2.5-K-GN
	MR-QRC-49.4x.1.4x2.5-K-OE
	MR-QRC-49.4x.1.4x2.5-K-PU
	MR-QRC-49.4x.1.4x2.5-K-GY

QRC-FG-25-F

Colour	Ordering Codes
	MR-QRC-59.3x.1.4x3-K-RD
	MR-QRC-59.3x.1.4x3-K-BK
	MR-QRC-59.3x.1.4x3-K-YE
	MR-QRC-59.3x.1.4x3-K-BU
	MR-QRC-59.3x.1.4x3-K-GN
	MR-QRC-59.3x.1.4x3-K-OE
	MR-QRC-59.3x.1.4x3-K-PU
	MR-QRC-59.3x.1.4x3-K-GY

Note: Two-Tone Colour Marking Rings are available on request. Please contact STAUFF for an individual offer.



Colour Marking Rings for Male Tips
Series QRC-FG-M

QRC-FG-10-M



Colour	Ordering Codes
	MR-QRC-33.7x1.2x3.8-K-RD
	MR-QRC-33.7x1.2x3.8-K-BK
	MR-QRC-33.7x1.2x3.8-K-YE
	MR-QRC-33.7x1.2x3.8-K-BU
	MR-QRC-33.7x1.2x3.8-K-GN
	MR-QRC-33.7x1.2x3.8-K-OE
	MR-QRC-33.7x1.2x3.8-K-PU
	MR-QRC-33.7x1.2x3.8-K-GY

QRC-FG-12-M



Colour	Ordering Codes
	MR-QRC-41.1x1.4x4-K-RD
	MR-QRC-41.1x1.4x4-K-BK
	MR-QRC-41.1x1.4x4-K-YE
	MR-QRC-41.1x1.4x4-K-BU
	MR-QRC-41.1x1.4x4-K-GN
	MR-QRC-41.1x1.4x4-K-OE
	MR-QRC-41.1x1.4x4-K-PU
	MR-QRC-41.1x1.4x4-K-GY

QRC-FG-16-M



Colour	Ordering Codes
	MR-QRC-46.1x1.4x5-K-RD
	MR-QRC-46.1x1.4x5-K-BK
	MR-QRC-46.1x1.4x5-K-YE
	MR-QRC-46.1x1.4x5-K-BU
	MR-QRC-46.1x1.4x5-K-GN
	MR-QRC-46.1x1.4x5-K-OE
	MR-QRC-46.1x1.4x5-K-PU
	MR-QRC-46.1x1.4x5-K-GY

QRC-FG-19-M



Colour	Ordering Codes
	MR-QRC-49.4x1.4x5-K-RD
	MR-QRC-49.4x1.4x5-K-BK
	MR-QRC-49.4x1.4x5-K-YE
	MR-QRC-49.4x1.4x5-K-BU
	MR-QRC-49.4x1.4x5-K-GN
	MR-QRC-49.4x1.4x5-K-OE
	MR-QRC-49.4x1.4x5-K-PU
	MR-QRC-49.4x1.4x5-K-GY

QRC-FG-25-M



Colour	Ordering Codes
	MR-QRC-59.3x1.4x6-K-RD
	MR-QRC-59.3x1.4x6-K-BK
	MR-QRC-59.3x1.4x6-K-YE
	MR-QRC-59.3x1.4x6-K-BU
	MR-QRC-59.3x1.4x6-K-GN
	MR-QRC-59.3x1.4x6-K-OE
	MR-QRC-59.3x1.4x6-K-PU
	MR-QRC-59.3x1.4x6-K-GY

Note: The matching of the colour marking rings applies to all connection types of the couplings in the respective nominal sizes.



On request: Two-Tone Colour Marking Rings for Male Tips
 Series QRC-FG-M

QRC-FG-10-M



Colour	Ordering Codes
	MR-QRC-33.7x1.2x1.9-K-RD
	MR-QRC-33.7x1.2x1.9-K-BK
	MR-QRC-33.7x1.2x1.9-K-YE
	MR-QRC-33.7x1.2x1.9-K-BU
	MR-QRC-33.7x1.2x1.9-K-GN
	MR-QRC-33.7x1.2x1.9-K-OE
	MR-QRC-33.7x1.2x1.9-K-PU
	MR-QRC-33.7x1.2x1.9-K-GY

QRC-FG-12-M



Colour	Ordering Codes
	MR-QRC-41.1x1.4x2-K-RD
	MR-QRC-41.1x1.4x2-K-BK
	MR-QRC-41.1x1.4x2-K-YE
	MR-QRC-41.1x1.4x2-K-BU
	MR-QRC-41.1x1.4x2-K-GN
	MR-QRC-41.1x1.4x2-K-OE
	MR-QRC-41.1x1.4x2-K-PU
	MR-QRC-41.1x1.4x2-K-GY

QRC-FG-16-M



Colour	Ordering Codes
	MR-QRC-46.1x1.4x2.5-K-RD
	MR-QRC-46.1x1.4x2.5-K-BK
	MR-QRC-46.1x1.4x2.5-K-YE
	MR-QRC-46.1x1.4x2.5-K-BU
	MR-QRC-46.1x1.4x2.5-K-GN
	MR-QRC-46.1x1.4x2.5-K-OE
	MR-QRC-46.1x1.4x2.5-K-PU
	MR-QRC-46.1x1.4x2.5-K-GY

QRC-FG-19-M



Colour	Ordering Codes
	MR-QRC-49.4x1.4x2.5-K-RD
	MR-QRC-49.4x1.4x2.5-K-BK
	MR-QRC-49.4x1.4x2.5-K-YE
	MR-QRC-49.4x1.4x2.5-K-BU
	MR-QRC-49.4x1.4x2.5-K-GN
	MR-QRC-49.4x1.4x2.5-K-OE
	MR-QRC-49.4x1.4x2.5-K-PU
	MR-QRC-49.4x1.4x2.5-K-GY

QRC-FG-25-M



Colour	Ordering Codes
	MR-QRC-59.3x1.4x3-K-RD
	MR-QRC-59.3x1.4x3-K-BK
	MR-QRC-59.3x1.4x3-K-YE
	MR-QRC-59.3x1.4x3-K-BU
	MR-QRC-59.3x1.4x3-K-GN
	MR-QRC-59.3x1.4x3-K-OE
	MR-QRC-59.3x1.4x3-K-PU
	MR-QRC-59.3x1.4x3-K-GY

Note: Two-Tone Colour Marking Rings are available on request. Please contact STAUFF for an individual offer.



Dust cover clips

Description

This dust guard can be fitted to the Female Body after installation for the Series HP and FF. The cap is also available with an optional drill hole for a marking clip.

In addition to the standard colour, other colours are also available on request.

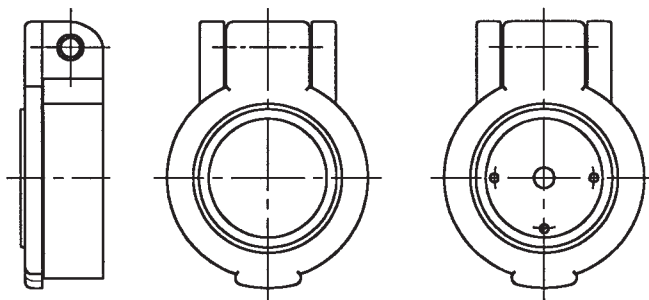

Type	Without bore	With bore
	Ordering Codes	Ordering Codes
HP-10 + FF-10		QRC-SZ-SF-32/L-K-BK
UX-12/HP-12 + FF-12	QRC-SZ-SF-38-K-BK	QRC-SZ-SF-38/L-K-BK
HP-19 + FF-19		QRC-SZ-SF-46/L-K-BK

Dust cover body

Description

The dust guard is used to protect the carrier half against pollution. The cap is also available with an optional drill hole for a marking clip.

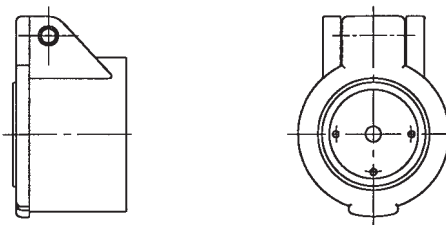

Type	Without bore	With bore
	Ordering Codes	Ordering Codes
RH-10	QRC-RH-10-BF-30-K-BK	QRC-RH-10-BF-30/L-K-BK



Marking Clips

Description

The marking clips are used for identification purposes.



Mark	Colour	Ordering Codes
1	red	QRC-SZ-CL-1-K-RD
2	red	QRC-SZ-CL-2-K-RD
3	green	QRC-SZ-CL-3-K-GN
4	green	QRC-SZ-CL-4-K-GN
5	yellow	QRC-SZ-CL-5-K-YE
6	yellow	QRC-SZ-CL-6-K-YE
7	blue	QRC-SZ-CL-7-K-BU
8	blue	QRC-SZ-CL-8-K-BU
II	white	QRC-SZ-CL-R2-K-WH
III	white	QRC-SZ-CL-R3-K-WH
Rückl.	black	QRC-SZ-CL-T-K-BK
Neutr.	black	QRC-SZ-CL-K-BK

Safety Clamp with 4-hole flange
Description

This safety clamp enables the HP-10 Female Body to be rigidly secured on the vehicle. The carrier is held in the clamp by a spring.

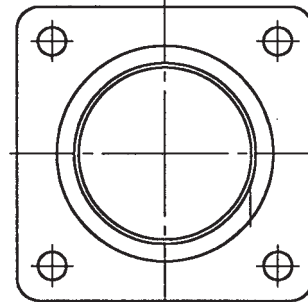
Ordering Codes

QRC-SZ-BH-38-W66

Anchor bracket for Male Tip
Description

The anchor bracket allows the Male Tip to be parked when disconnected. This protects the probe from damage and dirt. The anchor bracket is made of red plastic and fitted with a spring-loaded cap.

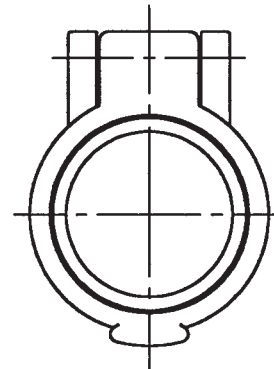
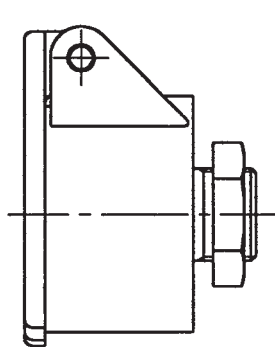
Ordering Codes

QRC-HP-12-MH-M18-K-RD



Seal Kits

Type	Description	Amount	Ordering Codes
for Female Body			
HP-06	O-ring Back up ring	25	QRC-HPA-06-FSK-BT
HP-10	O-ring Back up ring	25	QRC-HP-10-FSK-BT
HP-10A	O-ring Back up ring	20	QRC-HPA-10-FSK-BT
HP-12	O-ring	50	QRC-HP-12-FSK-B
HP-19	O-ring Back up ring	25	QRC-HP-19-FSK-BT
HP-25	O-ring	25	QRC-HP-25-FSK-BT
for Male Tip			
FH-06	Profile packing	25	QRC-FH-06-MSK-PU
FH-10	O-ring Profile packing	25	QRC-FH-10-MSK-BT
FH-12	O-ring Profile packing	25	QRC-FH-12-MSK-BT
FH-16	Profile packing	25	QRC-FH-16-MSK-PU
FH-19	O-ring Profile packing	25	QRC-FH-19-MSK-BT
FH-25	O-ring PTFE ring	10	QRC-FH-25-MSK-BT
for Male Tip			
FF-06	Profile packing	25	QRC-FF-06-MSK-PU
FF-10	Profile packing	25	QRC-FF-10-MSK-PU
FF-12	Profile packing	25	QRC-FF-12-MSK-PU
FF-16	Profile packing	25	QRC-FF-16-MSK-PU
FF-19	Profile packing	25	QRC-FF-19-MSK-PU
FF-25	O-ring PTFE ring	10	QRC-FF-25-MSK-BT
for Female Body			
HS-06	O-ring Back up ring Arrest ring	25	QRC-HS-06-FSK-BT
HS-10	O-ring Back up ring Arrest ring	25	QRC-HS-10-FSK-BT
HS-12	O-ring Back up ring Arrest ring	50	QRC-HS-12-FSK-BT
HS-19	O-ring Back up ring Arrest ring	25	QRC-HS-19-FSK-BT
HS-25	O-ring Back up ring Arrest ring	25	QRC-HS-25-FSK-BT
HS-38	O-ring Back up ring Arrest ring	10	QRC-HS-38-FSK-BT
for Female Body			
PS-25	Back up ring O-ring O-ring	5	QRC-PS-25-FSK-S4

Note: Any disconnection of the coupling leads up to the expiration of the guarantee.



Type	Description	Amount	Ordering Codes
for Male Tip			
FT-10	O-ring	10	QRC-FT-10-MSK-BT
	Profile packing		
FT-12	O-ring	10	QRC-FT-12-MSK-BT
	Profile packing		
FT-16	O-ring	10	QRC-FT-16-MSK-BT
	Profile packing		
FT-19	O-ring	10	QRC-FT-19-MSK-BT
	Profile packing		
FT-31	O-ring	10	QRC-FT-31-MSK-BT
	Profile packing		
for Female Body			
RH-10	O-ring	25	QRC-RH-10-FSK-BT
	Back up ring		
RH-12	O-ring	25	QRC-RH-12-FSK-BT
	Back up ring		
RH-16	O-ring	10	QRC-RH-16-FSK-BT
	Back up ring		
RK-19	O-ring	10	QRC-RK-19-FSK-BT
	Back up ring		
RH-19	O-ring	10	QRC-RH-19-FSK-BT
	Back up ring		
RH-25	O-ring	10	QRC-RH-25-FSK-BT
	Back up ring		
for Female Body			
HI-06	O-ring	10	QRC-HI-06-FSK-BT
	Back up ring		
HI-10	O-ring	10	QRC-HI-10-FSK-BT
	Back up ring		
for Female Body			
HUS-10	Back up ring	25	QRC-HUS-10-FSK-BT
	O-ring		
HUS-12	Back up ring	25	QRC-HUS-12-FSK-BT
	O-ring		
HUS-19	Back up ring	25	QRC-HUS-19-FSK-BT
	O-ring		
HUS-25	Back up ring	25	QRC-HUS-25-FSK-BT
	O-ring		
for Female Body			
IA-06	O-ring	25	QRC-IA-06-FSK-BT
	Back up ring		
IA-10	O-ring	25	QRC-IA-10-FSK-BT
	Back up ring		
IA-12	O-ring	25	QRC-IA-12-FSK-BT
	Back up ring		
IA-19	O-ring	25	QRC-IA-19-FSK-BT
	Back up ring		
IA-25	O-ring	25	QRC-IA-25-FSK-BT
	Back up ring		
for Female Body			
IB-06	O-ring	25	QRC-IB-06-FSK-BT
	Back up ring		
IB-10	O-ring	25	QRC-IB-10-FSK-BT
	Back up ring		
IB-12	O-ring	25	QRC-IB-12-FSK-BT
	Back up ring		
IB-19	O-ring	25	QRC-IB-19-FSK-BT
	Back up ring		
for Female Body			
ID-10	O-ring	25	QRC-ID-10-FSK-BT
	Back up ring		
ID-19	O-ring	25	QRC-ID-19-FSK-BT
	Back up ring		
ID-25	O-ring	25	QRC-ID-25-FSK-BT
	Back up ring		

Note: Any disconnection of the coupling leads up to the expiration of the guarantee.



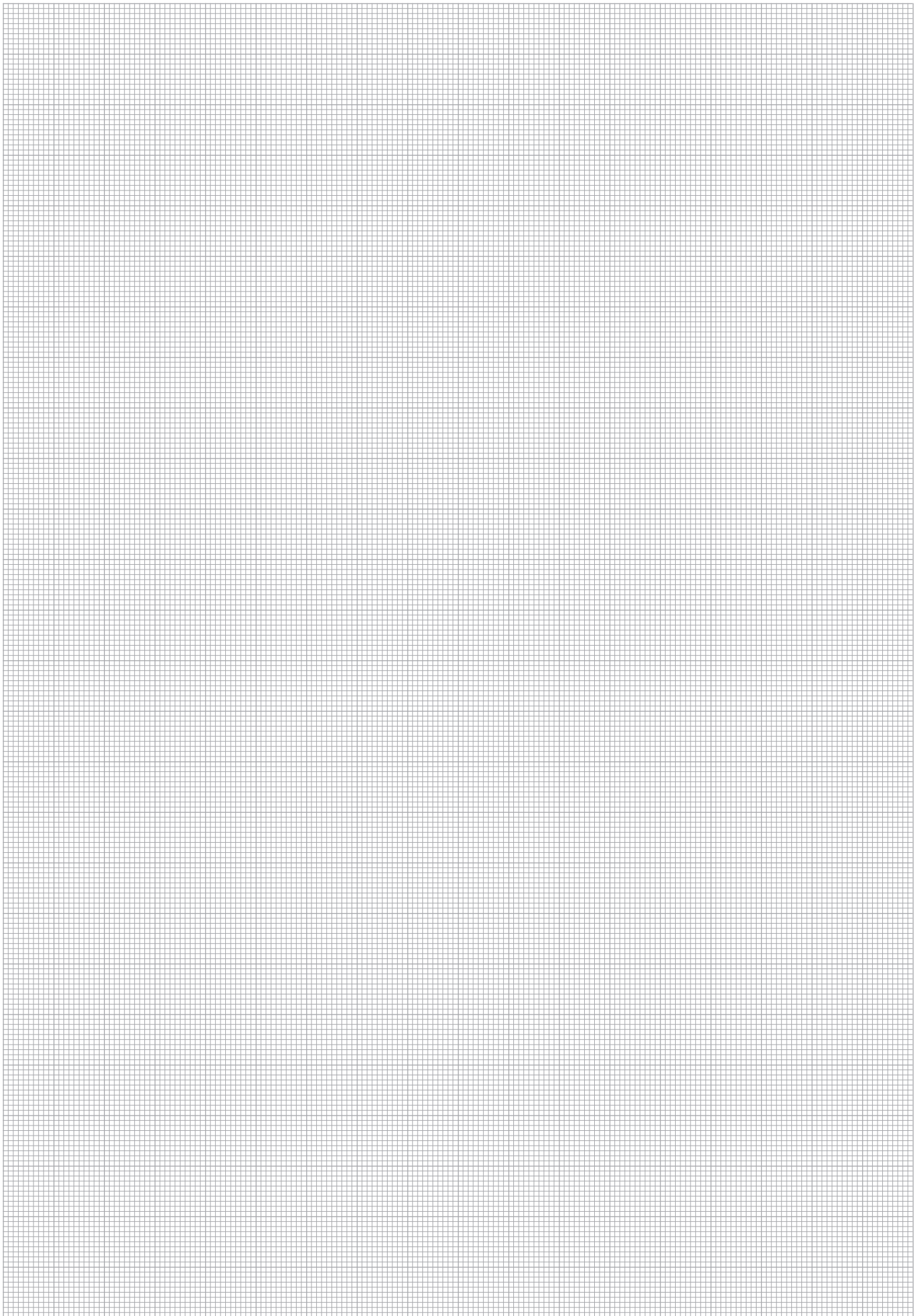

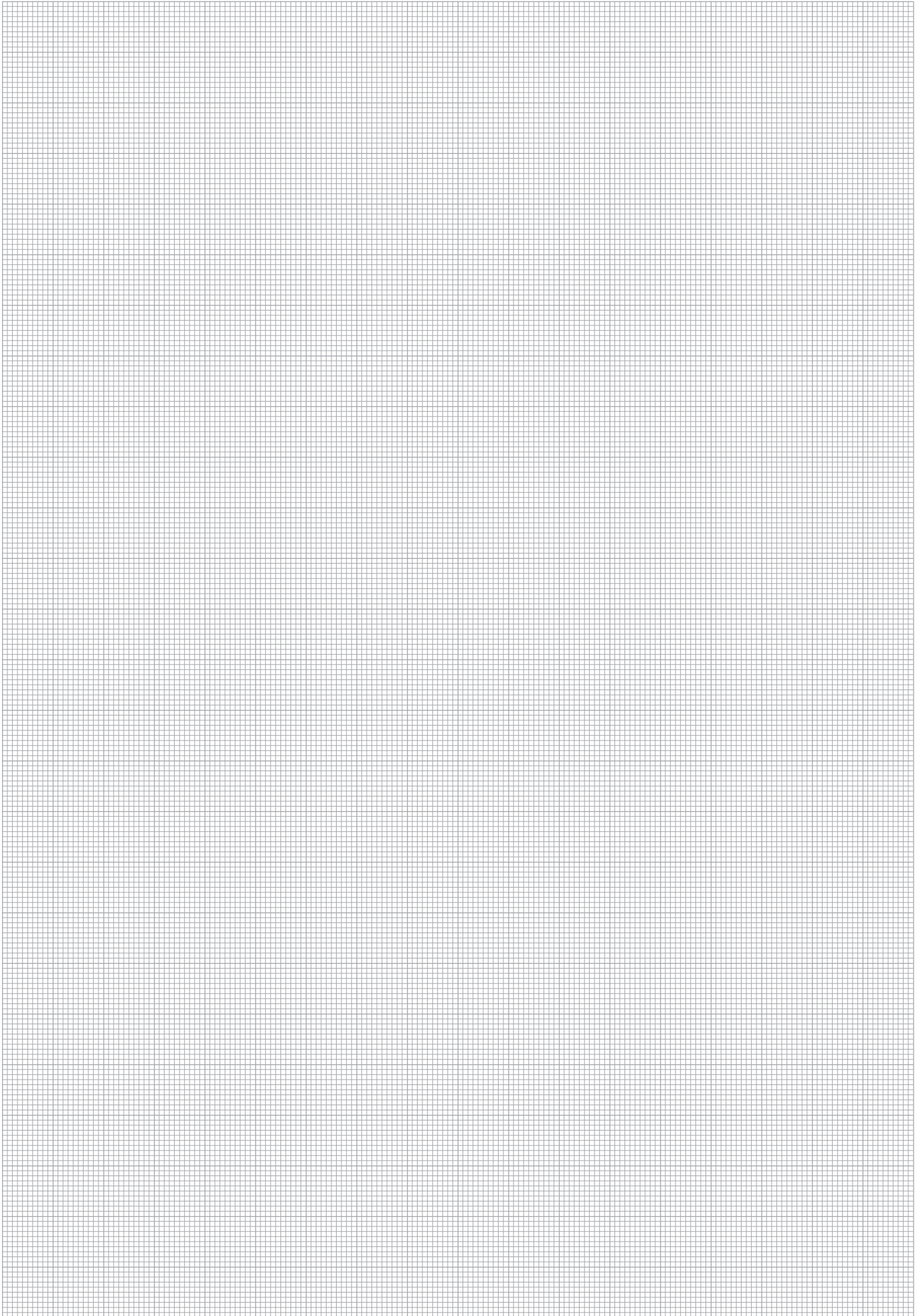





Safety Regulations for Handling of Quick Release Couplings and Accessories

Important !

Incorrect selection or incorrect and inexperienced handling of couplings and accessories may result in property damage or personal injury.

- High velocity fluid discharge
- Explosion or combustion of the conveyed fluid
- Collision with moving or dropping components, caused by failure of a hydraulic circuit
- Dangerous whipping of hydraulic hoses
- Risk of injury through contacting hot, cold or otherwise dangerous fluids

Read and observe the following instructions prior to selecting and using a snap-in coupling or associated accessories.

1 General Notes

1.1 General

This section contains instructions on selection and handling (installation, coupling and uncoupling and maintenance). This is to be understood as additional safety notes and must be taken into consideration in the use and application of the products.

1.2 Safety Measures

Couplings may possibly fail without prior warning. Take this into consideration when planning the safety devices of your system or plant.

1.3 Information for the User

Forward these safety notes to the persons responsible for the selection and handling of couplings. Use only couplings for which you have received and understood product-specific information.

1.4 Responsibility of the User

Due to the versatile range of applications of couplings, not every application case and every technical detail can be dealt with in this document.

The user is responsible for:

- final selection of the product
- fulfilment of requirements by the operator
- safety of operating personnel and plant
- safety measures necessary in the use of couplings

Should you have any further questions, please contact our sales department.

2 Correct Selection of Couplings

2.1 Pressure Range

The coupling to be used must be selected so that the maximum permissible operating pressure is equal to or higher than the system pressure. Pressure peaks in the system in excess of the operating pressure reduce the service life of the couplings and therefore should be taken into consideration when making the selection.

2.2 Resistance to Media

The Sealing Materials in the couplings are suitable for a large variety of pressure media. Information on the compatibility of a particular type of fluid are available upon request from product manager.

2.3 Operating Temperature

The indication of operating temperatures in the technical specifications represents maximum values. These values may not be exceeded in standing or flowing circuits. For actuation the natural warming of the coupling must also be taken into consideration.

2.4 Size

The selection of the size and type of connection depends on the required transmission of forces. For this purpose, refer to the corresponding diagrams. Flow volume, pressure loss and flow speed should be taken into consideration when selecting the correct size of a coupling. Should these values be exceeded, malfunctions within the coupling may occur.

2.5 Mechanical Connection

The connection of the two halves of a coupling is achieved depending on the type. It is important to observe the positive engagement of plug-type couplings and the secure tightening of screw-type couplings to the limit stop of the thread. Forced or improper separation will result in malfunction of the coupling.

2.6 Thermal Stress

Excessive warming of the coupling above the recommended operating temperature, for instance due to welding or soldering, can cause the formation of dangerous gases. In addition, the protective surface finish (galvanization) will be damaged and the function of the coupling may be impaired.

2.7 Guidelines

Applicable specifications, standards and regulations as well as technical rules must be taken into consideration in the selection of couplings.



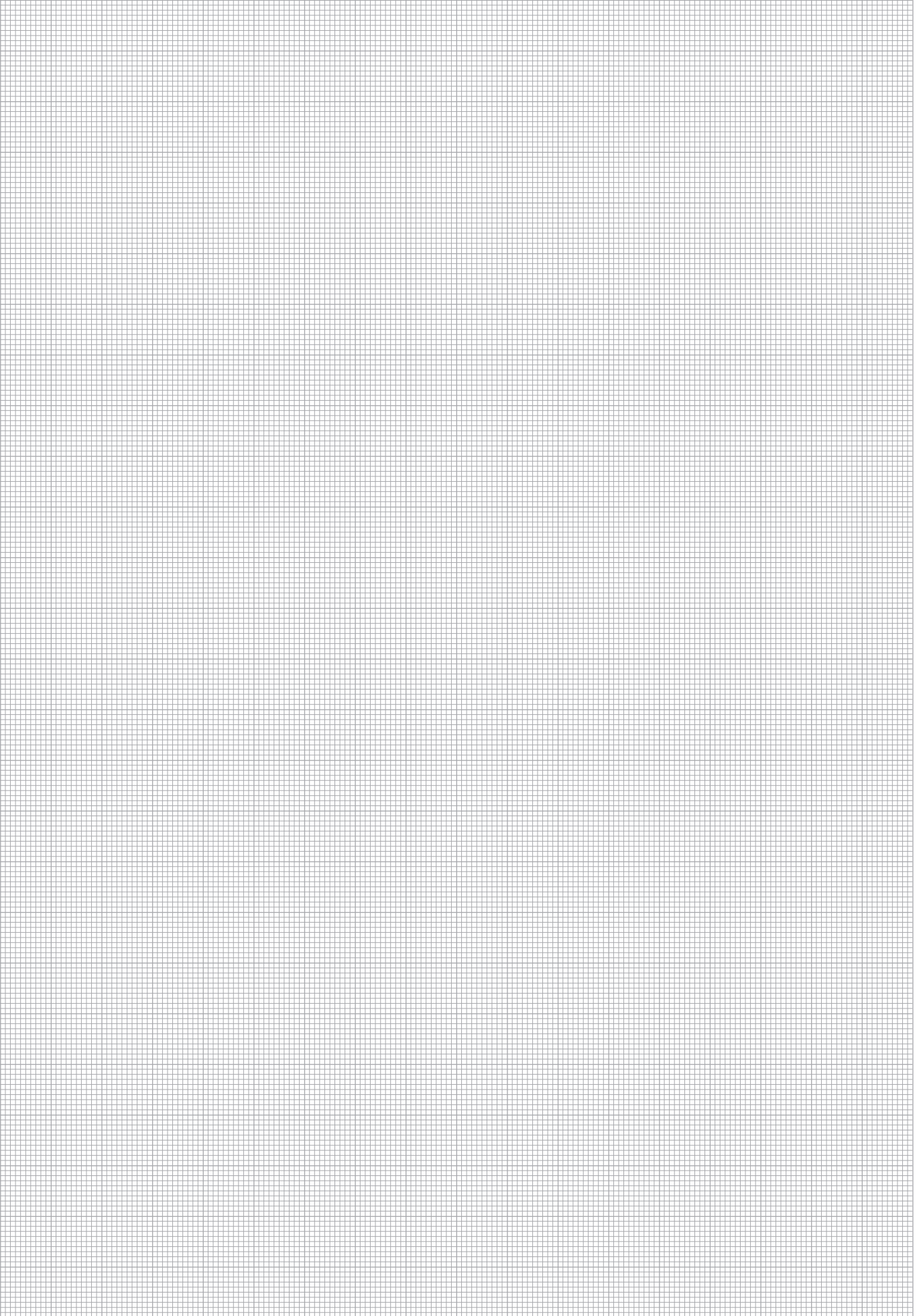



Product-Specific Abbreviations	230 - 233
--------------------------------	-----------

Global Contact Directory	234 - 235
--------------------------	-----------



Product-Specific Abbreviations

Abbreviation	Product Category	Product Description	Page
FF-06	Push-to-Connect Couplings	Series FF-06 ■ BG 1 ■ Nominal Size 6,3	19
FF-10	Push-to-Connect Couplings	Series FF-10 ■ BG 2 ■ Nominal Size 10	20
FF-12	Push-to-Connect Couplings	Series FF-12 ■ BG 3 ■ Nominal Size 12,5	21
FF-16	Push-to-Connect Couplings	Series FF-16 ■ BG 4A ■ Nominal Size 16	22
FF-19	Push-to-Connect Couplings	Series FF-19 ■ BG 4 ■ Nominal Size 19	23
FF-25	Push-to-Connect Couplings	Series FF-25 ■ BG 5 ■ Nominal Size 25	24
FF-38	Push-to-Connect Couplings	Series FF-38 ■ BG 6 ■ Nominal Size 38	25
FH/FU 51	Push-to-Connect Couplings	Series FH/FU 51 ■ BG 7 ■ Nominal Size 51	25
FF ■ Dust Protection	Push-to-Connect Couplings	Series FF ■ Dust Protection	26
FC-10	Push-to-Connect Couplings	Series FC-10 ■ BG 2 ■ Nominal Size 10	31
FC-12	Push-to-Connect Couplings	Series FC-12 ■ BG 3 ■ Nominal Size 12,5	31
FC-16	Push-to-Connect Couplings	Series FC-12 ■ BG 4A ■ Nominal Size 16	32
FC-19	Push-to-Connect Couplings	Series FC-19 ■ BG 4 ■ Nominal Size 19	32
FC-25	Push-to-Connect Couplings	Series FC-19 ■ BG 5 ■ Nominal Size 25	33
FC ■ Dust Protection	Push-to-Connect Couplings	Series FC ■ Dust Protection	34
FH-10 ■ Stainless Steel	Push-to-Connect Couplings	Series FH-10 ■ BG 2 ■ Nominal Size 10	39
FH-12 ■ Stainless Steel	Push-to-Connect Couplings	Series FH-12 ■ BG 3 ■ Nominal Size 12,5	39
FH-19 ■ Stainless Steel	Push-to-Connect Couplings	Series FH-19 ■ BG 4 ■ Nominal Size 19	40
FO-06 ■ Stainless Steel	Push-to-Connect Couplings	Series FO-06 ■ BG 1 ■ Nominal Size 6,3	43
FO-10 ■ Stainless Steel	Push-to-Connect Couplings	Series FO-10 ■ BG 2 ■ Nominal Size 10	43
FO-12 ■ Stainless Steel	Push-to-Connect Couplings	Series FO-12 ■ BG 3 ■ Nominal Size 12,5	43
FO-19 ■ Stainless Steel	Push-to-Connect Couplings	Series FO-19 ■ BG 4 ■ Nominal Size 19	43
FO-25 ■ Stainless Steel	Push-to-Connect Couplings	Series FO-25 ■ BG 5 ■ Nominal Size 25	44
HPA-06	Push-to-Connect Couplings	Series HP-06 ■ BG 1 ■ Nominal Size 6,3	47
HP-10	Push-to-Connect Couplings	Series HP-10 ■ BG 2 ■ Nominal Size 10	48
HPA-10	Push-to-Connect Couplings	Series HP-10A ■ BG 2 ■ Nominal Size 10	49
HP-12	Push-to-Connect Couplings	Series HP-12 ■ BG 3 ■ Nominal Size 12,5	50-51
ZP-12	Push-to-Connect Couplings	Series ZP-12 ■ BG 3 ■ Nominal Size 12,5	52
AP-12	Push-to-Connect Couplings	Series AP-12 ■ BG 3 ■ Nominal Size 12,5	53
HU-12	Push-to-Connect Couplings	Series HU-12 ■ BG 3 ■ Nominal Size 12,5	53
HP-19	Push-to-Connect Couplings	Series HP-19 ■ BG 4 ■ Nominal Size 19	54
HP-25	Push-to-Connect Couplings	Series HP-25 ■ BG 6 ■ Nominal Size 25	55
HP ■ Dust Protection	Push-to-Connect Couplings	Series HP and Series HU ■ Dust Protection	56
UX-12 ■ short version	Push-to-Connect Couplings	Series UX-S-12 ■ BG 3 ■ Nominal Size 12,5 ■ short version	59
UX-12 ■ long version	Push-to-Connect Couplings	Series UX-L-12 ■ BG 3 ■ Nominal Size 12,5 ■ long version	60
IA-06	Push-to-Connect Couplings	Series IA-06 ■ BG 1 ■ Nominal Size 6,3	63
IA-10	Push-to-Connect Couplings	Series IA-10 ■ BG 2 ■ Nominal Size 10	63
IA-12	Push-to-Connect Couplings	Series IA-12 ■ BG 3 ■ Nominal Size 12,5	64
IA-19	Push-to-Connect Couplings	Series IA-19 ■ BG 4 ■ Nominal Size 19	64
IA-25	Push-to-Connect Couplings	Series IA-25 ■ BG 6 ■ Nominal Size 25	65
IA-31	Push-to-Connect Couplings	Series IA-31 ■ BG 7 ■ Nominal Size 31,5	65
IA-38	Push-to-Connect Couplings	Series IA-38 ■ BG 8 ■ Nominal Size 38	65
IA-51	Push-to-Connect Couplings	Series IA-51 ■ BG 9 ■ Nominal Size 51	65
IA ■ Dust Protection	Push-to-Connect Couplings	Series IA ■ Dust Protection	66
IA-06 ■ Stainless Steel	Push-to-Connect Couplings	Series IA-06 ■ BG 1 ■ Nominal Size 6,3	69
IA-10 ■ Stainless Steel	Push-to-Connect Couplings	Series IA-10 ■ BG 2 ■ Nominal Size 10	69
IA-12 ■ Stainless Steel	Push-to-Connect Couplings	Series IA-12 ■ BG 3 ■ Nominal Size 12,5	69
IA-19 ■ Stainless Steel	Push-to-Connect Couplings	Series IA-19 ■ BG 4 ■ Nominal Size 19	69
IA-25 ■ Stainless Steel	Push-to-Connect Couplings	Series IA-25 ■ BG 6 ■ Nominal Size 25	70
IA-31 ■ Stainless Steel	Push-to-Connect Couplings	Series IA-31 ■ BG 7 ■ Nominal Size 31,5	70
IA-38 ■ Stainless Steel	Push-to-Connect Couplings	Series IA-38 ■ BG 8 ■ Nominal Size 38	70
IA-51 ■ Stainless Steel	Push-to-Connect Couplings	Series IA-51 ■ BG 9 ■ Nominal Size 51	70
IA ■ Stainless Steel ■ Dust Protection	Push-to-Connect Couplings	Series IA ■ Dust Protection	71
IB-05	Push-to-Connect Couplings	Series IB-05 ■ BG 0 ■ Nominal Size 3,2	75
IB-06	Push-to-Connect Couplings	Series IB-06 ■ BG 1 ■ Nominal Size 6,3	75
IB-10	Push-to-Connect Couplings	Series IB-10 ■ BG 2 ■ Nominal Size 10	75
IB-12	Push-to-Connect Couplings	Series IB-12 ■ BG 3 ■ Nominal Size 12,5	76
IB-19	Push-to-Connect Couplings	Series IB-19 ■ BG 4 ■ Nominal Size 19	76
IB-25	Push-to-Connect Couplings	Series IB-25 ■ BG 6 ■ Nominal Size 25	76
IB-38	Push-to-Connect Couplings	Series IB-38 ■ BG 8 ■ Nominal Size 38	77
IB-51	Push-to-Connect Couplings	Series IB-51 ■ BG 9 ■ Nominal Size 51	77
IB ■ Dust Protection	Push-to-Connect Couplings	Series IB ■ Dust Protection	78
IB-06 ■ Brass	Push-to-Connect Couplings	Series IB-06 ■ BG 1 ■ Nominal Size 6,3	81
IB-10 ■ Brass	Push-to-Connect Couplings	Series IB-10 ■ BG 2 ■ Nominal Size 10	81
IB-12 ■ Brass	Push-to-Connect Couplings	Series IB-12 ■ BG 3 ■ Nominal Size 12,5	81
IB-19 ■ Brass	Push-to-Connect Couplings	Series IB-19 ■ BG 4 ■ Nominal Size 19	81
IB-25 ■ Brass	Push-to-Connect Couplings	Series IB-25 ■ BG 6 ■ Nominal Size 25	82
IB-38 ■ Brass	Push-to-Connect Couplings	Series IB-38 ■ BG 8 ■ Nominal Size 38	82
IB-51 ■ Brass	Push-to-Connect Couplings	Series IB-51 ■ BG 9 ■ Nominal Size 51	82
IB ■ Brass ■ Dust Protection	Push-to-Connect Couplings	Series IB ■ Dust Protection	83



Product-Specific Abbreviations

Abbreviation	Product Category	Product Description	Page
IB-06 ■ Stainless Steel	Push-to-Connect Couplings	Series IB-06 ■ BG 1 ■ Nominal Size 6,3	87
IB-10 ■ Stainless Steel	Push-to-Connect Couplings	Series IB-10 ■ BG 2 ■ Nominal Size 10	87
IB-12 ■ Stainless Steel	Push-to-Connect Couplings	Series IB-12 ■ BG 3 ■ Nominal Size 12,5	87
IB-19 ■ Stainless Steel	Push-to-Connect Couplings	Series IB-19 ■ BG 4 ■ Nominal Size 19	87
IB-25 ■ Stainless Steel	Push-to-Connect Couplings	Series IB-25 ■ BG 6 ■ Nominal Size 25	88
IB-38 ■ Stainless Steel	Push-to-Connect Couplings	Series IB-38 ■ BG 8 ■ Nominal Size 38	88
IB-51 ■ Stainless Steel	Push-to-Connect Couplings	Series IB-51 ■ BG 9 ■ Nominal Size 51	88
IB ■ Stainless Steel ■ Dust Protection	Push-to-Connect Couplings	Series IB ■ Dust Protection	89
ID-06	Push-to-Connect Couplings	Series ID-06 ■ BG 1 ■ Nominal Size 6,3	93
ID-10	Push-to-Connect Couplings	Series ID-10 ■ BG 2 ■ Nominal Size 10	93
ID-19	Push-to-Connect Couplings	Series ID-19 ■ BG 4 ■ Nominal Size 19	93
ID-25	Push-to-Connect Couplings	Series ID-25 ■ BG 6 ■ Nominal Size 25	93
ID ■ Dust Protection	Push-to-Connect Couplings	Series ID ■ Dust Protection	94
BP-12	Push-to-Connect Couplings	Series BP-12 ■ BG 3 ■ Nominal Size 12,5	97
BP ■ Dust Protection	Push-to-Connect Couplings	Series BP ■ Dust Protection	97
HC-06	Push-to-Connect Couplings	Series HC-06 ■ BG 1 ■ Nominal Size 6,3	101
HC ■ Dust Protection	Push-to-Connect Couplings	Series HC ■ Dust Protection	101
HD-06	Push-to-Connect Couplings	Series HD-06 ■ BG 1 ■ Nominal Size 6,3	105
HD ■ Dust Protection	Push-to-Connect Couplings	Series HD ■ Dust Protection	105
HUS-10	Push-to-Connect Couplings	Series HUS-10 ■ BG 2 ■ Nominal Size 10	109
HUS-12	Push-to-Connect Couplings	Series HUS-12 ■ BG 3 ■ Nominal Size 12,5	109
HUS-19	Push-to-Connect Couplings	Series HUS-19 ■ BG 4 ■ Nominal Size 19	109
HUS-25	Push-to-Connect Couplings	Series HUS-25 ■ BG 6 ■ Nominal Size 25	109
MK-Q-10/4	Multi Couplings	Series MK-Q-10/4 ■ BG 2 ■ Nominal Size 10	113
MK-R-10/4	Multi Couplings	Series MK-R-10/4 ■ BG 2 ■ Nominal Size 10	114
HS-06	Screw-to-Connect Couplings	Series HS-06 ■ BG 1 ■ Nominal Size 6,3	119
HS-10	Screw-to-Connect Couplings	Series HS-10 ■ BG 2 ■ Nominal Size 10	120
HS-12	Screw-to-Connect Couplings	Series HS-12 ■ BG 3 ■ Nominal Size 12,5	121-122
HS-19	Screw-to-Connect Couplings	Series HS-19 ■ BG 4 ■ Nominal Size 19	123
HS-25	Screw-to-Connect Couplings	Series HS-25 ■ BG 6 ■ Nominal Size 25	124
HS-38	Screw-to-Connect Couplings	Series HS-38 ■ BG 8 ■ Nominal Size 38	125-126
HS ■ Dust Protection	Screw-to-Connect Couplings	Series HS ■ Dust Protection	127
HS-06 ■ Stainless Steel	Screw-to-Connect Couplings	Series HS-06 ■ BG 1 ■ Nominal Size 6,3	131
HS-10 ■ Stainless Steel	Screw-to-Connect Couplings	Series HS-10 ■ BG 2 ■ Nominal Size 10	131
HS-12 ■ Stainless Steel	Screw-to-Connect Couplings	Series HS-12 ■ BG 3 ■ Nominal Size 12,5	131
HS-19 ■ Stainless Steel	Screw-to-Connect Couplings	Series HS-19 ■ BG 4 ■ Nominal Size 19	131
HS-25 ■ Stainless Steel	Screw-to-Connect Couplings	Series HS-25 ■ BG 6 ■ Nominal Size 25	132
HS-38 ■ Stainless Steel	Screw-to-Connect Couplings	Series HS-38 ■ BG 8 ■ Nominal Size 38	132
HS ■ Stainless Steel ■ Dust Protection	Screw-to-Connect Couplings	Series HS ■ Dust Protection	133
PS-25	Screw-to-Connect Couplings	Series PS-25 ■ BG 08 ■ Nominal Size 25	137
PS ■ Dust Protection	Screw-to-Connect Couplings	Series PS ■ Dust Protection	137
RH-10	Screw-to-Connect Couplings	Series RH-10 ■ BG 2 ■ Nominal Size 10	141
RH-12	Screw-to-Connect Couplings	Series RH-12 ■ BG 3 ■ Nominal Size 12,5	141
RH-16	Screw-to-Connect Couplings	Series RH-16 ■ BG 4 ■ Nominal Size 16	142
RH-19	Screw-to-Connect Couplings	Series RH-19 ■ BG 6 ■ Nominal Size 19	142
RH-25	Screw-to-Connect Couplings	Series RH-25 ■ BG 8 ■ Nominal Size 25	143
RH ■ Dust Protection	Screw-to-Connect Couplings	Series RH ■ Dust Protection	143
FG-10	Screw-to-Connect Couplings	Series FG-10 ■ BG 2 ■ Nominal Size 10	147
FG-12	Screw-to-Connect Couplings	Series FG-12 ■ BG 3 ■ Nominal Size 12,5	147
FG-16	Screw-to-Connect Couplings	Series FG-16 ■ BG 4A ■ Nominal Size 16	148
FG-19	Screw-to-Connect Couplings	Series FG-19 ■ BG 4 ■ Nominal Size 19	148
FG-25	Screw-to-Connect Couplings	Series FG-25 ■ BG 5 ■ Nominal Size 25	149
FT-31	Screw-to-Connect Couplings	Series FT-31 ■ BG 6 ■ Nominal Size 31,5	149
FG ■ Dust Protection	Screw-to-Connect Couplings	Series FG ■ Dust Protection	150
HR-10	Screw-to-Connect Couplings	Series HR-10 ■ BG 2 ■ Nominal Size 10	153
HR-12	Screw-to-Connect Couplings	Series HR-12 ■ BG 3 ■ Nominal Size 12,5	153
HR-19	Screw-to-Connect Couplings	Series HR-19 ■ BG 4 ■ Nominal Size 19	153
HR-25	Screw-to-Connect Couplings	Series HR-25 ■ BG 6 ■ Nominal Size 25	153
HR-31	Screw-to-Connect Couplings	Series HR-31 ■ BG 8 ■ Nominal Size 31,5	154
HR-38	Screw-to-Connect Couplings	Series HR-38 ■ BG 10 ■ Nominal Size 38	154
HR ■ Dust Protection	Screw-to-Connect Couplings	Series HR ■ Dust Protection	155



Product-Specific Abbreviations

Abbreviation	Product Category	Product Description	Page
HH-10	Screw-to-Connect Couplings	Series HH-10 ▪ BG 2 ▪ Nominal Size 10	159
HH-12	Screw-to-Connect Couplings	Series HH-12 ▪ BG 3 ▪ Nominal Size 12,5	159
HH-19	Screw-to-Connect Couplings	Series HH-19 ▪ BG 4 ▪ Nominal Size 19	159
HH-25	Screw-to-Connect Couplings	Series HH-25 ▪ BG 6 ▪ Nominal Size 25	159
HH-31	Screw-to-Connect Couplings	Series HH-31 ▪ BG 8 ▪ Nominal Size 31,5	160
HH-38	Screw-to-Connect Couplings	Series HH-38 ▪ BG 10 ▪ Nominal Size 38	160
HH-51	Screw-to-Connect Couplings	Series HH-51 ▪ BG 12 ▪ Nominal Size 51	160
HH ▪ Dust Protection	Screw-to-Connect Couplings	Series HH ▪ Dust Protection	161
HH-10 ▪ Stainless Steel	Screw-to-Connect Couplings	Series HH-10 ▪ BG 2 ▪ Nominal Size 10	165
HH-12 ▪ Stainless Steel	Screw-to-Connect Couplings	Series HH-12 ▪ BG 3 ▪ Nominal Size 12,5	165
HH-19 ▪ Stainless Steel	Screw-to-Connect Couplings	Series HH-19 ▪ BG 4 ▪ Nominal Size 19	165
HH-25 ▪ Stainless Steel	Screw-to-Connect Couplings	Series HH-25 ▪ BG 6 ▪ Nominal Size 25	165
HH-31 ▪ Stainless Steel	Screw-to-Connect Couplings	Series HH-31 ▪ BG 8 ▪ Nominal Size 31,5	166
HH-38 ▪ Stainless Steel	Screw-to-Connect Couplings	Series HH-38 ▪ BG 10 ▪ Nominal Size 38	166
HH-51 ▪ Stainless Steel	Screw-to-Connect Couplings	Series HH-51 ▪ BG 12 ▪ Nominal Size 51	166
HH ▪ Stainless Steel ▪ Dust Protection	Screw-to-Connect Couplings	Series HH ▪ Dust Protection	167
HI-06	Screw-to-Connect Couplings	Series HI-06 ▪ BG 1 ▪ Nominal Size 6,3	171
HI-10	Screw-to-Connect Couplings	Series HI-10 ▪ BG 2 ▪ Nominal Size 10	171
HI ▪ Dust Protection	Screw-to-Connect Couplings	Series HI ▪ Dust Protection	172
HT-19	Screw-to-Connect Couplings	Series HT-19 ▪ BG 4 ▪ Nominal Size 19	175
HT-25	Screw-to-Connect Couplings	Series HT-25 ▪ BG 6 ▪ Nominal Size 25	175
HT ▪ Dust Protection	Screw-to-Connect Couplings	Series HT ▪ Dust Protection	175
HM-19	Screw-to-Connect Couplings	Series HM-19 ▪ BG 4 ▪ Nominal Size 19	179
HM-25	Screw-to-Connect Couplings	Series HM-25 ▪ BG 6 ▪ Nominal Size 25	179
HM-31	Screw-to-Connect Couplings	Series HM-31 ▪ BG 8 ▪ Nominal Size 31,5	179
HM-38	Screw-to-Connect Couplings	Series HM-38 ▪ BG 10 ▪ Nominal Size 38	179
HM ▪ Dust Protection	Screw-to-Connect Couplings	Series HM ▪ Dust Protection	180
HV-19	Screw-to-Connect Couplings	Series HV-19 ▪ BG 4 ▪ Nominal Size 19	183
HV-25	Screw-to-Connect Couplings	Series HV-25 ▪ BG 6 ▪ Nominal Size 25	183
HV-31	Screw-to-Connect Couplings	Series HV-31 ▪ BG 8 ▪ Nominal Size 31,5	183
HV-38	Screw-to-Connect Couplings	Series HV-38 ▪ BG 10 ▪ Nominal Size 38	183
HV-51	Screw-to-Connect Couplings	Series HV-51 ▪ BG 12 ▪ Nominal Size 51	184
HV ▪ Dust Protection	Screw-to-Connect Couplings	Series HV ▪ Dust Protection	184



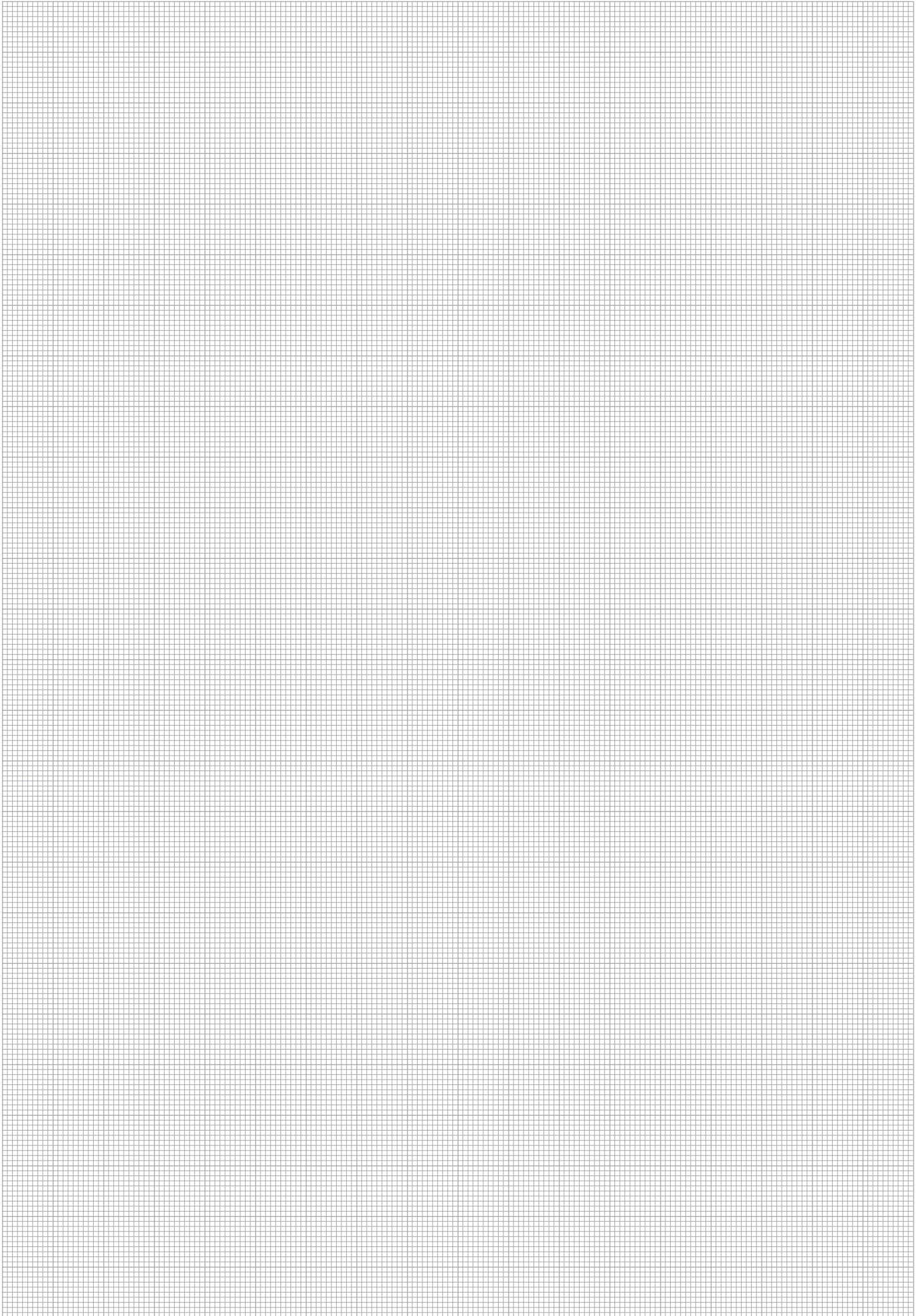

Global Contact Directory

STAUFF products and services are globally available through wholly-owned subsidiaries and a tight network of authorised distributors and representatives in all major industrial regions of the world.

Contact information on this page may be subject to changes and additions over time. Frequently updated and complete contact information can always be found at www.stauff.com.

Germany



Walter Stauffenberg GmbH & Co. KG

Im Ehrenfeld 4
58791 Werdohl
www.stauff.com/contact



Neuenrade-Küntrop Logistics Centre
Wasserburgstraße 35
58809 Neuenrade



Plettenberg-Ohle Production Site
Lennastraße 2
58840 Plettenberg

www.stauff.com



Meinerzhagen Production Site
Neugrünenthal
58540 Meinerzhagen



Meinerzhagen Production Site
Am Rottland 7
58540 Meinerzhagen



STAUFF Digital
Phoenixplatz 3
44263 Dortmund

Europe

France

STAUFF S.A.S.

230, Avenue du Grain d'Or
Z.I. de Vineuil - Blois Sud
41354 Vineuil-cedex
Tel.: +33 2 54 50 55 50
Fax: +33 2 54 42 29 19
E-Mail: direction@stauffsa.com
www.stauff.fr

Ireland

STAUFF UK Ltd.

Block B, 9 Ferguson Drive
Knockmore Hill Industrial Estate
Lisburn, County Antrim, BT28 2EX
Tel.: +44 2892 60 69 00
Fax: +44 2892 60 26 88
E-Mail: sales@stauffireland.com
www.stauff.co.uk

Italy

STAUFF Italia s.r.l

Via Borima 21 (Frazione Borima)
23867 Suello (LC)
Tel.: +39 031 65 84 94
Fax: +39 031 65 50 05
E-Mail: sales@stauff.it
www.stauff.it

Poland

STAUFF Polska Sp. z o.o.

Miszewko 43 A
80-297 Banino
Tel.: +48 58 660 11 60
Fax: +48 58 629 79 52
E-Mail: sales@stauff.pl
www.stauff.pl

Russian Federation

STAUFF LLC

Building 1
19, Leninskaya Sloboda
Moscow, 115280
Tel.: +7 495 276 16 50
Fax: +7 495 276 16 51
E-Mail: sales@stauff.ru
www.stauff.ru

United Kingdom

STAUFF UK Ltd.

500, Carlisle Street East
Off Downgate Drive
Sheffield, S4 8BS
Tel.: +44 114 251 85 18
Fax: +44 114 251 85 19
E-Mail: sales@stauff.co.uk
www.stauff.co.uk

STAUFF UK Ltd.

Badentoy Avenue
Badentoy Industrial Estate
Portlethen, Aberdeen, AB12 4YB
Tel.: +44 1224 78 61 66
Fax: +44 1224 78 61 77
E-Mail: sales@stauffscotland.co.uk
www.stauff.co.uk

Further branch offices in
Engels, Volzhskiy, Magnitogorsk,
Nizhny Novgorod and St. Petersburg.



Global Contact Directory

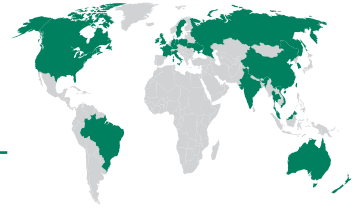

North America

Canada

STAUFF Canada Ltd.
866 Milner Avenue
Scarborough
Ontario M1B 5N7
Tel.: +1 416 282 46 08
Fax: +1 416 282 30 39
E-Mail: sales@stauffcanada.com
www.stauffcanada.com

United States

STAUFF Corporation
7 Wm. Demarest Place
Waldwick, 07463-1542
New Jersey
Tel.: +1 201 444 78 00
Fax: +1 201 444 78 52
E-Mail: sales@stauffusa.com
www.stauffusa.com

Further branch office in
Canton, Michigan.

South America

Brazil

STAUFF Brasil Ltda.
Avenida Gupê 10767
Galpão 2 - Bloco A
Barueri, São Paulo, CEP 06422-120
Tel.: +55 11 47 72 72 00
Fax: +55 11 47 72 72 10
E-Mail: stauff@stauffbrasil.com
www.stauffbrasil.com

Asia

China

STAUFF CHINA
Building 8, No. 1698, Minyi Road
Songjiang District,
Shanghai, 201612
Tel.: +86 21 68 18 70 00
Fax: +86 21 68 18 71 36
E-Mail: info@stauff.com.cn
www.stauff.com.cn

Further branch offices in Beijing,
Changsha, Chengdu, Changchun,
Chongqing, Jinan, Harbin, Guangzhou,
Shenyang, Wuhan, Xian and Xuzhou.

India

STAUFF India Pvt. Ltd.
Gat no. 26/1 & 27, Sanghar Warehousing
Pune - Nagar Road
Lonikand - 412216
Tel.: +91 20 6731 4900
Fax: +91 20 6731 4905
E-Mail: sales@stauffindia.com
www.stauffindia.com

Korea

STAUFF Korea Ltd.
105, Hwajeonsandan 5-ro
Gangseo-gu
Busan, 46739
Tel.: +82 51 266 6666
Fax: +82 51 266 8866
E-Mail: info@stauff.co.kr
www.stauff.co.kr

Singapore

STAUFF (SEA) Pte. Ltd.
128 Joo Seng Road #02-01
Singapore 368356
Tel.: +65 62 44 61 68
E-Mail: sales_sg@stauff.com
www.stauff.com.sg

Thailand

STAUFF (Thailand) Co., Ltd.
10 Soi On-Nut 74/4
Pravet District
Bangkok 10250
Tel.: +66 2 721 73 23 / 24
Fax: +66 2 721 73 35
E-Mail: sales@stauff.co.th
www.stauff.co.th

Vietnam

STAUFF Vietnam Ltd.
8th Floor, Qunimex Building
28 Nguyen Thi Dieu
District 3, Ho Chi Minh City
Tel.: +84 8 3948 10 41 / 42
Fax: +84 8 3948 10 44
E-Mail: sales@stauff.com.vn
www.stauff.com.vn

Oceania

Australia

STAUFF Corporation Pty Ltd
24-26 Doyle Avenue
UnUnderra NSW 2526
Tel.: +61 2 4271 9000
Fax: +61 2 4271 8432
E-Mail: sales@stauff.com.au
www.stauff.com.au

Further branch offices in
Adelaide, Brisbane, Melbourne
and Sydney.

New Zealand

STAUFF Corporation (NZ) Ltd.
Unit D, 103 Harris Road
East Tamaki, Auckland 2013
Tel.: +64 9 912 1530
Fax: +64 9 912 1531
E-Mail: sales@stauff.co.nz
www.stauff.co.nz



Introduction

Overview

Push-to-Connect Couplings • FF/FU Series

Push-to-Connect Couplings • FH Series

Push-to-Connect Couplings • FO Series

Push-to-Connect Couplings • HP/HU Series

Push-to-Connect Couplings • UX Series

Push-to-Connect Couplings • IA Series

Push-to-Connect Couplings • IB Series

Push-to-Connect Couplings • ID Series

Push-to-Connect Couplings • BP Series

Push-to-Connect Couplings • HC Series

Push-to-Connect Couplings • HD Series

Push-to-Connect Couplings • HUS Series

Multi Couplings • MK Series

Screw-to-Connect Couplings • HS Series

Screw-to-Connect Couplings • PS Series

Screw-to-Connect Couplings • RH Series

Screw-to-Connect Couplings • FT Series

Screw-to-Connect Couplings • HR Series

Screw-to-Connect Couplings • HH Series

Screw-to-Connect Couplings • HI Series

Screw-to-Connect Couplings • HT Series

Screw-to-Connect Couplings • HM Series

Screw-to-Connect Couplings • HV Series

Special Applications

Spare Parts / Accessories

Technical Appendix

Appendix



Catalogue 5

STAUFF Quick Release Couplings

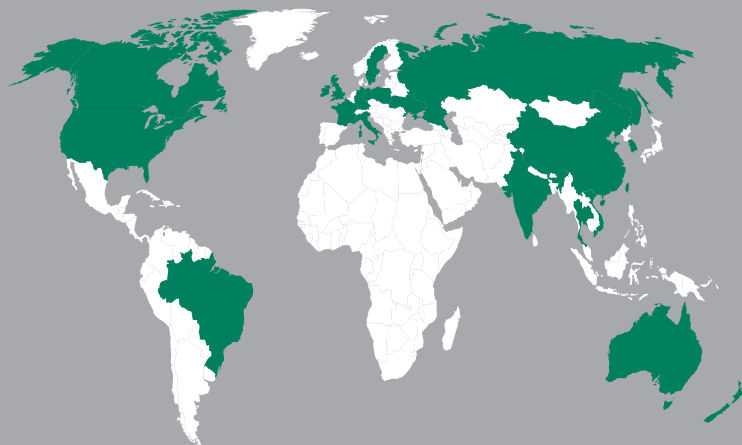

Germany

Walter Stauffenberg GmbH & Co. KG
Im Ehrenfeld 4
58791 Werdohl

STAUFF products and services are globally available through wholly-owned subsidiaries and a tight network of authorised distributors and representatives in all major industrial regions of the world.

Contact STAUFF:

www.stauff.com/contact