



STAUFF Diagtronics

Devices for determining and monitoring
the key parameters in hydraulics

Product Catalogue

Germany

Walter Stauffenberg GmbH & Co. KG

Im Ehrenfeld 4
58791 Werdohl

www.stauff.com

STAUFF products and services are globally available through wholly-owned subsidiaries and a tight network of authorised distributors and representatives in all major industrial regions of the world.

You can find detailed contact information on the last two pages of this product catalogue or at www.stauff.com/contact.

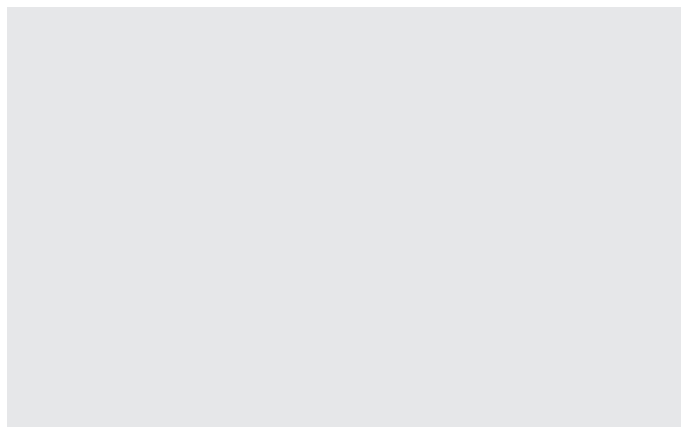
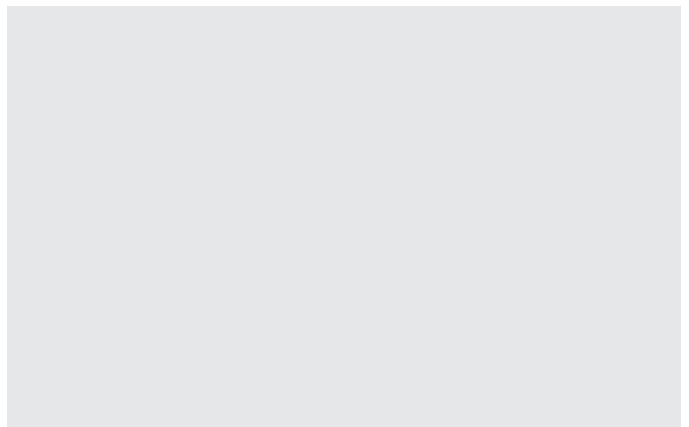
Please note: Unless otherwise stated, all data and figures in this product catalogue are approximate values and are only valid as references, which are not binding (also in respect to any third parties' rights of protection) and thus do not release the customer / user from checking and testing the suitability of the products for the foreseen purposes. Therefore, data and figures can only be used in a limited sense for construction purposes.

The application of the products is beyond the control possibilities of the manufacturer and, therefore, is exclusively subject to the responsibility of the customer / user.

In the event that a liability is nevertheless considered, any compensation will be limited to the value of the goods supplied by the manufacturer and used by the customer / user. As a matter of course, the manufacturer guarantees the perfect quality of all products in accordance with the General Terms and Conditions of Business and Sale.

Subject to modifications due to the ongoing development and improvement of the products.

With the publication of this product catalogue, previous editions are no longer valid.



Introduction	4 - 11	
Pressure Gauges	12 - 21	A
Hydraulic Testers	22 - 63	B
Oil Analysis Equipment	64 - 83	C
Appendix (Product-Specific Abbreviations)	84 - 87	



Catalogue 1 STAUFF Clamps

- Block Clamps
- Special Clamps
- Light Series Clamps
- Saddle Clamps
- U-Bolt Clamps
- Metal Clamps
- Construction Series



Catalogue 2 STAUFF Connect

- Tube Connectors
- Assembly Tools and Devices



Catalogue 3 STAUFF Flanges

- SAE Flanges
- Gear Pump Flanges



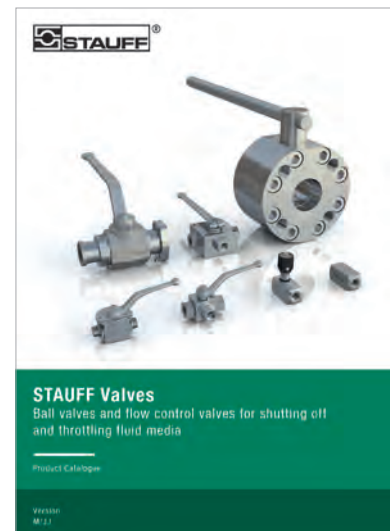
Catalogue 4 STAUFF Hose Connectors

- Hose Connectors
- High-Pressure Hose Connectors



Catalogue 5 STAUFF Quick Release Couplings

- Push-to-Connect Couplings
- Multi Couplings
- Screw-to-Connect Couplings



Catalogue 6 STAUFF Valves

- Two-Way Ball Valves
- Multi-Way Ball Valves
- Flow Control and Check Valves
- Gauge Isolator Valves



Catalogue 7
STAUFF Test

- Test Couplings
- Test Adaptors
- Test Hoses and Connectors



Catalogue 8
STAUFF Diagtronics

- Pressure Gauges
- Hydraulic Testers
- Oil Analysis Equipment



Catalogue 9
STAUFF Filtration Technology

- Replacement Filter Elements
- Pressure Filters
- Return-Line Filters
- In-Line Filters
- Spin-On Filters
- Offline and Bypass Filters
- Filtration Systems



Catalogue 10
STAUFF Hydraulic Accessories

- Fluid Level and Temperature Indicators
- Tank Filler Breathers
- Giant and Desiccant Air Breathers
- Suction Strainers
- Diffusors

For more than 50 years, the companies of STAUFF Group have been developing, manufacturing and distributing pipework equipment and hydraulic components for mechanical and plant engineering and for service and industrial maintenance.

In addition to mobile and industrial hydraulic machinery, typical applications also include commercial and special purpose vehicles, rail transportation and energy technology. Likewise, STAUFF products are used in marine, oil and gas applications and in the process, food and chemical industries.

The overall range currently includes about 50000 standard products as well as numerous special and system solutions according to customer's specifications or based on our in-house development.

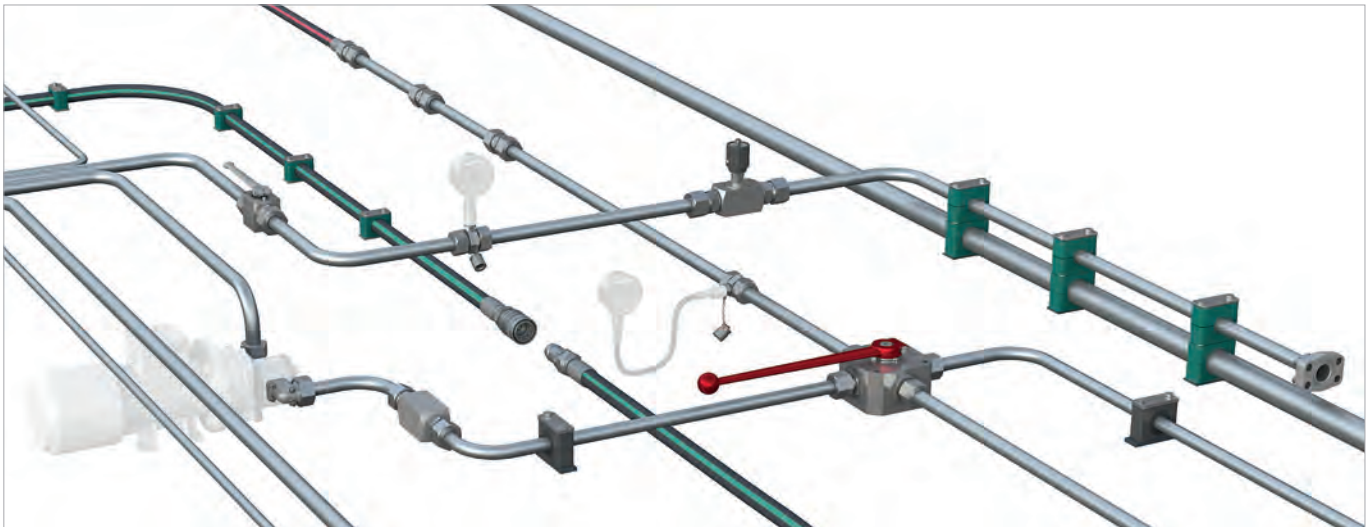
All STAUFF products undergo relevant testing in accordance with international regulations and are governed by the high standards of the in-house quality management system. Furthermore, many items have received certifications and approvals from various international institutes, organisations and authorities who have independently confirmed the quality and performance of the products.

Wholly-owned manufacturing, sales and service facilities in 18 countries and a tight global network of authorised distribution partners ensure high presence and service paired with a maximum of availability.



Quality Management – ISO 9001:2015
Environmental Management – ISO 14001:2015
Safety Management – ISO 45001:2018
Energy Management – ISO 50001:2018

STAUFF LINE Components



With the seven dedicated **STAUFF Line** product groups

- **STAUFF Clamps**
- **STAUFF Connect**
- **STAUFF Flanges**
- **STAUFF Hose Connectors**
- **STAUFF Quick Release Couplings**
- **STAUFF Valves**
- **STAUFF Test**

from own, in-house development and manufacturing, the companies of the STAUFF Group provide a comprehensive range of components for fastening and connecting pipes, tubes and hoses for mobile and industrial hydraulic applications and many other industries.

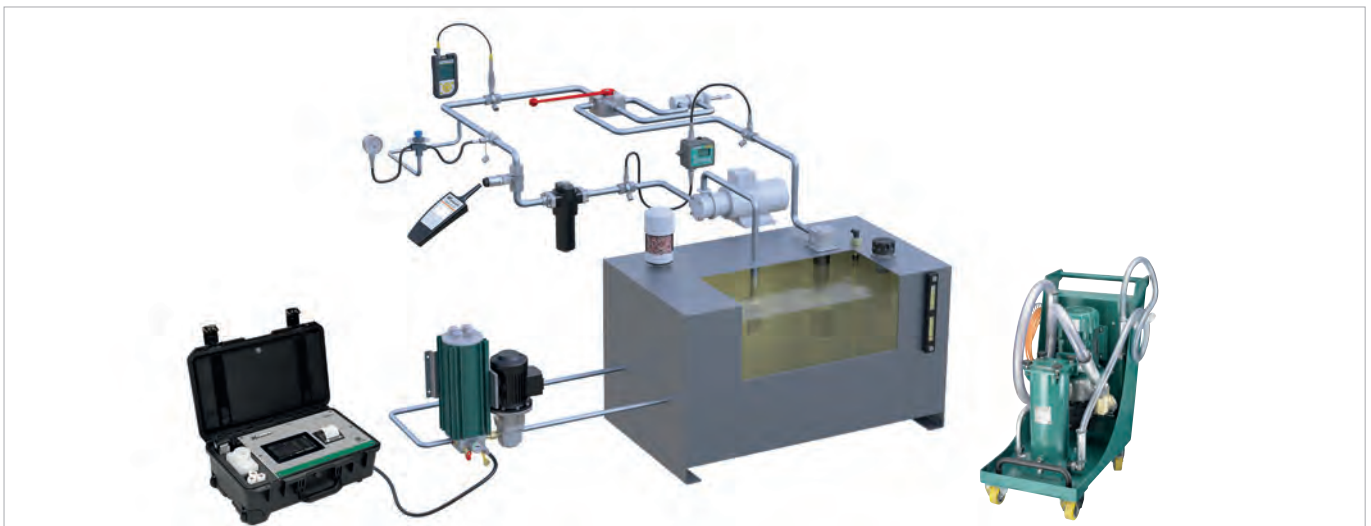
The portfolio is completed by components for shutting-off, regulating, throttling and measuring fluid media.

In order to perfectly match each other, STAUFF Line products are designed and offered on a high, uniform level of quality. A large proportion of the range made from steel comes as standard with the premium STAUFF Zinc/Nickel surface coating, which is also optionally available for many of the other components.

This coating offers the most reliable surface protection far beyond the previous market standards – even after transport, handling and assembly of the components – and meets all current legal requirements.

If desired, Original Equipment Manufacturers can be supported with value-added services, from **technical consultation to pre-assembly, assembly and kitting** as well as **logistics services**:

- Support with the **selection of suitable standard components** and ordering options; provision of **customised solutions** according to customer's specifications or based on our in-house development – from prototyping to large scale production
- **Analysis and optimization** of existing and design and developments of new systems aimed at increasing the efficiency and performance of machines and equipment and creating value for customers by reducing the total cost
- **Pre-assembly, assembly and kitting** of individual components to customer-specific system modules
- Individually coordinated **procurement solutions** (e.g. web shop and electronic data interchange) and **supply models** (e.g. from warehousing of customised components to Kanban logistics and just-in-time delivery of pre-fabricated system modules to the assembly lines of the customers) aimed at optimising material flows



Aligned with the needs of the market, the product groups

- **STAUFF Test**
- **STAUFF Diagtronics**
- **STAUFF Filtration Technology**
- **STAUFF Hydraulic Accessories**

include a comprehensive range of analogue and digital measuring equipment and devices, filtration systems and replacement filter elements as well as accessories for the construction of tanks, reservoirs, power packs and gear boxes in mobile and industrial hydraulics.

The offer is completed by relevant value-added services:

- Support with the **selection of suitable components** and ordering options; provision of **customised solutions** according to customer's specifications or based on our in-house development – from prototyping to large scale production
- Analysis of existing hydraulic circuits aimed at filtration systems, tank components and monitoring devices that perfectly match to the specific requirements, and developing integrated concepts to increase the efficiency and performance of machines and equipment
- Individually coordinated **procurement solutions** and **supply models**



STAUFF Diagtronics

With measuring, testing, display and analysis devices and equipment from the STAUFF Diagtronics product range, system operators, maintenance personnel and repair technicians can determine and monitor the essential parameters in mobile and industrial hydraulics: operating pressure, maximum pressure, differential pressure, system temperature, volume flow, contamination and much more.

The range includes analogue and digital pressure gauges, that are either supplied individually or as part of practical pressure test kits including the required connection adaptors and accessories, as well as high-performance hand-held hydraulic testers of the PPC series, that have been developed to meet the growing demands of the industry.

The PT-RF series of pressure transmitters and readers are an alternative solution for universal pressure measurements for fluid technology applications. The advantages resulting from the use of the non-contact RFID technology for system operators, maintenance personnel and repair technicians are clear: Measurements can be carried very easily, without extensive training and within a few seconds at the press of a button and then documented in a reliable process – while temporary opening of the system if not required. Potential hazards for people, machines and the environment as well as ingress of contamination into the system can be effectively excluded.

Fluid analysis is a crucial element of any oil management program. Early detection of system contamination can prevent costly repairs and downtime.

Mobile and stationary STAUFF particle counters and monitors enable the precise determination of cleanliness levels of hydraulic media according to international standards.





www.stauff.com

With the STAUFF Digital Platform available at www.stauff.com, commercial customers and users of STAUFF products can not only inform themselves in all detail about the 50000 components typically available from stock, but also directly purchase these online without complex registration.

General information about the companies of STAUFF Group, latest business and product news as well as complete global contact details also be available.

www.stauff.com/cad

Immediate access to and free download of 3D models and 2D drawings for a growing number of STAUFF products

Main Functionalities of the STAUFF Digital Platform:

- Around the clock**
Check stock availability and pricing for STAUFF products in real time
- Cross references**
Search by article designations of other manufacturers / suppliers
- Live chat**
Get directly in touch with the STAUFF customer service and sales team
- CAD database**
Download 3D models and 2D drawings for STAUFF products

Advantages as a Registered User of the STAUFF Digital Platform:

- Purchase STAUFF products**
Taking customer-specific pricing and delivery conditions into account
- Ordering w/o searching**
Quick ordering by entering article number, quantity and requested delivery date
- File upload**
Direct upload of orders with multiple positions in CSV or Excel file format
- Notepad function**
Create project lists to save interesting products for later

www.filterinterchange.com





Online database for the quick and easy identification and interchange of almost all common brands and types of replacement filter elements

Follow STAUFF and keep yourself updated:

LinkedIn
www.linkedin.com/company/stauff

Youtube
www.youtube.com/stauffgroup

STAUFF Newsletters
Automatic e-mail notifications about latest news from STAUFF
www.stauff.com/newsletter

	Introduction	14
	Information on the Pressure Equipment Directive	15
	Accessories for Pressure Gauges	15
	Pressure Gauges	16 - 21
	Analogue Pressure Gauge	16
	SPG	
	Analogue Pressure Test Kit	18
	SMB-20 / SMB-15	
	Digital Pressure Gauge	20
	SPG-DIGI / SPG-DIGI-USB	
	Digital Pressure Test Kit	21
	SMB-DIGI / SMB-DIGI-USB	

Pressure Gauges (analogue/digital) and Accessories

A



Measuring pressure on equipment is indispensable for monitoring and ensuring the smooth functioning and operating safety of these systems.

STAUFF offers a variety of simple pressure measuring devices for liquid and gaseous media. These pressure gauges can be used as both stationary or portable devices. STAUFF addresses the very extensive width of possible system pressures and the strict requirements for precision with a variety of pressure gauge types with different measuring ranges.

The glycerine filled gauge range is available with various connection ports to fit many different installation needs. The pressure gauges can be purchased alone or in a test kit. The kits can be supplied with gauges with different pressure ranges and adaptors to satisfy any requirement.

The analog pressure gauges are primarily designed for permanent installations. STAUFF also offers a digital line for analytical troubleshooting.

These digital pressure gauges are also available as a pressure test kit and also make it possible to perform the many different measurement tasks with the help of adaptors and the measuring hose. An important advantage is the possibility to measure pressure peaks with the device, to save them short term and to display them in the display as MIN and MAX values.

In addition to the individual products, the STAUFF measuring devices are also available as kit.

Information on the Pressure Equipment Directive (PED) 97/23/EC Pressure Equipment Directive (PED)

Our pressure gauges (SPG) conform to the European Standard EN 837-1 and are manufactured and tested according to appropriate requirements. Pressure gauges with a full scale value between 0,5 bar and 200 bar / 7.25 PSI and 2900 PSI come under „Good Engineering Practice“ and must not carry a CE mark (section 3, paragraph 3).

Pressure gauges (SPG) with a full scale value of less than 0,5 bar / 7.25 PSI and loose diaphragm sealings do not come under the PED and must not carry a CE mark. Our pressure gauges (SPG) with a full scale value of > 200 bar / 2900 PSI receive a CE mark according to the conformity procedure.

The CE mark is attached to the outside of the housing (type designation plate).
We are not authorised to CE mark pressure gauges without a company name or a company logo.


A

Pressure Gauges ▀ Accessories



Single Station Gauge Isolator Valve
(see Catalogue 6 - STAUFF Valves)



Multi Station Gauge Isolator Valve
(see Catalogue 6 - STAUFF Valves)



Gauge Isolator Needle Valves
(see Catalogue 6 - STAUFF Valves)



Test Hoses - Gauge Adaptor
(see Catalogue 7 - STAUFF Test)



Gauge Adaptor
(see Catalogue 7 - STAUFF Test)



Direct Gauge Adaptor
(see Catalogue 7 - STAUFF Test)



Adjustable Gauge Fitting
(see Catalogue 7 - STAUFF Test)

Pressure Gauge (analogue) - Type SPG

A



Pressure Gauge (Analogue) Type SPG (Stem Mounting)



Pressure Gauge (Analogue) Type SPG (Panel Mounting)

Product Description

Area of Application

- Mechanical pressure measurement

Features

- Suitable for hydraulic oil and gaseous media compatible with copper based alloys
- Available in nominal sizes 63 and 100 mm / 2.5 and 4 in
- Thread form: for BSP (G1/4 and G1/2), NPT (1/4 NPT and 1/2 NPT), SAE (7/16–20 UNF)
- Stainless Steel (1.4301) housing
- Acrylic sight glass
- Glycerine filled
- Standard dual scales with pressure indication in bar and PSI
- U-bolt or flange mounting kit on request

Note: Please contact STAUFF before you use SPG with other media.

Options

- Protective rubber cap
- Additional scale readings including personalisation
- U-bolt and flange mounting kits are available separately as spare parts

Technical Data

- Pressure gauge according to EN 837-1
- Subject to technical modifications

Accuracies

SPG-063:	1.6 (± 1.6 % FS* as per EN 837-1)
SPG-100:	1.0 (± 1.0 % FS* as per EN 837-1)

Note: Accuracy data according to EN 837-1, vertical adjustment position

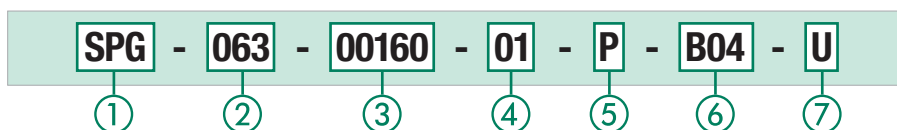
Permissible Temperatures

- Ambient: -20 °C ... +60 °C / -4 °F ... +140 °F
- Media: max. +60 °C / max. +140 °F

Protection Ratings

- IP 65: for all manometer SPG-100 and SPG-063 > 16 bar / 232 PSI
IP 65 protection rating: Dust tight and protected against water jets
- IP 54: for all manometer SPG-063 ≤ 16 bar / 232 PSI due to pressure compensation opening
IP 54 protection rating: Dust protected and protected against splashing water

Order Codes



① Series and Type

Stainless Steel Pressure Gauge **SPG**

② Size

Ø 63 mm, with G1/4 or 1/4 NPT connection **063**
Ø 100 mm, with G1/2 or 1/2 NPT connection **100**

③ Pressure Ranges

Pressure Ranges for style of scale 01 - bar/PSI	Code	Pressure Ranges for style of scale 05 - PSI/bar	Code
-1 ... 1,5 bar / -14,5 ... 21 PSI	(-00001)-00001.5	-1,02 ... 0 bar / -30 inHg ... 0 PSI	30HG30
-1 ... 3 bar / -14,5 ... 43 PSI	(-00001)-00003	-1,02 ... 2,07 bar / -30 inHg ... 30 PSI	03030
0 ... 10 bar / 0 ... 145 PSI	00010	0 ... 2,07 bar / 0 ... 30 PSI	00030
0 ... 16 bar / 0 ... 232 PSI	00016	0 ... 4,14 bar / 0 ... 60 PSI	00060
0 ... 25 bar / 0 ... 362 PSI	00025	0 ... 6,89 bar / 0 ... 100 PSI	00100
0 ... 40 bar / 0 ... 580 PSI	00040	0 ... 11,03 bar / 0 ... 160 PSI	00160
0 ... 60 bar / 0 ... 870 PSI	00060	0 ... 13,79 bar / 0 ... 200 PSI	00200
0 ... 100 bar / 0 ... 1450 PSI	00100	0 ... 20,68 bar / 0 ... 300 PSI	00300
0 ... 160 bar / 0 ... 2320 PSI	00160	0 ... 34,74 bar / 0 ... 500 PSI	00500
0 ... 250 bar / 0 ... 3625 PSI	00250	0 ... 41,37 bar / 0 ... 600 PSI	00600
0 ... 400 bar / 0 ... 5801 PSI	00400	0 ... 68,95 bar / 0 ... 1000 PSI	01000
0 ... 600 bar / 0 ... 8702 PSI	00600	0 ... 103,42 bar / 0 ... 1500 PSI	01500
0 ... 680 bar / 0 ... 9862 PSI	00680	0 ... 137,90 bar / 0 ... 2000 PSI	02000
0 ... 700 bar / 0 ... 10152 PSI	00700	0 ... 206,84 bar / 0 ... 3000 PSI	03000
0 ... 1000 bar / 0 ... 14503 PSI	01000	0 ... 275,79 bar / 0 ... 4000 PSI	04000
		0 ... 344,74 bar / 0 ... 5000 PSI	05000
		0 ... 413,69 bar / 0 ... 6000 PSI	06000
		0 ... 517,11 bar / 0 ... 7500 PSI	07500
		0 ... 689,48 bar / 0 ... 10000 PSI	10000

Note: Others on request. Information always refer to the pressure setting of the outside scale.

④ Styles of Scales

bar / PSI (bar outside / PSI inside - standard option Europe)	01
bar	02
PSI	03
PSI / bar (PSI outside / bar inside - standard option North America)	05
kPa / PSI (kPa outside / PSI inside)	10

Note: Others on request.

⑤ Adaption

Stem mounting	S
Panel mounting	P

⑥ Process Connection

G1/4 (only SPG-063)	B04
G1/2 (only SPG-100)	B08
1/4 NPT (only SPG-063)	N04
1/2 NPT (only SPG-100)	N08
7/16–20 UNF (only SPG-063)	U04

Note: Others on request.

⑦ Accessories

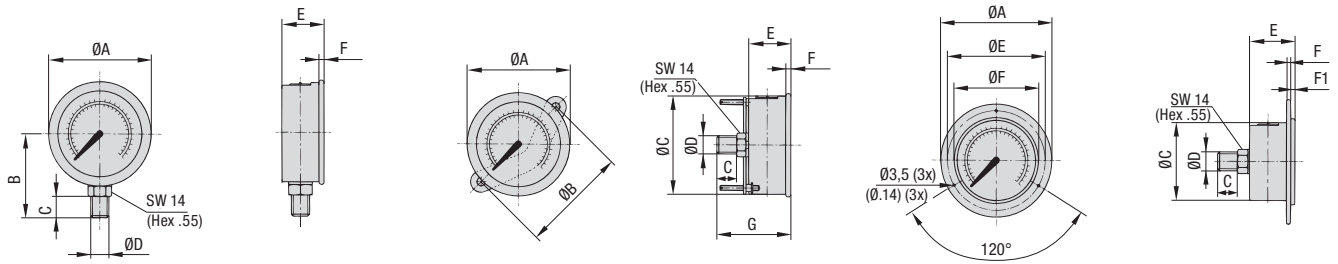
No accessory	(none)
U-bolt assembly	U
Front flange assembly (for panel mount only)	F
Rear flange assembly	R
U-bolt and front flange assembly (for panel mount only)	UF
Protective rubber cap (for stem mount only)	G

For further information see Catalogue 7 - STAUFF Test.

* FS = Full Scale

Pressure Gauge (analogue) ▪ Type SPG

A



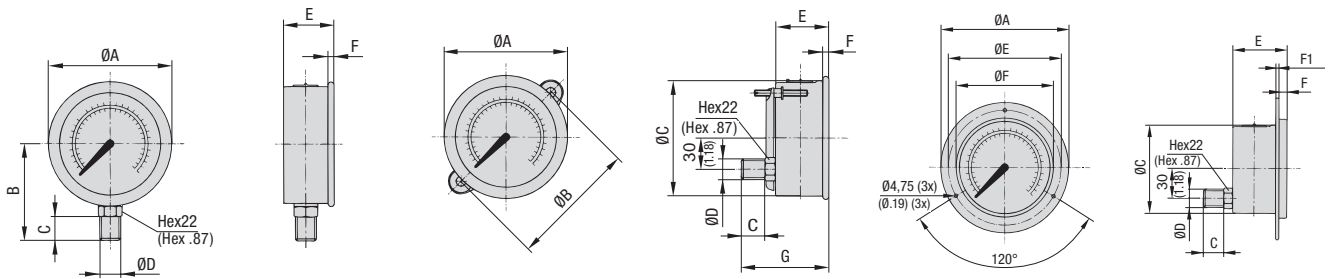
SPG-063 ... S ...

SPG-063 ... P ... U

SPG-063 ... P ... F

Dimensions SPG-063

Version Pressure Gauge	Dimension (mm/in)											
	ØA	ØB	ØC	ØD	ØE	ØF	B	C	E	F	F1	G
SPG-063	69	-	-	G1/4	-	-	54	15	32	6,5	-	-
	2.72	-	-	1/4 NPT	-	-	2.13	.59	1.26	.26	-	-
				7/16-20 UNF								
SPG-063 ... U	69	72	62	G1/4	-	-	-	15	32	6,5	-	56
	2.72	2.83	2.44	1/4 NPT	-	-	-	.59	1.26	.26	-	2.20
				7/16-20 UNF								
SPG-063 ... F	85	-	62	G1/4	75	68	-	15	32	1	6,5	-
	3.35	-	2.44	1/4 NPT	2.95	2.68	-	.59	1.26	.04	.26	-
				7/16-20 UNF								



SPG-100 ... S ...

SPG-100 ... P ... U

SPG-100 ... P ... F

Dimensions SPG-100

Version Pressure Gauge	Dimension (mm/in)											
	ØA	ØB	ØC	ØD	ØE	ØF	B	C	E	F	F1	G
SPG-100	107	-	-	G1/2	-	-	87	23	48	8	-	-
	4.21	-	-	1/2 NPT	-	-	3.43	.91	1.89	.31	-	-
SPG-100 ... U	107	107	100	G1/2	-	-	-	23	48	8	-	81,5
	4.21	4.21	3.94	1/2 NPT	-	-	-	.91	1.89	.31	-	3.21
SPG-100 ... F	132	-	100	G1/2	116	107	-	23	48	8	1,25	-
	5.20	-	3.94	1/2 NPT	4.57	4.21	-	.91	1.89	.31	.05	-

* FS = Full Scale

Dimensional drawings: All dimensions in mm (in).

Pressure Test Kit (analogue) ▪ Type SMB-20 / SMB-15

A



Pressure test kit (analogue) with SPG-063 (3x) Pressure test kit (analogue) with SPG-100 (1x)

Product Description

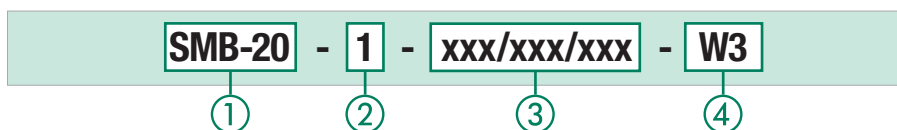
In addition to the individual SPG gauges, the STAUFF Pressure Gauges are also available as part of a pressure test kit.

The SMB Pressure Test Kits are assembled in various versions, in accordance with customer wishes. All pressure test kits are supplied in a handy case with custom-designed foam inserts.

Custom kits available upon request. Please contact STAUFF.

Please see on page 19 for standard options.

Order Codes



① Series and Type

Pressure Test Kit, analogue (STAUFF Test 20)	SMB-20
Pressure Test Kit, analogue (STAUFF Test 15)	SMB-15

② Number of Pressure Gauges

1 pressure gauge SPG-063	1
2 pressure gauges SPG-063	2
3 pressure gauges SPG-063	3
1 pressure gauge SPG-100	/100-1

③ Pressure Ranges

-1 ... 3 bar / -14.5 ... 43 PSI	(-1)-003
0 ... 10 bar / 0 ... 145 PSI	010
0 ... 16 bar / 0 ... 232 PSI	016
0 ... 25 bar / 0 ... 362 PSI	025
0 ... 40 bar / 0 ... 580 PSI	040
0 ... 60 bar / 0 ... 870 PSI	060
0 ... 100 bar / 0 ... 1450 PSI	100
0 ... 160 bar / 0 ... 2320 PSI	160
0 ... 250 bar / 0 ... 3625 PSI	250
0 ... 400 bar / 0 ... 5801 PSI	400
0 ... 600 bar / 0 ... 8702 PSI	600

Note: Please indicate pressure ranges in bar.
 For one pressure gauge please replace xxx.
 For two pressure gauges please replace xxx/xxx.
 For three pressure gauges please replace xxx/xxx/xxx.

④ Material Surface

Steel, zinc/nickel plated	W3
---------------------------	-----------

For further information see Catalogue 7 - STAUFF Test.

Standard Option for Pressure Test Kits (analogue) ▪ Type SMB-20 / SMB-15

Series	Components	Order Codes	Series	Components	Order Codes
SMB-20-1-xxx-W3	1x Test hose (2000 mm length)	SMS-20-2000-B-W3	SMB-15-1-xxx-W3	1x Test hose (2000 mm length)	SMS-15-2000-B-W3
	1x Pressure gauge Ø 63 mm	SPG-063-xxx-...		1x Pressure gauge Ø 63 mm	SPG-063-xxx-...
	1x Gauge adaptor G1/4	SMA-20-G1/4-B-OR-W3		1x Gauge adaptor G1/4	SMA-15-G1/4-B-OR-W3
	1x Direct gauge adaptor G1/4	SMD-20-G1/4-B-OR-W3		1x Direct gauge adaptor G1/4	SMD-15-G1/4-B-OR-W3
	1x Test coupling G1/4	SMK-20-G1/4-B-C-W3		1x Test coupling G1/4	SMK-15-G1/4-B-B-W3
	1x Test coupling M10 x 1	SMK-20-M10x1-B-A-W3		1x Test coupling M14 x 1,5	SMK-15-M14x1.5-B-B-W3
	1x Thread adaptor G3/8	SRS-20-G3/8-B-W3		1x Thread adaptor G3/8	SRS-15-G3/8-B-W3
	1x Thread adaptor G1/2	SRS-20-G1/2-B-W3		1x Thread adaptor G1/2	SRS-15-G1/2-B-W3

xxx/xxx/xxx = pressure ranges see on page 18 (please indicate pressure ranges in bar)
Custom kits available upon request. Please contact STAUFF.

Series	Components	Order Codes	Series	Components	Order Codes
SMB-20-2-xxx/xxx-W3	1x Test hose (2000 mm length)	SMS-20-2000-B-W3	SMB-15-2-xxx/xxx-W3	1x Test hose (2000 mm length)	SMS-15-2000-B-W3
	2x Pressure gauges Ø 63 mm	SPG-063-xxx-...		2x Pressure gauges Ø 63 mm	SPG-063-xxx-...
	1x Gauge adaptor G1/4	SMA-20-G1/4-B-OR-W3		1x Gauge adaptor G1/4	SMA-15-G1/4-B-OR-W3
	1x Direct gauge adaptor G1/4	SMD-20-G1/4-B-OR-W3		1x Direct gauge adaptor G1/4	SMD-15-G1/4-B-OR-W3
	1x Test coupling G1/4	SMK-20-G1/4-B-C-W3		1x Test coupling G1/4	SMK-15-G1/4-B-B-W3
	1x Test coupling M10 x 1	SMK-20-M10x1-B-A-W3		1x Test coupling M14 x 1,5	SMK-15-M14x1.5-B-B-W3
	1x Thread adaptor G3/8	SRS-20-G3/8-B-W3		1x Thread adaptor G3/8	SRS-15-G3/8-B-W3
	1x Thread adaptor G1/2	SRS-20-G1/2-B-W3		1x Thread adaptor G1/2	SRS-15-G1/2-B-W3

xxx/xxx/xxx = pressure ranges see on page 18 (please indicate pressure ranges in bar)
Custom kits available upon request. Please contact STAUFF.

Series	Components	Order Codes	Series	Components	Order Codes
SMB-20-3-xxx/xxx/xxx-W3	2x Test hoses (2000 mm length)	SMS-20-2000-B-W3	SMB-15-3-xxx/xxx/xxx-W3	2x Test hoses (2000 mm length)	SMS-15-2000-B-W3
	3x Pressure gauges Ø 63 mm	SPG-063-xxx-...		3x Pressure gauges Ø 63 mm	SPG-063-xxx-...
	1x Gauge adaptor G1/4	SMA-20-G1/4-B-OR-W3		1x Gauge adaptor G1/4	SMA-15-G1/4-B-OR-W3
	2x Direct gauge adaptors G1/4	SMD-20-G1/4-B-OR-W3		2x Direct gauge adaptors G1/4	SMD-15-G1/4-B-OR-W3
	3x Test couplings G1/4	SMK-20-G1/4-B-C-W3		3x Test couplings G1/4	SMK-15-G1/4-B-B-W3
	3x Test couplings M10 x 1	SMK-20-M10x1-B-A-W3		3x Test couplings M14 x 1,5	SMK-15-M14x1.5-B-B-W3
	1x Thread adaptor G3/8	SRS-20-G3/8-B-W3		1x Thread adaptor G3/8	SRS-15-G3/8-B-W3
	1x Thread adaptor G1/2	SRS-20-G1/2-B-W3		1x Thread adaptor G1/2	SRS-15-G1/2-B-W3

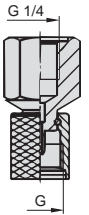
xxx/xxx/xxx = pressure ranges see on page 18 (please indicate pressure ranges in bar)
Custom kits available upon request. Please contact STAUFF.

Series	Components	Order Codes	Series	Components	Order Codes
SMB-20/100-1-xxx-W3	1x Test hose (2000 mm length)	SMS-20-2000-B-W3	SMB-15/100-1-xxx-W3	1x Test hose (2000 mm length)	SMS-15-2000-B-W3
	1x Pressure gauge Ø 100 mm	SPG-100-xxx-...		1x Pressure gauge Ø 100 mm	SPG-100-xxx-...
	1x Gauge adaptor G1/2	SMA-20-G1/2-B-OR-W3		1x Gauge adaptor G1/2	SMA-15-G1/2-B-OR-W3
	1x Direct gauge adaptor G1/2	SMD-20-G1/2-B-OR-W3		1x Direct gauge adaptor G1/2	SMD-15-G1/2-B-OR-W3
	1x Test coupling G1/2	SMK-20-G1/2-B-C-W3		1x Test coupling G1/4	SMK-15-G1/4-B-B-W3
	1x Test coupling M10 x 1	SMK-20-M10x1-B-A-W3		1x Test coupling M14 x 1,5	SMK-15-M14x1.5-B-B-W3
	1x Thread adaptor G3/8	SRS-20-G3/8-B-W3		1x Thread adaptor G3/8	SRS-15-G3/8-B-W3
	1x Thread adaptor G1/2	SRS-20-G1/2-B-W3		1x Thread adaptor G1/2	SRS-15-G1/2-B-W3


xxx/xxx/xxx = pressure ranges see on page 18 (please indicate pressure ranges in bar)
Custom kits available upon request. Please contact STAUFF.

Accessories (Connection Adaptors)

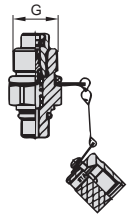
Adaptor	Adaption from	to Dimension G
SDA-20-G1/4-W3	G1/4	M16 x 2
SDA-15-G1/4-W3	G1/4	M16 x 1,5
SDA-12-G1/4-W3	G1/4	S12,65 x 1,5
SAD-20/15-B-W3	M16 x 2	M16 x 1,5
SAD-20/12-B-W3	M16 x 2	S12,65 x 1,5
SAD-20/10-B-W3	M16 x 2	Plug-in system



SDA adaptor
Connects the pressure gauge to a test coupling



SAD adaptor
Only in conjunction with the SDA-20-G1/4-W3 adaptor, connects to other test coupling sizes



Test coupling
STAUFF Test or comparable

Other adaptors are available.

Digital Pressure Gauge - Type SPG-DIGI / SPG-DIGI-USB (Data Logger)

A

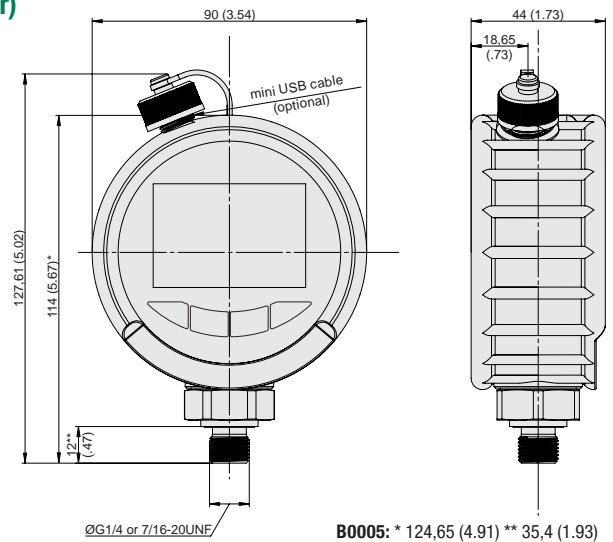
With Data Logger and USB Interface



SPG-DIGI



SPG-DIGI-USB



Product Description

The STAUFF SPG-DIGI digital pressure gauges are designed for digital measurement and display of pressure in hydraulic systems, especially for oils, lubricants and water. Current measured values as well as min and max values can be displayed with a precision of 0.5% of the full scale value.

The SPG-DIGI is optionally available in the USB version, equipped with an internal data memory. A measurement started on the measuring device is automatically stored in the internal data memory in the universal .csv file format. The measurement data can then be transferred to the PC using the supplied mini USB cable. The device shows up on the PC as a USB data storage medium, so that no additional software is required for transferring the data. This allows easy export of the data, e.g. into Microsoft Excel®.

The measurement data are stored in the internal memory with a resolution of up to 100 ms for short measurements and a pressure peak monitoring of 10 ms. Up to ten measurement series can be stored in the device. The maximum measurement duration for each measurement is 24 h.

The STAUFF SPG-DIGI digital pressure gauges are available individually or as part of a complete pressure test kit. They are very robust, reliable, easy to operate and bear a CE mark.

Features

- Bar graph display (drag pointer)
- Backlit display
- Zero point correction
- Battery status indicator
- Gauge ability to swivel 360°

Technical Data (for SPG-DIGI-USB)

- Internal memory: 10 measurement series
- Measurement data lengths: max. 24 h
- Memory interval: up to 100 ms (increases with duration of measurement)
- Pressure peak detection min/max: 10 ms
- Date type: Date / time / pressure value / min. pressure / max. pressure
- Data format: CSV

A USB connecting cable is supplied as a standard.

Order Codes



① Series and Type

Digital Pressure Gauge	SPG-DIGI
Digital Pressure Gauge USB	SPG-DIGI-USB

② Pressure Ranges

-1 ... 5 bar / -14.5 ... 72 PSI	B0005
-1 ... 16 bar / -14.5 ... 232 PSI	B0016
0 ... 100 bar / 0 ... 1450 PSI	B0100
0 ... 400 bar / 0 ... 5801 PSI	B0400
0 ... 600 bar / 0 ... 8702 PSI	B0600
0 ... 1000 bar / 0 ... 14504 PSI	B1000

③ Process Connection

G1/4	B
7/16-20 UNF	U

④ Calibration

without calibration certificate	(none)
with calibration certificate	CAL

Pressure Ranges

Version	Pressure Range (bar/PSI)	Maximum Pressure (bar/PSI)	Burst Pressure (bar/PSI)
B0005	-1 ... 5	30	50
	-14.5 ... 72	435	725
B0016	-1 ... 16	32	160
	-14.5 ... 232	464	2321
B0100	0 ... 100	200	800
	0 ... 1450	2900	11603
B0400	0 ... 400	800	1700
	0 ... 5801	11603	24656
B0600	0 ... 600	1200	2400
	0 ... 8702	17404	31908
B1000	0 ... 1000	1500	2500
	0 ... 14504	21756	36259

Technical Data

Materials

- Housing made of die-cast Zinc with TPE
- Wetted parts: Stainless Steel 1.4404, NBR (Buna-N®), ceramics
- Seals: NBR (Buna-N®) FKM (Viton®) or EPDM on request

Weight

- Max. weight: 360 g / .79 lbs

Display

- Text display 4 1/2 digits
- Size: 50 x 34 mm / 1.97 x 1.34 in
- Actual value display: 15 mm / .59 in
- MIN/MAX or FS* display: 8 mm / .31 in
- Units: bar, PSI, Mpa (not for 5 bar and 16 bar), kPa (not for 1000 bar), mbar (only for 5 bar and 16 bar)

- Pressure peak measurement with 10 ms sampling rate
- Illuminated measured value display

Accuracy

- ±0.25% FS* typ. / ±0.5% FS* max.

Permissible Temperature ranges

- Ambient temp.: -10 °C ... +50 °C / +14 °F ... +122 °F
- Media temp.: -20 °C ... +80 °C / -4 °F ... +176 °F
- Storage temp.: -20 °C ... +60 °C / -4 °F ... +140 °F
- Relative humidity: < 85%
- Battery life: SPG-DIGI: max. 1500 hours
SPG-DIGI-USB: max. 600 hours

(operation without illumination, 2 x 1.5 V DC AA (LR6-AA) alkaline)

Process Connections

- G1/4 or 7/16-20 UNF, Stainless Steel 1.4404
- Vibration: IEC 60068-2-6 / 10 ... 500 Hz / 5 g
- Shock: IEC 60068-2-27 / 11 ms / 25 g
- Load change (10³): 100

Protection Rating

- IP 65: Dust-tight and protected against water jets (SPG-DIGI-USB: IP65 only with cover installed)

* FS = Full Scale

Pressure Test Kit (digital) ▪ Type SMB-DIGI

A



Digital Pressure Test Kit (SPG-DIGI-USB)

Order Codes

SMB-DIGI	-	20	-	B0016	-	B	-	CAL
①		②		③		④		⑤

① Series and Type

Pressure Test Kit with SPG-DIGI	SMB-DIGI
Pressure Test Kit with SPG-DIGI-USB	SMB-DIGI-USB

② Adaptor Version

Adapts to STAUFF Test 20 (M16 x 2)	20
------------------------------------	-----------

③ Pressure Ranges

-1 ... 5 bar / -14.5 ... 72 PSI	B0005
-1 ... 16 bar / -14.5 ... 232 PSI	B0016
0 ... 100 bar / 0 ... 1450 PSI	B0100
0 ... 400 bar / 0 ... 5801 PSI	B0400
0 ... 600 bar / 0 ... 8702 PSI	B0600

④ Process Connection

G1/4	B
7/16-20 UNF	U

⑤ Calibration

Without calibration certificate	(none)
With calibration certificate	CAL

Product Description

In addition to the individual SPG-DIGI devices, the STAUFF Digital Pressure Gauges are also available as part of a pressure test kit.

The SMB-DIGI pressure test kits are assembled in various versions, in accordance with customer wishes. All pressure test kits are supplied in a handy case with custom-designed foam inserts.

Components

Standard Option SMB-DIGI-20

- Digital Pressure Gauge SPG-DIGI or SPG-DIGI-USB*
- Test Hose (2 m / 6.56 ft), M16 x 2, pressure-resistant 600 bar (8702 PSI) SMS-20-2000-B-W3
- Adaptor SDA (G1/4 to M16 x 2) SDA-20-G1/4-W3
- Hose Connector SSV-20-W3
- Test Coupling SMK-20-G1/4-B-C-W3
- Test Coupling SMK-20-M10x1-B-A-W3
- Thread Adaptor SRS-20-G3/8-B-W3
- Thread Adaptor SRS-20-G1/2-B-W3
- Quickguide
- *Supplied with a mini USB connecting cable

Pressure Ranges

Version	Pressure Range (bar/PSI)	Maximum Pressure (bar/PSI)	Burst Pressure (bar/PSI)
B0005	-1 ... 5	30	50
	-14.5 ... 72	435	725
B0016	-1 ... 16	32	160
	-14.5 ... 232	464	2321
B0100	0 ... 100	200	800
	0 ... 1450	2900	11603
B0400	0 ... 400	800	1700
	0 ... 5801	11603	24656
B0600	0 ... 600	1200	2400
	0 ... 8702	17404	31908

Accessories (Connection Adaptors)

<p>SDA adaptor Connects the pressure gauge to a test coupling (Max. Pressure 630 bar / 9137 PSI)</p>	<p>SAD adaptor Only in conjunction with the SDA-20-G1/4-W3 adaptor, connects to other test coupling sizes (Max. Pressure 630 bar / 9137 PSI)</p>	<p>Test coupling STAUFF Test or comparable (Max. Pressure 630 bar / 9137 PSI)</p>	<table border="1" style="width: 100%; border-collapse: collapse;"> <thead> <tr> <th>Adaptor</th> <th>Adaption from</th> <th>to Dimension G</th> </tr> </thead> <tbody> <tr> <td>SDA-20-G1/4-W3</td> <td>G1/4</td> <td>M16 x 2</td> </tr> <tr> <td>SDA-15-G1/4-W3</td> <td>G1/4</td> <td>M16 x 1,5</td> </tr> <tr> <td>SDA-12-G1/4-W3</td> <td>G1/4</td> <td>S12,65 x 1,5</td> </tr> <tr> <td>SAD-20/15-B-W3</td> <td>M16 x 2</td> <td>M16 x 1,5</td> </tr> <tr> <td>SAD-20/12-B-W3</td> <td>M16 x 2</td> <td>S12,65 x 1,5</td> </tr> <tr> <td>SAD-20/10-B-W3</td> <td>M16 x 2</td> <td>Plug-in system</td> </tr> </tbody> </table>	Adaptor	Adaption from	to Dimension G	SDA-20-G1/4-W3	G1/4	M16 x 2	SDA-15-G1/4-W3	G1/4	M16 x 1,5	SDA-12-G1/4-W3	G1/4	S12,65 x 1,5	SAD-20/15-B-W3	M16 x 2	M16 x 1,5	SAD-20/12-B-W3	M16 x 2	S12,65 x 1,5	SAD-20/10-B-W3	M16 x 2	Plug-in system
Adaptor	Adaption from	to Dimension G																						
SDA-20-G1/4-W3	G1/4	M16 x 2																						
SDA-15-G1/4-W3	G1/4	M16 x 1,5																						
SDA-12-G1/4-W3	G1/4	S12,65 x 1,5																						
SAD-20/15-B-W3	M16 x 2	M16 x 1,5																						
SAD-20/12-B-W3	M16 x 2	S12,65 x 1,5																						
SAD-20/10-B-W3	M16 x 2	Plug-in system																						

Other adaptors are available.



Introduction 24

Overview 25

Hydraulic Testers 26 - 35

 PPC-04-plus
PPC-04-plus-CAN 25

 PPC-PAD-light
PPC-PAD-light-CAN 28

 PPC-PAD-plus 32

Pressure Sensors 36 - 37

 Sensor-PPC-04/12-P 36

 Sensor-PPC-CAN-P 37

Temperature Sensors 38 - 39















 Sensor-PPC-04/12-T 38

 Sensor-PPC-CAN-T 39

Pressure / Temperature Sensors 40 - 41

 Sensor-PPC-04/12-PT 40

 Sensor-PPC-CAN-PT 41

	Flow Turbine	42 - 43		Wireless Pressure Measurement System	53 - 61
				PT-RF	
	Flow-meter-PPC-04/12-SFM	42		Overview	53
	Flow-meter-PPC-CAN-SFM	43		Pressure Transmitter	54
				PT-RF	
	Other sensors and cables	44 - 47		Reader	55
				Reader-PT-RF	
	Rotational Speed Sensor	44		Complete Systems	56
	Sensor-PPC-04/12-SDS-CAB			PT-RF-SET	
	Current / Voltage / Frequency Converter	45		Accumulator Adaptor	58
	Sensorconverter-PPC			SBAA / SBAA-P / SDAA	
	Accessories	46		Flow Indicators	62 - 63
	CAN Accessories	47		Flow Indicators	62
				SDM / SDMCR	
	Complete Systems	48 - 50			
	PPC-04-plus-SET and PPC-PAD-light-SET	48			
	PPC-04-plus-CAN-SET and PPC-PAD-light-CAN-SET	49			
	PPC-PAD-plus (Starter System)	50			
	Ordering Tables	51 - 52			
	Hydraulic Testers	51			
	Sensors	52			

Hydraulic Testers of the PPC Series



The STAUFF measuring and test equipment from the PPC Series is ideal for measuring all relevant parameters in fluid technology systems such as pressure, differential pressure, temperature, flow rate and power.

Depending on the type, they enable evaluation, storage and further processing in PCs or notebooks. They have been specially developed to meet the growing requirements for system monitoring, troubleshooting and measured value determination in hydraulic and pneumatic systems. All versions offer automatic sensor recognition, thus eliminating the need for tedious and often time-consuming parameterisation of sensors. The intuitive keypad or touch screen makes it easy to control the devices and change the measuring units via the menu.

There are many different areas of application:

- Industrial hydraulics
- Mobile, agricultural and forestry hydraulics
- Ship and offshore hydraulics
- Chemicals and petrochemicals
- Energy and air-conditioning systems
- Heating and sanitary systems

The PPC-04-plus hydraulic measuring and testing devices are characterised, among other things, by their uncomplicated operation. Even in difficult lighting conditions, it is possible to read the measured values quickly and reliably thanks to the multi-line, backlit LCD display. The hydraulic measuring device is available in two versions, either with 2 inputs for analogue STAUFF Sensors or with a CAN interface for connecting up to 3 STAUFF CAN Sensors. Both versions are equipped with an internal data memory and a USB port and are powered by an internal power supply (Lithium Ion battery). With the software supplied, it is possible to display the measured values not only as numerical values but also as diagrams on the PC.

Depending on the version, the PPC-PAD-light series measuring devices offer the option of connecting 4 analogue STAUFF Sensors or 6 STAUFF CAN Sensors.

Third-party sensors (e.g. 4-20 mA or 0-10 V) can also be operated with these devices without any problems. Both measuring devices have a large internal data memory and an integrated USB interface and can be operated for several hours on battery power. All measurement data can be easily visualised and settings made on the 4.3" touch display.

The most powerful device in this family of measuring devices is the PPC-PAD-plus. This multifunctional device has been specially adapted to the increased requirements of fluid technology and users.

The measured values can be shown in various display modes on the large 7" touch display, enabling effective, solution-oriented analyses. The device has a modular sensor input design. This means that the basic device can be expanded to include up to 6 analogue STAUFF Sensors and up to 48 STAUFF CAN Sensors by using additional input modules.

It also offers extensive options for saving countless and varied measurement tasks as 'templates' and calling them up immediately when required. This means that even complex, recurring measurement tasks can be started more or less immediately.

The hydraulic measuring and testing devices and the sensors of the PPC series are of course also available in a calibrated version and are supplied with a calibration certificate (factory calibration).

Subsequent calibration can be requested via a special order designation.

Hydraulic Testers of the PPC Series ■ Product Overview
B

Hydraulic Testers					
Options	PPC-04-plus	PPC-04-plus-CAN	PPC-PAD-light	PPC-PAD-light-CAN	PPC-PAD-plus

Connection principle	Analogue sensors	CAN sensors	Analogue sensors	CAN sensors	Analogue sensors + CAN sensors
Battery mode	●	●	●	●	●
Number of sensor inputs	up to 2 analogue STAUFF Sensors	up to 3 STAUFF CAN Sensors	up to 4 analogue STAUFF Sensors	up to 6 STAUFF CAN Sensors	up to 6 analogue STAUFF Sensors and up to 48 STAUFF CAN Sensors
Option for adding sensor inputs	–	–	–	–	●
PC interface	Micro-USB	Micro-USB	USB-C	USB-C	USB / Ethernet / WLAN
Online function	●	●	●	●	●
Internal data memory	●	●	●	●	●
Programming of automatic test sequence	–	–	●	●	●
Trigger function	–	–	●	●	●
Touch screen	–	–	●	●	●
Illuminated display	●	●	●	●	●
Curve shown on the display	–	–	●	●	●
PC software kit	●	●	●	●	●

Pressure measurement	●	●	●	●	●
Temperature measurement	●	●	●	●	●
Flow rate measurement	●	●	●	●	●
Rotational speed measurement	●	–	●	–	●
Frequency measurement	with optional current/voltage/frequency converter	with optional current/voltage/frequency converter	with optional current/voltage/frequency converter	with optional current/voltage/frequency converter	integrated into the device
Third-party analogue sensors	with optional current/voltage/frequency converter	with optional current/voltage/frequency converter	integrated into the device	optional	integrated into the device
Third-party CAN sensors	–	–	–	–	an CAN-Y max. 5 third-party sensors

● = standard, – = not available

Hydraulic Testers ■ Type PPC-04-plus / PPC-04-plus-CAN

B



PPC-04-plus with 2 sensor inputs for max. 2 analogue STAUFF Sensors



PPC-04-plus-CAN with CAN interface for up to 3 STAUFF CAN Sensors (max. 50 m / 164 ft cable length)

Product Description

The PPC-04-plus and PPC-04-plus-CAN Hydraulic Testers have been developed for the growing demands in mobile and industrial hydraulic systems. They are perfectly suited for the precise determination of pressure, temperature, volume flow and rotational speed.

- Multi-line, backlit LCD display
- Max. 2 analogue STAUFF Sensors can be connected at the same time
- With CAN interface, max. 3 CAN STAUFF Sensors can be connected at the same time
- Integrated data memory for 15000 data records (max. 24 hours)
- External storage by using a USB memory stick (1 GB included)
- Max. cable length: 50 m / 164 ft (CAN version)

The Hydraulic Testers are available in two versions. The PPC-04-plus, analogue version, comes with two inputs for connecting up to 2 analogue STAUFF Sensors at the same time. The PPC-04-plus-CAN comes with a CAN interface for connecting up to 3 CAN STAUFF Sensors at the same time. Both versions provide automatic sensor recognition, thus making the tedious and often time-consuming parameterization of sensors redundant. The units can be easily operated via the keyboard and the individual device configurations can be viewed and managed.

Due to its extremely robust construction and oil-resistant rubber coating, the Hydraulic Testers can withstand impacts, vibrations, dust and moisture (protection class up to IP 67) and is designed for use in particularly harsh conditions.

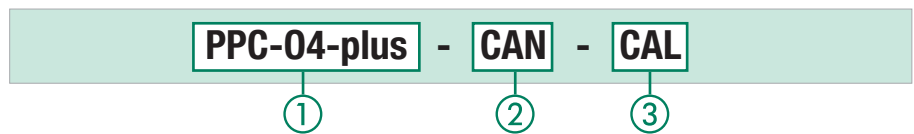
The internal battery (Lithium Ion pack) can be charged via a micro USB connection, this connection can be also used to transfer the internally stored data to a PC or notebook. Furthermore, this connection is also provided for real-time presentation of the measured values on the PC.

The PPC-04-plus devices can store up to 15000 data records and 270000 measured values. The included PPC software is compatible with popular Windows® PC operating systems and permits various evaluation methods.

It is also possible to connect the Pressure Sensors under load, with the equipment switched on. The temperature and volume flow sensors are to be installed in the pipelines. The Rotational Speed Sensor is a non-contacting sensor and uses an optical mark on the rotating parts. Measuring the differential pressure requires two Pressure Sensors with identical measuring ranges.

The units are also available as a complete set. See pages 48 / 49 for further information.

Order Codes



① Series and Type

Hydraulic Tester **PPC-04-plus**

② Version

Analogue STAUFF Sensors **(none)**
STAUFF CAN Sensors **CAN**

③ Calibration

Without calibration certificate **(none)**
With calibration certificate (factory calibration) **CAL**

Note:
Calibration certificate is only available for the analogue Hydraulic Tester PPC-04-plus.

Technical Data

Materials

- Housing made of ABS in a rubber protective

Dimensions and Weight

- W x H x D: 96 x 172 x 54 mm / 3.78 x 6.77 x 2.13 in
- Weight: ca. 540 g / 1.19 lbs

Measurements / Display

- Pressure: in bar, PSI, mbar, kPa, MPa
- Temperature: in °C and °F
- Volume flow: in l/min and US GPM
- Rotational speed: in 1/min and RPM
- Display: FSTN-LCD, graphic, LED backlit
- Visible area: 62 x 62 mm / 2.44 x 2.44 in
- Resolution: 130 x 130 Pixel
- Internal measured value memory: 1 measurement, approx. 15000 data sets (270000 measured values ACT/MIN/MAX), max. 24 h per measurement

Power Supply

- External: Micro USB socket, type B +5V DC, max. 1000 mA
- Battery: Lithium Ion pack 3,7 V DC / 2250 mAh or 3,7 V DC / 4500 mAh CAN version
- Operating time with the rechargeable battery: approx. 8 hours

Sensor Inputs

- Push-in connection: 5-pol., push-pull or 5-pol., M12x1, connector (CAN version)
- Automatic sensor recognition
- Sampling rate: 1 ms
- Accuracy: $\pm 0,2\% FS^* \pm 1 \text{ Digit}$

Permissible Temperatures

- Ambient: 0°C ... +50 °C / +32 °F ... +122 °F
- Storage: -25 °C ... +60 °C / -13 °F ... +140 °F

- Relative humidity: < 80 %
- CE certified

Interfaces

- USB device: Online transmission between unit and PC via PPC-Soft-plus (software)
Measured value transmission: ACT/MIN/MAX, min. 5 ms
USB standard: 2.0, fullspeed
Push-in connection: Micro USB socket, shielded, type B
- USB host: Connection for USB stick, max. 4 GB
USB standard: 2.0, fullspeed, max. 100 mA
Push-on connection: USB socket, shielded, type A

Protection Rating

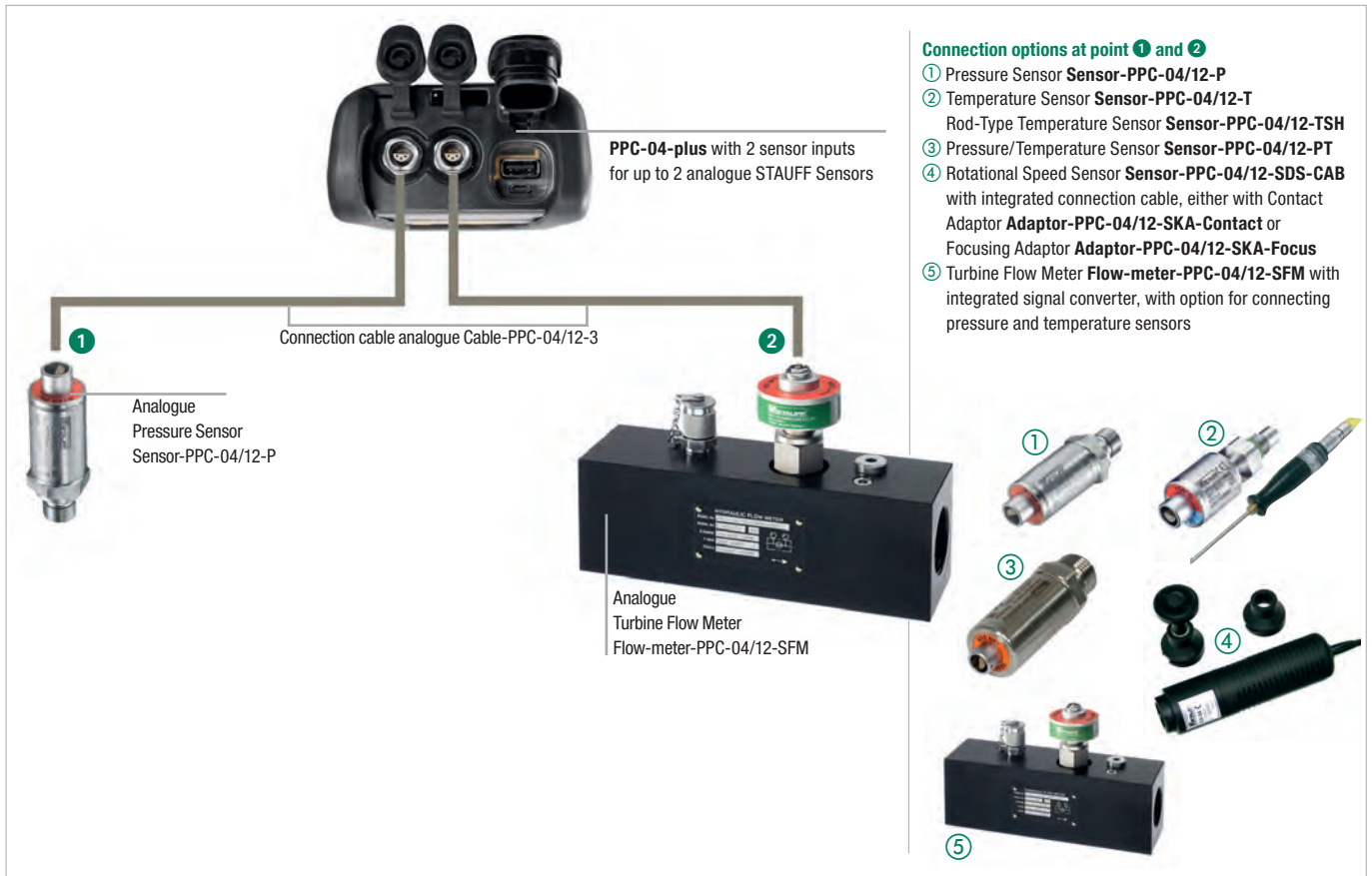
- IP 54 protection rating: Dust protected and protected against splashing water
- (CAN version)
IP 67 protection rating: Dust tight and protected against splashing water

Software

A PC set, consisting of a USB connection lead, length 1 m / 3.28 ft and the corresponding PC software, is included in the scope of delivery. The measured data and curves can be easily transferred and processed by using PPC-Soft-plus software as well as exported to Microsoft Excel®.

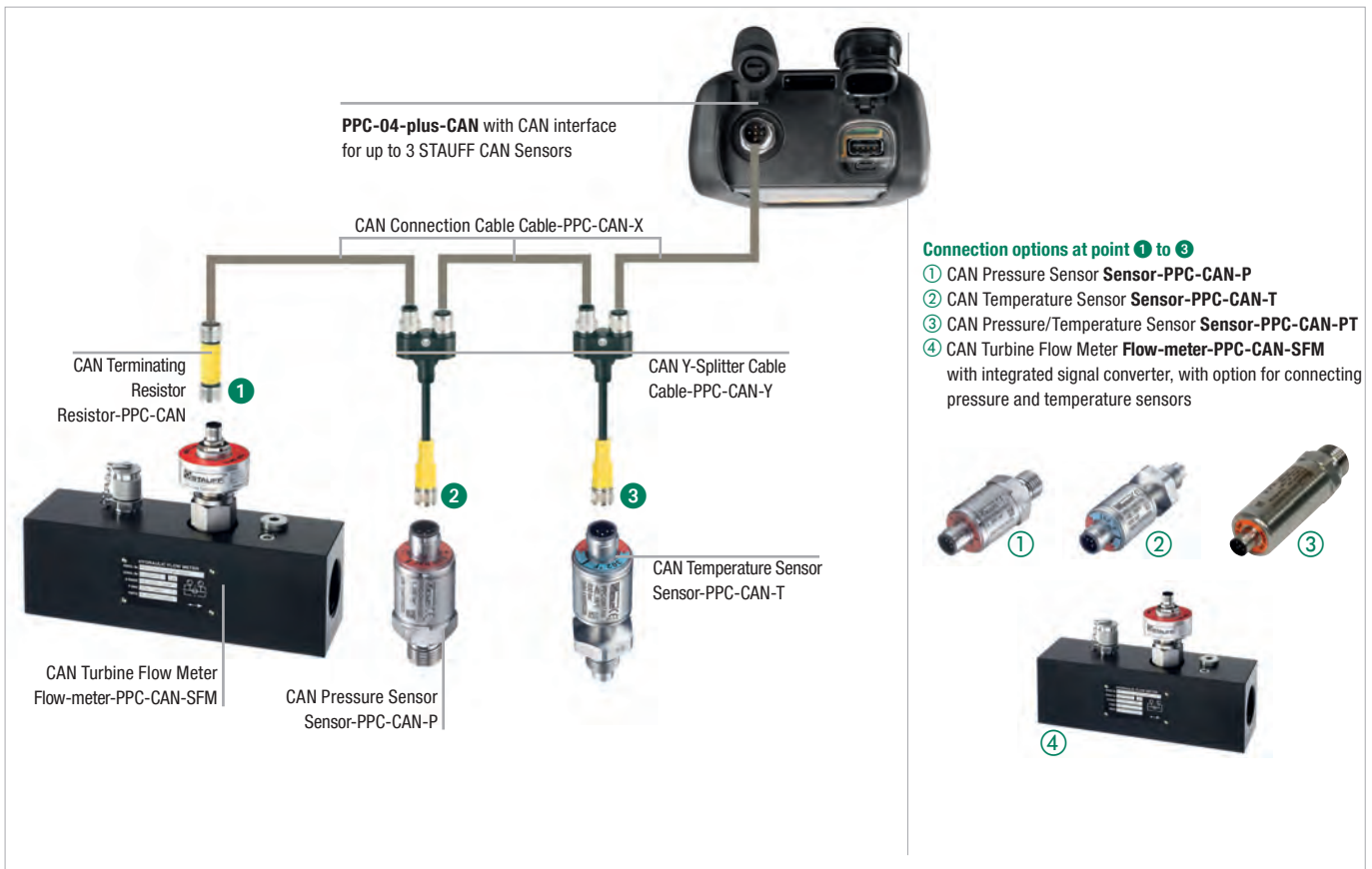
Dimensional drawings: All dimensions in mm (in).

Connection example for analogue STAUFF Sensors ▪ Type PPC-04-plus



B

Connection example STAUFF CAN Sensors ▪ Type PPC-04-plus-CAN



Hydraulic Tester ▪ Type PPC-PAD-light / PPC-PAD-light-CAN

B



Product Description

The PPC-PAD-light measuring devices have been specially developed to meet the growing demands of system monitoring and troubleshooting in hydraulic and pneumatic systems.

The ergonomically designed housing and the LCD display that automatically adjusts to the appropriate line size allow problem-free use even under difficult environmental conditions. The 4.3" touchscreen enables easy programming of the device and convenient visualisation of the measurement data.

The PPC-PAD-light can be used to measure, save and process all relevant hydraulic parameters such as pressure, differential pressure, temperature, speed, flow rate and hydraulic power.

The PPC-PAD-light and PPC-PAD-light-CAN devices differ in the type of sensor connection. The PPC-PAD-light can process up to 4 analogue STAUFF Sensors and the PPC-PAD-CAN up to 6 STAUFF CAN Sensors with max. cable length: 50 m / 164 ft (CAN version) simultaneously.

In particular, the extensive programming options and the internal memory capacity enable a wide range of measurement and evaluation procedures such as long-term measurements, trigger functions or the recording of data from external sensors (e.g. 4-20 mA or 0-10 V).

Thanks to automatic sensor recognition, the measuring devices are easy to operate and can be customised to customer requirements without the need for extensive programming.

The devices can be used to record measured values with a resolution of up to 1 ms = 1000 measured values/s. The measured values can be transferred to a PC or notebook at any time via the USB interface or retrieved directly via the built-in USB stick. The PPC software included in the scope of delivery is compatible with standard Windows® PC operating systems and enables a wide range of analyses.

The devices are also available as a complete system. Further information can be found on pages 48 / 49.

Product Features

- Automatic sensor recognition
- Curve display on screen
- Intuitive 4.3" touchscreen
- Large integrated data memory
- Long-term recording of MIN/MAX values possible
- Recurring measurement tasks can be programmed as templates
- Trigger function
- Online data transfer
- Integrated USB stick
- USB-C charging and data transfer

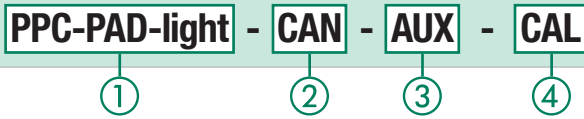


Function Description

- ① Automatic sensor recognition, simply plug in and measure
- ② USB interface to PC for online measurement or convenient evaluation and documentation via PPC Analyse software
- ③ Power supply via quick-charging USB-C power supply unit
- ④ Start/stop measurement with automatic data compression or manual setting of storage time and rate
- ⑤ Screenshots at the push of a button
- ⑥ Robust construction with oil-resistant rubber protection for use in harsh conditions
- ⑦ Additional tactile keypad for operation under difficult conditions
- ⑧ Measurement and display of up to 16 channels
- ⑨ 4.3" touch display and plain text navigation for easy operation, can also be operated with gloves
- ⑩ Curve diagram or numerical display
- ⑪ Pressure, temperature, flow rate, speed, frequency, etc. - everything is measured, stored, monitored and analysed

Hydraulic Tester ■ Type PPC-PAD-light / PPC-PAD-light-CAN

Order Codes



① Series and Type

 Hydraulic Tester **PPC-PAD-light**

② Version

 Analogue STAUFF Sensors **(none)**
 STAUFF CAN Sensors **CAN**

③ Third-party Sensor Input

 without Third-party Sensor Input **(ohne)**
 with Third-party Sensor Input **AUX**
 (e.g. 4-20mA or 0-10V)

④ Calibration

 Without calibration certificate **(none)**
 With calibration certificate (factory calibration) **CAL**
 (only PPC-PAD-light, PPC-PAD-light-CAN-AUX)

Delivery Includes

- Measuring device (according to the selection)
- USB stick 4GB
- Quick guide with link to software and complete instructions
- USB cable (type A to type C)
- Touch-Pen
- Power supply not included (please order separately)

Power supply

STAUFF relies on the new USB-C standard for the PPC-PAD-light. The measuring device can therefore be charged using different chargers. Fast charging as well as safe continuous operation can be achieved using the separately available fast-charging USB-C power supply unit.

Order code for quick charger:

Power-Supply-PPC-PAD-light-MULTI

Versions

The PPC-PAD-light is available in three different versions and therefore offers a wide range of options for different sensor types and configurations:



PPC-PAD-light for up to 4 analogue STAUFF Sensors with automatic sensor recognition and up to 2 analogue external sensors (e.g. 4-20 mA or 0-10 V).



PPC-PAD-light-CAN for up to 6 STAUFF CAN Sensors with automatic sensor recognition. (max. 50 m / 164 ft cable length)



PPC-PAD-light-CAN-AUX for up to 6 STAUFF CAN Sensors (max. 50 m / 164 ft cable length) with automatic sensor recognition and up to 2 external analogue sensors (e.g. 4-20 mA or 0-10 V).

Technical Data

Materials

- Housing: ABS/PC (thermoplastic)
- Protective housing cover: TPE (thermoplastic elastomer)

Dimensions and Weight

- W x H x D: 215 x 60 x 154 mm / 3.78 x 6.77 x 2.13 in
- Weight: ca. 810 g / 1.79 lbs
- VESA mount: 75 x 75 mm

Measurements / Display

- Pressure: in bar, PSI, mbar, kPa, MPa
- Temperature: in °C and °F
- Volume flow: in l/min and US GPM
- Rotational speed: in 1/min and RPM
- Display: 4.3" Touchscreen, 800 × 480 Pixel
- Data output with connection option for notebook and PC
- Data storage on USB stick, under protective cap

Power Supply

- internal Lithium Ion pack 7,2 V / 3500mAh / 25,44 Wh
- USB-C charging -> in accordance with IEC 62680-1-3, USB PD 3.0, 5 V, 12 V, 20 V, current consumption max. 2.5 A at 5 V, 1.8 A at 12 V, 1.2 A at 20 V
- A USB-C compatible charger with at least 45 W is required for fast charging
- Alternatively via USB-A/C cable (included) 5 V max. 2 A
- For long-term measurements, the use of a fast charger is recommended

Sensor Inputs PPC-PAD-light

- for up to 4 analogue STAUFF Sensors with automatic sensor recognition
- Plug connection: 5 pin, push-pull, combination Built-in plug/socket
- Sampling rate: 1 ms = 1,000 measured values/sec.
- Accuracy: 0.1% FS

Sensor Inputs PPC-PAD-light-CAN

- for up to 6 STAUFF CAN Sensors with automatic sensor recognition
- Plug connection: 5-pin, M12x1 panel connector (male)
- Sampling rate: up to 4 sensors 1 ms, 5 or 6 sensors 2 ms

Third-party Sensor Inputs (PPC-PAD-light and PPC-PAD-light-CAN-AUX)

- 1 connection with 2 inputs (analogue) for measuring current and voltage
- Voltage measuring range: -10...+10 VDC
- Current measuring range: 0/4...20 mA
- Supply for external sensors: 24 VDC +/-5 %, max. 350 mA (for both inputs)
- Plug connection: M12x1, 5 pin socket
- Sampling rate: 1 ms = 1000 measured values/s FAST-MODE 0.1 ms = 10000 measured values/s

Data output

- Integrated USB port (USB 2.0)
- Online data transfer to the PC
- Individually selectable speed (5 ms ... 60 s)
- USB-A socket: USB 2.0, full speed, 12 Mbit/s Max. memory size 128 GB

Ambient Conditions

- Ambient temperature: -10...+50 °C
- Storage temperature: -20...+60 °C
- Relative humidity: max. 95% non-condensing
- CE approval
- Protection class IP 65 (EN 60529:1989 +A1:1999 + A2:2013), all screw connections must be fitted with sensors or protective caps

Software

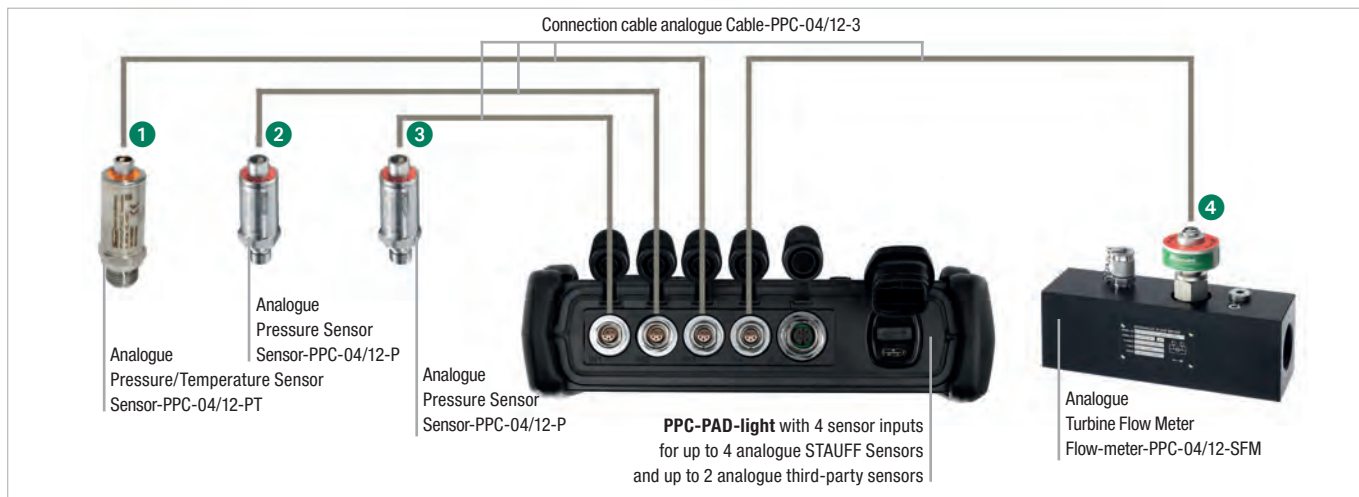
- A PC set, consisting of a USB connection cable, length 1.5 m / 4.9 ft and the corresponding PC software, is supplied as standard with every PPC-PAD-light and PPC-PAD-light-CAN. The measured data and measurement curves can be transferred and processed via the PPC-Analyze software and exported to Microsoft Excel®.

Accessories

- Pen: **Pen-PPC-PAD-light**
- Safety glass: **Protection-glas-PPC-PAD-light**
- Quick charger: **Power-Supply-PPC-PAD-light-MULTI**

Connection example for analogue STAUFF Sensors ▪ Type PPC-PAD-light

B

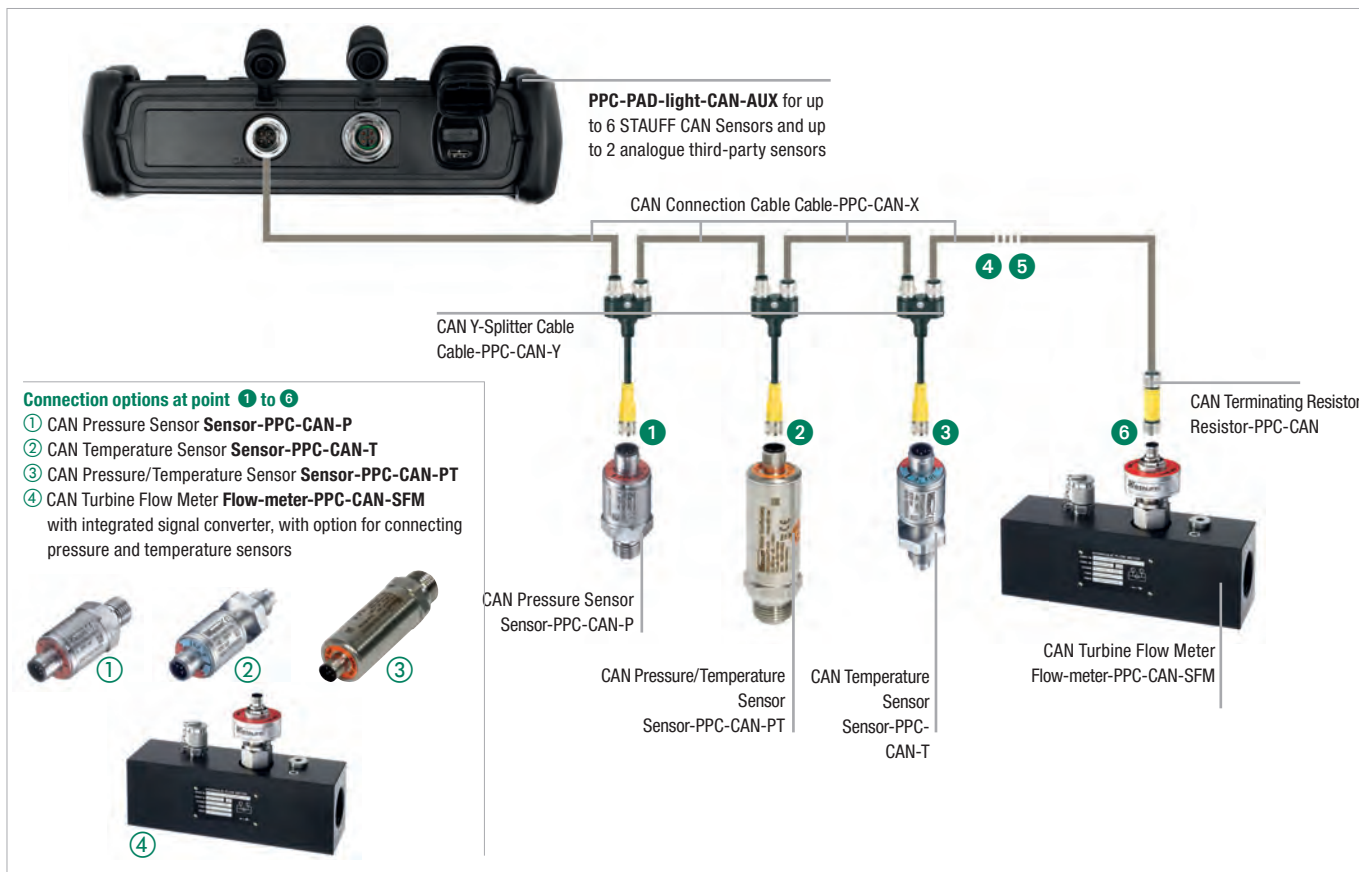


Connection options at point 1 to 4

- ① Pressure Sensor **Sensor-PPC-04/12-P**
- ② Pressure/Temperature Sensor **Sensor-PPC-04/12-PT**
- ③ Temperature Sensor **Sensor-PPC-04/12-T**
- ④ Rod-Type Temperature Senso **Sensor-PPC-04/12-TSH**
- ④ Rotational Speed Sensor **Sensor-PPC-04/12-SDS-CAB** with integrated connection cable, either with Contact Adaptor **Adaptor-PPC-04/12-SKA-Contact** or Focusing Adaptor **Adaptor-PPC-04/12-SKA-Focus**
- ⑤ Turbine Flow Meter **Flow-meter-PPC-04/12-SFM** with integrated signal converter, with option for connecting pressure and temperature sensors



Connection example STAUFF CAN Sensors ▪ Type PPC-PAD-light-CAN



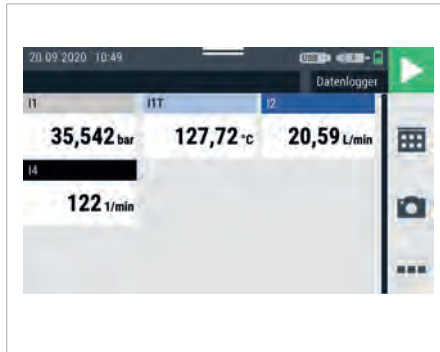
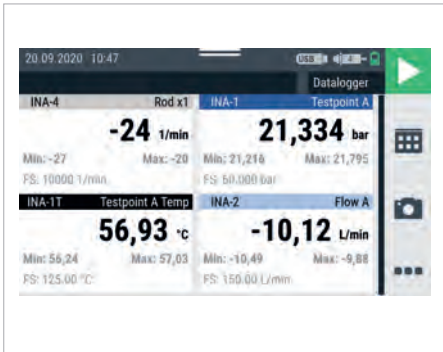
Connection options at point 1 to 6

- ① CAN Pressure Sensor **Sensor-PPC-CAN-P**
- ② CAN Temperature Sensor **Sensor-PPC-CAN-T**
- ③ CAN Pressure/Temperature Sensor **Sensor-PPC-CAN-PT**
- ④ CAN Turbine Flow Meter **Flow-meter-PPC-CAN-SFM** with integrated signal converter, with option for connecting pressure and temperature sensors



Hydraulic Tester ▪ PPC-PAD-light / PPC-PAD-light-CAN Display

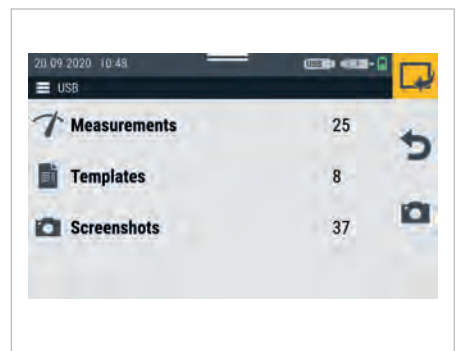
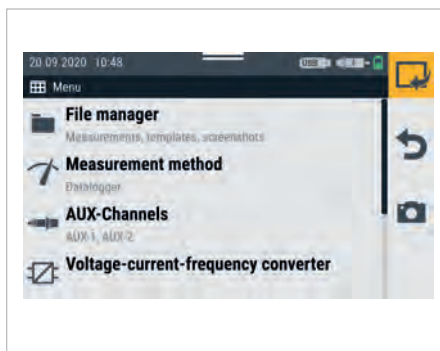
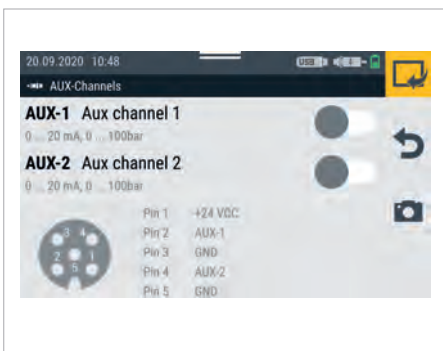
B



- Detailed overview of the channels including min/max and measuring range values

- Up to 9 channels in one display
- Colour assignment of the individual channels

- Curve visualisation directly on the display
- Free scalability using the two-finger principle
- Cursors with measured value and delta display can be shown for analysis purposes

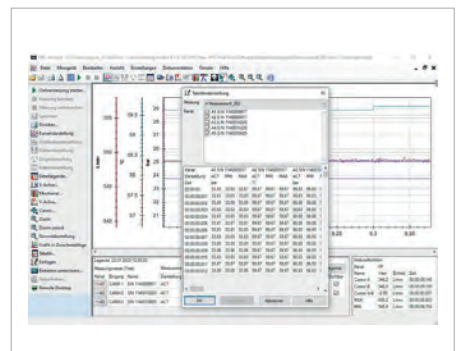
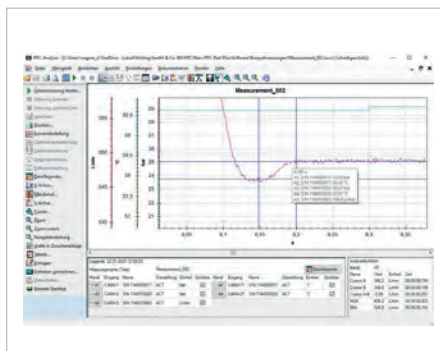
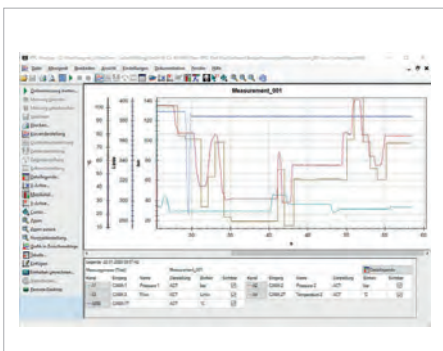


- Depending on the device type, up to 2 Third-party Sensors can be configured directly on the device
- Voltage measuring range: -10...+10 VDC or Current measuring range: 0/4...20 mA

- Intuitive menu navigation

- Loading recorded measurement data directly on the device

Hydraulic Tester ▪ PPC-PAD-light / PPC-PAD-light-CAN PC-Software PPC-Analyze



The PPC-Analyze Software that is included with the tester can display, analyse and export the recorded curves.

In addition, measurements can be shown on the monitor in real time using USB.

Hydraulic Tester ■ Type PPC-PAD-plus



Product Description

The application options for hydraulic technology have increased significantly in all areas of drive and control systems.

This trend is particularly evident in the fields of machinery, plant and automotive engineering. At the same time, hydraulics and electronics are becoming increasingly more interlinked.

The PPC-PAD-plus Multifunction Hand-Held Hydraulic Tester was developed especially for high demands and helps you to master these new challenges. It has never been so easy to track the complex processes in these industries through measurements, displays and analyses. Possible areas of application include preventive maintenance, commissioning, troubleshooting and machine optimisation. The increased requirements of these modern applications (e.g. more measuring points, longer cables and higher immunity to interference) have driven the further development of the CAN bus.

The new PPC-PAD-plus has a 7" touch screen which makes operation very simple, even for complex tasks.

The modular design also ensures best possible adaptation to a variety of different measuring tasks. Different input modules are offered for connecting additional sensors. These modules can easily be replaced by the user. There is an option of running the basic device with max. two additional modules in the device.

The CAN Bus Sensors from STAUFF use the automatic sensor detection of the bus to allow an easy-to-install plug-and-play solution (max. CAN bus length 100 m/328 ft).

One great advantage is the option to generate a variety of different templates for recurring measuring tasks and saving these in so-called containers. Calling up these templates for recurring measuring tasks ensures interpretation and comparability of the results at all times. This can even go so far as executing these templates automatically at the press of a button.

The newly integrated WIFI function also allows the device to be controlled via remote access, which means that executing measuring tasks and calling up the recorded data from a different location are no longer a challenge.

The PPC-Analyze PC Software offers additional methods for analysis, control and remote service using LAN and USB connections. In combination with this software, the PPC-PAD-plus is a very user-friendly hydraulic tester that is suitable for all types of diagnostic applications.

Product Features (for basic device)

- Portable multifunction hand-held tester
- Measuring, monitoring and analysis of pressure, temperature, volumetric flow rate and mass flow rate
- Measurement recording with a resolution of up to 1 ms
- Measurement and display of over 50 channels
- Sensor inputs can be expanded with additional input modules
- 2 frequency inputs for connecting third-party sensors or digital inputs/outputs
- 7" touch display, suitable for operation with gloves, robust 3 mm glass, resolution 800 x 480 pixels
- Connection of third-party CAN open sensors possible
- Analogue input module with galvanic isolation available
- Display of measured values: numerical, bar graph, pressure gauge, points, curve diagram
- Saving and loading project templates
- Defining of quick values possible (green, yellow, red)
- Memory for up to 1 billion measured values
- The measured data can be recorded (automatically), saved and analysed with the PPC-Analyze PC Software over a LAN, WIFI or USB connection.
- Max. CAN bus length: 100 m/328 ft

Technical Data (for basic device)

Inputs/Outputs

- CAN sensor inputs:
 - 2 CAN bus networks, each with 24 STAUFF CAN bus channels. Alternatively on CAN Y with up to 5 third-party CAN open sensors. Baud rate adjustable for third-party CAN.
 - 24 V DC power supply/max. 250 mA.
 - Mixed operation of STAUFF CAN and third-party CAN within one CAN bus line not possible.
 - Internal terminating resistor 120 Ω.
 - Supports CAN 2.0 A/CAN 2.0 B
- Sampling rate: 1 ms = 1000 measured values/s
- Plug-in connection: M12x1; 5-pin with, integrated connector
- Digital input/output and frequency input:
 - Dual assignment input that can be used either as DIGITAL-IN and DIGITAL-OUT, or two frequency inputs are provided through switchover. Also possible as detection of direction of rotation.
- Connection: M12x1 female (5-pin)
- Input: Galvanically isolated
- Power supply: 24 V DC, 80 mA
- Input signals: Frequency (0 Hz...20 kHz)
- Level/threshold: Active low: 0...1.4 V, Active high: 3...30 V
- Accuracy: ≤ ±0.1%
- Input module slots: Flexible addition of up to 2 modules

Touch Display

- Size/resolution: 7", 800 x 480 pixels
- Brightness: 450 cd.
- Can be operated with gloves

Calculation Channels

- Number: 4
- Functions: /, *, +, -, f'(t), Integral, sin, cos, tan, x², SQRT, xy
- Maximum number of calculation from channels/ calc channel: 3

Interfaces

- USB device: Data transfer between device and PC
- USB host 1+2: USB 2.0, connection of external memory media
- Internal memory: 12 GB
- LAN: Connection of network cables
- Wireless communication:
 - PPC-PAD-plus-W: WIFI

Ambient Conditions

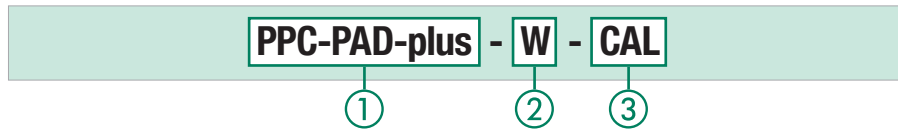
- Ambient temperature: -10...+50 °C
- Storage temperature: -20...+60 °C
- Rel. humidity: < 80%
- Environmental testing: 1 m drop test (EN 60721-3-7)
- Vibrations: EN 60721-3-7, 7M3
- Protection rating: IP 65 (EN/IEC 60529:2014)
- External power supply:
 - 110/240 V AC - 24 V DC/3.5 A
- Connection: 3-pin

Rechargeable Battery

- Lithium-ion pack, 14.4 V/3350 mAh

Materials

- Housing: ABS/PC (thermoplastic)
- Protective housing cover: TPE (thermoplastic elastomer)
- Flammability rating: UE94V0
- Dimensions (w x h x d): 282 x 195 x 85 mm
- Weight: 1880 g (without input module)
- VESA connection: 100 x 100 mm / M4 metric

Hydraulic Tester ■ Type PPC-PAD-plus
Order Codes for Basic Device

① Series and Type

Hydraulic Tester	PPC-PAD-plus
------------------	---------------------

② Version

Without WIFI	(none)
With WIFI*	W

③ Calibration

Without calibration certificate	(none)
With calibration certificate (factory calibration)	CAL

Delivery Includes

- PPC-PAD-plus Hydraulic Tester Connection for 2 CAN bus networks (optional modules, see below)
- Power Supply Unit 110 V/240 V – 24 V DC/2.5 A incl. country-specific adaptor (EN, US, UK, AUS)
- USB 2.0 cable (2 m/6.56 ft)
- Quick guide with link to software and complete instructions
- PC Software

* Only approved for Europe

B
Expansion Modules (Input Modules) for the PPC-PAD-plus

The PPC-PAD-plus is equipped with two input module slots for individually adapting the device to the application. The input modules are available in various versions and can easily be retrofitted or replaced by the user. The analogue input modules are also available with a calibration certificate.

Product Characteristics / Technical Data (for input modules)
Analogue Input Module

The analogue input module is equipped with three analogue connections IN 1 – 3 for sensors with automatic sensor detection (STAUFF ANALOGUE) and an analogue connection IN 4/5 for up to two third-party sensors without automatic sensor detection (e.g. standard industrial sensors).

- 3 sensor inputs with sensor detection (p/t/Q/n) for PPC sensors
- Plug-in connection: 5-pin, push-pull, combination integrated male/female connector
- Sampling rate: 1 ms = 1000 measured values/s
- Operating temperature range: -10 °C...+50 °C
- Rel. humidity: < 80%
- Storage temperature range: -20 °C...+60 °C
- Weight: 152 g
- Input for third-party sensors: 2 sensor inputs (analogue), for measuring current and voltage
 - Sampling rate: 1 ms = 1000 measured values/s
 - Voltage measuring range: -10...+10 V DC
 - Current measuring range: 0/4...20 mA
 - Supply for ext. sensors: +24 V DC/max. 100 mA
 - Plug connection: M12x1; 5-pin female connector

Analogue Input Module with Galvanically Isolated Sensor Inputs

This input module offers the same options as the analogue input module, but with the connections galvanically isolated from the PPC-PAD.

- As the "analogue input module", but with sensors inputs galvanically isolated from the PPC-PAD-plus.

CAN Input Module

The CAN Input Module is equipped with two passive CAN bus connections for third-party sensors without automatic sensor detection (third-party CAN).

In addition, this slot offers the option of connecting the PPC-PAD to an existing CAN BUS network using the SAE J1939 protocol for the purpose of reading messages from other CAN bus nodes. This can be the bus of a vehicle or machine, for example. The CAN module is passive and cannot be detected by other CAN masters.

Both connections are galvanically isolated from each other and from the device.

- 2 x M12x1 5-pin connector input for connecting to CAN systems such as CANopen, CAN generic and SAE-J1939
- Plug-in connection: 2 x M12 5-pin female, CAN1xx, CAN2xx, each galvanically isolated
- Number of CAN1xx channels: 24
- Number of CAN2xx channels: 24
- Standards: CAN 2.0 A, CAN 2.0 B
- Supported protocols: CANopen, SAEJ1939 and CAN generic, mixed operation of several CAN protocols possible
- Terminating Resistor: Can be activated or deactivated
- Supply for signal connection: Passive, no external supply
- Operating temperature range: -10 °C...+50 °C
- Storage temperature range: -20 °C...+60 °C
- Weight: 127 g

Order Codes for Input Modules

① Type

Input Module	INPUT-MODUL
--------------	--------------------

② Version

Analogue STAUFF Sensors	ANALOG
STAUFF CAN Sensors	CAN

③ Series

PPC-PAD-plus	PPC-PAD-plus
--------------	---------------------

④ Galvanically Isolated

Not galvanically isolated	(none)
Galvanically isolated (only for Analogue Version)	GALV

⑤ Calibration

Without calibration certificate	(none)
With calibration certificate (factory calibration)	CAL

Hydraulic Tester ■ Type PPC-PAD-plus

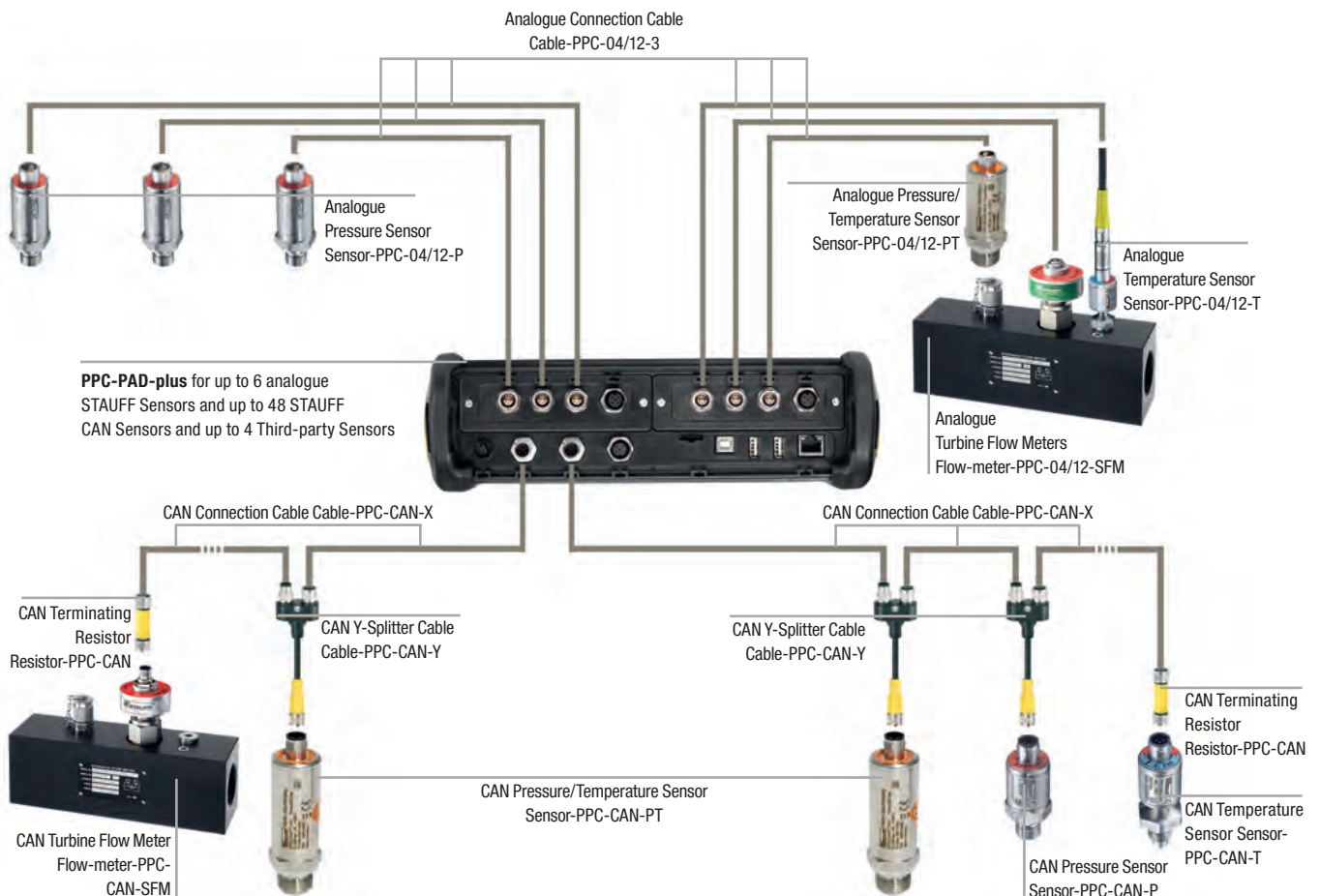
B



Function Description

- ① Illuminated, glare-free colour display for good readability in all situations, 7" size for a clear overview of comprehensive information
- ② Suitable for operation with gloves, robust 3 mm glass, resolution 800 x 480 pixels
- ③ High protection against moisture and dirt, protection rating IP 65
- ④ Intuitive operation with clear icons and function-related buttons and apps
- ⑤ Integrated mount for carrying strap
- ⑥ Robust, oil-resistant housing protection for use in rough environments and for absorbing impacts
- ⑦ Additional large tactile keyboard for reliable operation even in difficult conditions
- ⑧ Optional CAN Module for monitoring CAN systems or connecting third-party CAN sensors
- ⑨ Optional analogue input module for connecting STAUFF Sensors with sensor detection
- ⑩ USB host interface for connecting USB mass storage devices
- ⑪ Analogue third-party sensors – also with high speed functionality
- ⑫ Power supply unit with universal country-specific adaptors, strong battery power and fast charging times, energy saving options for extended operating periods
- ⑬ 2 x CAN bus networks, each with up to 24 channels
- ⑭ 2 frequency inputs or D-IN/D-OUT
- ⑮ USB device interface for connecting to a PC, laptop, etc.
- ⑯ LAN interface for remote monitoring, measured value transfer or remote control

Connection Example for Analogue Sensors / CAN Sensors



Connector for third-party sensor inputs M12 5-pin

PLUG-PPC-PAD-plus-AUX-M12A/5

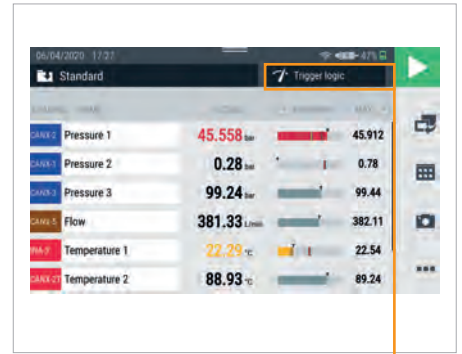
Hydraulic Tester ■ PPC-PAD-plus Display



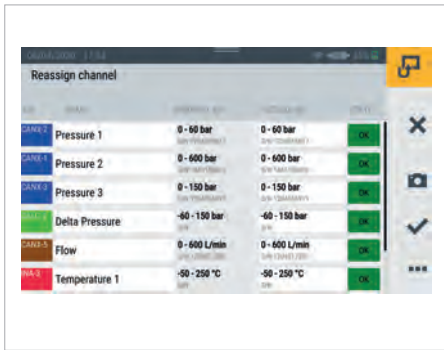
- Up to 12 channels in one display
- Colour assignment for the individual channels
- Display can be changed between ACT, MIN and MAX values



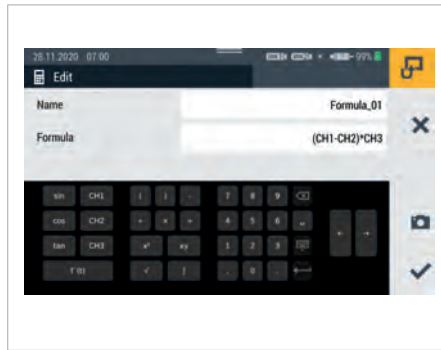
- Up to 8 freely selectable channels simultaneously in one curve display
- Choose between ACT and MIN/MAX value display
- Freely scalable
- For analysis, up to two cursors with measured value and delta value can be shown



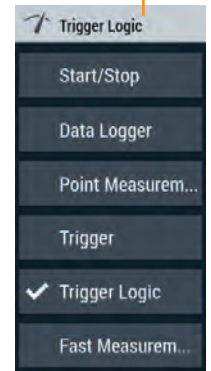
- Numerical display of 6 channels with bar chart
- Display of the measuring range, freely definable warning and alarm values (red, yellow, green) and min/max values



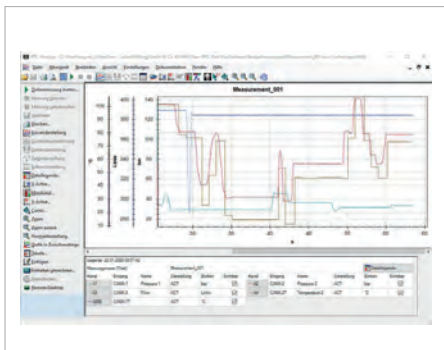
- Repeating tasks can be conveniently saved as a template
- A comparison of the preset measuring setup is also carried out when a template is selected
- Use of a template ensures comparability of the measurements
- An existing template can be duplicated and modified as required



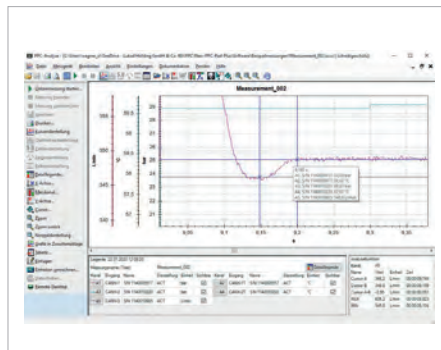
- Up to four measuring channels can be created
- In addition to the predefined standard functions such as delta values or hydraulic output, it is also possible to enter custom formulas



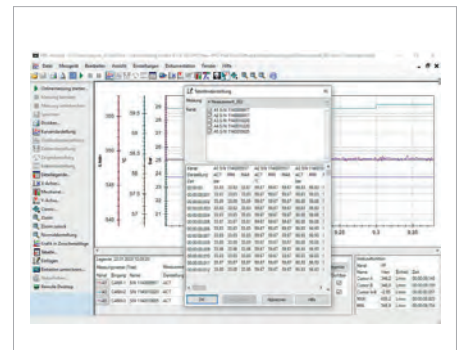
Hydraulic Tester ■ PPC-PAD-plus PC Software PPC-Analyze



The PPC-Analyze Software that is included with the tester can display, analyse and export the recorded curves.



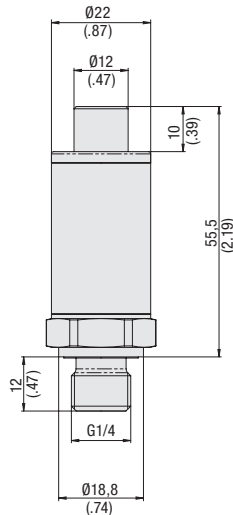
In addition, measurements can be shown on the monitor in real time using WIFI, Ethernet or USB.



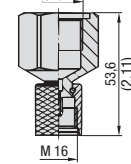
B

Pressure Sensor ■ Type Sensor-PPC-04/12-P

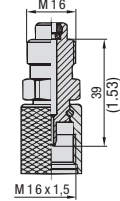
B



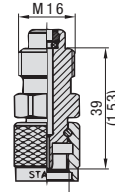
SDA-20-G1/4-W3



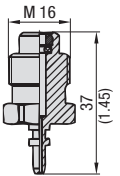
SAD-20/15-B-W3



SAD-20/12-B-W3



SAD-20/10-B-W3



Product Description

The Pressure Sensor-PPC-04/12-P can be used with all analogue Hydraulic Testers of the PPC series, due to their 5-pin connection. Due to their sturdy Stainless Steel design, the quick response times (< 1 ms) and the high accuracy ($\pm 0,25\%$ FS* typ.) with automatic sensor recognition, the Pressure Sensors are a reliable and flexible solution for the Hydraulic Testers of the PPC series.

Note: A Connection Cable-PPC-04/12-3 (3 m / 9.84 ft) is needed to connect the Pressure Sensor-PPC-04/12-P to the current Hydraulic Testers. An Extension Cable-PPC-04/12-5-EXT (5 m / 16.40 ft) is also available as an option. See page 46 for further information.

Order Codes

Sensor-PPC-04/12-P - 015 - CAL

①

②

③

① Series and Type

Pressure Sensor **Sensor-PPC-04/12-P**

② Version

See table

③ Calibration

Without calibration certificate **(none)**
With calibration certificate (factory calibration) **CAL**

Sensor-PPC-04/12-P	
Pressure Measurement	yes
Temperature Measurement	no
Process Connection	G1/4
Type	analogue 5-pin connection

Technical Data

- Sturdy Stainless Steel housing (1.4301)
- FKM (Viton®) gasket
- Weight: 85 g / .19 lbs
- Suitable for gases and liquids (in the case of aggressive media, please contact STAUFF)
- 5-pin connection
- Pressure connection G1/4 (without adaptor)

Ambient Conditions

- Media temperature: -25°C ... +105°C / -13°F ... +221°F
- Ambient temperature: -25°C ... +85°C / -13°F ... +185°F
- Rel. humidity: < 80%
- Storage temperature: -25°C ... +85°C / -13°F ... +185°F
- Load cycles (10⁶): 100

Electrical Data

- Input voltage: 9 ... 36 V DC
- Output signal: 0 ... 3 V DC
- Response time: 1 ms
- Long-term stability: < 0,2% FS* /a
- Vibration loading: acc. to IEC 60068-2-6 (20 g)
- Shock loading: acc. to IEC 60068-2-27 (50 g)

Protection Rating

- IP 54 protection rating: Dust protected and protected against splashing water

Pressure Range and Accuracies

Version	Pressure Range and Accuracies					
Sensor-PPC-04/12-P-	Pressure Measuring Range (bar/psi)	Type of Measurement	Maximum Pressure (bar/psi)	Burst Pressure (bar/psi)	Accuracy ($\pm\%$ FS*) typ.	Accuracy ($\pm\%$ FS*) max.
015	-1 ... 15	Relative pressure	30	150	0,25	0,5
	-14.5 ... 217		435	2175		
060	0 ... 60	Absolute pressure	120	500	0,25	0,5
	0 ... 870		1740	7251		
150	0 ... 150	Absolute pressure	300	900	0,25	0,5
	0 ... 2175		4351	13053		
400	0 ... 400	Absolute pressure	800	1200	0,25	0,5
	0 ... 5801		11603	17404		
600	0 ... 600	Absolute pressure	1200	1800	0,25	0,5
	0 ... 8702		17404	26106		
601	0 ... 600 **	Absolute pressure	1200	2500	0,25	0,5
	0 ... 8702		17404	36259		

* FS = Full Scale

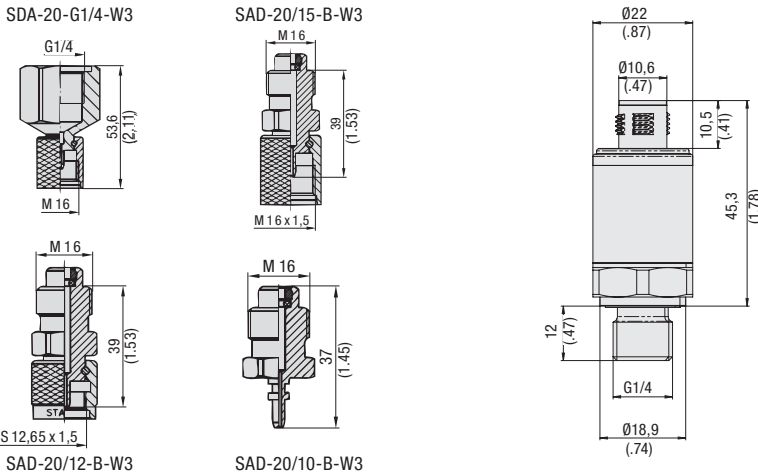
** Pressure peaks up to 1000 bar / 14503 PSI

Connection Adaptors for PPC Sensors

In addition to the Pressure Sensors, different adaptors and adaptor sets are available that not only connect to the STAUFF Test 20 (SDA-20-G1/4-W3), but also to the Test Couplings

of the STAUFF Test 15/12/10 series (SAD-20/15-B-W3, SAD-20/12-B-W3, SAD-20/10-B-W3). For further information please see Catalogue 7 - STAUFF Test.

CAN Pressure Sensor ■ Type Sensor-PPC-CAN-P



Order Codes

Sensor-PPC-CAN-P - 016 - CAL

①

②

③

① Series and Type

 CAN Pressure Sensor **Sensor-PPC-CAN-P**

② Version

See table

③ Calibration

 Without calibration certificate **(none)**
 With calibration certificate (factory calibration) **CAL**

Pressure Range and Accuracies

Version	Pressure Range and Accuracies					
Sensor-PPC-CAN-P-	Pressure Measuring Range (bar/PSI)	Type of Measurement	Maximum Pressure (bar/PSI)	Burst Pressure (bar/PSI)	Accuracy (±% FS*) typ.	Accuracy (±% FS*) max.
016	-1 ... 16	Relative pressure	32	150	0,25	0,5
	-14.5 ... 232		464	2175		
060	0 ... 60	Absolute pressure	120	500	0,25	0,5
	0 ... 870		1740	7251		
160	0 ... 160	Absolute pressure	320	900	0,25	0,5
	0 ... 2320		4641	13053		
400	0 ... 400	Absolute pressure	800	1200	0,25	0,5
	0 ... 5801		11603	17404		
600	0 ... 600	Absolute pressure	1200	1800	0,25	0,5
	0 ... 8702		17404	26106		
601	0 ... 600**	Absolute pressure	1200	2500	0,25	0,5
	0 ... 8702		17404	36259		

* FS = Full Scale

**Pressure peaks up to 1000 bar / 14503 PSI

Connection Adaptors for PPC Sensors

In addition to the CAN Pressure Sensors, different adaptors and adaptor sets are available that not only connect to the STAUFF Test 20 (SDA-20-G1/4-W3), but also to the Test

Couplings of the STAUFF Test 15/12/10 series (SAD-20/15-B-W3, SAD-20/12-B-W3, SAD-20/10-B-W3). For further information please see Catalogue 7 - STAUFF Test.

Product Description

The CAN Pressure Sensor-PPC-CAN-P are specially designed for use with the CAN Hydraulic Testers. These sensors are using the CANopen protocol to transfer the measurement values to the CAN Hydraulic Testers. Most technical details are the same as with the Pressure Sensors.

Due to their sturdy Stainless Steel design, the quick response times (< 1 ms) and the high accuracy (±0,25% FS* typ.) with automatic sensor recognition, the CAN Pressure Sensors are a reliable and flexible solution for the CAN Hydraulic Tester. The status of the sensor is indicated via LED.

Connecting the CAN Pressure Sensor to the CAN Hydraulic Tester a CAN Connection Cable and a CAN Terminating Resistor is needed. See page 47 for further information.

Sensor-PPC-CAN-P	
Pressure Measurement	yes
Temperature Measurement	no
Process Connection	G1/4
Type	CAN connection 5-pin, M12x1

Technical Data

- Sturdy Stainless Steel housing (1.4301)
- FKM (Viton®) gasket
- Sensor identification LED
- Weight: 85 g / .19 lbs
- Suitable for gases and liquids (in the case of aggressive media, please contact STAUFF)
- 5-pin connection plug
- Pressure connection G1/4 (without adaptor)

Ambient Conditions

- Media temperature: -25 °C ... +105 °C / -13 °F ... +221 °F
- Ambient temperature: -25 °C ... +85 °C / -13 °F ... +185 °F
- Rel. humidity: < 80%
- Storage temperature: -25 °C ... +85 °C / -13 °F ... +185 °F
- Load cycles (10⁶): 100

CANopen Interface

- CANopen protocol profile DS406 v3.2 with manufacturer-specific additions
- LSS service DS305 v2.0

Electrical Data

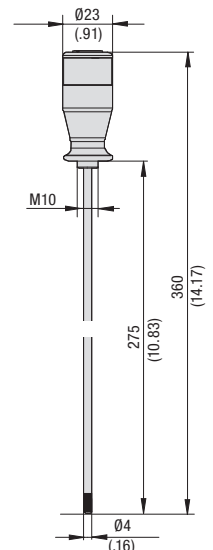
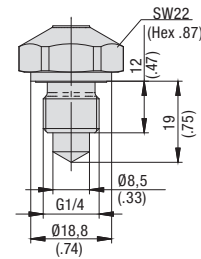
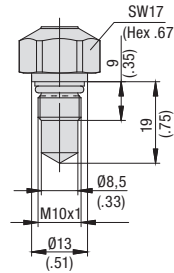
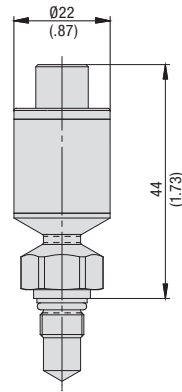
- Response time: 1 ms
- Long-term stability: < 0,2 % FS* / a
- Vibration loading: acc. to IEC 60068-2-6 (20 g)
- Shock loading: acc. to IEC 60068-2-27 (50 g)

Protection Rating

- IP 67 protection rating: Dust tight and protected against splashing water

Temperature Sensor - Type Sensor-PPC-04/12-T

B



Screw-in Temperature Sensor (T) Process Connection M10x1 Process Connection G1/4 Rod-type Temperature Sensor (TSH)

Product Description

The Screw-in Temperature Sensor-PPC-04/12-T measure current temperature directly in the pipeline and are compatible with the Flow Turbine Flow-meter-PPC-04/12-SFM and the Straight Threaded Joint SGV-16S-G-W3 (only process connection M10x1, see figure below). See product information of Flow Turbine on page 42.

The Rod-type Temperature Sensor-PPC-04/12-TSH is especially designed to determine the media temperatures in tanks and containers.

Note: A Connection Cable-PPC-04/12-3 (3 m / 9.84 ft) is needed to connect the Temperature Sensor-PPC-04/12-T or -TSH to the current Hydraulic Testers. An Extension Cable-PPC-04/12-5-EXT (5 m / 16.40 ft) is also available as an option. See page 46 for further information.

Sensor-PPC-04/12-T	
Pressure Measurement	no
Temperature Measurement	yes
Process Connection	M10x1 or G1/4
Type	analogue 5-pin connection

Sensor-PPC-04/12-T-M02 with SGV-16S-G-W3

For further information please see Catalogue 7 - STAUFF Test.



Order Codes

Sensor-PPC-04/12 - T - M02 - CAL

①

②

③

④

① Series and Type

Temperature Sensor **Sensor-PPC-04/12**

② Version

Screw-in **T**
Rod-type **TSH**

③ Process Connection (only for Version T)

M10x1 **M02**
G1/4 **B04**

④ Calibration

Without calibration certificate **(none)**
With calibration certificate (factory calibration) **CAL**

Technical Data

- Suitable for liquids (in the case of aggressive media please contact STAUFF)
- 5-pin connection

Materials

- Housing (T): Stainless Steel
- Gaskets (T): FKM (Viton®)
- Rod (TSH): Stainless Steel 1.4304
- Handle (TSH): Delrin

Weight

- Screw-in (T)
M02 (M10x1): 70 g / .15 lbs
B04 (G1/4): 55 g / .12 lbs
- Rod-type (TSH): 120 g / .26 lbs

Connection

- STAUFF Test connection SGV-16S-G-W3 in the pipeline (only M10x1)
- Screw-in thread (T): M10x1 or G1/4 (see figure)
- Screw-in thread (TSH): M10

Ambient Conditions (Screw-in Temperature Sensor)

- Media temperature: -40°C ... +150°C / -40°F ... +302°F
- Ambient temperature: -40°C ... +85°C / -40°F ... +185°F
- Storage temperature: -40°C ... +85°C / -40°F ... +185°F

Ambient Conditions (Rod-type Temperature Sensor)

- Media temperature: -25°C ... +125°C / -13°F ... +257°F
- Ambient temperature: -25°C ... +70°C / -13°F ... +158°F
- Storage temperature: -25°C ... +80°C / -13°F ... +176°F
- Rel. humidity: < 80%

Measuring Range

- Measuring range (T): -40°C ... +150°C / -40°F ... +302°F
- Measuring range (TSH): -25°C ... +125°C / -13°F ... +257°F
- Operating pressure (T): 630 bar / 9137 PSI
- Maximum pressure (T): 800 bar / 11603 PSI
- Burst pressure (T): 2150 bar / 31183 PSI
- Accuracy: ±1 % FS

Electrical Data

- Input signal: 7 ...12 V DC
- Output signal: 0 ...3 V DC
- Response time (T)
M02 (M10x1): $T_{90} \leq 4$ s, $T_{95} \leq 14$ s
B04 (G1/4): $T_{90} \leq 4$ s, $T_{95} \leq 12$ s
- Response time (TSH): $T_{90} \leq 9,1$ s
- Vibration loading: acc. to IEC 60068-2-6 (20 g)
- Shock loading: acc. to IEC 60068-2-27 (50 g)

Protection Rating

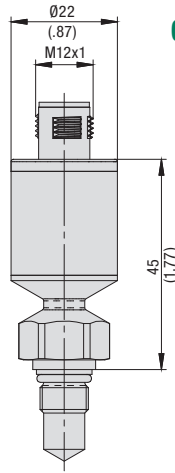
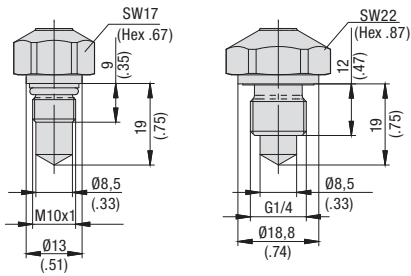
- IP 54 protection rating: Dust protected and protected against splashing water

* FS = Full Scale

Dimensional drawings: All dimensions in mm (in).

CAN Temperature Sensor ■ Type Sensor-PPC-CAN-T

B



Process Connection M10x1

Process Connection G1/4

Order Codes

Sensor-PPC-CAN - T - M02 - CAL

①

②

③

④

① Series and Type

 CAN Temperature Sensor **Sensor-PPC-CAN**

② Version

 Screw-in **T**

③ Process Connection (only for Version T)

 M10x1 **M02**
 G1/4 **B04**

④ Calibration

 Without calibration certificate **(none)**
 With calibration certificate (factory calibration) **CAL**

Technical Data

- Suitable for liquids
(in the case of aggressive media please contact STAUFF)
- 5-pin connection plug
- Sensor identification LED

Materials

- Housing: Stainless Steel
- Gaskets: FKM (Viton®)

Weight

- M02 (M10x1): 70 g / .15 lbs
- B04 (G1/4): 55 g / .12 lbs

Ambient Conditions

- Media temperature: -40 °C ... +150 °C / -40 °F ... +302 °F
- Ambient temperature: -40 °C ... +85 °C / -40 °F ... +185 °F
- Storage temperature: -40 °C ... +85 °C / -40 °F ... +185 °F
- Rel. humidity: < 80%

Measuring Range

- Measuring range: -40 °C ... +150 °C / -40 °F ... +302 °F
- Operating pressure: 630 bar / 9137 PSI
- Maximum pressure: 800 bar / 11603 PSI
- Burst pressure: 2150 bar / 31183 PSI
- Accuracy: ±0,66 % FS

CANopen Interface

- CANopen protocol profile DS301, Typ 2.0A
with manufacturer-specific additions
- LSS service DS305 v2.0

Electrical Data

- Output signal: CAN bus
- Response time
M02 (M10x1): $T_{50} \leq 4 \text{ s}, T_{90} \leq 12 \text{ s}$
B04 (G1/4): $T_{50} \leq 4 \text{ s}, T_{90} \leq 14 \text{ s}$
- Vibration loading: acc. to IEC 60068-2-6 (20 g)
- Shock loading: acc. to IEC 60068-2-27 (50 g)

Protection Rating

- IP 67 protection rating: Dust tight and protected against splashing water

Product Description

The CAN Temperature Sensor-PPC-CAN-T are specially designed for use with the CAN Hydraulic Testers. This sensor is using the CANopen protocol to transfer the measurement values to the CAN Hydraulic Testers. The Sensor-PPC-CAN-T is compatible with the CAN Flow Turbine Flow-meter-PPC-CAN-SFM and the Straight Threaded Joint SGV-16S-G-W3 (only process connection M10x1, see figure below). See product information of CAN Flow Turbine on page 43.

Most technical details are the same as with the Temperature Sensor-PPC-04/12-T.

Due to their sturdy Stainless Steel design with automatic sensor recognition, the CAN Temperature Sensor is a reliable and flexible solution for the CAN Hydraulic Tester. The status of the sensor is indicated via LED.

Connecting the CAN Temperature Sensor to the CAN Hydraulic Tester a CAN Connection Cable and a CAN Terminating Resistor is needed. See page 47 for further information.

Sensor-PPC-CAN-T	
Pressure Measurement	no
Temperature Measurement	yes
Process Connection	M10x1 or G1/4
Type	CAN connection 5-Pin, M12x1

Sensor-PPC-CAN-T-M02 with SGV-16S-G-W3

For further information please see Catalogue 7 - STAUFF Test.

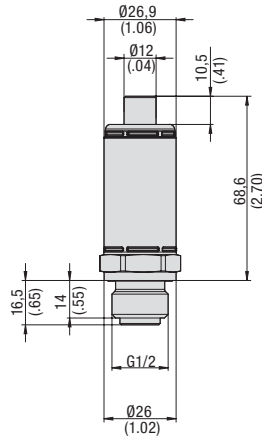


* FS = Full Scale

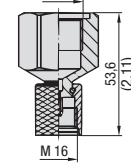
Dimensional drawings: All dimensions in mm (in).

Pressure / Temperature Sensor ▪ Type Sensor-PPC-04/12-PT

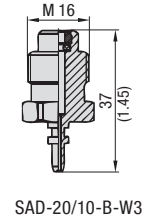
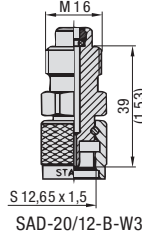
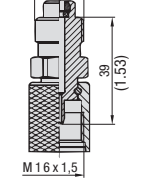
B



SDA-20-G1/2-W3



SAD-20/15-B-W3



Product Description

The Pressure / Temperature Sensor-PPC-04/12-PT can be used with all Hydraulic Testers of the PPC series, due to the 5-pin connection. This sensor is able to measure and display temperatures on the Hydraulic Testers.

Due to their sturdy Stainless Steel design, the quick response time (< 1 ms) and the high accuracy ($\pm 0,25\%$ FS* typ.) with automatic sensor recognition, the Pressure / Temperature Sensor is a reliable and flexible solution for the Hydraulic Testers of the PPC series.

Note: A Connection Cable-PPC-04/12-3 (3 m / 9.84 ft) is needed to connect the Pressure / Temperature Sensor to the current Hydraulic Testers. An Extension Cable-PPC-04/12-5-EXT (5 m / 16.40 ft) is also available as an option. See page 46 for further information.

Sensor-PPC-04/12-PT-	
Pressure Measurement	yes
Temperature Measurement	yes
Process Connection	G1/2
Type	analogue 5-pin connection

Technical Data

- Sturdy Stainless Steel housing (1.4301)
- FKM (Viton®) gasket
- Weight: 200 g / .44 lbs
- Suitable for gases and liquids (in the case of aggressive media, please contact STAUFF)
- 5-Pin connection
- Pressure connection G1/2 (without adaptor)

Ambient Conditions

- Media temperature: -25 °C ... +105 °C / -13 °F ... +221 °F
- Ambient temperature: -25 °C ... +85 °C / -13 °F ... +185 °F
- Rel. humidity: < 80%
- Storage temperature: -25 °C ... +85 °C / -13 °F ... +185 °F
- Compensated range: 0 °C ... +85 °C / +32 °F ... +285 °F
- Load cycles (10⁶): 100

Electrical Data

- Input voltage: 7 ... 12 V DC
- Output signal: 0 ... 3 V DC
- Response time: 1 ms
- Long-term stability: < 0,2 % FS* /a
- Vibration loading: acc. to IEC 60068-2-6 (20g)
- Shock loading: acc. to IEC 60068-2-27 (50g)

Protection Rating

- IP 54 protection rating: Dust protected and protected against splashing water

Order Codes

Sensor-PPC-04/12-PT - 015/2 - CAL

①

②

③

① Series and Type

Pressure / Temperature Sensor **Sensor-PPC-04/12-PT**

② Version

See table

③ Calibration

Without calibration certificate **(none)**
With calibration certificate (factory calibration) **CAL**

Pressure Range and Accuracies

Version	Pressure Range and Accuracies		Maximum Pressure	Burst Pressure	Accuracy	Accuracy	Temperature Measuring Range	Accuracy
Sensor-PPC-04/12-PT-	Pressure Measuring Range (bar/PSI)	Type of Measurement	(bar/PSI)	(bar/PSI)	(±% FS*) typ.	(±% FS*) max.	(°C/°F)	(±% FS*)
015/2	-1 ... 15	Relative pressure	30	150	0,25	0,5	-25 ... 105	1,5
	-14,5 ... 217		435	2175				
060/2	0 ... 60	Absolute pressure	120	500	0,25	0,5	-25 ... 105	1,5
	0 ... 870		1740	7251				
150/2	0 ... 150	Absolute pressure	300	900	0,25	0,5	-25 ... 105	1,5
	0 ... 2175		4351	13053				
400/2	0 ... 400	Absolute pressure	800	1200	0,25	0,5	-25 ... 105	1,5
	0 ... 5801		11603	17404				
600/2	0 ... 600	Absolute pressure	1200	1800	0,25	0,5	-25 ... 105	1,5
	0 ... 8702		17404	26106				
601/2	0 ... 600 **	Absolute pressure	1200	2500	0,25	0,5	-25 ... 105	1,5
	0 ... 8702		17404	36259				

* FS = Full Scale

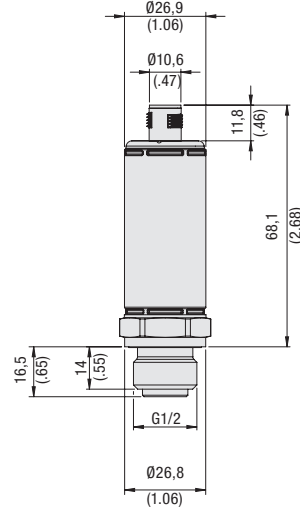
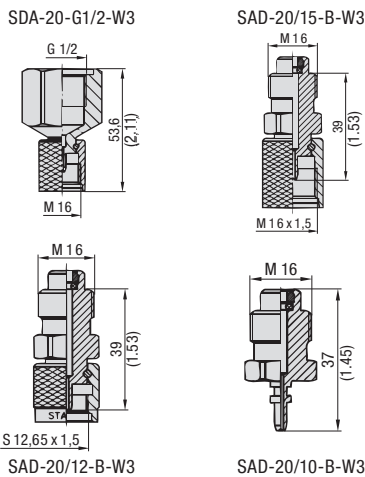
** Pressure peaks up to 1000 bar / 14503 PSI

Connection Adaptors for PPC Sensors

In addition to the Pressure / Temperature Sensors, different adaptors and adaptor sets are available that not only connect to the STAUFF Test 20 (SDA-20-G1/2-W3), but also to the Test

Couplings of the STAUFF Test 15/12/10 series (SAD-20/15-B-W3, SAD-20/12-B-W3, SAD-20/10-B-W3). For further information please see Catalogue 7 - STAUFF Test.

CAN Pressure / Temperature Sensor - Type Sensor-PPC-CAN-PT



Product Description

The CAN Pressure / Temperature Sensor-PPC-CAN-PT is specially designed for use with the CAN Hydraulic Testers. This sensor is using the CANopen protocol to transfer the measurement values to the CAN Hydraulic Testers. Most technical details are the same as with the Pressure / Temperature Sensor-PPC-04/12-PT. The CAN sensor is able to measure and display temperatures on the CAN Hydraulic Testers.

Due to their sturdy Stainless Steel design, the quick response time (< 1 ms) and the high accuracy ($\pm 0.25\%$ FS* typ.) with automatic sensor recognition, the pressure / temperature sensor is a reliable and flexible solution for the CAN Hydraulic Tester. The status of the sensor is indicated via LED.

Connecting the CAN Pressure / Temperature Sensor to the CAN Hydraulic Tester a CAN Connection Cable and a CAN Terminating Resistor is needed. See page 47 for further information.

PPC-CAN-PT	
Pressure Measurement	yes
Temperature Measurement	yes
Process Connection	G1/2
Type	CAN connection 5-pin, M12x1

Technical Data

- Sturdy Stainless Steel housing (1.4301)
- FKM (Viton®) gasket
- Sensor identification LED
- Weight: 200 g / .44 lbs
- Suitable for gases and liquids (in the case of aggressive media, please contact STAUFF)
- 5-pin connection plug
- Pressure connection G1/2 (without adaptor)

Ambient Conditions

- Media temperature: -25 °C ... +105 °C / -13 °F ... +221 °F
- Ambient temperature: -25 °C ... +85 °C / -13 °F ... +185 °F
- Rel. humidity: < 80%
- Storage temperature: -25 °C ... +85 °C / -13 °F ... +185 °F
- Compensated range: 0 °C ... +85 °C / +32 °F ... +185 °F
- Load cycles (10⁶): 100

CANopen Interfaces

- CANopen protocol profile DS406 v3.2 with manufacturer-specific additions
- LSS service DS305 v2.0

Electrical Data

- Response time: 1 ms
- Vibration loading: acc. to IEC 60068-2-6 (20g)
- Shock loading: acc. to IEC 60068-2-27 (50g)

Protection Rating

- IP 67 protection rating: Dust tight and protected against splashing water

Order Codes

Sensor-PPC-CAN-PT - 016 - CAL

①

②

③

① Series and Type

CAN Pressure / Temperature Sensor **Sensor-PPC-CAN-PT**

② Version

See table

③ Calibration

Without calibration certificate **(none)**
With calibration certificate (factory calibration) **CAL**

Pressure Range and Accuracies

Version	Pressure Range and Accuracies							
Sensor-PPC-CAN-PT-	Pressure Measuring Range (bar/psi)	Type of Measurement	Maximum Pressure (bar/psi)	Burst Pressure (bar/psi)	Accuracy ($\pm\%$ FS*) typ.	Accuracy ($\pm\%$ FS*) max.	Temperature Measuring Range (°C/°F)	Accuracy ($\pm\%$ FS*)
016	-1 ... 16	Relative pressure	32	150	0,25	0,5	-25 ... 105	$\pm 2K$ typ./
	-14.5 ... 232		464	2175			-13 ... 221	$\pm 3K$ max.
060	0 ... 60	Absolute pressure	120	500	0,25	0,5	-25 ... 105	$\pm 2K$ typ./
	0 ... 870		1740	7251			-13 ... 221	$\pm 3K$ max.
160	0 ... 160	Absolute pressure	320	900	0,25	0,5	-25 ... 105	$\pm 2K$ typ./
	0 ... 2320		4641	13053			-13 ... 221	$\pm 3K$ max.
400	0 ... 400	Absolute pressure	800	1200	0,25	0,5	-25 ... 105	$\pm 2K$ typ./
	0 ... 5801		11603	17404			-13 ... 221	$\pm 3K$ max.
600	0 ... 600	Absolute pressure	1200	1800	0,25	0,5	-25 ... 105	$\pm 2K$ typ./
	0 ... 8702		17404	26106			-13 ... 221	$\pm 3K$ max.
601	0 ... 600**	Absolute pressure	1200	2500	0,25	0,5	-25 ... 105	$\pm 2K$ typ./
	0 ... 8702		17404	36259			-13 ... 221	$\pm 3K$ max.

* FS = Full Scale

** Pressure peaks up to 1000 bar / 14503 PSI

Connection Adaptors for PPC Sensors

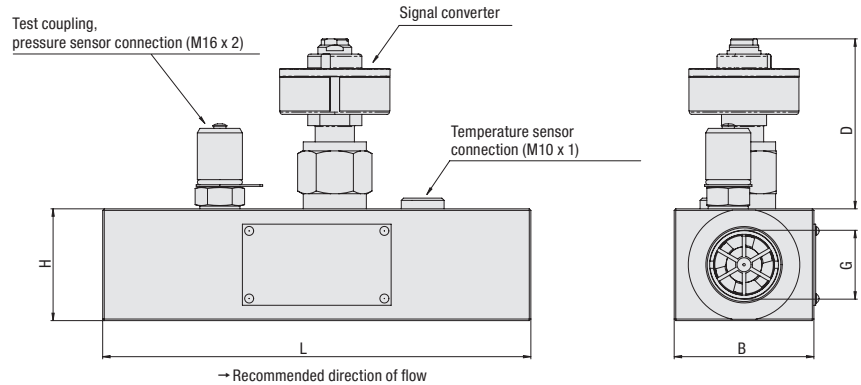
In addition to the CAN Pressure / Temperature Sensors, different adaptors and adaptor sets are available that not only connect to the STAUFF Test 20 (SDA-20-G1/2-W3), but also to the Test Couplings of the STAUFF Test 15/12/10 series

(SAD-20/15-B-W3, SAD-20/12-B-W3, SAD-20/10-B-W3). For further information please see Catalogue 7 - STAUFF Test.

Dimensional drawings: All dimensions in mm (in).

Flow Turbine ▪ Type Flow-meter-PPC-04/12-SFM

B



Product Description

The Flow-meter-PPC-04/12-SFM Flow Turbine is permanently installed in the pipeline. The oil flow rotates the internal axial turbine. The frequencies generated are processed by digital electronics (a signal converter). Interferences caused by flow effects are compensated by this process. The signal converter is now directly integrated into the Flow Turbine. This allows even simpler operation and supports permanent coupling of the turbine and signal converter components that are matched to one another.

The Flow Turbine also improves the response time (from previously 400 ms to 50 ms) and increases the measuring accuracy.

The Flow-meter-PPC-04/12-SFM is available in five versions for various flow speeds. A Pressure Sensor-PPC-04/12-P (see page 36) can be connected in parallel to the Flow Turbine by way of the integrated test coupling. In addition, the oil temperature can also be measured using the connection of the Temperature Sensor-PPC-04/12-T (see page 38).

In general, the Flow Turbine can handle flows in either direction. The specified technical data and the calibration (available as an option) apply only when the flow through the Flow Turbine matches the recommended flow direction. A double-headed arrow is shown on the nameplate of the Flow-meter-PPC-04/12-SFM. The thicker end of the double-headed arrow specifies the recommended direction of flow.

Note: A Connection Cable-PPC-04/12-3 (3 m / 9.84 ft) is needed to connect the Flow Turbine to the current Hydraulic Testers. An Extension Cable-PPC-04/12-5-EXT (5 m / 16.40 ft) is also available as an option. See page 46 for further information.

Order Codes

Flow-meter-PPC-04/12 - SFM-015 - CAL

① Series and Type

Flow Turbine **Flow-meter-PPC-04/12**

② Version

1 ... 15 l/min / .27 ... 3.90 US GPM	SFM-015
3 ... 60 l/min / .79 ... 15.90 US GPM	SFM-060
5 ... 150 l/min / 1.32 ... 39.60 US GPM	SFM-150
8 ... 300 l/min / 2.11 ... 79.00 US GPM	SFM-300
15 ... 600 l/min / 3.96 ... 158.00 US GPM	SFM-600

③ Calibration

Without calibration certificate **(none)**
 With calibration certificate (factory calibration) **CAL**

UNF version available on request.

Technical Data

Materials

- Housing: Aluminium (black anodised)
- Gaskets: FKM (Viton®)
- 5-pin connection
- Pressure measurement connection: SMK-20 (M16 x 2)
- Temperature measurement connection: M10 x 1 (standard screw plug)

Electrical Data

- Response time: 50 ms

Process Connection

- Please see table below

Protection Rating

- IP 54 protection rating: Dust protected and protected against splashing water

Ambient Conditions

- Media temperature: -20 °C ... +90 °C / -4 °F ... +194 °F
- Ambient temperature: -10 °C ... +50 °C / +14 °F ... +122 °F
- Storage temperature: -20 °C ... +80 °C / -4 °F ... +176 °F
- Rel. humidity: < 80%
- Permissible particle size: <10 Micron for SFM-015, <25 Micron for others
- Viscosity range: 10 ... 100 cSt

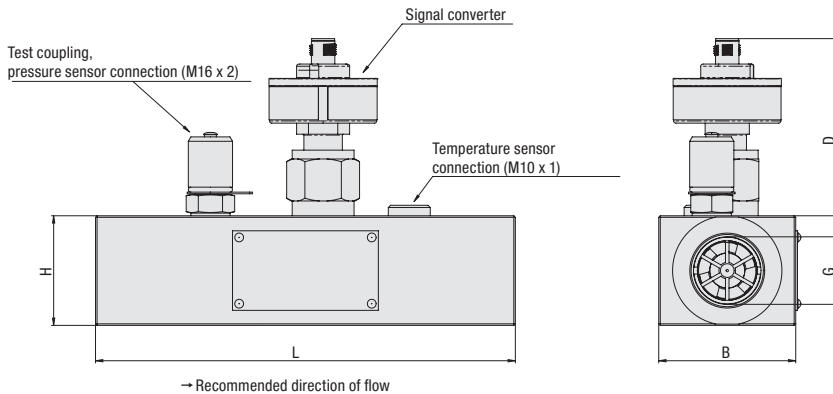
Dimensions and Measuring Range

Version	Measuring Range						Dimensions (mm/in)						Weight (kg/lbs)
	Measuring Range (l/min / US GPM)	Max. Flow (l/min / US GPM)	Operating Pressure (bar / PSI)	Max. Pressure (bar / PSI)	Accuracy (at 21 cSt)	Max. Pressure Drop (at FS*) (bar / PSI)	G ** (BSP)	G (UNF)	B	D	L	H	
SFM-015	1 ... 15	16.5	350	420	±1 (% FS*)	1.5	G1/2	3/4-16	37	71	136	37	650
	.27 ... 3.90	4.4	5076	6091		21.8			1.46	2.80	5.35	1.46	1.4
SFM-060	3 ... 60	66	350	420	±1 (% of the displayed value)***	1.5	G3/4	1-1/16-16	62	72	190	50	750
	.79 ... 15.90	17.4	5076	6091		21.8			2.44	2.83	7.48	1.97	1.6
SFM-150	5 ... 150	165	350	420	±1 (% of the displayed value)***	1.5	G3/4	1-1/16-16	62	72	190	50	750
	1.32 ... 39.60	43.6	5076	6091		21.8			2.44	2.83	7.48	1.97	1.6
SFM-300	8 ... 300	330	350	420	±1 (% of the displayed value)***	4	G1	1-5/16-16	62	76	190	50	1200
	2.11 ... 79.00	87.2	5076	6091		58			2.44	2.99	7.48	1.97	2.6
SFM-600	15 ... 600	660	290	348	±1 (% of the displayed value)***	5	G1-1/4	1-5/8-12	62	66	212	75	1800
	3.96 ... 158.00	174.4	4206	5047		72.5			2.44	2.60	8.35	2.95	4

* FS = Full Scale

** Standard option *** for measured values ≥ 15% FS; for measured values < 15% FS accuracy 0.15% FS
 Dimensional drawings: All dimensions in mm (in).

CAN Flow Turbine ■ Type Flow-meter-PPC-CAN-SFM



Order Codes

Flow-meter-PPC-CAN - SFM-015 - CAL

①

②

③

① Series and Type

 CAN Flow Turbine **PPC-CAN**

② Version

1 ... 15 l/min / .27 ... 3.90 US GPM	SFM-015
3 ... 60 l/min / .79 ... 15.90 US GPM	SFM-060
5 ... 150 l/min / 1.32 ... 39.60 US GPM	SFM-150
8 ... 300 l/min / 2.11 ... 79.00 US GPM	SFM-300
15 ... 600 l/min / 3.96 ... 158.00 US GPM	SFM-600

③ Calibration

 Without calibration certificate **(none)**
 With calibration certificate (factory calibration) **CAL**
UNF version available on request.

Technical Data

Materials

- Housing: Aluminium (black anodised)
- Gaskets: FKM (Viton®)
- 5-pin connection plug
- Pressure measurement connection: SMK-20 (M16 x 2)
- Temperature measurement connection: M10 x 1 (standard screw plug)

Ambient Conditions

- Media temperature: -20 °C ... +90 °C / -4 °F ... +176 °F
- Ambient temperature: -10 °C ... +50 °C / +14 °F ... +122 °F
- Storage temperature: -20 °C ... +80 °C / -4 °F ... +176 °F
- Rel. humidity: < 80%
- Permissible particle size: <10 Micron for SFM-015 (CAN), <25 Micron for others
- Viscosity range: 10 ... 100 cSt

Electrical Data

- Response time: 50 ms

Process Connection

- Please see table below

Protection Rating

- IP 66 protection rating: Dust protected and protected against strong jets of water

Product Description

The CAN Flow Turbine Flow-meter-PPC-CAN-SFM is specially designed for the use with the CAN Hydraulic Testers and has to be installed permanently in the pipeline where the oil flow rotates the internal axial turbine. The generated frequencies are processed by digital electronics (a signal converter). Interferences caused by flow effects are compensated by this process. The signal converter is now directly integrated into the CAN Flow Turbine. This allows even simpler operation and supports permanent coupling of the turbine and signal converter components that are matched to one another.

The CAN Flow Turbine also improves the response times/ reaction times (from a previous 400 ms to 50 ms) and increases measurement accuracy.

The CAN Flow Turbine is available in five versions for various flow speeds. A CAN Pressure Sensor-PPC-CAN-P (see page 37) can be connected parallel to the CAN Flow Turbine by the way of the integrated test coupling. In addition, the oil temperature can also be measured using the connection of the Temperature Sensor-PPC-CAN-T (see page 39).

In general, the CAN Flow Turbine can handle flows in either direction. The specified technical data and the calibration (available as an option) apply only when the flow through the CAN Flow Turbine matched the recommended flow direction. A double-headed arrow is shown on the nameplate of the Flow-meter-PPC-CAN-SFM. The thicker end of the double-headed arrow specifies the recommended direction of the flow.

Connecting the CAN Flow Turbine to the CAN Hydraulic Tester a CAN Connection Cable and a CAN Terminating Resistor is needed. See page 47 for further information.

Dimensions and Measuring Range

Version	Measuring Range						Dimensions (mm/in)						
	Measuring Range (l/min / US GPM)	Max. Flow (l/min / US GPM)	Operating Pressure (bar / PSI)	Max. Pressure (bar / PSI)	Accuracy (at 21 cSt)	Max. Pressure Drop (at FS*) (bar / PSI)	G ** (BSP)	G (UNF)	B	D	L	H	Weight (kg / lbs)
SFM-015	1 ... 15	16,5	350	420	±1 (% FS*)	1,5	G1/2	3/4-16	37	78,8	136	37	650
	.26 ... 3.90	4.4	5076	6091		21.8			1.46	3.10	5.35	1.46	1.43
SFM-060	3 ... 60	66	350	420	±1 (% of the displayed value)***	1,5	G3/4	1-1/16-16	62	79,4	190	50	750
	.79 ... 15.90	17.4	5076	6091		21.8			2.44	3.13	7.48	1.97	1.65
SFM-150	5 ... 150	165	350	420	±1 (% of the displayed value)***	1,5	G3/4	1-1/16-16	62	79,4	190	50	750
	1.32 ... 39.60	43.6	5076	6091		21.8			2.44	3.13	7.48	1.97	1.65
SFM-300	8 ... 300	330	350	420	±1 (% of the displayed value)***	4	G1	1-5/16-16	62	81,3	190	50	1200
	2.11 ... 79.00	87.2	5076	6091		58			2.44	3.20	7.48	1.97	2.65
SFM-600	15 ... 600	660	290	348	±1 (% of the displayed value)***	5	G1-1/4	1-5/8-12	62	76,2	212	75	1800
	3.96 ... 158.00	174.4	4206	5047		72.5			2.44	3	8.35	2.95	3.97

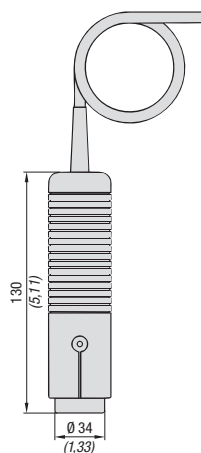
* FS = Full Scale

** Standard option *** for measured values ≥ 15% FS; for measured values < 15% FS accuracy 0.15% FS

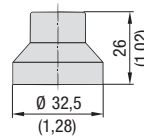
Dimensional drawings: All dimensions in mm (in).

Rotational Speed Sensor ■ Type Sensor-PPC-04/12-SDS-CAB

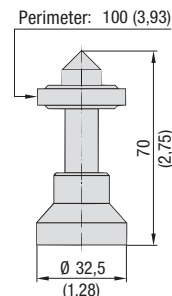
B



Sensor-PPC-04/12-SDS-CAB



Adaptor-PPC-04/12-SFA-Focus



Adaptor-PPC-04/12-SKA-Contact

Product Description

The Sensor-PPC-04/12-SDS-CAB Rotational Speed Sensor allows non-contact speed measurement of rotating components. The sensor is based on an opto-electrical measurement principle that determines the rotational speed with high-accuracy using a reflecting strip on the shaft.

The contact rotational speed measurement is obtained by using a Contact Adaptor that is mounted to the sensor, and which makes contact with the rotating component during measurement.

This also produces high-accuracy measurement results. In the case of especially small areas, using the focusing adaptor facilities measurement.

Note: The analogue Rotational Speed Sensor-PPC-04/12-SDS-CAB can only be used with analogue Hydraulic Testers.

Technical Data

- Material: ABS
- Weight: 230 g / .51 lbs
- 5-pin connection
- Both contacting and non-contacting measurement possible
- Type of measurement: optical, red LED

Ambient Conditions

- Ambien temperature: 0°C ... +70 °C / +32°F ... +158 °F
- Rel. humidity: < 80%

Measuring Range

- Measuring range: 20 ... 10000 1/min
- Measuring distance: 25 ... 500 mm (1 ... 20 in)
- Measuring angle: ±45 °C
- Accuracy: ≤ ±0,5 % FS*
- Resolution: ±5 1/min

Electrical Data

- Output signal: 0 ... 3 V DC
- Input signal: 7 ...12 V DC

Note: We recommended not extending the 3 m / 9.84 ft permanent cable connection provided on the sensor!

Order Codes

Sensor-PPC-04/12-SDS-CAB - CAL

①

②

① Series and Type

Rotational Speed Sensor

Sensor-PPC-04/12-SDS-CAB

② Calibration

Without calibration certificate

(none)

With calibration certificate (factory calibration)

CAL

Order Codes

Focus Adaptor

Adaptor-PPC-04/12-SFA-focus

①

① Series and Type

Focus Adaptor

Adaptor-PPC-04/12-SFA-focus

Contact Adaptor

Adaptor-PPC-04/12-SKA-contact

①

① Series and Type

Contact Adaptor

Adaptor-PPC-04/12-SKA-contact

Applications Examples

Fig. 1 -

Contacting rotational speed measurement with the contact adaptor

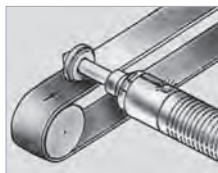


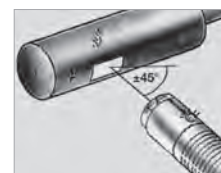
Fig. 2 -

End face rotational speed measurement with the contact adaptor

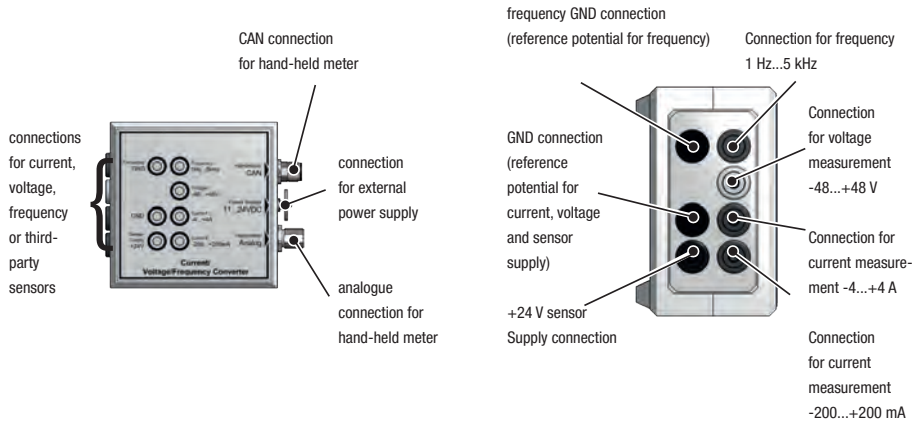


Fig. 3 -

Rotating shaft / non-contacting rotational speed measurement using the focusing adaptor and marking strip



Current/Voltage/Frequency Converter ■ Type Sensorconverter-PPC



B

Order Codes

Sensorconverter-PPC

①

① Series and Type

Current/Voltage/Frequency Converter

Sensorconverter-PPC

Analogue Signal Measurement

Measuring of electric signals from a third-party sensor (e.g. 4 – 20 mA, 0 – 10 V) with the Sensorconverter-PPC.

The Sensorconverter-PPC is used, for example, for to measure the current consumption on proportional valves or for determining the switching statuses of motors or pumps. This allows the PPC testers to read these third-party sensors. Typical applications for generating and measuring a force/displacement diagram or torque/volumetric flow characteristic curves.

The following input signals can be processed:

- Voltage (DC) -48 V...+48 V
CAN: $\pm 0.5\%$ FS;
Analogue: $\pm 1\%$ FS
- Current (DC) -200 mA...+200 mA
CAN: $\pm 0.5\%$ FS;
Analogue: $\pm 1\%$ FS
- Current (DC) -4...+4 A
 $\pm 1.5\%$ FS
- Long term stability 0.1% span/a

Frequency Signal Measurement

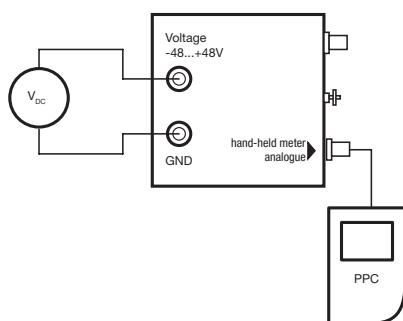
Measuring of electric frequencies from a third-party sensor

The Sensorconverter-PPC is used to make frequency signals (e.g. from turbine flow meters, volumetric flow meters and speedometers) measurable for PPC Hydraulic Testers. The adaptor can process sinusoidal and square signals from 1 Hz to 5 kHz with amplitudes from 100 mV to 24 V.

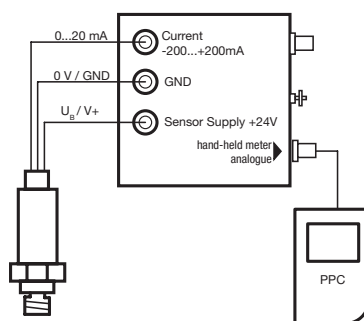
The following input signals can be processed:

- Frequency 1...5000 Hz; 100 mV...24 V
CAN: $\pm 0.1\%$ FS @ < 100 Hz
CAN: $\pm 0.5\%$ FS @ > 100 Hz
Analogue: $\pm 1\%$
- Long term stability 0.1% span/a

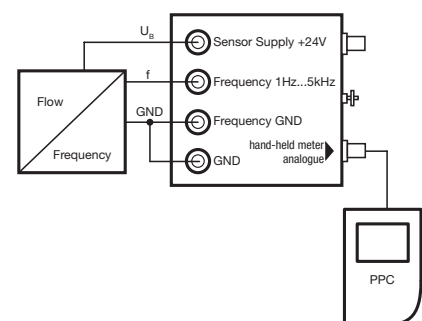
Connection example for voltage measurement



Connection example for pressure sensor 600 bar, 0...20 mA



Connection example for flow meter 160 l/min, 1 kHz



The measured data are transferred to the Hydraulic Testers directly with the normal CAN or analogue Connection Cables.

Product Description

The PPC Sensor Converter offers users the option of connecting third party sensors to the PPC Hydraulic Tester which are not equipped with a STAUFF sensor detection. These can have different output levels and can therefore also be easily measured with the Hydraulic Tester.

Specifications

- Dimensions: 100x100x61 mm
- Material: ABS
- Weight: 240 g
- Operating temperature 0...+60 °C
- Storage temperature -20...+85 °C
- Rel. humidity < 80 %
- Protection rating IP40 (EN 60529)

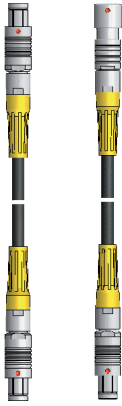
External power supply

- Power supply 11...30 V DC

Power supply for third-party sensor (galvanically isolated)

- Voltage 24 V DC ± 2 V
- Current without PSU max. 50 mA
- Current with PSU max. 100 mA

Connection and Extension Cables (analogue)



Connection Cable-PPC-04/12-3
 Extension Cable-PPC-04/12-5-EXT

B

Product Description

Different Connection and Extension Cables for all Hydraulic Testers of the PPC series are available. These cables on the one hand, connect the sensors to the Hydraulic Testers and on the other hand connect the Hydraulic Testers with a PC or laptop. The following items are available:

Connection and Extension Cables

A Cable-PPC-04/12-3 Connection Cable is required to connect the sensors to the current Hydraulic Testers PPC-04/06/08-plus or PPC Pad. The cable comes with a 5-pin push/pull connection at each end and has a length of 3 m / 9.84 ft.

Note: This cable cannot be used with older Hydraulic Testers and/or sensors (with 4-pin connection)! The Cable-PPC-04/12-5-EXT Exentsion Cable has a length of 5 m/16 ft.

Note: Please keep in mind that it is generally recommended not to exceed a total cable length of 8 m / 26.25 ft!

Order Codes

Cable-PPC-04/12-3

①

① Series and Type

Standard Connection	Cable-PPC-04/12-3
Cable for Sensors	Cable-PPC-04/12-3
Extension Cable	Cable-PPC-04/12-5-EXT



CAN Connection Cable-PPC-CAN-CAB



CAN Y-Splitter Cable-PPC-CAN-CAB-Y



CAN Terminating Resistor-PPC-CAN

Product Description

To connect the CAN bus sensors to the CAN Hydraulic Testers are different cable lengths are available, depending on customers requirements. The CAN sensors work on a bus system as displayed in the connection overview on page 27. All connections are 5-pin connection plugs. The following items are available:

CAN Connection Cable

The CAN Connection Cable is available in different lengths between 0,5 m / 1.64 ft and 20 m / 65.62 ft.

CAN Y-Splitter Cable

To connect a new sensor to the CAN bus, a CAN Y-Splitter Cable is necessary.

CAN Terminating Resistor

Each sensor on the end of a CAN bus has to be closed with a CAN Terminating Resistor. The resistor is also necessary when only one sensor is used.

Order Codes

Cable-PPC-CAN - 2

① ②

① Series and Type

CAN Connection Cable **Cable-PPC-CAN**

② Length

0,5 m / 1.64 ft	0.5
2 m / 6.65 ft	2
5 m / 16.40 ft	5
10 m / 32.81 ft	10

Order Code

Cable-PPC-CAN-Y

①

① Series and Type

CAN Y-Splitter Cable 0,3 m / .98 ft **Cable-PPC-CAN-Y**

Order Code

Resistor-PPC-CAN-R

①

① Series and Type

CAN Terminating Resistor **Resistor-PPC-CAN-R**

PPC Complete Systems for analogue Hydraulic Testers PPC-04-plus / PPC-PAD-light

B



Complete System PPC-04-plus-SET (PPC-04-plus)



Complete System PPC-PAD-light-SET (PPC-PAD-light)

Product Description

The PPC complete systems are assembled in different versions according to customer requirements. All complete systems are supplied in a handy case with customised foam inserts and offer space for the components listed below:

Components

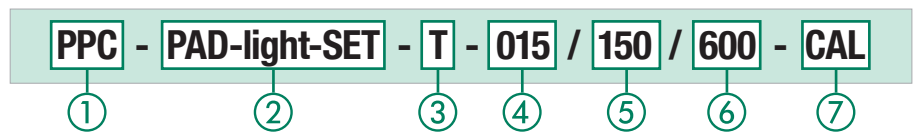
Standard Options for Complete Systems PPC-04-plus

- 1x Case-PPC-04-plus/PAD-light
- 1x Hydraulic Tester PPC-04-plus
- 1x Power supply incl. country-specific adaptor Power-Supply-PPC-PAD-light-MULTI
- Up to 3 Pressure Sensor-PPC-04/12-P with installed adaptors for STAUFF Test 20 (M16 x 2)
- 1x Temperature Sensor-PPC-04/12-T-M02 with installed SGV-16S-G-W3 (optional)
- Up to 2 connection cables (3 m / 9.84 ft)
- 3x Adaptors SAD for the STAUFF Test 15/12/10 series
- 1x USB cable 1m (USB A to Micro-USB)
- 1x Quick guide with link to: PC software and instructions

Standard Options for Complete Systems PPC-PAD-light

- 1x Case-PPC-04-plus/PAD-light
- 1x Hydraulic Tester PPC-PAD-light
- 1x Power supply incl. country-specific adaptor Power-Supply-PPC-PAD-light-MULTI
- Up to 3 Pressure Sensors with installed adaptors STAUFF Test 20 (M16 x 2)
- 1x Temperature Sensor-PPC-04/12-T-M02 with installed SGV-16S-G-W3 (optional)
- Up to 4 connection cables (3 m / 9.84 ft)
- 3x Adaptors SAD for the STAUFF Test 15/12/10 series
- 2x USB cable 1m (USB A to C and USB C to C)
- 1x Quick guide with link to: PC software and instructions

Order Codes



① Series and Type

Hydraulic Tester **PPC**

② Version

PPC-04-plus **04-plus-SET**
PPC-PAD-light **PAD-light-SET**

③ Temperature Sensor

without Temperature Sensor T and SGV **(none)**
with Temperature Sensor T and SGV **T**

④ Pressure Range and Pressure Sensor

1. Pressure Sensor **see table**

⑤ Pressure Range and Pressure Sensor

2. Pressure Sensor **see table**

⑥ Pressure Range and Pressure Sensor

3. Pressure Sensor **see table**

⑦ Calibration

without calibration certificate **(none)**
with calibration certificate (factory calibration) **CAL**

Pressure Range and Pressure Sensor

Pressure Range	Pressure Sensor		
000	When ordering a complete system with one or two pressure sensors, specify „000“ for the pressure range of the 2. and / or 3. pressure sensors.		
015	Pressure Range 1. Pressure Sensor	Pressure Range 2. Pressure Sensor	Pressure Range 3. Pressure Sensor
060			
150			
400			
600			
601			
z.B.	015 (15 bar)	060 (60 bar)	000 (0 bar)

Please keep in mind that two pressure sensors with identical measuring ranges are necessary for differential pressure measurements.

Alternative

If you need more space in the case for your components, STAUFF offers the **Case-PPC-PAD-plus** as an alternative. This can hold several measuring devices at the same time and offers a variety of storage options (at least 9 pressure sensors and 2 flow turbines and much more). The case is only available individually. The contents must be ordered separately.



PPC Complete Systems for CAN Hydraulic Testers PPC-04-CAN / PPC-PAD-light-CAN



Complete System PPC-PAD-light-CAN-SET (PPC-PAD-light-CAN)



Complete System PPC-04-plus-CAN-SET (PPC-04-plus-CAN)

B

Order Codes

PPC - PAD-light-CAN-X-SET - T - 160 / 400 / 600 - CAL

①

②

③

④

⑤

⑥

⑦

① Series and Type

 Hydraulic Tester **PPC**

② Version

 PPC-04-plus-CAN **04-plus-CAN-SET**

 PPC-PAD-light-CAN **PAD-light-CAN-SET**

 PPC-PAD-light-CAN-AUX **PAD-light-CAN-X-SET**

③ CAN Temperature Sensor

 without CAN Temperature Sensor T and SGV **(ohne)**

 with CAN Temperature Sensor T and SGV **T**

④ Pressure Range and Pressure Sensor

 1. CAN Pressure Sensor **see table**

⑤ Pressure Range and Pressure Sensor

 2. CAN Pressure Sensor **see table**

⑥ Pressure Range and Pressure Sensor

 3. CAN Pressure Sensor **see table**

⑦ Calibration

 without calibration certificate **(ohne)**

 with calibration certificate (factory calibration) **CAL**

Product Description

The PPC complete systems are assembled in different versions according to customer requirements. All complete systems are supplied in a handy case with customised foam inserts and offer space for the components listed below:

Components

Standard Options for Complete Systems PPC-04-plus-CAN

- 1x Case-PPC-04-plus/PAD-light
- 1x Hydraulic Tester PPC-04-plus-CAN
- 1x Power Supply incl. country-specific Adaptor
- Up to 3 CAN Pressure Sensor-PPC-CAN-P with installed Adaptors for STAUFF Test 20 (M16 x 2)
- CAN Temperature Sensor-PPC-CAN-T-M02 with installed SGV-16S-G-W3 (optional)
- Up to 3 CAN Connecting Cables
- Up to 2 CAN Y-Splitter Cables
- 1x CAN Terminating Resistor
- 3x Adaptors SAD for the STAUFF Test 15/12/10 series (standard for all PPC complete systems)
- 1x USB cable 1m (USB A to Micro-USB)
- 1x Quick guide with link to: PC software and instructions

Standard Options for Complete Systems
PPC-PAD-light-CAN or PPC-PAD-light-CAN-AUX

- 1x Case-PPC-04-plus/PAD-light
- 1x Hydraulic Tester PPC-PAD-light-CAN or PPC-PAD-light-CAN-AUX
- 1x Power Supply incl. country-specific Adaptor
- Up to 3 CAN Pressure Sensor-PPC-CAN-P with installed Adaptors for STAUFF Test 20 (M16 x 2)
- CAN Temperature Sensor-PPC-CAN-T-M02 with installed SGV-16S-G-W3 (optional)
- Up to 4 CAN Connecting Cables
- Up to 2 CAN Y-Splitter Cables
- 1x CAN Terminating Resistor
- 3x Adaptors SAD for the STAUFF Test 15/12/10 series (standard for all PPC complete systems)
- 1x USB cable 1m (USB A to C and USB C to C)
- 1x Quick guide with link to: PC software and instructions

Pressure Range and CAN Pressure Sensor

Pressure Range	CAN Pressure Sensor		
000	When ordering a complete system with one or two CAN pressure sensors, specify „000“ for the pressure range of the 2. and / or 3. CAN pressure sensors.		
016	Pressure Range 1. CAN Pressure Sensor	Pressure Range 2. CAN Pressure Sensor	Pressure Range 3. CAN Pressure Sensor
060			
160			
400			
600			
601			
z.B.	016 (16 bar)	060 (60 bar)	000 (0 bar)

Please keep in mind that two CAN pressure sensors with identical measuring ranges are necessary for differential pressure measurements.

Alternative

If you need more space in the case for your components, STAUFF offers the **Case-PPC-PAD-plus** as an alternative. This can hold several measuring devices at the same time and offers a variety of storage options (at least 9 pressure sensors and 2 flow turbines and much more). The case is only available individually. The contents must be ordered separately.



PPC Starter System - Type PPC-PAD-plus

B



Content of the case may vary



Trolley is optionally available (Trolley-Frame-Case-PPC-PAD-plus)

Product Description

An initial starter kit with hydraulic tester, different input modules, cables and accessories is also available in a case. This contains everything required for the preferred sensor connection variant. This means that cables for connecting 4 CAN bus sensors or 3/6 analogue sensors as well as the required input modules are included. Sensors and test couplings are not included and have to be ordered separately.

The case is robust, lightweight and contains two special foam inserts that protect the device and any accessories in a well structured storage solution.

The sets are available with a device with or without WIFI capability and can also be purchased as a calibrated version with certificate.

Individual Components

Delivery standard for complete system SET-PPC-PAD-plus

- PPC-PAD-plus
- 24 V DC/2.5 A power supply unit incl. country-specific adaptor
- USB 2.0 cable (2 m/6.56 ft)
- Quickguide with Link for PC-Software and Manual
- Case-PPC-PAD-plus

And the following equipment, depending on the set:

SET-PPC-PAD-plus-ANALOG-3

- 1 analogue input module
- 3 analogue cables, 3 m

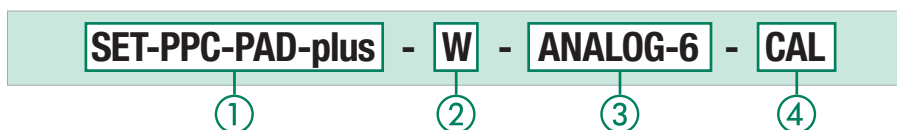
SET-PPC-PAD-plus-ANALOG-6

- 2 analogue input modules
- 6 analogue cables, 3 m

SET-PPC-PAD-plus-CAN-4

- 2 CAN cables, 0.5 m
- 2 CAN cables, 2 m
- 2 Y-splitters
- 2 terminating resistors

Order Codes



① Series and Type

Hydraulic Tester **SET-PPC-PAD-plus**

② WIFI

Without WIFI **(none)**
With WIFI **W**

③ Version

for 3 analogue STAUFF Sensors **ANALOG-3**
for 6 analogue STAUFF Sensors **ANALOG-6**
for 4 STAUFF CAN Sensors **CAN-4**

④ Calibration

Without calibration certificate **(none)**
With calibration certificate (factory calibration) **CAL**

Ordering table for measuring and test instruments

This list shows the individual components for the PPC-04-plus, PPC-06-plus, PPC-08-plus and PPC-PAD-plus Hydraulic Testers with their exact Order Codes.

* Pressure spikes up to 1000 bar/14500 psi

Description	Order Codes
1. Hydraulic Tester PPC-04-plus	
Hydraulic Tester PPC-04-plus with 2 sensor inputs, including accessories	PPC-04-plus
Hydraulic Tester PPC-04-plus with 2 sensor inputs, including accessories, calibrated	PPC-04-plus-CAL
CAN Hydraulic Tester PPC-04-plus-CAN with one CAN bus interface, including accessories	PPC-04-plus-CAN
Power Supply Unit (110/230 V AC) for PPC-04-plus with USB connection, including country-specific adaptor	Power-supply-PPC-04-plus-110/230V-USB
Case-PPC-04-plus/PAD-light (with foam insert)	Case-PPC-04-plus/PAD-light
2. Hydraulic Tester PPC-PAD-light	
Hydraulic Tester PPC-PAD-light for up to 4 sensor inputs, including accessories	PPC-PAD-light
Hydraulic Tester PPC-PAD-light for up to 4 sensor inputs, including accessories, calibrated	PPC-PAD-light-CAL
Hydraulic Tester PPC-PAD-light-CAN for up to 6 CAN interfaces, including accessories	PPC-PAD-light-CAN
Hydraulic Tester PPC-PAD-light-CAN-AUX for up to 6 CAN interfaces, Third-party Sensors, including accessories	PPC-PAD-light-CAN-AUX
Quick Charger	Power-Supply-PPC-PAD-light-MULTI
Case-PPC-04-plus/PAD-light (with foam insert)	Case-PPC-04-plus/PAD-light
3. Hydraulic Tester PPC-PAD-plus	
Hydraulic Tester PPC-PAD-plus for up to 48 STAUFF CAN interfaces, including accessories	PPC-PAD-plus
Hydraulic Tester PPC-PAD-plus for up to 48 STAUFF CAN interfaces, including accessories, calibrated	PPC-PAD-plus-CAL
Hydraulic Tester PPC-PAD-plus for up to 48 STAUFF CAN interfaces, including accessories, WIFI capability	PPC-PAD-plus-W
Hydraulic Tester PPC-PAD-plus für bis zu 48 STAUFF CAN interfaces, including accessories, WIFI capability, calibrated	PPC-PAD-plus-W-CAL
Analogue Input Module	INPUT-MODUL-ANALOG-PPC-PAD-plus
Analogue Input Module, calibrated	INPUT-MODUL-ANALOG-PPC-PAD-plus-CAL
Analogue Input Module, galvanically isolated sensor inputs	INPUT-MODUL-ANALOG-PPC-PAD-plus-GALV
Analogue Input Module, galvanically isolated sensor inputs, calibrated	INPUT-MODUL-ANALOG-PPC-PAD-plus-GALV-CAL
CAN Input Module	INPUT-MODUL-CAN-PPC-PAD-plus
Connector for third-party sensor inputs M12 5-pin	PLUG-PPC-PAD-plus-AUX-M12A/5
Carrying Strap	Carry-strap-PPC-PAD-plus
Power Supply Unit (110/230 V AC) for PPC-PAD-plus, including country-specific adaptor	Power-Supply-PPC-PAD-plus-MULTI
Case-PPC-PAD-plus (with foam insert)	Case-PPC-PAD-plus
Trolley	Trolley-Frame-Case-PPC-PAD-plus
4. Current/Voltage/Frequency Converter/Third-Party Sensors	
Current/Voltage/Frequency Converter/Third-Party Sensors (up to 4 A DC/48 V DC)	Sensorkonverter-PPC
5. Cables	
Analogue	
Connection Cable 3 m/9.84 ft (5-pin connection on both ends)	Cable-PPC-04/12-3
Extension Cable 5 m/16.40 ft (5-pin connection on both ends)	Cable-PPC-04/12-5-EXT
CAN	
CAN Connection Cable 0.5 m/1.64 ft	Cable-PPC-CAN0.5
CAN Connection Cable 2 m/6.65 ft	Cable-PPC-CAN2
CAN Connection Cable 5 m/16.40 ft	Cable-PPC-CAN5
CAN Connection Cable 10 m/32.81 ft	Cable-PPC-CAN10
CAN Y-Splitter Cable 0.3 m/0.98 ft	Cable-PPC-CAN-Y
CAN Terminating Resistor	Resistor-PPC-CAN

Ordering Table for Sensor System

All available individual components for the PPC Hydraulic Testers are listed here with their exact Order Codes.

* Pressure spikes up to 1000 bar/14500 psi

All pressure, temperature and flow rate sensors are available as calibrated versions.
Please add "-CAL" to the Order Codes.

Description	Order Codes
1. Pressure Sensors G1/4 (without adaptor)	
Analogue	
Pressure range from -1 ... 15 bar/-14.5 ... 217 psi relative pressure	Sensor-PPC-04/12-P-015
Pressure range from 0 ... 60 bar/0 ... 870 psi absolute pressure	Sensor-PPC-04/12-P-060
Pressure range from 0 ... 150 bar/0 ... 2175 psi absolute pressure	Sensor-PPC-04/12-P-150
Pressure range from 0 ... 400 bar/0 ... 5801 psi absolute pressure	Sensor-PPC-04/12-P-400
Pressure range from 0 ... 600 bar/0 ... 8702 psi absolute pressure	Sensor-PPC-04/12-P-600
Pressure range from 0 ... 600 bar/0 ... 8702 psi absolute pressure*	Sensor-PPC-04/12-P-601
CAN	
Pressure range from -1 ... 16 bar/-14.5 ... 232 psi relative pressure	Sensor-PPC-CAN-P-016
Pressure range from 0 ... 60 bar/0 ... 870 psi absolute pressure	Sensor-PPC-CAN-P-060
Pressure range from 0 ... 160 bar/0 ... 2321 psi absolute pressure	Sensor-PPC-CAN-P-160
Pressure range from 0 ... 400 bar/0 ... 5801 psi absolute pressure	Sensor-PPC-CAN-P-400
Pressure range from 0 ... 600 bar/0 ... 8702 psi absolute pressure	Sensor-PPC-CAN-P-600
Pressure range from 0 ... 600 bar/0 ... 8702 psi absolute pressure*	Sensor-PPC-CAN-P-601
2. Pressure/Temperature Sensors G1/2 (without adaptor)	
Analogue	
Pressure range from -1 ... 15 bar/-14.5 ... 217 psi relative pressure	Sensor-PPC-04/12-PT-015
Pressure range from 0 ... 60 bar/0 ... 870 psi absolute pressure	Sensor-PPC-04/12-PT-060
Pressure range from 0 ... 150 bar/0 ... 2175 psi absolute pressure	Sensor-PPC-04/12-PT-150
Pressure range from 0 ... 400 bar/0 ... 5801 psi absolute pressure	Sensor-PPC-04/12-PT-400
Pressure range from 0 ... 600 bar/0 ... 8702 psi absolute pressure	Sensor-PPC-04/12-PT-600
Pressure range from 0 ... 600 bar/0 ... 8702 psi absolute pressure*	Sensor-PPC-04/12-PT-601
CAN	
Pressure range from -1 ... 16 bar/-14.5 ... 232 psi relative pressure	Sensor-PPC-CAN-PT-016
Pressure range from 0 ... 60 bar/0 ... 870 psi absolute pressure	Sensor-PPC-CAN-PT-060
Pressure range from 0 ... 160 bar/0 ... 2321 psi absolute pressure	Sensor-PPC-CAN-PT-160
Pressure range from 0 ... 400 bar/0 ... 5801 psi absolute pressure	Sensor-PPC-CAN-PT-400
Pressure range from 0 ... 600 bar/0 ... 8702 psi absolute pressure	Sensor-PPC-CAN-PT-600
Pressure range from 0 ... 600 bar/0 ... 8702 psi absolute pressure*	Sensor-PPC-CAN-PT-601
3. Process Connection Adaptors for PPC Pressure Sensors	
Adaptor G1/4 to M16 x 2 (STAUFF Test 20)	SDA-20-G1/4-W3
Adaptor G1/2 to M16 x 2 (STAUFF Test 20)	SDA-20-G1/2-W3
Adaptor M16 X 2 to M16 x 1.5 (STAUFF Test 20 to STAUFF Test 15)	SAD-20/15-B-W3
Adaptor M16 X 2 to S12.65 x 1.5 (STAUFF Test 20 STAUFF Test 12)	SAD-20/12-B-W3
Adaptor M16 X 2 to plug-in system (STAUFF Test 20 to STAUFF Test 10)	SAD-20/10-B-W3
4. Temperature measurement (temperature sensors -40°C ... +150 °C/-40 °F ... +302 °F)	
Analogue	
Screw-In Temperature Sensor for line installation (M10 x 1)	Sensor-PPC-04/12-T-M02
Screw-In Temperature Sensor for line installation (G1/4)	Sensor-PPC-04/12-T-B02
Rod-type Temperature Sensor for tank/reservoir measurements	Sensor-PPC-04/12-TSH
Straight Fitting with M10 x 1 connection (for PPC-04/12-T-M02)	SGV-16S-G-W3
CAN	
Screw-In Temperature Sensor for line installation (M10 x 1)	Sensor-PPC-CAN-T-M02
Screw-In Temperature Sensor for line installation (G1/4)	Sensor-PPC-CAN-T-B02
Straight Fitting with M10 x 1 connection (for PPC-CAN-T-M02)	SGV-16S-G-W3
5. Flow Rate Measurement (Turbine Flow Meter SFM with integrated signal converter)	
Analogue	
Measuring range from 1 ... 15 l/min / 0.3 ... 3.9 US GPM	Flow-meter-PPC-04/12-SFM-015
Measuring range from 4 ... 60 l/min / 1 ... 15.9 US GPM	Flow-meter-PPC-04/12-SFM-060
Measuring range from 6 ... 150 l/min / 1.6 ... 39.6 US GPM	Flow-meter-PPC-04/12-SFM-150
Measuring range from 10 ... 300 l/min / 2.7 ... 79 US GPM	Flow-meter-PPC-04/12-SFM-300
Measuring range from 20 ... 600 l/min / 5.3 ... 158 US GPM	Flow-meter-PPC-04/12-SFM-600
CAN	
Measuring range from 1 ... 15 l/min / 0.3 ... 3.9 US GPM	Flow-meter-PPC-CAN-SFM-015
Measuring range from 4 ... 60 l/min / 1 ... 15.9 US GPM	Flow-meter-PPC-CAN-SFM-060
Measuring range from 6 ... 150 l/min / 1.6 ... 39.6 US GPM	Flow-meter-PPC-CAN-SFM-150
Measuring range from 10 ... 300 l/min / 2.7 ... 79 US GPM	Flow-meter-PPC-CAN-SFM-300
Measuring range from 20 ... 600 l/min / 5.3 ... 158 US GPM	Flow-meter-PPC-CAN-SFM-600
6. Rotational speed measurement	
Analogue	
Speed Sensor with integrated Connection Cable 2 m/6.56 ft	Sensor-PPC-04/12-SDS-CAB
Contact Adaptor	Adaptor-PPC-04/12-SKA-contact
Focusing Adaptor	Adaptor-PPC-04/12-SFA-focus

Wireless Pressure Measurement System PT-RF

B



The PT-RF series of pressure transmitters are an alternative solution for universal pressure measurements for fluid technology applications, which will provide benefits for system operators, maintenance personnel and repair technicians as well as for original equipment manufacturers.

The advantages resulting from the use of the new technology for system operators, maintenance personnel and repair technicians are clear:

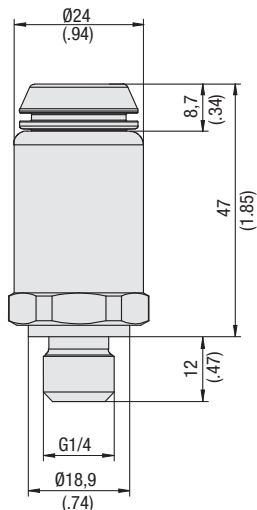
Measurements can be carried very easily, without extensive training and within a few seconds at the press of a button and then documented in a reliable process.

Unscrewing and re-installing pressure gauges or other measuring and display devices – practically a temporary opening of the system – is not required. Potential hazards for people, machines and the environment, for example from emitted waste oil in the test hose or leaks at the measuring point, as well as ingress of dirt into the system (e.g. in dusty environments) can be effectively excluded.

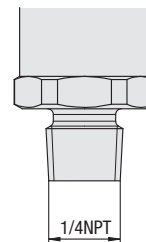
Original equipment manufacturers will also benefit from this new technology: If the pressure transmitters are installed at their factory already, the innovative technology can provide a competitive edge over alternative suppliers and open up specific advantages for the users, increasing the value retention of their own devices in the long term.

If the pressure transmitters are installed directly in the system or pipeline for permanent use, they protrude only slightly more than conventional hydraulic test couplings and meet the highest demands with regard to space requirements and weight.

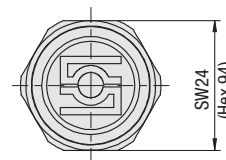
Pressure Transmitter - Type PT-RF



Process connection G1/4 (B04)



Process connection 1/4NPT (N04)



B

Product Description

The pressure transmitters from the PT-RF series are integrated into fluid technology plants and systems permanently or temporarily using the appropriate process connection adapters. The energy required for a measurement is transferred to the pressure transmitter via the antenna of the reading device using wireless RFID technology. This means that the pressure transmitters require neither internal nor external power supply and are completely maintenance-free.

Technical Data

Wetted Parts

- Suitable for liquid and gaseous media

Materials

- Housing: Stainless Steel 1.4305
- Sealing (B04): FKM (Viton®)
- Cap: Polyamide (glass fibre-reinforced)

Dimensions / Weight

- Dimensions: 59 x 26 mm / 2.32 x 1.02 in
- Weight: 80 g / .18 lbs

Temperature Range

- Media temp. (N04): -40°C ... +135°C / -40°F ... +275°F
- Media temp. (B04): -30°C ... +135°C / -22°F ... +275°F
- Ambient temp.: -40°C ... +85°C / -40°F ... +185°F
- Storage temp.: -55°C ... +125°C / -67°F ... +257°F

Electrical Data

- Sampling rate: typ. 250 ms / max. 400 ms
- Long-term stability: according to IEC EN 60770-1
max. ± 0,25 % FS* / a
- Load cycles (10⁶): 10
- Vibration loading: acc. to IEC 60068-2-6 (20 g)
- Shock loading: acc. to IEC 60068-2-27 (30 g) 11ms

Protection Rating

- IP69 protection rating: Dust tight and protected against high-pressure and steam cleaning

Order Codes

PT	-	RF	-	B00600	-	B04
①		②		③		④
① Series and Type Pressure Transmitter				③ Pressure Range see table		
② Version Signal transmission via RFID technology				④ Process Connection		
				G1/4		B04
				1/4 NPT		N04

Pressure Range and Accuracies

Version	Pressure Range and Accuracies					
Pressure Transmitter PT-RF	Pressure Range (bar/PSI)	Type of Measurement	Maximum Pressure (bar/PSI)	Burst Pressure (bar/PSI)	Accuracy (±% FS*) typ.	Accuracy (±% FS*) max.
B00016	0 ... 16	Relative pressure	32	48	0,25	0,5
	0 ... 232		464	696		
B00060	0 ... 60	Relative pressure	120	180	0,25	0,5
	0 ... 870		1740	2610		
B00160	0 ... 160	Relative pressure	320	480	0,25	0,5
	0 ... 2320		4641	6961		
B00400	0 ... 400	Relative pressure	800	1200	0,25	0,5
	0 ... 5801		11603	17405		
B00600	0 ... 600	Relative pressure	1200	1800	0,25	0,5
	0 ... 8702		17404	26107		

Temperature behaviour: max. ± 0,2 % FS* /10K (test condition 25 °C; 45 % r. H.)

* FS = Full Scale

Process Connection Adaptors for Pressure Transmitter PT-RF

Various adaptors are available in addition to the pressure transmitters from the PT-RF series, allowing connection to the known STAUFF Test 20 system as well as installation in pipes.



SDA-20-G1/4-W3

Adaptor for process connection G1/4 (B04) on test coupling STAUFF Test 20 (connection thread M16 x 2)



SRS-G1/4-*-V-G-W3**

Straight fitting with adaptor
Note: Please replace *** with tube-Ø and series (L or S).



SMD-20-1/4NPT-W3

Adaptor for process connection 1/4NPT (N04) on test coupling STAUFF Test 20 (connection thread M16 x 2)

Dimensional drawing: All dimensions in mm (in).

Reader ■ Type Reader-PT-RF



B

Order Code

Reader-PT-RF

①

① Series and Type

 Reader **Reader-PT-RF**

Standard option:

- Reader-PT-RF
- Quickguide
- USB 2.0 cable (1 m / 3.28 ft)
- 5 V DC / 1 A power supply incl. country-specific adaptors

Technical Data

Material

- Housing made of ABS

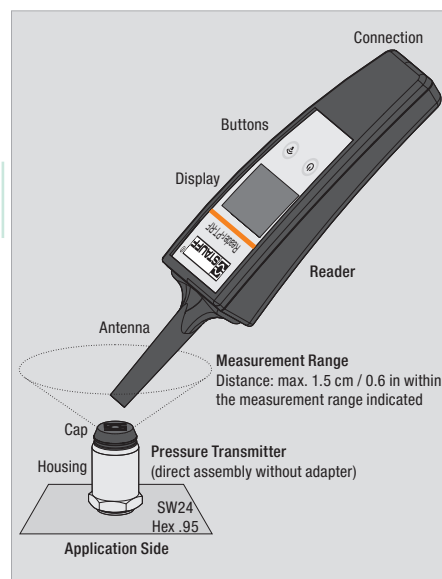
Dimensions / Weight

- Dimensions: 76 x 35 x 240 mm / 3.0 x 1.38 x 9.45 in
- Weight: 220 g / .49 lbs

Measurements / Display

- Pressure: in bar and PSI
- Temperature: in °C and °F
- Display: graphic, LED backlight
- Visible area: 55 x 46 mm / 2.17 x 1.81 in
- Resolution: 128 x 64 Pixel

Set Up



Power Supply

- Battery: Lithium Ion (3,7 V DC / 900 mAh)
- Operating time approx. 6h (approx. 1800 individual measurement)

Temperature Range

- Ambient temp.: -20 °C ... +70 °C / -4 °F ... +158 °F
- Storage temp.: -25 °C ... +60 °C / -13 °F ... +140 °F
- Storage temperature: -20...+85 °C
- Rel. humidity: < 80 %
- CE certified

Product Description

The hand-held readers transfer the energy required for a measurement to the pressure transmitter using RFID technology. All that is required is a maximum distance of 1.5 cm / 0.6 in from the antenna to the tip of the pressure transmitter for the duration of the measurement.

When the pressure transmitter is activated by the press of a button, a current measured value is determined within only 0.5 seconds and then immediately transmitted back to the reading device together with other relevant information and then output on the illuminated display and stored. Over 15,000 of these measurement sets can be stored in the internal memory of the device.

PC Software

The software included with the delivery allows transmission of the stored measured values from the reading device to the PC, subsequent evaluation and export, e.g. to Microsoft Excel®.

Electrical Data / Interface

- Sampling rate: typ. 250 ms / max. 400 ms
- Interface: Micro USB
- EMV: EN 61326-1:2013
EN 300330

Protection Rating

- IP65 protection rating: Dust tight and protected against water jets

Type of Measurement

Start Measurement

1. Switch on the reader using the function button.

During the brief start process, the charge state of the lithium ion battery (Battery) is shown on the display and the share of the currently occupied data memory (MemUsed) in percent as well as the current date and time.

2. Position the tip of the antenna of the reader inside the measurement range of the pressure transmitter and hold this position as long as possible during the entire measurement process.

Individual Measurement (Single Value)

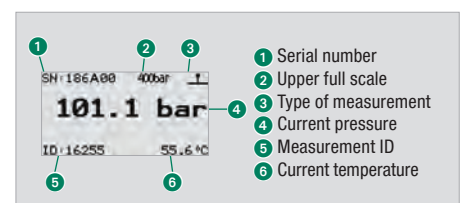
3. Start the individual measurement by tapping the function button once.

Permanent Measurement (Multiple Values)

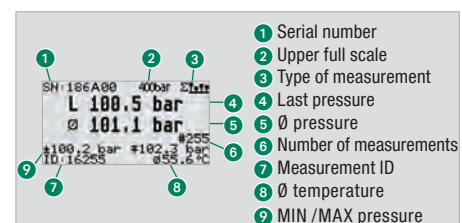
3. Start the permanent measurement by holding down the function button.

The simplest way of recognising the successful start of a permanent measurement is the change in the corresponding symbol in the upper right-hand corner of the display. The absolute number of the values determined as part of the measurement process is shown below the current pressure.

4. End a continuous measurement by releasing the function key.



Display after successful individual measurement



Display after successful permanent measurement

Complete system ▪ Type PT-RF-SET



Complete system in case PT-RF-SET

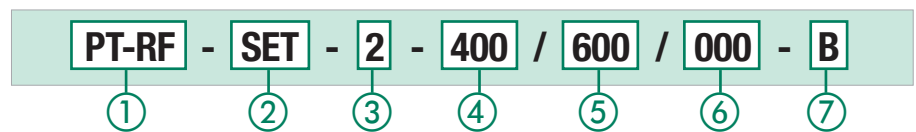
Product Description

The PT-RF-SET complete system is compiled in different versions according to customer requirements. All complete systems are supplied in a handy carrying case containing individually shaped foam inserts for a maximum of 10 pressure transmitters and 10 process connection adaptors and offering space for the following components:

Standard Option

- 1x Reader-PT-RF
- up to 3 Pressure Transmitters PT-RF
- up to 3 Process Connection Adaptors SDA or SMD
- 1x Quickguide
- 1x USB 2.0 cable(1 m / 3.28 ft)
- 1x Power Supply incl. country-specific adaptors

Order Codes



① Series and Type Series PT-RF	PT-RF	④ Pressure Range / Version 1 st pressure transmitter	see table
② Version Complete system in case	SET	⑤ Pressure Range / Version 2 nd Pressure Transmitter	see table
③ Number of Pressure Transmitters in the Set 1x pressure transmitter 2x pressure transmitter 3x pressure transmitter	1 2 3	⑥ Pressure Range / Version 3 rd Pressure Transmitter	see table
		⑦ Process Connection Adaptor Adaptor SDA for process connection G1/4 (B04) Adaptor SMD for process connection 1/4NPT (N04)	B N

Pressure Transmitter: Pressure Range and Version

Pressure Range	Version of Pressure Transmitter
000	When ordering a complete system with one or two pressure transmitters, the pressure range for the 2 nd and 3 rd pressure transmitter is given as "000".
016	Version pressure transmitter: B00016 (pressure range: 0 ... 16 bar / 0 ... 232 PSI)
060	Version pressure transmitter: B00060 (pressure range: 0 ... 60 bar / 0 ... 870 PSI)
160	Version pressure transmitter: B00160 (pressure range: 0 ... 160 bar / 0 ... 2320 PSI)
400	Version pressure transmitter: B00400 (pressure range: 0 ... 400 bar / 0 ... 5801 PSI)
600	Version pressure transmitter: B00600 (pressure range: 0 ... 600 bar / 0 ... 8702 PSI)
e.g.	400 (400 bar) 600 (600 bar) 000 (0 bar)

Spare Parts / Accessories



Case-Reader-PT-RF

Product Description

In addition to the Charger-Set-Reader-PT-RF which is available as a spare part, the Case-PT-RF-Set is also available as an individual item for assembling a complete system later on.

The Case-Reader-PT-RF is available if only a storage case for the reading device is required. It only provides space for the reading device and the associated accessories (without pressure transmitters and process connection adaptors).

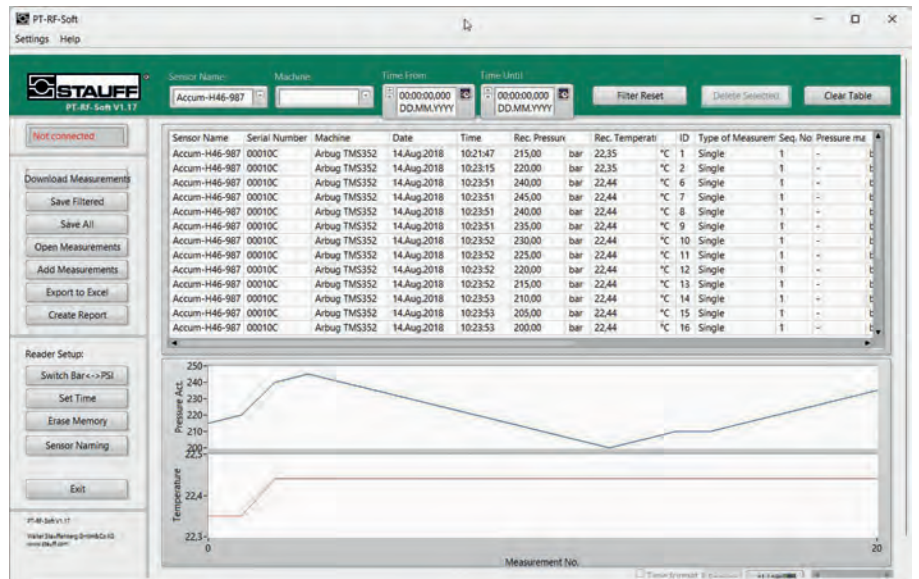
Order Codes



① Spare Parts / Accessories	
Case, small	Case-Reader-PT-RF
Case, large	Case-PT-RF-SET
5 V DC / 1 A power supply incl. country-specific adaptors and USB 2.0 cable	Power-Supply-PT-RF- Reader-MULTI
Adaptor for pressure transmitter (B04)	SDA-20-G1/4-W3
Adaptor for pressure transmitter (N04)	SMD-20-1/4NPT-W3
Straight fitting with adaptor	SRS-G1/4-***-V-G-W3

Software PT-RF-Soft

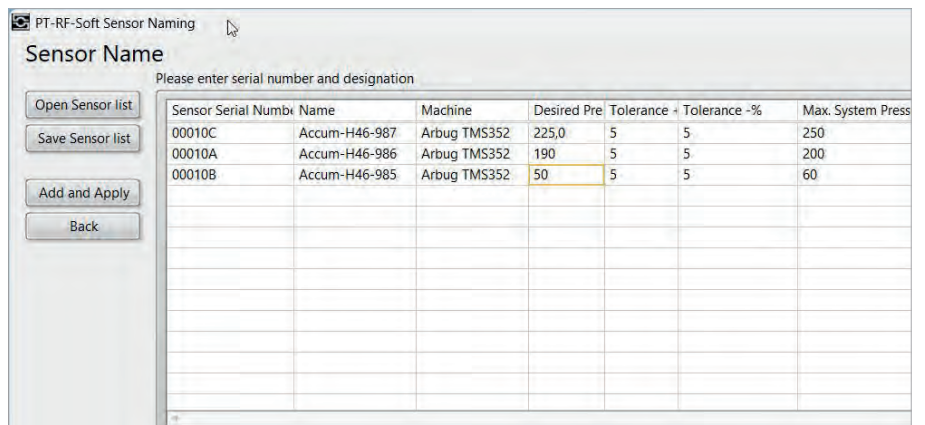
Option for complete documentation of test results, display of pressure curves, export of measurement data via CSV file and creation of customer-specific measurement reports.



Evaluation of the measured values recorded by the reader and direct comparison with previous measurement data.



Customer-specific reports can be created quickly and easily from the measurement data.



Serial numbers of the sensors can be clearly assigned to a measuring point or machine. New measurement data is assigned the correct name immediately after downloading.

Application of the Wireless Pressure Measurement System PT-RF



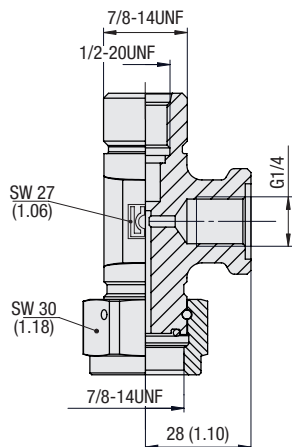
Adaptor Type SBAA-P-FV



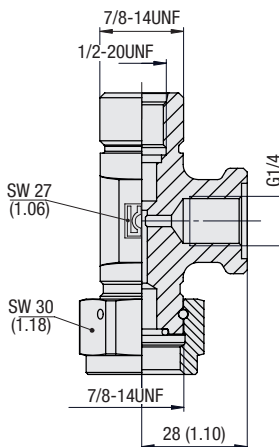
Adaptor Type SBAA-FV

Accumulator Adaptor - Type SBAA / SDAA

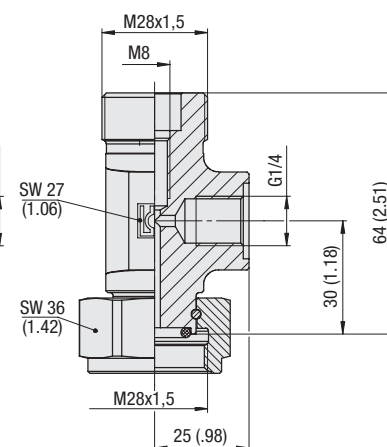
B



Bladder accumulator adaptor SBAA-CV



Bladder accumulator adaptor SBAA-FV



Diaphragm accumulator adaptor SDAA

Product Description

Membrane and bladder accumulators are important components of modern hydraulic systems. Monitoring the nitrogen pressure level is becoming ever more important for ensuring correct operation.

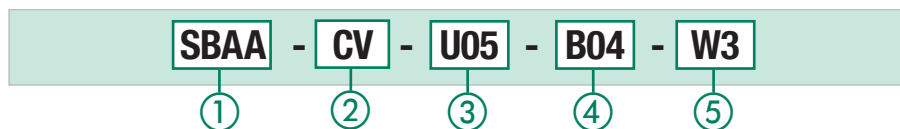
The STAUFF Accumulator Adaptor together with the PT-RF pressure sensors allow maintenance personal to quickly and easily check the accumulator pressure without pressure loss. Pressure values, serial numbers, date and time will automatically be stored in the memory of the reader and then easily and conveniently read out on the PC later on.

For this, the Accumulator Adaptor is screwed onto the nitrogen connection of the accumulator and a PT-RF pressure sensor is attached at the side.

Technical Data

- max. Pressure: 400 bar / 5801 PSI
- Burst Pressure: 1600 bar / 23206 PSI
- Sealing Material: NBR (Buna-N®)

Order Codes



1 Series and Type

STAUFF Bladder Accumulator Adaptor	SBAA
7/8-14UNF Connection Thread	
STAUFF Diaphragm Accumulator Adaptor	SDAA
M28x1.5 Connection Thread	

2 Adaptor Type (only for SBAA)

for accumulators with changeable valve (only for SBAA)	CV
for accumulators with fixed valve (only for SBAA)	FV

3 Valve Connection Thread

1/2-20UNF (only for SBAA)	U05
M8 (only for SDAA)	M08

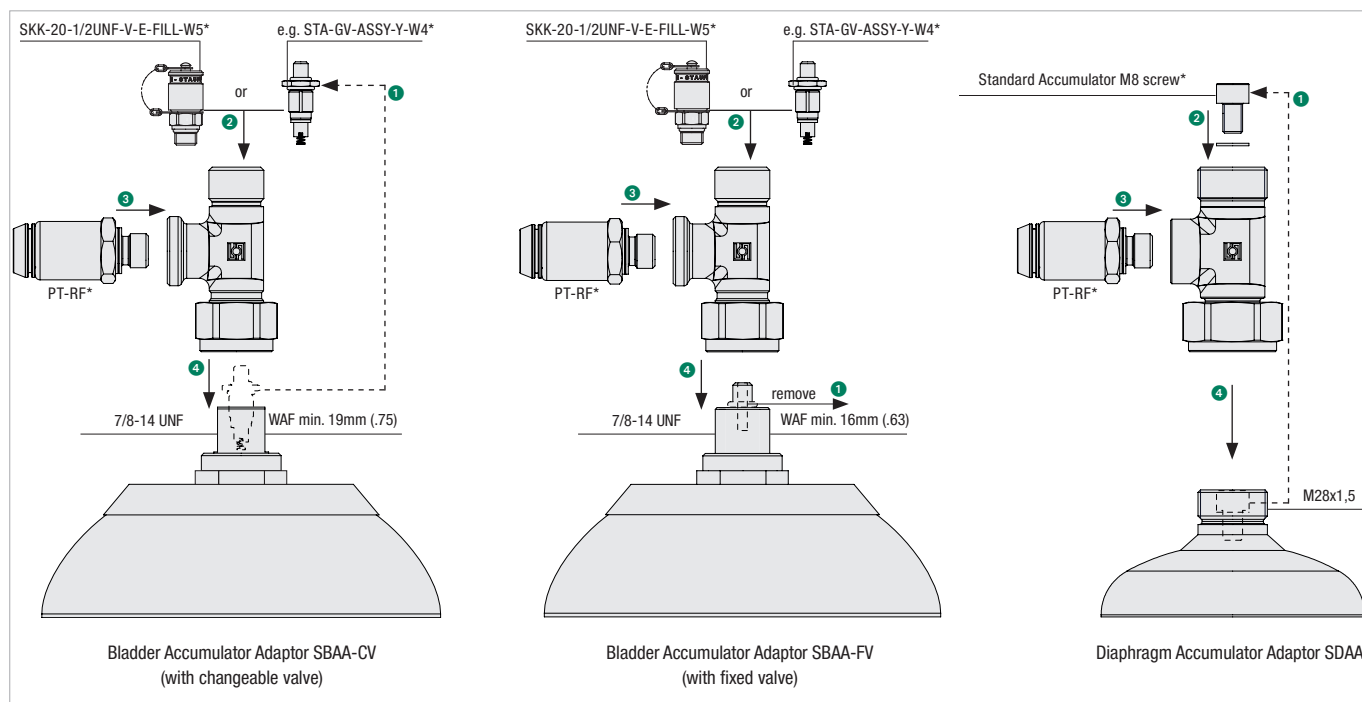
4 Sensor Connection Thread

G1/4 Connection Thread	B04
------------------------	------------

5 Material Code

Steel, zinc/nickel-plated	W3
---------------------------	-----------

Set Up

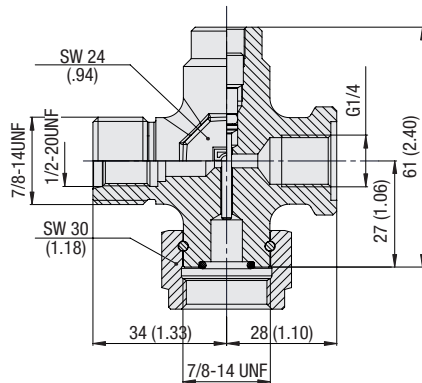


*not included.

Dimensional drawing: All dimensions in mm (in).

Accumulator Adaptor - Type SBAA-P

connection without draining the nitrogen accumulator



B

Order Codes

SBAA-P - FV - U05 - B04 - W3

①

②

③

④

⑤

① Series and Type

 STAUFF Bladder Accumulator Adaptor
Nachrüstung ohne Speicherentleerung

SBAA-P

② Adaptor Type

for accumulators with fixed valve

FV

③ Valve Connection Thread

1/2-20UNF

U05

④ Sensor Connection Thread

G1/4 Anschlussgewinde

B04

⑤ Material Code

Steel, zinc/nickel-plated

W3

Product Description

- nitrogen pressure on hydraulic accumulators quickly and easily
- Contactless digital measurement, recording and documentation, no screwing, no connecting
- Maintenance-free, no battery and handy, lightweight reader
- Easy retrofitting, without pressure loss and without great effort

Membrane and bladder accumulators are important components of modern hydraulic systems. Monitoring the nitrogen pressure level is becoming ever more important for ensuring correct operation.

The STAUFF Accumulator Adaptor together with the PT-RF pressure sensors allow maintenance personal to quickly and easily check the accumulator pressure without pressure loss. Pressure values, serial numbers, date and time will automatically be stored in the memory of the reader and then easily and conveniently read out on the PC later on.

For this, the Accumulator Adaptor is screwed onto the nitrogene connection of the accumulator and a PT-RF pressure sensor is attached at the side.

The SBAA-P adaptor for hydraulic bladder accumulators represents a consistent further development in accumulator adaptation.

It enables monitoring of the nitrogen filling without having to empty the accumulator during installation, as is necessary with the simple SBAA.

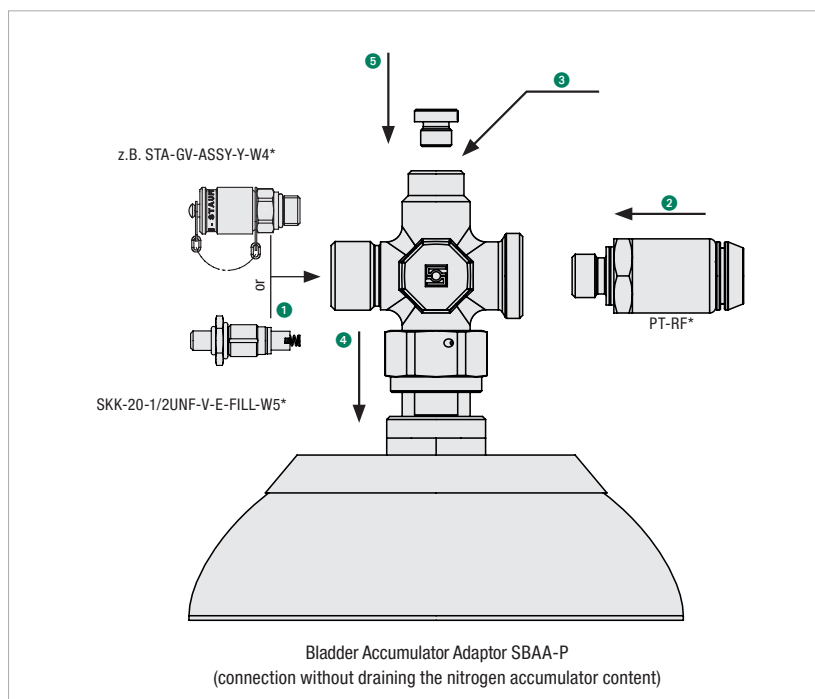
The SBAA-P is screwed directly onto the existing accumulator valve with sensor* and additional valve*. The valve opening tappet opens the accumulator valve of the hydraulic accumulator by means of an Allen key.

A blanking plug serves to additionally seal and secure the adaptor. Retrofitting with this accumulator adaptor is possible within a few minutes without emptying the accumulator and the accumulator pressure can be read out immediately using the PT-RF sensor.

Technical Data

- max. Pressure: 400 bar / 5801 PSI
- Burst Pressure: 1600 bar / 23206 PSI
- Sealing Material: NBR (Buna-N®)

Set Up



*not included.

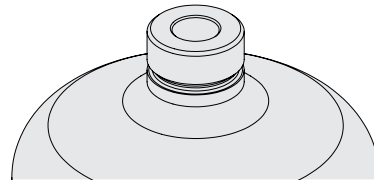
Dimensional drawing: All dimensions in mm (in).

*not included.

SDAA

The SDAA is designed for use with diaphragm accumulators.

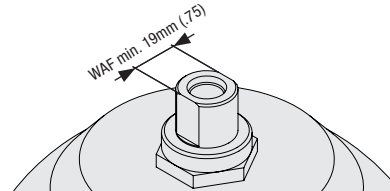
To use the adaptor, the M8 screw in the accumulator has to be removed with the sealing ring and re-inserted into the upper connection of the adaptor. The adaptor is supplied with a replacement seal (BD-Ring-U02-W32-B), so worn or defective seals can be replaced. The conventional filling set is used for refilling.



SBAA-CV

The SBAA-CV is designed for use with bladder accumulators with changeable valves. The spanner area (WAF) on the accumulator connection **cannot be smaller than 19 mm / .75 in.**

To use the adaptor, the original valve must be unscrewed from the accumulator connection, and – if it fits (external thread 1/2-20UNF) – inserted into the upper connection of the adaptor again. The conventional filling set is used for refilling. If the original valve does not have a matching thread, either a default gas valve (e.g. STA-GV-ASSY-Y-W4) or a test connection SKK-FILL (SKK-20-1/2UNF-V-E-FILL-W5) can be used, which are offered by STAUFF as accessories.

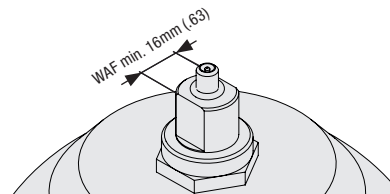


!The Spanner area on the accumulator connector cannot be smaller than 19mm / .75in!

SBAA-FV and SBAA-P-FV

The SBAA-FV is designed for use with bladder accumulators with a fixed valve head (7.5 mm / 0.29 in). The spanner width (WAF) on the accumulator connection **cannot be smaller than 16 mm / .63 in.**

For use the SBAA-FV, the valve insert must be removed from the valve head to allow filling through the adaptor. A new valve with an external thread 1/2-20UNF must then be inserted into the upper connection of the adaptor. STAUFF offers a matching default gas valve (e.g. STA-GV-ASSY-U-W3) or a test connection SKK-FILL (SKK-20-1/2UNF-V-E-FILL-W5). With the SBAA-P-FV the original valve does not have to be removed and remains in the accumulator.



!The Spanner area on the accumulator connector cannot be smaller than 16mm / .63in!

Accessories / Spare Parts

Order Codes

Accessories / Spare Parts

①

① Accessories / Spare Parts

Sealing for SDAA	BD-Ring-U02-W32-B
Gas Valve (Type 8V1 - ISO 4570)	STA-GV-ASSY-Y-W4
Test connection SKK	SKK-20-1/2UNF-V-E-FILL-W5

Application



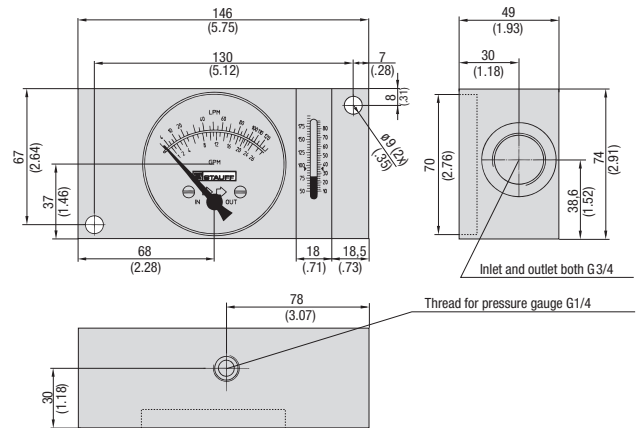
Adaptor Type SBAA-CV and SBAA-FV



Adaptor Type SBAA-P-FV

Flow Indicator ■ Types SDM / SDMKR

B



Product Description

Analogue flow indicators for measuring the flow rate of fluids in mobile and industrial hydraulics.

The SDMKR is designed with a loading valve for the strain test of the hydraulic system to facilitate precise control of the operating pressure. In addition, this product can also be subjected to a reverse flow direction (without flow rate determination).

Features

- Suitable for Mineral Oil (Aluminium), HFC Fluids and Water (Brass)
- Designed for in-line installation
- Mechanical flow measurement
- Controlling working pressure with a pressure control valve (only SDMKR)
- Flow indication in l/min and GPM for Aluminium units, Brass units have flow indication for Water and Oil both in l/min
- Aluminium unit: Dual scale
- Brass unit: Single scale
- Thread to connect with pressure gauge (only SDM)

Technical Data

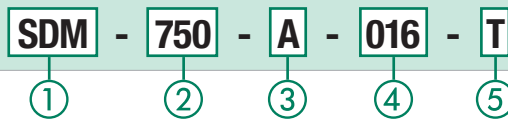
Accuracy

(at a kinematic viscosity of 28cSt):

- Flow: ±4 % FSD
- Temperature: ±2,5 °C / ±5 °F
- Pressure (only SDMKR): ±1.6 % FS*
- Temp. measuring range: +20 °C ... +110 °C / +55 °F ... +245 °F
- Media temperature permanent: +80 °C / +176 °F
- temporary (<10 min.): +110 °C / +245 °F

Note: Other thread versions available on request.

Order Codes



① Series and Type

Flow Indicator Type SDM	SDM
Flow Indicator Type SDMKR	SDMKR

② Size

750	750
1500 (only SDM)	1500

③ Housing Material

Aluminium	A
Brass (only SDM)	B

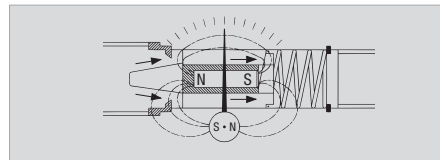
④ Flow Ranges

See table on page 63

⑤ Thermometer

With integrated thermometer (standard option) **T**

Functional Principal Flow Measuring



The flow indicators SDM and SDMKR have a sharp-edged orifice and a tapered metering piston, which moves in proportion to changes of flow against a spring. In no flow condition the piston closes the opening and the pointer indicates zero.

With increasing flow and differential pressure the piston moves against the calibrated spring. The piston movement is directly proportional to the flow rate and is magnetically coupled to the rotary pointer. During this function the sharp-edged orifice minimises the effects of viscosity. The flow is shown on a calibrated scale in l/min and gal/min.

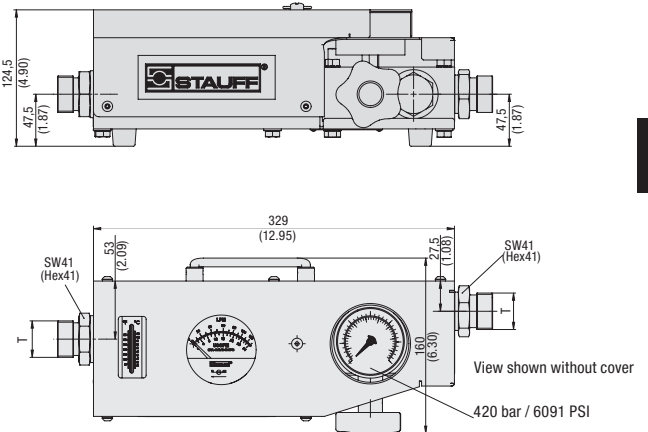
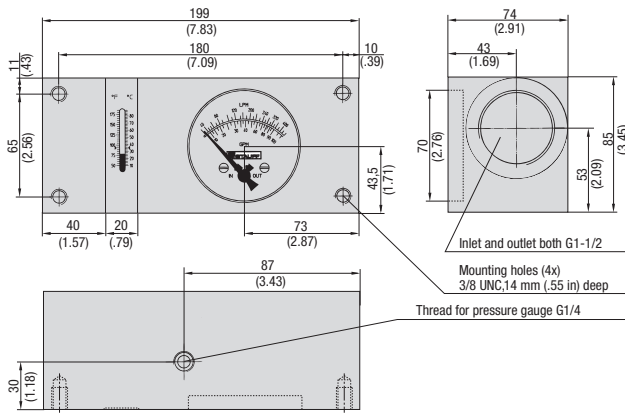
Controlling Working Pressure with SDMKR

The pressure control valve of the SDMKR is directly connected to a flow-block and together with the integrated pressure gauge it allows an exact control of the working pressure in the maximum range.

For protection the SDMKR has two rupture disks. At a pressure >420 bar the disks burst and the fluid is by-passed around the valve. The rupture disks (other pressure ranges on request) can be replaced easily.

The SDMKR also permits flow in the reverse direction (without flow rate determination).

Flow Indicators - Types SDM / SDMKR

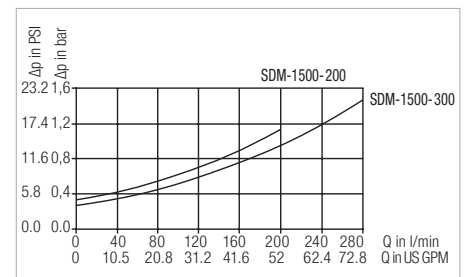
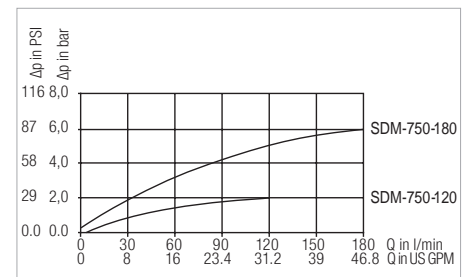
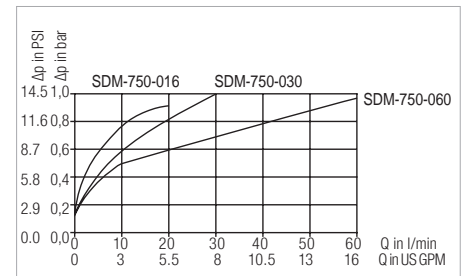


Technical Data

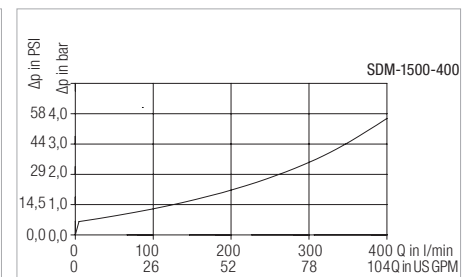
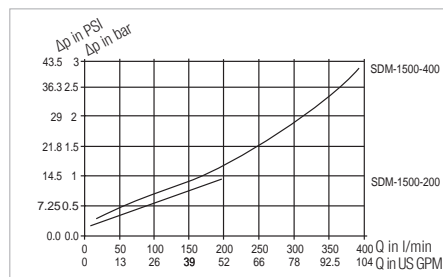
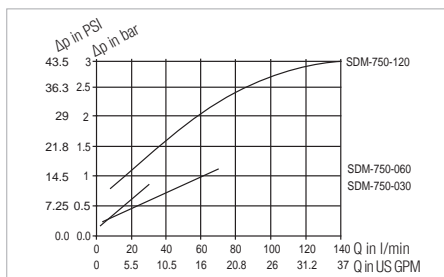
Max. Working Pressure (bar/PSI)	Flow Range (l/min/US GPM) Aluminum Units	Flow Range Brass Units (only SDM) *	Weight (kg/lbs)	Connection T	Order Codes
420	2 - 16	-	1,36	G3/4	SDM-750-A-016-T
6091	0.5 - 4	-	3.0	G3/4	SDM-750-A-030-T
420	2 - 30	-	1,36	G3/4	SDM-750-A-030-T
6091	0.5 - 8	-	3.0	G3/4	SDM-750-A-060-T
420	2 - 60	-	1,36	G3/4	SDM-750-A-060-T
6091	0.5 - 16	-	3.0	G3/4	SDM-750-A-120-T
420	4 - 120	-	1,36	G3/4	SDM-750-A-120-T
6091	1 - 32	-	3.0	G3/4	SDM-750-A-180-T
420	10 - 180	-	1,36	G3/4	SDM-750-A-180-T
6091	4 - 48	-	3.0	G3/4	SDM-750-B-030-T
420	-	2 - 30 l/min in oil	3,80	G3/4	SDM-750-B-030-T
6091	-	2 - 30 l/min in water	8,40	G3/4	SDM-750-B-030-T
420	-	3 - 60 l/min in oil	3,80	G3/4	SDM-750-B-060-T
6091	-	3 - 70 l/min in water	8,40	G3/4	SDM-750-B-060-T
420	-	4 - 120 l/min in oil	3,80	G3/4	SDM-750-B-120-T
6091	-	4 - 140 l/min in water	8,40	G3/4	SDM-750-B-120-T
350	10 - 200	-	3,0	G1-1/2	SDM-1500-A-200-T
5075	5 - 50	-	6,61	G1-1/2	SDM-1500-A-200-T
350	20 - 300	-	3,0	G1-1/2	SDM-1500-A-300-T
5075	4 - 80	-	6,61	G1-1/2	SDM-1500-A-300-T
350	20 - 400	-	3,0	G1-1/2	SDM-1500-A-400-T
5075	5 - 100	-	6,61	G1-1/2	SDM-1500-A-400-T
350	-	10 - 200 l/min in oil	8,0	G1-1/2	SDM-1500-B-200-T
5075	-	10 - 200 l/min in water	17,64	G1-1/2	SDM-1500-B-200-T
350	-	20 - 400 l/min in oil	8,0	G1-1/2	SDM-1500-B-400-T
5075	-	20 - 400 l/min in water	17,64	G1-1/2	SDM-1500-B-400-T
420	2 - 30	-	6,6	G3/4	SDMKR-750-A-030-T
6091	0.5 - 8	-	14,55	G3/4	SDMKR-750-A-030-T
420	5 - 60	-	6,6	G3/4	SDMKR-750-A-060-T
6091	1.3 - 16	-	14,55	G3/4	SDMKR-750-A-060-T
420	5 - 120	-	6,6	G1	SDMKR-750-A-120-T
6091	1.3 - 32	-	14,55	G1	SDMKR-750-A-120-T
420	10 - 200	-	6,6	G1	SDMKR-750-A-200-T
6091	4 - 53	-	14,55	G1	SDMKR-750-A-200-T

Flow Curves - Aluminium Version (Oil)

(Curves refer to kinematic viscosity of 25cSt):



Flow Curves - Brass Version (Water)



* The Brass units have a scale for water and oil – l/min.
Dimensional drawings: All dimensions in mm (in).

Introduction 66

Testing standards and oil purity 67

Overview of particle counters 68

Particle counting in general 69

PC-Software 69

STAUFF Contamination Analyze 69

Particle Counters 70 - 77



Professional 70

LasPaC-3-P



Mobile 74

LasPaC-II-M



Bottle Sampler Unit 76

Bottle-Sampler-LasPaC

Moisture/ Temperature Sensor 77



Accessories 77

Particle Monitor 78 - 81



LPM-II-plus 78



Interface-LPM-II-USB/ETH 79



DISPLAY-LPM-II-plus-REMOTE 79



Flow Control Valve 80

DAV-LPM-II



ATEX Device 81

LPM-II- ... -CX

Oil Sampling 82



Oil Sampling Kit 82

KIT-SFS-1/-2

Introduction Particle Counting



Fluid analysis is a crucial element in any oil management programme. Early detection of potential faults avoids costly repairs and breakdowns.

STAUFF offers a world-leading range of the most advanced and versatile particle counters for every conceivable application. Whether in stationary systems or as a portable solution for mobile machines, they can be customised precisely to the application thanks to their wide range of options.

The various device types offer very fast, comprehensive and very accurate particle analysis for different applications.

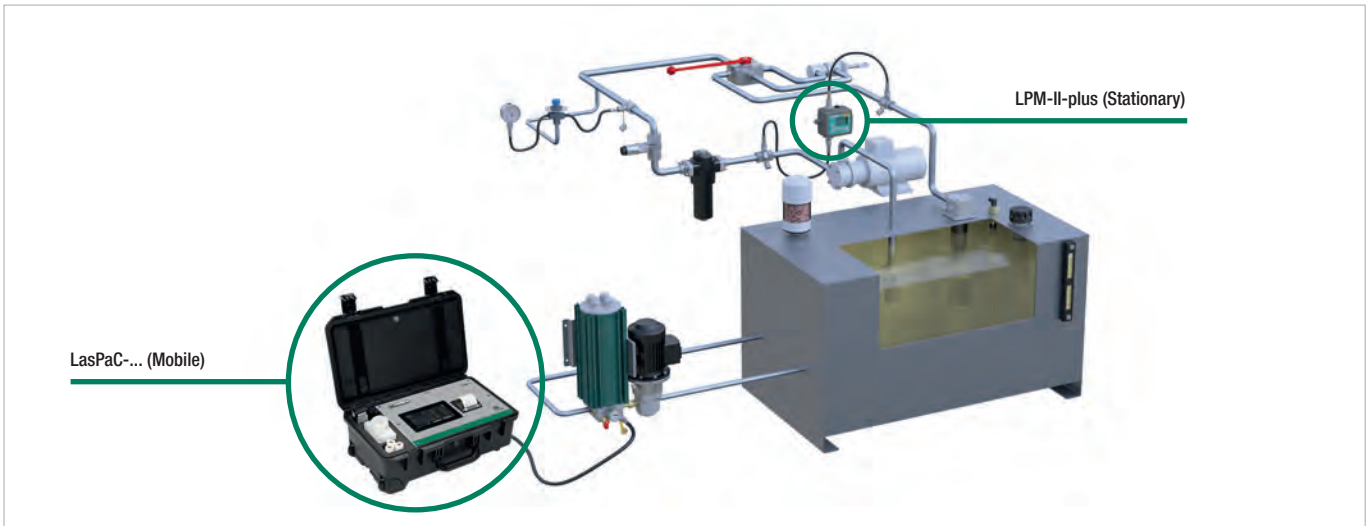
Due to their design, the particle counters are extremely robust and adapted to the adverse conditions in the hydraulic environment.

Particle counting provides measurement results in accordance with all current international standards (ISO, NAS and SAE) and includes further analyses such as moisture, temperature and pressure measurement.

Real-time monitoring and proactive maintenance protects the machines, increases performance and productivity and reduces costs and unplanned downtime.

Testing standards and oil purity

C



Application examples of particle counters in the hydraulic circuit

Testing standards and oil purity

In order to guarantee reliable operation for years to come, certain components must comply with a specified oil cleanliness class.

The required oil cleanliness class is determined by the most sensitive system component.

Particle counters are used, for example, to measure oil purity in accordance with ISO 4406. The particle counters are used to count the number of particles >4 μm(c), >6 μm(c) and >14 μm(c) in 100 ml of hydraulic oil. The number of particles is then assigned to a classification number (e.g. 14/11/8), which then corresponds to the ISO cleanliness class.

This classification is carried out automatically in the particle counter and evaluated according to the standards below, among others.

When interpreting these classes, it should be noted that the number of particles is doubled for each next higher class.

The STAUFF particle counters are calibrated with ISO test dust (ISO Medium Test Dust / ISO MTD) in accordance with ISO 11 171.

Cleanliness classes according to ISO 4406

Number of particles in 100 ml		Classification numbers ISO 4406		
More than	Less than	> 4 μm(c)	> 6 μm(c)	> 14 μm(c)
16000000	32000000	25	25	25
8000000	16000000	24	24	24
4000000	8000000	23	23	23
2000000	4000000	22	22	22
1000000	2000000	21	21	21
500000	1000000	20	20	20
250000	500000	19	19	19
130000	250000	18	18	18
64000	130000	17	17	17
32000	64000	16	16	16
16000	32000	15	15	15
8000	16000	14	14	14
4000	8000	13	13	13
2000	4000	12	12	12
1000	2000	11	11	11
500	1000	10	10	10
250	500	9	9	9
130	250	8	8	8
64	130	7	7	7
32	64	6	6	6
16	32	5	5	5

Cleanliness classes according to NAS 1638

Class	Number of particles 100 ml [μm]				
	5 – 15	15 – 25	25 – 50	50 – 100	>100
00	125	22	4	1	0
0	250	44	8	2	1
1	500	89	16	3	1
2	1000	178	32	6	1
3	2000	356	63	11	2
4	4000	712	126	22	4
5	8000	1425	253	45	8
6	16000	2850	508	90	16
7	32000	5700	1012	180	32
8	64000	11400	2052	360	64
9	128000	22800	4050	720	128
10	256000	45600	8100	1140	256
11	512000	91200	16200	2880	512
12	1024000	182000	32400	5760	1024

The methods for determining oil purity and the assignment of cleanliness classes are defined in ISO 4406 and NAS 1638. The main difference between these two standards is that ISO and NAS define the size of the particles differently.

Overview of particle counters

Mobile

Stationary



LasPaC-3 in mobile application



LPM-II-plus in stationary application

Version/Design	Mobile		Stationary
Type	LasPaC-3-P	LasPaC-II-M	LPM-II-plus
Measuring range	8 Channels (4,6,14,21,25,38,50,70 µm(c))	8 Channels (4,6,14,21,25,38,50,70 µm(c))	8 Channels (4,6,14,21,25,38,50,70 µm(c))
Compatible with	Fluids based on mineral oil and petroleum, Specific water glycols, bio-oils or phosphate esters	Fluids based on mineral oil and petroleum, Specific water glycols, bio-oils or phosphate esters	Fluids based on mineral oil and petroleum, Specific water glycols, bio-oils or phosphate esters
Moisture Sensor	optional	optional	optional
Viscosity range	1 ... 400 cSt	1 ... 400 cSt	1 ... 1000 cSt
Pressure range (bar)	2 ... 420 bar / 29 ... 6091 PSI	2 ... 420 bar / 29 ... 6091 PSI	2 ... 420 bar / 29 ... 6091 PSI
Measuring point pressure sensor	optional	-	-
Display	7" Touchscreen	LCD display	LCD display
Printer	integrated	-	-
Data storage	integrated (for about 4000 measurements)	integrated (for about 600 measurements)	integrated (for about 4000 measurements)
PC-Interface	USB-C	RS-232 (USB converter incl.)	USB (via USB interface)
Direct connection of USB stick	integrated	-	optional
SPS / PLC connection	-	-	RS485, RS232, Modbus, CAN Bus
Analogue output	-	-	4 - 20 mA (See data sheet for details)
Power supply	Battery pack integrated Li-Ion or 110/220V	Battery pack integrated NiMH or 110/220 V	9 - 36VDC or 110V/230V optional
Page	70	74	78



Analyses anywhere - bottle sampling unit

If it is not possible to count particles directly on your system, you can use the oil sampling kit (page 82) to take oil samples for later analysis with the LasPaC bottle sampler.

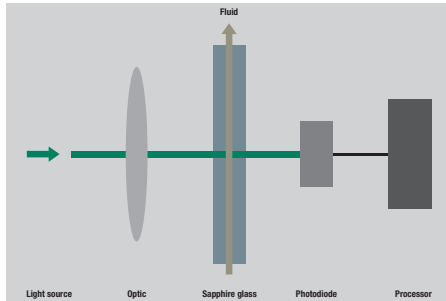
Please see page 76

Particle counting in general

Operating principle

All STAUFF particle counters work according to the light-blockade principle, in which LEDs shine through the liquid to be measured and illuminate a photodiode.

When a particle in the oil passes the light beam, the amount of light that hits the photodiode decreases. As this change is directly proportional to the size of the particle, the degree of contamination can be determined from this.



For all applications - High compatibility

Depending on the model, STAUFF particle counters are compatible with mineral oils and petroleum-based fluids, phosphate esters (e.g. Skydrol®) or specific water glycols and specific bio-oils.

For every type of application - Large pressure range

A major advantage of STAUFF particle counters is the wide application pressure range from 2 bar / 29 PSI to 420 bar / 6091 PSI. This leads to reliable measurement results without the need for additional devices.

Moisture / Temperature Sensor

The STAUFF particle counters can also be equipped with a moisture / temperature sensor.

This sensor measures the water content of the measured fluid (results in relative humidity, RH%) and also indicates the current fluid temperature (in °C).

Further information can be found on page 77.

Please note that the moisture / temperature sensor cannot be used with phosphate esters (e.g. Skydrol®), water-glycol fluids and bio-oils.

Calibration according to ISO 11 171

The STAUFF particle counters are calibrated with ISO test dust (ISO Medium Test Dust / ISO MTD) in accordance with ISO 11 171.

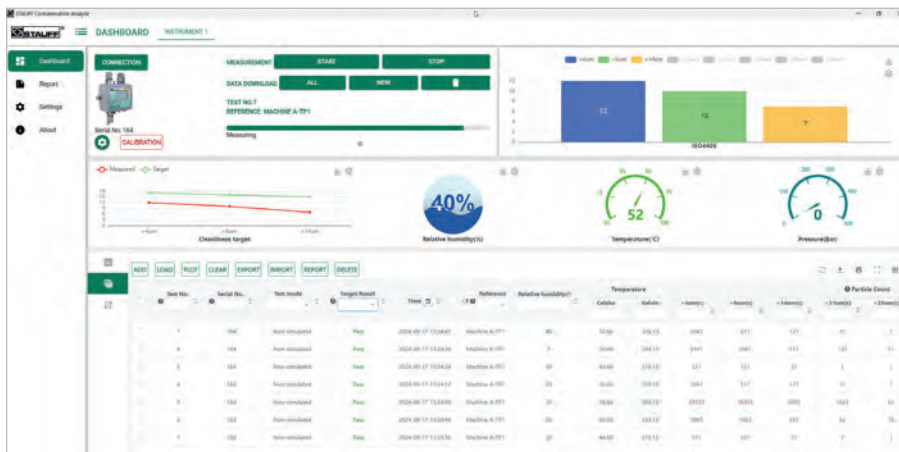
The cleanliness classes are analysed according to the various standards used. These include ISO 4406, NAS 1638, AS 4059 / ISO 11218 Rev E and F, GBT 14039 and GJB 420B.

Bottle Sampling Unit

Fluids that are heavily mixed with air cannot be measured correctly. To remedy this, the bottle sampling unit has a vacuum pump that removes air from the oil sample. The bottle sampling unit is supplied in both sizes (110 ml and 500 ml) with an external power supply. For further information please see page 76.

Please note that the moisture / temperature sensor mentioned above cannot be operated in conjunction with the bottle sampling unit.

PC software for LasPaC and LPM STAUFF Contamination Analyze



Measurement data view in table form

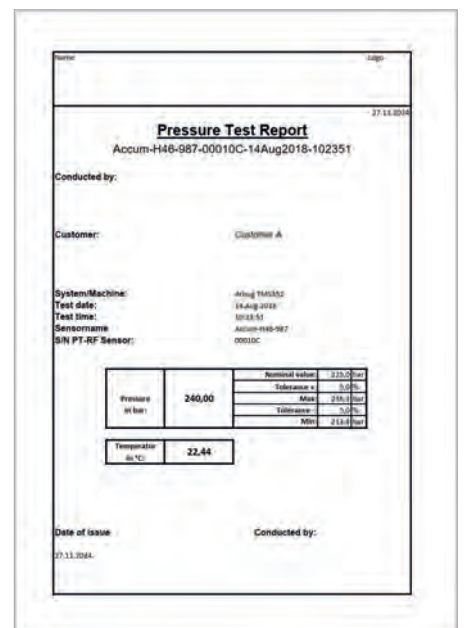


Viewing trends directly in the software

Using the software supplied, the measurement data stored on the devices can be visualised and evaluated. The software works on a database basis, which makes it easy for the user to obtain an overview of the cleanliness classes of their machines and systems. Trends and threshold values can be read off simply and easily.

By creating report templates, reports for customers or your own documents can be created very easy. It is possible to store logos and addresses. This allows the report to be optimised for your own service.

All particle counters or monitors supplied by STAUFF can be read out with the same software, so that even a comparison of different measuring devices is possible.



Create customised reports

Particle Counter ■ Type LasPaC-3-P (Professional)



Robust design (co-polymer housing)



Modern 7" touchscreen and thermal printer



Mobile due to integrated trolley function

Product Description

The LasPaC-3 sets new standards in particle measurement. The third generation mobile laboratory simply on site. Fast, precise, robust and reliable.

Features

Works fast

Fast generation of measurement results due to free programmable test volume (100 ml in one minute)

According to international standards

ISO 4406, NAS 1638, AS 4059 / ISO 11218 Rev E and F, GBT 14039 and GJB 420B

Additional oil moisture measurement incl. temperature monitoring

Optional moisture sensor (results in relative humidity, RH%) with integrated temperature measurement (°C)

Sample size according to requirements

Sample size free selectable up to 100ml

Connect to the working system

Pressure range from 2 to 420 bar.
Optional, integrated measuring point pressure sensor

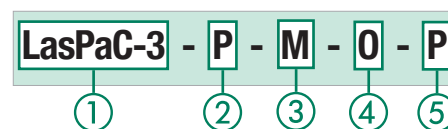
Mobile and robust

Robust construction (co-polymer housing) with still lowest weight, mobile due to integrated trolley function. All necessary connections, hoses and waste oil bottle integrated in the case.

Various measurement modes

Measuring modes adapted to the measuring task:
Simple, continuous, bottle sampler

Order Codes



① Series and Type

Particle Counter **LasPaC-3**

② Version

Professional **P**

③ Fluid Compatibility

Mineral Oil, Petroleum based fluids	M
Phosphate Ester (e.g. Skydrol®)	E
Specific Water Glycol fluids and bio-oils	G

Note: If you have any queries on fluid compatibility, please contact STAUFF.

④ Moisture/ Temperature Sensor

Without moisture/ temperature sensor	0
With moisture/ temperature sensor	W

Please note: Not suitable for Phosphate Ester (e.g. Skydrol®), Glycol fluids and bio-oils.

⑤ Measuring point pressure sensor

Without Measuring point pressure sensor	0
With Measuring point pressure sensor	P

Long battery life

Long-life Li-Ion battery enables self-sufficient operation directly at the measuring point. Easy battery removal for air freight transportation possible.

Integrated self-cleaning

Automatic program for sensor cleaning



Waste oil bottle

The sample oil can be collected in the integrated waste oil bottle and disposed later.

Simple operation

Via 7" touchscreen with intuitive menu navigation

Direct documentation

Printout of the results including particle counts directly using the integrated printer or permanently due to internal storage for measurement result

Particle Counter - Type LasPaC-3-P (Professional)



Connections



Integrated Organizer

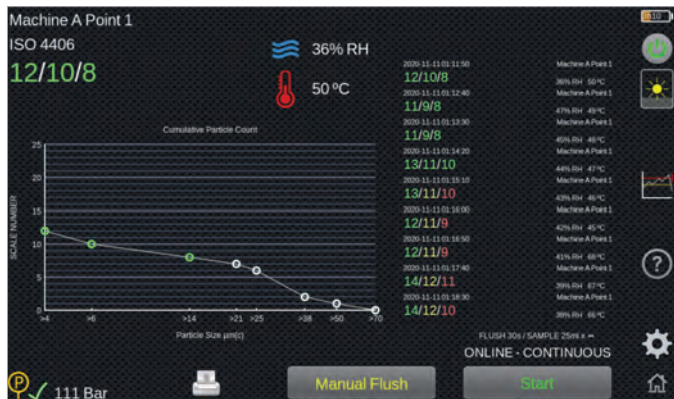


Thermal printer printouts directly

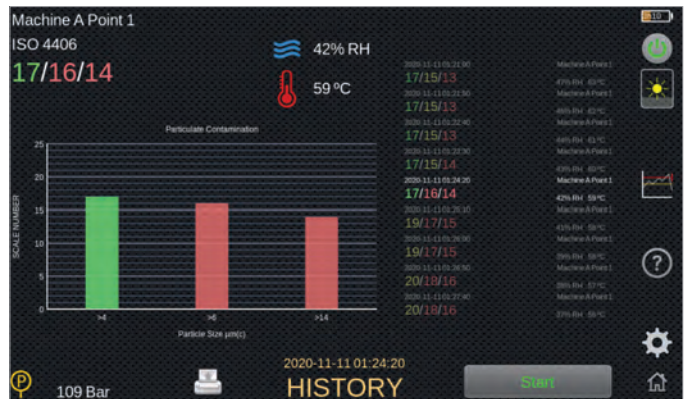
C

Extensive analysis functions

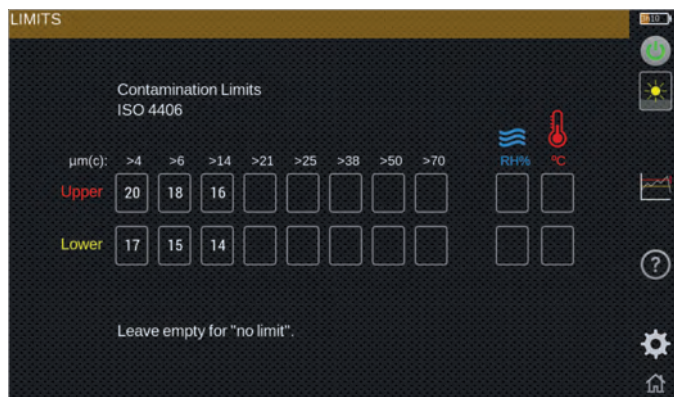
The measurement data can be analyzed and evaluated on the screen (RED/YELLOW/GREEN/BLUE) or transferred to the PC software for further processing via USB-C.



- Measured value display directly in the diagram



- Historical data always available and quickly retrievable



- Definition of limit values, directly in the device
- Visual coloring when measured values are exceeded



- Simple setting of measurement tasks

Particle Counter ■ Type LasPaC-3-P (Professional)



Technical Data

Dimensions and Weight

- L/W/H: 551 x 358 x 226 mm /
21.69 x 14.09 x 8.90 in
- Weight: 15,5 kg / 34.17 lbs

Display / Printer

- Display: 7" touchscreen
- Printer: Thermal printer

Power Supply

- Voltage range: 110 ... 240 V AC
- European, UK and US power plug adaptors included
- Number of tests before recharging is required: 100
- Removable Li-Ion battery pack

Calibration

- ISO Medium Test Dust (MTD) according to ISO 11 171

Analysis range

- ISO 4406 Codes 0-24
- NAS 1638 Classes 00-12
- AS 4059 / ISO 11218 Rev E, Table 1 Codes 00-12
- AS 4059 / ISO 11218 Rev E, Table 2 Codes A-F: 000-12
- AS 4059 Rev F, Table 1 Codes 000-12
- AS 4059 Rev F, Table 2 Codes cps 000-12
- GBT 14039 Codes 0-24
- GJB 420B Codes, A-F: 000-12

Accuracy

± 1/2 class for:
ISO 4406 and GBT 14039 Codes 8-24 and for Codes 4, 6, 14 $\mu\text{m(c)}$,
NAS 1638 and AS 4059 / ISO 11218 Rev E and F,
Table 1 Size Codes Class 2-12,
AS4059 / ISO 11218 Rev E and F Table 2 and GJB 420B Size
classes, A: 000-12, B: 00-12, C: 00-12, D: 2-12, E: 4-12,
F: 7-12

± 1 class for larger sizes and lower size codes as mentioned
above

Pressure / Viscosity

- Pressure range: 2 ... 420 bar /
29 ... 6091 PSI
- Viscosity range: 1 ... 400 cSt

LED Sensor

- High accuracy laser LED: Automatic optical particle counter with high-precision LED light blockage
- Measured channels: 4, 6, 14, 21, 25, 38, 50, 70 $\mu\text{m}_{(e)}$
- The maximum concentration is ISO 4406 Code 24 (160.000 p/ml)
- Sample quantity: Maximum 100 ml per pump stroke
Programmable test volume

Moisture Sensor (optional)

- % RH (relative humidity) ± 3 %
- ± 3 °C / ± 32 °F

Measuring point pressure sensor (optional)

- $\pm 0.5\%$ full scale accuracy (min. 10 bar)

Accessories

- Bottle Sampling Unit 110 ml
- Bottle Sampling Unit 500 ml
- For further information please see on page 76.
- Screen filter: 500 μm (see on page 77)

Hose Connections

- In: Test points STAUFF Test 20 or similar (M16 x 2)
1.5 m hose included in the scope of delivery
- Out: Quick-release coupling (unpressurised)
2 m hose included in the scope of delivery

Permissible Temperature

- Media temperature: +5 °C ... +80 °C / +41 °F ... +176 °F
- Ambient temperature: -10 °C ... +80 °C / +14 °F ... 176 °F
- Rel. humidity: < 80%

Data output

- 2 x USB output: 1 x USB-C for connection to PC
1 x USB-A for data download to USB memory stick

Data Storage

- for 4000 tests

Fluid Compatibility

- Mineral Oil, Petroleum based fluids
- Specific water glycols, bio-oils or phosphate esters

Protection class

- IP 66 (closed cover)
- IP 54 (open cover)

Software

- Downloading and storage of data using the 'STAUFF Contamination Analyze' software supplied. Further processing with Microsoft Excel® possible.

Particle Counter ▪ Type LasPaC-II-M (Mobile)



LasPaC-II-M with integrated battery (standard option)



LasPaC-II-M also available without integrated battery

Product Description

The LasPaC-II-M (mobile) is a simplified particle counter that has been specially designed for applications where it is important to have a lightweight and robust service device.

Features

According to international standards

ISO 4406, NAS 1638, AS 4059 / ISO 11218 Rev E and F, GBT 14039 and GJB 420B

Additional oil moisture measurement incl. temperature monitoring

Optional moisture sensor (results in relative humidity, RH%) with integrated temperature measurement (°C)

Simple operation

Intuitive three-button operation (start, stop, flush)

Display

LCD-Screen for ISO / NAS-Class

Documentation

Data Storage for 600 tests. Downloading and storage of data using the 'STAUFF Contamination Analyze' software supplied. Further processing with Microsoft Excel® possible.

Connect to the working system

Pressure range from 2 to 420 bar

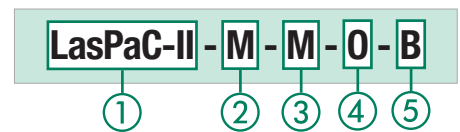
Mobile and robust

Robust construction (co-polymer housing) with still lowest weight. All necessary connections, hoses and waste oil bottle integrated in scope of delivery.

Various measurement modes

Measurement modes adapted to the measuring task can be selected using the "STAUFF Contamination Analyze" software

Order Codes



① Series and Type

Particle Counter	LasPaC-II
------------------	-----------

② Version

Mobile	M
--------	---

③ Fluid Compatibility

Mineral Oil, Petroleum based fluids	M
Phosphate Ester (e.g. Skydrol®)	E
Specific Water Glycol fluids and bio-oils	G

Note: If you have any queries on fluid compatibility, please contact STAUFF.

④ Moisture/ Temperature Sensor

Without moisture/ temperature sensor	0
With moisture/ temperature sensor	W

Please note: Not suitable for Phosphate Ester (e.g. Skydrol®), Glycol fluids and bio-oils.

⑤ Battery

With internal rechargeable battery	B
Without internal rechargeable battery	0

Particle Counter ■ Type LasPaC-II-M (Mobile)



LasPaC-II-M with small Bottle Sampler



Display and Buttons

Technical Data
Dimensions and Weight

- L/W/H: 340 x 295 x 152 mm /
13.40 x 11.61 x 5.98 in
- Weight: 4,75 kg / 10.47 lbs

Power Supply

- Voltage range: 110 ... 240 V AC
12 ... 24 V DC
- European, UK and US power plug adaptors included
- Number of tests before recharging is required: 60

Calibration

- ISO Medium Test Dust (MTD) according to ISO 11 171

Analysis range

- ISO 4406 Codes 0-24
- NAS 1638 Classes 00-12
- AS 4059 / ISO 11218 Rev E, Table 1 Codes 00-12
- AS 4059 / ISO 11218 Rev E, Table 2 Codes A-F: 000-12
- AS 4059 Rev F, Table 1 Codes 000-12
- AS 4059 Rev F, Table 2 Codes cps 000-12
- GBT 14039 Codes 0-24
- GJB 420B Codes, A-F: 000-12

Accuracy

± 1/2 class for:
ISO 4406 and GBT 14039 Codes 8-24 and for Codes 4, 6, 14 μm(c),
NAS 1638 and AS 4059 / ISO 11218 Rev E and F,
Table 1 Size Codes Class 2-12,
AS4059 / ISO 11218 Rev E and F Table 2 and GJB 420B Size
classes, A: 000-12, B: 00-12, C: 00-12, D: 2-12, E: 4-12,
F: 7-12

- ± 1 class for larger sizes and lower size codes as mentioned above

Pressure / Viscosity

- Pressure range: 2 ... 400 bar / 29 ... 5801 PSI
- Viscosity range: 1 ... 400 cSt

Laser Sensors

- High accuracy laser: 4 ... 6 μm_(c)
- Standard accuracy laser: 6 ... 70 μm_(c)
- Measured channels: 4, 6, 14, 21, 25, 38, 50, 70 μm_(c)
- The maximum concentration is ISO 4406 Code 24 (160.000 p/ml)

Accessories

- Bottle Sampling Unit 110 ml
- Bottle Sampling Unit 500 ml
- For further information please see on page 76.
- Screen filter: 500 μm (see on page 77)

Hose Connections

- In: Test points STAUFF Test 20 or similar (M16 x 2)
1.5 m hose included in the scope of delivery
- Out: Quick-release coupling (unpressurised)
2 m hose included in the scope of delivery

Sample Volume

- 8 ml (short)
- 15 ml (normal)
- 30 ml (dynamic)
- 24 ml (bottle sampler)
- 15 ml (continuous)

Permissible Temperature

- Operating: +5 °C ... +80 °C / +41 °F ... +176 °F
- Rel. humidity: < 80%

Data Storage

- 600 tests

Fluid Compatibilit

- Mineral Oil, Petroleum based fluids
- Specific water glycols, bio-oils or phosphate esters

Computer Interface

- RS-232 communication port as standard
- USB adaptors included

Software

- Downloading and storage of data using the 'STAUFF Contamination Analyze' software supplied. Further processing with Microsoft Excel® possible.

Internal Rechargeable Battery

- As an option with internal rechargeable battery

Bottle Sampling Unit ▪ Typ Bottle-Sampler-LasPaC



Bottle Sampling Unit 110 ml and Accessories



Bottle Sampling Unit 110 ml



Bottle Sampling Unit 500 ml

Product Description

Analysis Everywhere - Bottle Sampling Unit

If it is not possible to count particles directly on your system, you can use the oil sampling kit (page 82) to take oil samples for later analysis with the LasPaC bottle sampler.

Conditioning - The De-aeration Facility

A highly aerated fluid may lead to inaccurate results; therefore a de-aeration process has been incorporated into the bottle sampling units.

By evacuating the air from the sampling chamber, aeration within the fluid is removed, and the fluid is properly conditioned prior to sampling.

Your Choice - 110 ml or 500 ml Size

STAUFF offers two sizes of bottle sampling units for the LasPaC devices: 110 ml and 500 ml units.

The 110 ml unit is supplied in an extra case including various accessories such as power supply, sampling hoses, pressure hoses, bottles (sample and waste) and adaptors. It is designed for mobile applications and is only compatible with Mineral Oil and Petroleum based fluids.

The 500 ml bottle sampling unit is delivered with five sample bottles and the required power supply.

Please note that the moisture / temperature sensor does not work in combination with bottle sampler devices.

Order Codes

Bottle-Sampler-LasPaC - 110-M

①

②

① Series and Type

Bottle Sampling Unit	Bottle-Sampler-LasPaC
----------------------	------------------------------

② Unit

110 ml Bottle Sampling Unit suitable for Mineral Oil and Petroleum based fluids only	110-M
500 ml Bottle Sampling Unit suitable for Mineral Oil and Petroleum based fluids, Specific Water Glycol fluids and bio-oils	500-M/G
500 ml Bottle Sampling Unit suitable for Phosphate Ester (e.g. Skydrol®)	500-E

Moisture / Temperature Sensor

Product Description

Saturation Levels

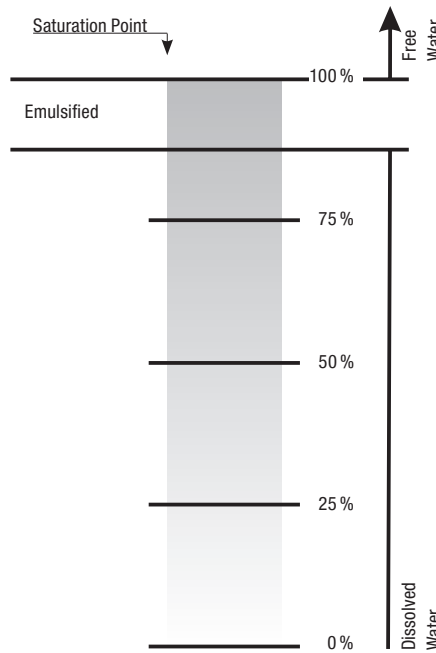
Since the effects of free (also emulsified) water are more harmful than those of dissolved water, water levels should remain always well below the saturation point.

However, even water in solution can cause damage, and therefore every reasonable effort should be made to keep saturation levels as low as possible.

There is no such thing as too little water. As a guideline, we recommend maintaining saturation levels below 50% in all equipment.

Different oils have different saturation levels, and % saturation is the best and most practical measurement.

These results can be converted to ppm (parts per million), if the oil type saturation / temperature characteristic is known.



More Oil Analysis - Oil Saturation and Temperature

In Mineral Oils and non-aqueous fire resistant fluids, water is undesirable. Once the water exceeds a saturation level (about 500 ppm for Mineral Oils) the fluid starts to appear hazy. Above this level there is a danger of free water accumulating in the system. This can lead to corrosion and accelerated wear.

As an option, all STAUFF Particle Counters provide accurate and repeatable measurement of the saturation level of water in oil with the moisture / temperature sensor. The sensor is located internally in a specially designed housing and is positioned in the low pressure constant flow line.

Additional Information - Oil Temperature Readings

Beside the saturation level the optional moisture / temperature sensor of the STAUFF Particle Counters has the ability to measure the fluid temperature. This allows to provide a reference temperature for the RH (relative humidity / % saturation of water in oil) readings.

Both results, % RH and °C, are displayed on the main / test progress screen and on the printed analysis.

Please note: Due to the temperature gradient existing between the system tapping point and the RH / temperature module, the temperature reading can be 5° to 10° less than the actual system temperature, depending on operating conditions. The moisture / temperature sensor is not suitable for bottle sampling.

Product Description: Screen Filter ▪ Type Screen-Filter-LasPaC



An optional Screen Filter is available for heavily contaminated systems. The filter device is assembled directly to the supply line and allows particle counts in ambient conditions where normally the contamination is too high for a reliable test.

The Stainless Steel Filter has a mesh of 500 µm and is cleanable.

Order Codes

Particle Counter ▪ Accessories

Accessories / Spare Parts



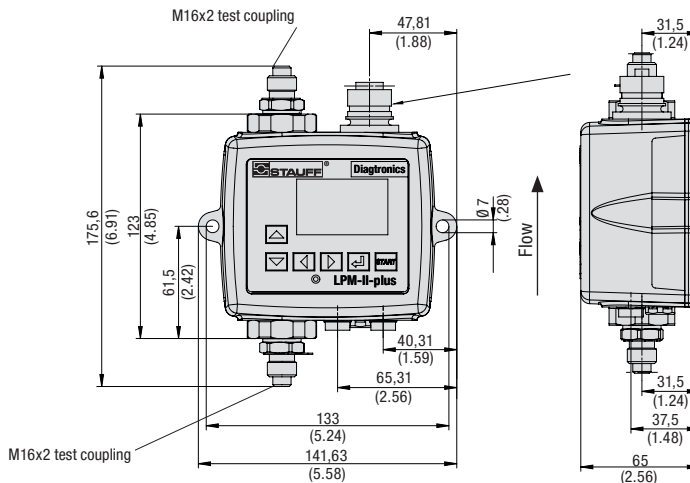
① Type of Accessories / Spare Parts

Waste hose 2 m / 6.56 ft	Hose-LasPaC-Waste-2m
Pressure hose 1,5 m / 4.92 ft	SMS-20-1500-A-W3
110 ml certified clean* bottle (5 pieces)	Set-Bottle-LasPaC-110-C
250 ml certified clean* bottle (5 pieces)	Set-Bottle-LasPaC-250-C
110 ml glass sample bottle (5 pieces)	Set-Bottle-LasPaC-110
250 ml glass sample bottle (5 pieces)	Set-Bottle-LasPaC-250
500 ml glass sample bottle (5 pieces)	Set-Bottle-LasPaC-500
Printer paper LasPaC-II-P (5 pieces)	Set-Paper-LasPaC-II-Printer
Printer paper LasPaC-3-P (5 pieces)	Set-Paper-LasPaC-3-Printer
RS 232 to USB converter	Adaptor-PPC-04/12-RS232-to-USB-CAB
Screen filter (for Mineral Oil/Petroleum based fluids, specific Water Glycol fluids, bio-oils)	Screen-Filter-LasPaC-M/G
Screen filter (for Phosphate Ester)	Screen-Filter-LasPaC-E



* Cleaned in accordance with DIN/ISO 5884 and verified to ISO 3722 with a NAS 1638 cleanliness of between Class 00 and 0.

Particle Monitor - LPM-II-plus



Product Description

The LPM-II-plus Particle Monitor determines the contamination level of the measured fluid on eight size channels and offers precise and complete determination of particle sizes in accordance with international standards.

The LPM-II-plus is an automatic, optical particle counter with high-performance LEDs that work on the light obscuration principle. STAUFF recommends recalibrating the measuring equipment at regular intervals.

- Multicolour indicators via LCD and LED with output alarm signals as standard
- Two switching outputs for customer-specific limit values
- 4-20mA analogue output as standard (time multiplex)

Options

- Moisture sensor / temperature sensor: RH in % (relative humidity) and temperatures in °C
- USB Port for Data transfer (optional)

Technical Data

Channels

- 4, 6, 14, 21, 25, 38, 50, 70 µm(c)

Calibration

ISO Medium Test Dust (MTD) in accordance with ISO 11171

Analysis range

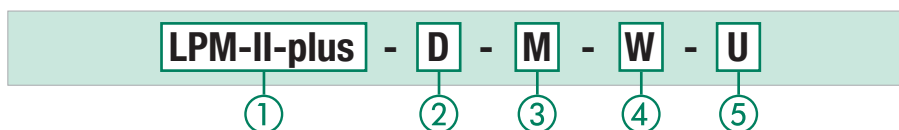
- ISO 4406 Codes 0-24
- NAS 1638 Classes 00-12
- AS 4059 / ISO 11218 Rev E, Table 1 Codes 00-12
- AS 4059 / ISO 11218 Rev E, Table 2 Codes A-F: 000-12
- AS 4059 Rev F, Table 1 Codes 000-12
- AS 4059 Rev F, Table 2 Codes cps 000-12
- GBT 14039 Codes 0-24
- GJB 420B Codes, A-F: 000-12

Accuracy:

± 1/2 class for: ISO 4406 and GBT 14039 Codes 8-24 and for Codes 4, 6, 14 µm(c), NAS 1638 and AS 4059 / ISO 11218 Rev E and F, Table 1 Size Codes Class 2-12, AS4059 / ISO 11218 Rev E and F Table 2 and GJB 420B Size classes, A: 000-12, B: 00-12, C: 00-12, D: 2-12, E: 4-12, F: 7-12

± 1 class for larger sizes and lower size codes as mentioned above

Order Codes



① Series and Type

Particle Monitor (Incl. LPM-II-CAB-P-FL-3 connecting cable) **LPM-II-plus**

② Version

With display and keypad **D**
Without display and keypad **0**

③ Fluid Compatibility

Fluids based on Mineral Oil and Petroleum **M**
Phosphate Ester (e.g. Skydrol®) **E**
Specific Water Glycols and bio-oils **G**

Note: If you have any queries on fluid compatibility, please contact STAUFF.

④ Moisture Sensor / Temperature Sensor

Without moisture sensor / temperature sensor **0**
With moisture sensor / temperature sensor **W**

Please note: Not suitable for Phosphate Ester (e.g. Skydrol®), Water Glycol fluids and bio-oils.

⑤ Interface

USB interface to transfer measured data to a data carrier **U**

Note: In the case applications with extreme pressure peaks, please contact STAUFF.

Note: You need an interface module with either a USB or an Ethernet interface for exporting and programming.

Flow

- 20 ... 400 ml/min / 0.005 ... 0.11 US GPM

Viscosity Range

- ≤ 1000 mm²/s

Medium Temperature

- -25 °C ... +80 °C / -13 °F ... +176 °F

Ambient Temperature

- LPM II-O: -25 °C ... +80 °C / -13 °F ... +176 °F
- LPM II-D: -25 °C ... +55 °C / -13 °F ... +131 °F
- Rel. humidity: < 80%

Weight

- 1,6kg / 3.53 lbs

Max. Pressure

- 420 bar / 6091 PSI static
- Note: In systems with extreme pressure peaks, please contact STAUFF

Test Duration

- Settable between 10 ... 3600 sec., set ex-works to 120 sec.
- As standard with start delay and freely programmable test intervals

Moisture Sensor / Temperature Sensor

- % RH (relative humidity) ±3 %
- ±3 °C / ±2 °F

Volumetric Flow Measurement

- As display only

Hose Connections

- Test coupling STAUFF Test 20 or comparable (M16 x 2)

Data Storage

- Max. 4000 measuring results

Interfaces

- RS485, RS232, Modbus, CAN Bus
- 4-20 mA time multiplex interface
- USB interface to transfer measured data to a data carrier (optional)

International Protection Rating

- IP 65/67: Dust-proof and protected from spray
- Impact resistance rating IK04

Power Supply / Power

- 9 ... 36 V DC, < 2.2 W (connecting cable with flying leads is included)

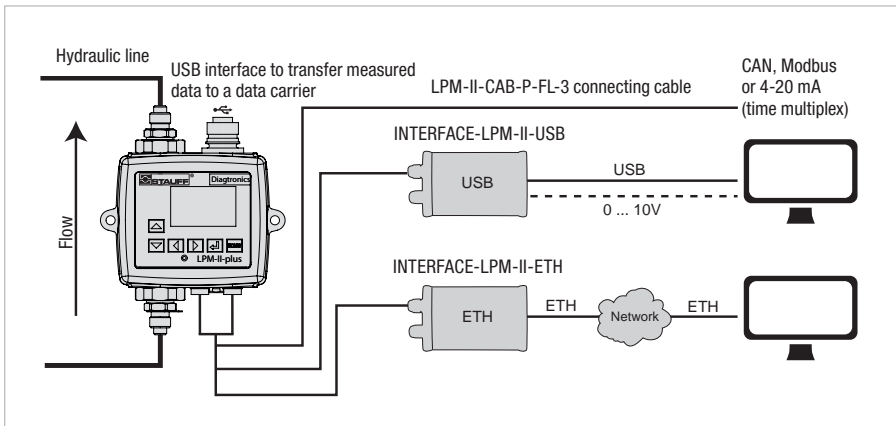
Current Consumption

- 12 V: 70 mA (LPM-II-plus-O), 150 mA (LPM-II-plus-D)
- 24 V: 40 mA (LPM-II-plus-O), 80 mA (LPM-II-plus-D)
- 36 V: 30 mA (LPM-II-plus-O), 60 mA (LPM-II-plus-D)

Housing Surface Treatment

- Polyurethane based paint, according to BSX34 colour BS381-638 (dark sea grey)
- Tested according to: BS2X34A and BS2X34B, MMO114 and SP-J-513-083 Part II. Cl. A
- The unit meets: MIL-PRF-85285

Interface Module with USB or Ethernet Interface ▪ INTERFACE -LPM-II-USB/ETH



Connection diagram: PC connection of the LPM-II-plus Particle Monitor

Order Code

INTERFACE-LPM-II-USB



① Series and Type

Interface module with USB interface **INTERFACE-LPM-II-USB**
 Interface module with USB interface and 0-10V analogue outputs **INTERFACE-LPM-II-USB-010V**

Scope of supply:

- Power supply unit
- Interface module with USB interface
- Connecting cable (3 m / 9.84 ft)
- USB cable

Order Code

INTERFACE-LPM-II-ETH



① Series and Type

Interface module with Ethernet interface **INTERFACE-LPM-II-ETH**

Scope of supply:

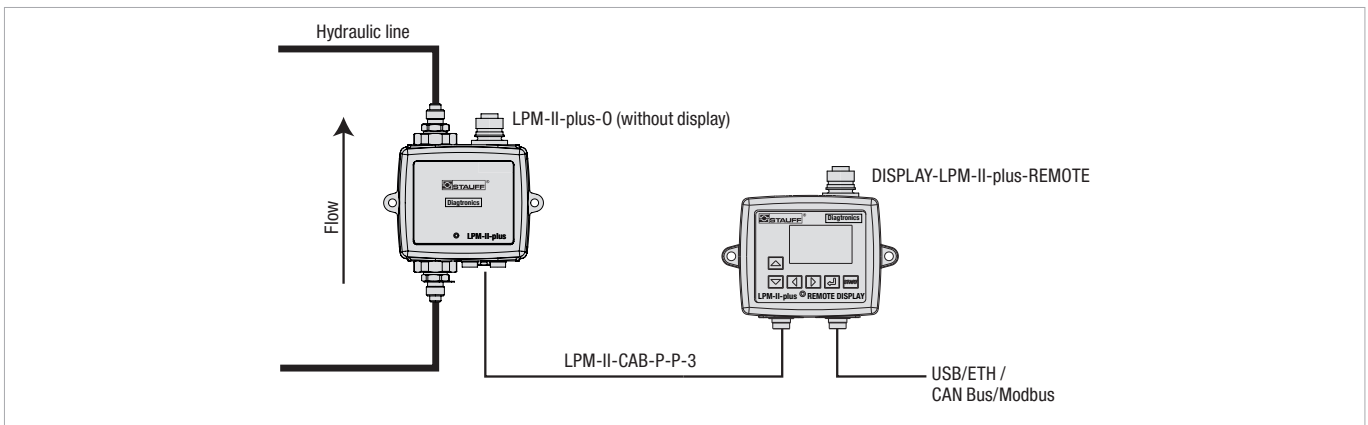
- Power supply unit
 - Interface module with Ethernet interface
 - Connecting cable (3 m / 9.84 ft)
- Note: An Ethernet cable is not supplied.

Product Description

The LPM-II-plus is connected to an EDP system or a laptop/PC using an interface module with a USB or an Ethernet interface. Either interface module is connected to the LPM-II-plus using a connecting cable (3 m / 9.84 ft). With the power supply unit connected, the LPM-II-plus is supplied with current via the connecting cable. The interface modules allow you to evaluate the measured data and to carry out programming using the supplied software. In USB operation, the LPM-II-plus can be supplied with current via the USB cable too.

The USB interface is optionally also available with additional 0-10 V outputs. The 0-10 V interface provides six ISO channels, the relative humidity and the temperature on eight voltage outputs.

Remote Display Unit ▪ DISPLAY-LPM-II-plus-REMOTE



Connection diagram: Remote display

Order Code

DISPLAY-LPM-II-plus-REMOTE



① Series and Type

Remote Display **DISPLAY-LPM-II-plus-REMOTE**

Scope of supply:

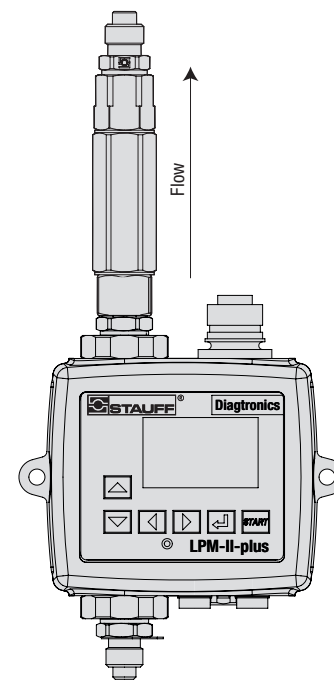
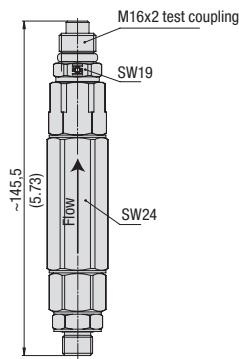
- Remote Display
- LPM-II-CAB-P-P-3 connecting cable

Product Description

In the case of applications outside the operator's field of view or in locations that are difficult to access, it is possible to display via a remote display the values that the LPM-II-plus measured.

Flow Control Valve - DAV-LPM-II

C



Product Description

In systems in which the volumetric flow or the pressure is too high, the optimum flow is achieved with the use of a flow control valve.

It can process pressures from 4 bar ... 400 bar / 58 PSI ... 5801 PSI.

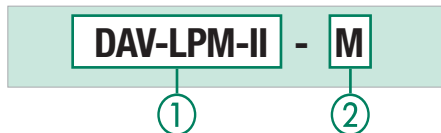
The DAV-LPM-II, flow control valve is connected to the hydraulic outlet of the LPM-II-plus via the connection fittings.

Max. Permissible Operating Pressure

▪ 400 bar / 5801 PSI

Note: Note that a minimum operating pressure of 4 bar / 58 PSI must be maintained for the proper function of the flow control valve.

Order Code



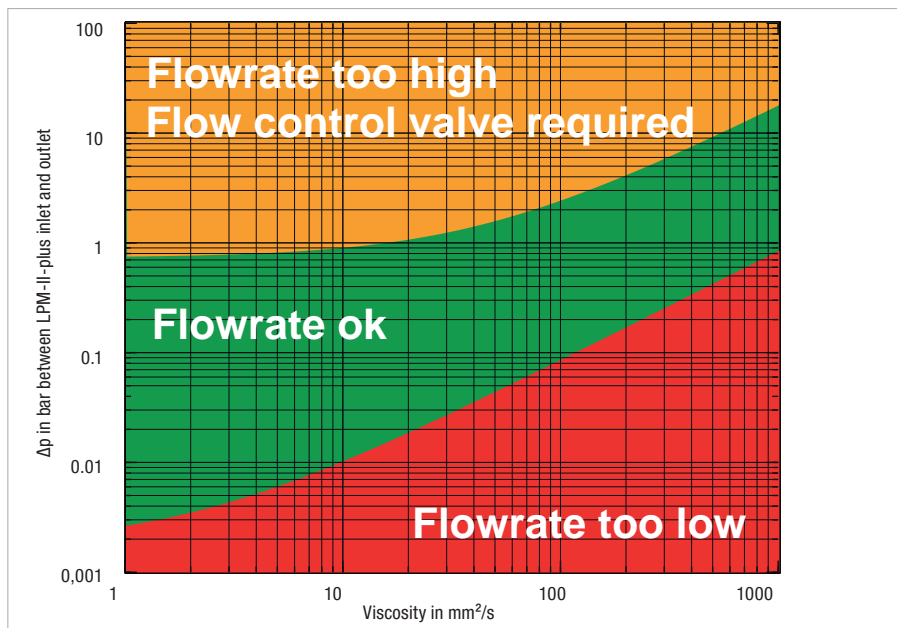
① Series and Type

Flow Control Valve **DAV-LPM-II**

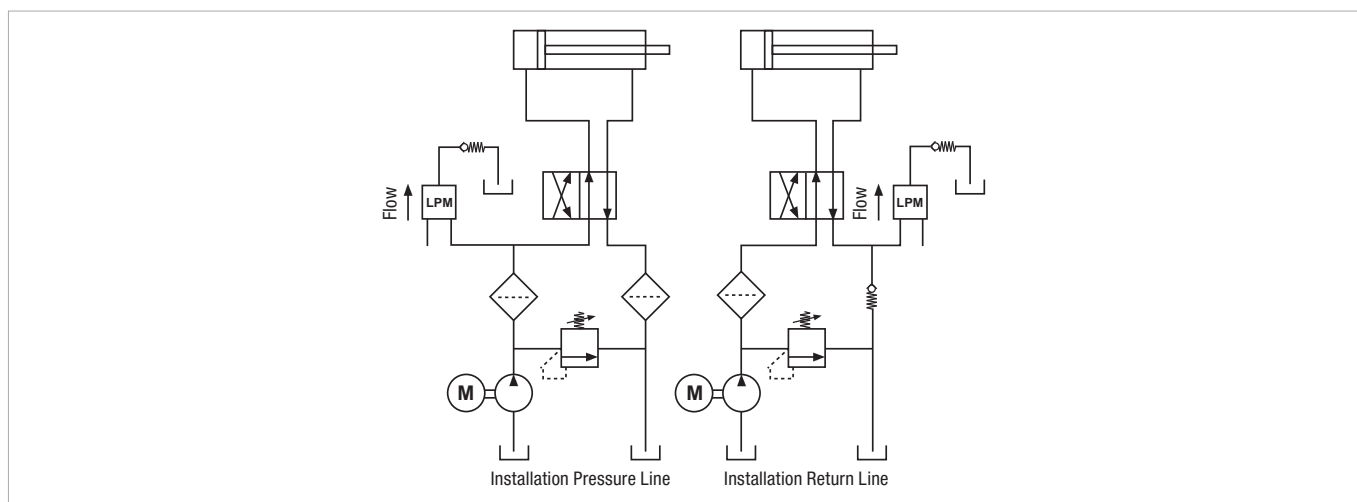
② Fluid Compatibility

Fluids based on Mineral Oil and Petroleum	M
Phosphate Ester (e.g. Skydrol®)	E
Specific Water Glycols and bio-oils	G

LPM-II-plus with flow control valve DAV-LPM-II



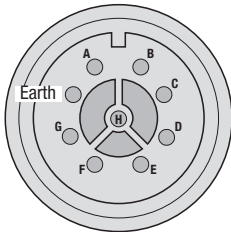
Application example



Particle Monitor ■ LPM-II-...-CX/2

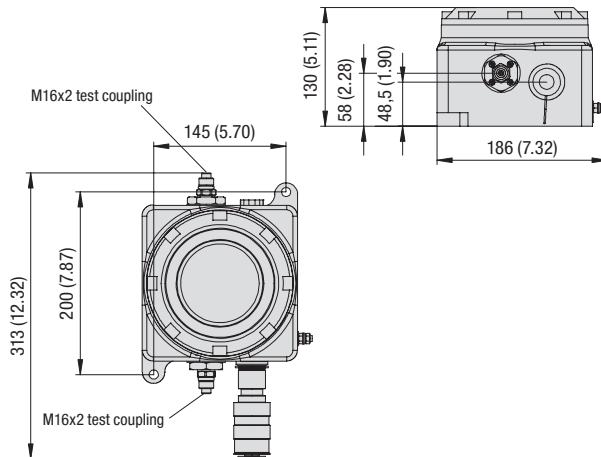
Wiring Diagram

Note: Please note that an ATEX approved connecting cable is not included in the scope of delivery of LPM-II-0-...-CX. A corresponding ATEX plug is included.



View when looking at supplied male connector

- A Data-
- B Data+
- C Power 0V
- D Power +9V-36V DC
- E Output 1
- F Output 2
- G Common
- H Start



Order Codes

LPM-II - D - M - 0 - CX/2

① ② ③ ④ ⑤

① Series and Type

Particle Monitor **LPM-II**

② Version

With display **D**

③ Fluid Compatibility

Fluids based on Mineral Oil and Petroleum **M**
 Phosphate Ester (e.g. Skydrol®) **E**
 Specific Water Glycols and bio-oils **G**

Note: If you have any queries on fluid compatibility, please contact STAUFF.

④ Moisture Sensor / Temperature Sensor

Without moisture sensor / temperature sensor **0**
 With moisture sensor / temperature sensor **W**

Please note: Not suitable for Phosphate Ester (e.g. Skydrol®), Water Glycol fluids and bio-oils.

⑤ Version according to ATEX 94/9/EG

ATEX certification (Zone 2 / Cat. 3G) **CX/2**

Note: You need an interface module with either USB or an ethernet interface for exporting and programming. The USB interface is not ATEX rated.

Product Description

The ATEX version of the Particle Monitor LPM-II is approved for use in hazardous areas (zone 2 / category 3G). The device thus meets the conditions to be used in e.g. oil and gas industry or chemical and process industry.

Product Features

- Determines contamination level of measured fluids in 8 size particle channels
- Precise and complete determination of particle sizes in accordance with international standards
- Integrated data storage for up to 4000 measuring results
- Integrated Modbus and CAN Bus interfaces can be used to connect the device to existing machine control, and data acquisition systems
- Option to specify different alarm thresholds
- Software on CD (included)
- ATEX compliant (Zone 2 / Category 3G)

Technical Data

Channels

- 4, 6, 14, 21, 25, 38, 50, 70 µm(c)

Calibration

ISO Medium Test Dust (MTD) in accordance with ISO 11171

Analysis range

- ISO 4406 Codes 0-24
- NAS 1638 Classes 00-12
- AS 4059 / ISO 11218 Rev E, Table 1 Codes 00-12
- AS 4059 / ISO 11218 Rev E, Table 2 Codes A-F: 000-12
- AS 4059 Rev F, Table 1 Codes 000-12
- AS 4059 Rev F, Table 2 Codes cps 000-12
- GBT 14039 Codes 0-24
- GJB 420B Codes, A-F: 000-12

Accuracy:

± 1/2 class for:
 ISO 4406 and GBT 14039 Codes 8-24 and for Codes 4, 6, 14 µm(c).

NAS 1638 and AS 4059 / ISO 11218 Rev E and F, Table 1 Size Codes Class 2-12,
 AS4059 / ISO 11218 Rev E and F Table 2 and GJB 420B Size classes, A: 00-12, B: 00-12, C: 00-12, D: 2-12, E: 4-12, F: 7-12

± 1 class for larger sizes and lower size codes as mentioned above

Flow

- 20 ... 400 ml/min / .00511 US GPM

Viscosity Range

- ≤ 1000 mm²/s

Temperature Range

- Media: -25 °C ... + 80 °C / -13 °F ... +176 °F
- Ambient: -5 °C ... +80 °C / +23 °F ... +176 °F

Weight

- 5,5 kg / 12.16 lbs

Power Supply

- 9 ... 36 V DC

Max. Pressure

- 420 bar / 6091 PSI
- Note: In systems with extreme pressure peaks, please contact STAUFF

Test Duration

- Settable between 10 ... 3600 sec., set ex-works to 120 sec.
- As standard with start delay and freely programmable test intervals

Moisture Sensor / Temperature Sensor

- % RH (relative humidity) ±3 %
- ±3 °C / ±32 °F

Volumetric Flow Measurement

- As display only

Hose Connections

- Test coupling STAUFF Test 20 or comparable (M16 x 2)

Data Storage

- Max. 4000 measuring results

Interfaces

- RS485, RS232, Modbus, CAN Bus

Current Consumption

- 12 V: 70 mA
- 24 V: 40 mA
- 36 V: 30 mA

Power

- <2,2 W

Housing Surface Treatment

- Polyester vinyl paint (light grey)
- Cast
- Stainless Steel
- Material spec.: ANC ABF/C

ATEX Directive 94/9/EG

Harmonises legal provisions of memberstates for devices and protection systems for designated use in potentially explosive areas.

ATEX Classification

- CE Ⓜ II 3G Ex nR IIB T6 X

ATEX Rating

- Zone 2 / Cat. 3G



Oil Sampling Kit ▪ Type KIT-SFS



Product Description

Fluid analysis is a crucial component of any oil management program. Early detection of potential problems can prevent costly repairs and downtime. STAUFF KIT-SFS oil analysis kits provide the tools to take a sample from a STAUFF test coupling or directly from a reservoir or sump.

For this the supplied hose is directly connected to the test coupling with an adaptor and the fluid is filled into the supplied vials.

But there is also the possibility to draw up the sample directly from a tank with the hand pump and fill it into the vial.

This sample set is available in two versions with BSP and NPT test couplings.

Scope of Delivery

- Contains vacuum pump for drawing samples of oil equipment
- 1 m / 3.28 ft hose for insertion into tank
- Two sample bottles
- STAUFF test points and adaptor allows oil sample to be taken from STAUFF Test 20 test points

Components

KIT-SFS-01

- 1x Fluid Sample Pump FSP-38
- 1x Hose adaptor SHA-20-5.5mm
- 1 m / 3.28 ft Push on 1/4" hose
- 1x SMK-20-1/4NPT-V-D-W3
- 1x SMK-20-7/16UNF-V-E-W3
- Sample bottles

KIT-SFS-02

- 1x Fluid Sample Pump FSP-38
- 1x Hose adaptor SHA-20-5.5mm
- 1 m / 3.28 ft Push on 1/4" hose
- 1x SMK-20-G1/4-B-C-W3
- 1x SMK-20-M10x1-B-A-W3
- Sample bottles

Order Codes

KIT-SFS		-	01		-	110		-	MC-38AL	
①			②			③			④	
① Series and Type		Oil Sampling Kit		KIT-SFS		③ Bottle Size		110 ml		110
② Version		NPT-Version		01		④ Equipment		Protoc. Container / 38 mm Aluminum pump		MC-38AL
		BSP-Version		02						

Product-Specific Abbreviations

Abbreviation	Product Category	Product Description	Page
Bottle-Sampler-LasPaC-II	Oil Analysis Equipment	Bottle Sampler Unit	76
DAV-LPM-II	Oil Analysis Equipment	Flow Control Valve	80
DISPLAY-LPM-II-plus-REMOTE	Oil Analysis Equipment	Particle Monitor	79
Flow-meter-PPC-04/12-SFM	Hydraulic Testers	Flow Turbine	42
Flow-meter-PPC-CAN-SFM	Hydraulic Testers	Flow Turbine	43
Interface-LPM-II-USB/ETH	Oil Analysis Equipment	Particle Monitor Interface	79
KIT-SFS	Oil Analysis Equipment	Oil Sampling Kit	82
LasPaC-II-M	Oil Analysis Equipment	Laser Particle Counter (Mobile)	74
LasPaC-3-P	Oil Analysis Equipment	Laser Particle Counter (Professional)	70
LPM-II- ... -CX/2	Oil Analysis Equipment	Particle Monitor (ATEX)	81
LPM-II-plus	Oil Analysis Equipment	Particle Monitor	78
PPC-04-plus-SET	Hydraulic Testers	Complete Systems	48
PPC-PAD-light-SET	Hydraulic Testers	Complete Systems	48
PPC-04-plus-CAN-SET	Hydraulic Testers	Complete Systems	49
PPC-PAD-light-CAN-X-SET	Hydraulic Testers	Complete Systems	49
PPC-04-plus	Hydraulic Testers	Hydraulic Testers	26
PPC-04-plus-CAN	Hydraulic Testers	Hydraulic Testers	26
PPC-PAD-light	Hydraulic Testers	Hydraulic Testers	29
PPC-PAD-light-CAN	Hydraulic Testers	Hydraulic Testers	29
PPC-PAD-light-CAN-AUX	Hydraulic Testers	Hydraulic Testers	29
PPC-PAD-plus	Hydraulic Testers	Hydraulic Testers	33
PPC-PAD-plus (Starter System)	Hydraulic Testers	Complete Systems	50
PT-RF	Hydraulic Testers	Pressure Transmitter	54
PT-RF-SET	Hydraulic Testers	Pressure Transmitter (Complete Systems)	56
Reader-PT-RF	Hydraulic Testers	Pressure Transmitter Reader	55
SBAA	Hydraulic Testers	Accumulator Adaptor for Pressure Transmitter	58
SBAA-P	Hydraulic Testers	Accumulator Adaptor for Pressure Transmitter	59
SDAA	Hydraulic Testers	Accumulator Adaptor for Pressure Transmitter	58
SDM	Hydraulic Testers	Flow Indicators	62
SDMKR	Hydraulic Testers	Flow Indicators	62
Sensorconverter-PPC	Hydraulic Testers	Current / Voltage / Frequency Converter	45
Sensor-PPC-04/12-P	Hydraulic Testers	Pressure Sensors	36
Sensor-PPC-04/12-PT	Hydraulic Testers	Pressure / Temperature Sensors	40
Sensor-PPC-04/12-SDS-CAB	Hydraulic Testers	Rotational Speed Sensor	44
Sensor-PPC-04/12-T	Hydraulic Testers	Temperature Sensors	38
Sensor-PPC-CAN-P	Hydraulic Testers	Pressure Sensors	37
Sensor-PPC-CAN-PT	Hydraulic Testers	Pressure / Temperature Sensors	41
Sensor-PPC-CAN-T	Hydraulic Testers	Temperature Sensors	39
SMB-20 / SMB-15	Pressure Gauges	Analogue Pressure Test Kit	18
SMB-DIGI / SMB-DIGI-USB	Pressure Gauges	Digital Pressure Test Kit	21
SPG	Pressure Gauges	Analogue Pressure Gauge	16
SPG-DIGI / SPG-DIGI-USB	Pressure Gauges	Digital Pressure Gauge	20

