



STAUFF Filtration Technology

Filter housings and replacement filter elements
for hydraulics

Product Catalogue

Version
10/2025

Germany

Walter Stauffenberg GmbH & Co. KG

Im Ehrenfeld 4
58791 Werdohl

www.stauff.com

STAUFF products and services are globally available through wholly-owned subsidiaries and a tight network of authorised distributors and representatives in all major industrial regions of the world.

You can find detailed contact information on the last two pages of this product catalogue or at www.stauff.com/contact.

Please note: Unless otherwise stated, all data and figures in this product catalogue are approximate values and are only valid as references, which are not binding (also in respect to any third parties' rights of protection) and thus do not release the customer / user from checking and testing the suitability of the products for the foreseen purposes. Therefore, data and figures can only be used in a limited sense for construction purposes.

The application of the products is beyond the control possibilities of the manufacturer and, therefore, is exclusively subject to the responsibility of the customer / user.

In the event that a liability is nevertheless considered, any compensation will be limited to the value of the goods supplied by the manufacturer and used by the customer / user. As a matter of course, the manufacturer guarantees the perfect quality of all products in accordance with the General Terms and Conditions of Business and Sale.

Subject to modifications due to the ongoing development and improvement of the products.

With the publication of this product catalogue, previous editions are no longer valid.

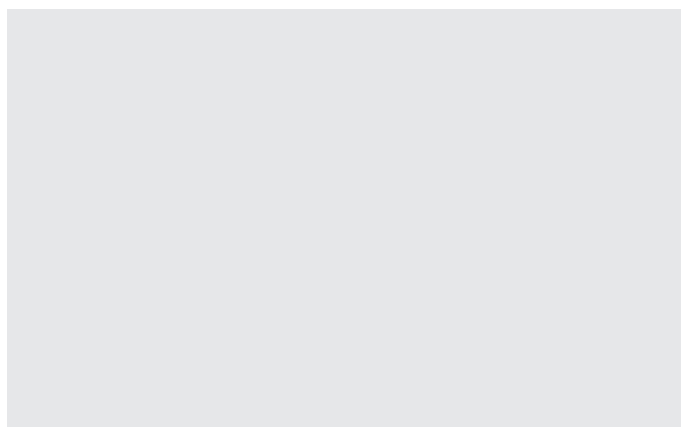
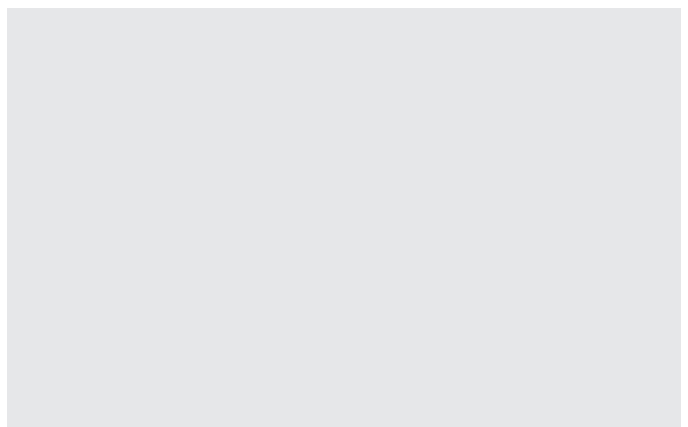

Introduction	4 - 11	
Filtration Guideline	12 - 23	A
Replacement Filter Elements	24 - 33	B
Pressure Filters	34 - 65	C
Return-Line Filters	66 - 125	D
In-Line Filters	126 - 147	E
Spin-On Filters	148 - 177	F
Offline and Bypass Filters	178 - 205	G
Filtration Systems	206 - 209	H
Appendix (Product-Specific Abbreviations)	211 - 213	



Catalogue 1
STAUFF Clamps

- Block Clamps
- Special Clamps
- Light Series Clamps
- Saddle Clamps
- U-Bolt Clamps
- Metal Clamps
- Construction Series



Catalogue 2
STAUFF Connect

- Tube Connectors
- Assembly Tools and Devices



Catalogue 3
STAUFF Flanges

- SAE Flanges
- Gear Pump Flanges



Catalogue 4
STAUFF Hose Connectors

- Hose Connectors
- High-Pressure Hose Connectors



Catalogue 5
STAUFF Quick Release Couplings

- Push-to-Connect Couplings
- Multi Couplings
- Screw-to-Connect Couplings

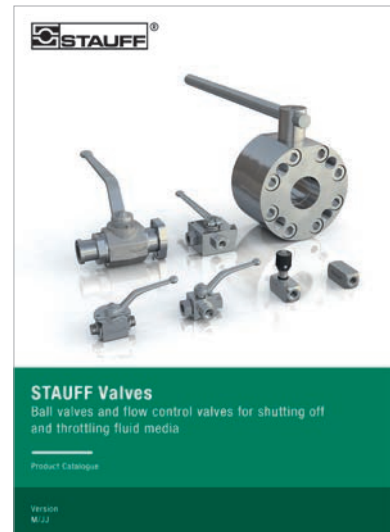

Catalogue 6
STAUFF Valves

- Two-Way Ball Valves
- Multi-Way Ball Valves
- Flow Control and Check Valves
- Gauge Isolator Valves



Catalogue 7
STAUFF Test

- Test Couplings
- Test Adaptors
- Test Hoses and Connectors



Catalogue 8
STAUFF Diagtronics

- Pressure Gauges
- Hydraulic Testers
- Oil Analysis Equipment



Catalogue 9
STAUFF Filtration Technology

- Replacement Filter Elements
- Pressure Filters
- Return-Line Filters
- In-Line Filters
- Spin-On Filters
- Offline and Bypass Filters
- Filtration Systems



Catalogue 10
STAUFF Hydraulic Accessories

- Fluid Level and Temperature Indicators
- Tank Filler Breathers
- Giant and Desiccant Air Breathers
- Suction Strainers
- Diffusors

For more than 50 years, the companies of STAUFF Group have been developing, manufacturing and distributing pipework equipment and hydraulic components for mechanical and plant engineering and for service and industrial maintenance.

In addition to mobile and industrial hydraulic machinery, typical applications also include commercial and special purpose vehicles, rail transportation and energy technology. Likewise, STAUFF products are used in marine, oil and gas applications and in the process, food and chemical industries.

The overall range currently includes about 50000 standard products as well as numerous special and system solutions according to customer's specifications or based on our in-house development.

All STAUFF products undergo relevant testing in accordance with international regulations and are governed by the high standards of the in-house quality management system. Furthermore, many items have received certifications and approvals from various international institutes, organisations and authorities who have independently confirmed the quality and performance of the products.

Wholly-owned manufacturing, sales and service facilities in 18 countries and a tight global network of authorised distribution partners ensure high presence and service paired with a maximum of availability.



Quality Management – ISO 9001:2015
Environmental Management – ISO 14001:2015
Safety Management – ISO 45001:2018
Energy Management – ISO 50001:2018

STAUFF LINE Components

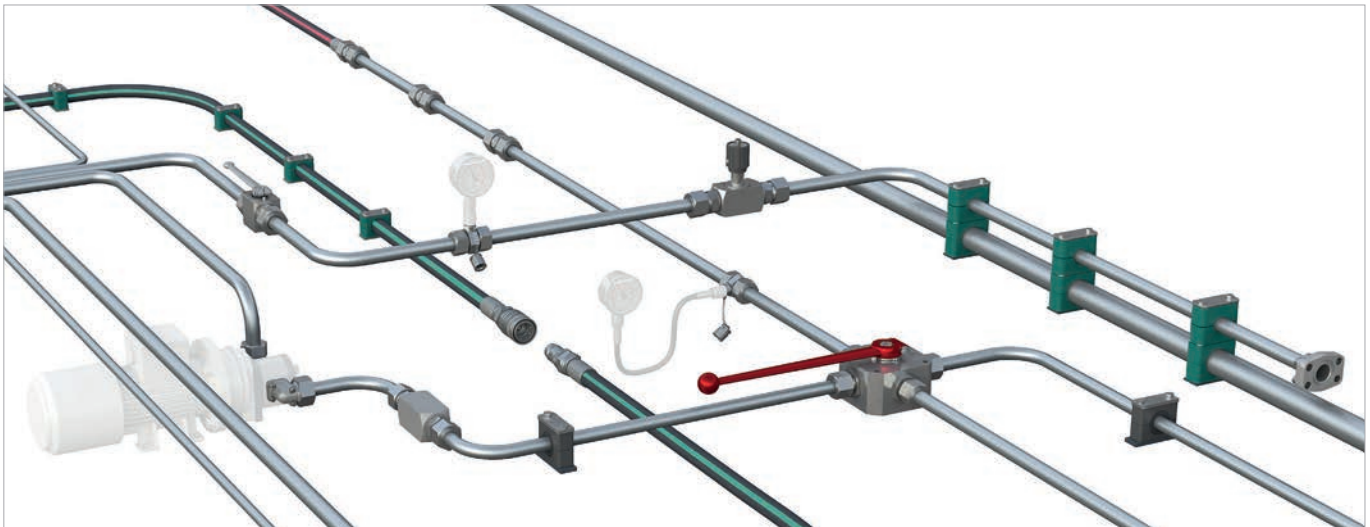

With the seven dedicated **STAUFF Line** product groups

- **STAUFF Clamps**
- **STAUFF Connect**
- **STAUFF Flanges**
- **STAUFF Hose Connectors**
- **STAUFF Quick Release Couplings**
- **STAUFF Valves**
- **STAUFF Test**

from own, in-house development and manufacturing, the companies of the STAUFF Group provide a comprehensive range of components for fastening and connecting pipes, tubes and hoses for mobile and industrial hydraulic applications and many other industries.

The portfolio is completed by components for shutting-off, regulating, throttling and measuring fluid media.

In order to perfectly match each other, STAUFF Line products are designed and offered on a high, uniform level of quality. A large proportion of the range made from steel comes as standard with the premium STAUFF Zinc/Nickel surface coating, which is also optionally available for many of the other components.

This coating offers the most reliable surface protection far beyond the previous market standards – even after transport, handling and assembly of the components – and meets all current legal requirements.

If desired, Original Equipment Manufacturers can be supported with value-added services, from **technical consultation to pre-assembly, assembly and kitting** as well as **logistics services**:

- Support with the **selection of suitable standard components** and ordering options; provision of **customised solutions** according to customer's specifications or based on our in-house development – from prototyping to large scale production
- **Analysis and optimization** of existing and design and developments of new systems aimed at increasing the efficiency and performance of machines and equipment and creating value for customers by reducing the total cost
- **Pre-assembly, assembly and kitting** of individual components to customer-specific system modules
- Individually coordinated **procurement solutions** (e.g. web shop and electronic data interchange) and **supply models** (e.g. from warehousing of customised components to Kanban logistics and just-in-time delivery of pre-fabricated system modules to the assembly lines of the customers) aimed at optimising material flows

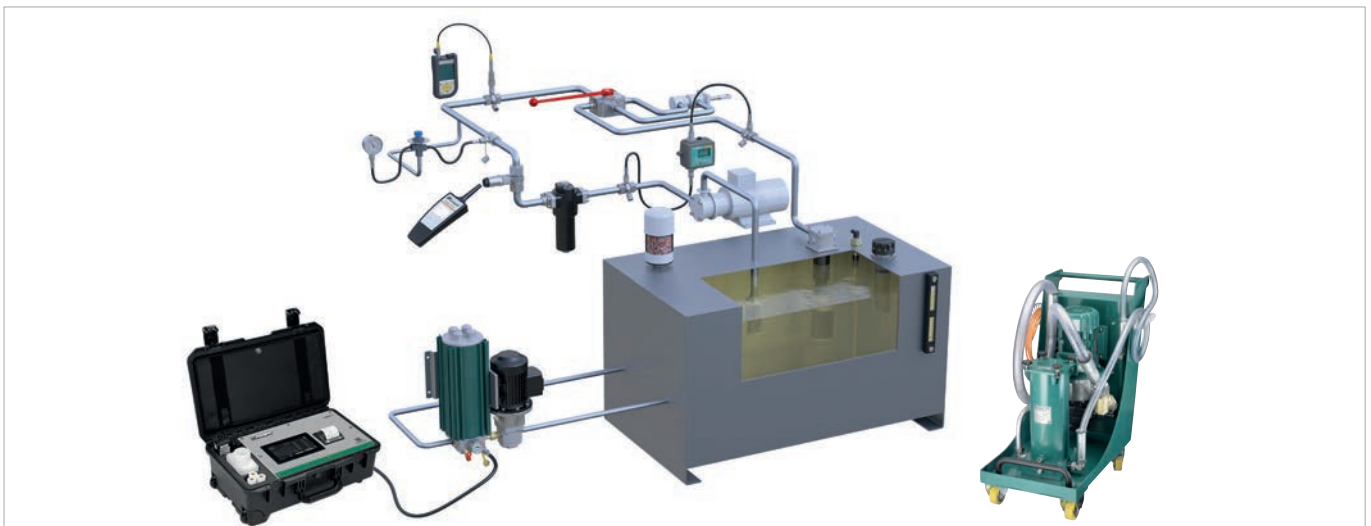

Aligned with the needs of the market, the product groups

- **STAUFF Test**
- **STAUFF Diagtronics**
- **STAUFF Filtration Technology**
- **STAUFF Hydraulic Accessories**

include a comprehensive range of analogue and digital measuring equipment and devices, filtration systems and replacement filter elements as well as accessories for the construction of tanks, reservoirs, power packs and gear boxes in mobile and industrial hydraulics.

The offer is completed by relevant value-added services:

- Support with the **selection of suitable components** and ordering options; provision of **customised solutions** according to customer's specifications or based on our in-house development – from prototyping to large scale production
- Analysis of existing hydraulic circuits aimed at filtration systems, tank components and monitoring devices that perfectly match to the specific requirements, and developing integrated concepts to increase the efficiency and performance of machines and equipment
- Individually coordinated **procurement solutions** and **supply models**



STAUFF Filtration Technology

The STAUFF Filtration Technology product range contains an extensive product range in the areas of filtration and purification of oils and other media, which fully meets – or even exceeds – the requirements of modern service and maintenance of machines and equipment.

As an experienced manufacturer, STAUFF provides quick and direct access to a complete range of replacement filter elements for industrial liquids such as hydraulic and lubrication oils, heavy fuels, water, chemicals, coolants and other media – equal in form, fit and function to the original products while maintaining or surpassing their performance.

Flexible manufacturing lines and extensive stock-keeping in the country of destination guarantee fast reaction times and shortest delivery times.

STAUFF guarantees prompt service, even for customised solutions according to customer's specifications or based on our in-house development.

STAUFF filter housings and systems can be installed in the pressure, suction or return line. They are already planned in suitable positions in the hydraulic circuit during the design phase of a machine, or added at a later stage in the course of retrofitting or upgrading.

Offline and bypass filters, which are either used as portable units or installed permanently, complete the product portfolio.

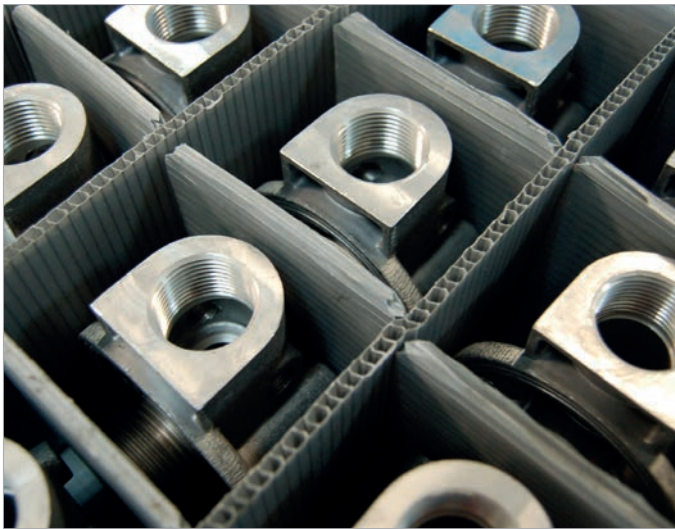



www.stauff.com

With the STAUFF Digital Platform available at www.stauff.com, commercial customers and users of STAUFF products can not only inform themselves in all detail about the 50000 components typically available from stock, but also directly purchase these online without complex registration.

General information about the companies of STAUFF Group, latest business and product news as well as complete global contact details also be available.



www.stauff.com/cad

Immediate access to and free download of 3D models and 2D drawings for a growing number of STAUFF products





www.filterinterchange.com

Online database for the quick and easy identification and interchange of almost all common brands and types of replacement filter elements

Main Functionalities of the STAUFF Digital Platform:

-  **Around the clock**
Check stock availability and pricing for STAUFF products in real time
-  **Cross references**
Search by article designations of other manufacturers / suppliers
-  **Live chat**
Get directly in touch with the STAUFF customer service and sales team
-  **CAD database**
Download 3D models and 2D drawings for STAUFF products

Advantages as a Registered User of the STAUFF Digital Platform:

-  **Purchase STAUFF products**
Taking customer-specific pricing and delivery conditions into account
-  **Ordering w/o searching**
Quick ordering by entering article number, quantity and requested delivery date
-  **File upload**
Direct upload of orders with multiple positions in CSV or Excel file format
-  **Notepad function**
Create project lists to save interesting products for later

Follow STAUFF and keep yourself updated:

 **LinkedIn**
www.linkedin.com/company/stauff

 **Youtube**
www.youtube.com/stauffgroup

 **STAUFF Newsletters**
Automatic e-mail notifications about latest news from STAUFF
www.stauff.com/newsletter

Filtration Guideline	12 - 23
Filtration - Why?	15
Contamination	15
STAUFF Filter Components	16 - 17
Test Standards and Oil Purity	18
Short & Curt: Filter Rating	19
β -Value and Separations Efficiency	19
Filtration Terminology	20 - 21
Choice of Filters / Examples of Calculation	22 - 23



Filtration - Why?

Good hydraulic filtration is gaining more and more importance in the use of hydraulic systems.

Reducing contamination in the hydraulic system will reduce the wear of the components and thus extend the service life of the machine. This will prevent production downtime and lower the overall production costs.

Right from the beginning, there is contamination in a new hydraulic system, which reduces the service life of the system and its components such as valves and cylinders without any or with inadequate filtration.

This built-in dirt is created during the manufacturing of the components and mainly consists of coarse particles.

In addition to the contamination that arises during operation of the system, e.g. abrasive wear, dirt particles can also get into the system when it is filled with hydraulic oil. This is called ingress contamination.

Choosing the right filter contributes significantly to prevent the dangers mentioned above thereby ensuring efficient operation even after many years.

Reduction of Contamination

- Extension of service life
- Extension of maintenance intervals
- Reduction of machine downtime
- Reduction of environmental pollution

► Cost savings for the user

Contamination

Particle Sizes (Selection)

- 100 µm table salt, fine sand
- 75 µm diameter of a human hair
- 60 µm flower pollen
- 50 µm fog
- **30 µm (from approx.) resolution of the human eye**
- 15 µm fine particles
- 7 µm red blood cells
- 2 µm bacteria
- 1 µm layer of lubricating film (for comparison)

Type of Contamination

The most frequent ones are:

- Solid particles
- Free and dissolved water
- Non-dissolved air

A majority of the contamination can be removed with filtration.

Origin of Contamination

The main cause of failures and downtimes is dirt in the hydraulic system.

Failure analysis indicate that 80% of the failures are caused by faults in the hydraulic system. 90% of them are caused by impurities in the hydraulic oil.

Sources of External Contamination

- Filling and refilling the hydraulic tank
- Inadequately dimensioned breathers
- Damaged tank seals
- Replacement of hydraulic lines and components (pumps, cylinders)
- Impurities in the air

Types of Internal Contamination

- Contamination on / in the components caused by the manufacturing process (e.g. chips)
- Contamination on the components caused by the installation of the components

Sources of Internal Contamination

- Disintegration of particles from high pressure changes and tension on the surface of hydraulic components (e.g. cavitation)
- Material erosion that occurs at places in the hydraulic units due to the impact of pressurised liquid at high speeds (erosion wear)

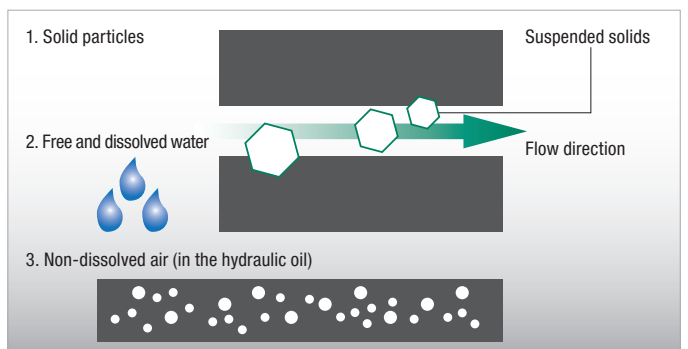
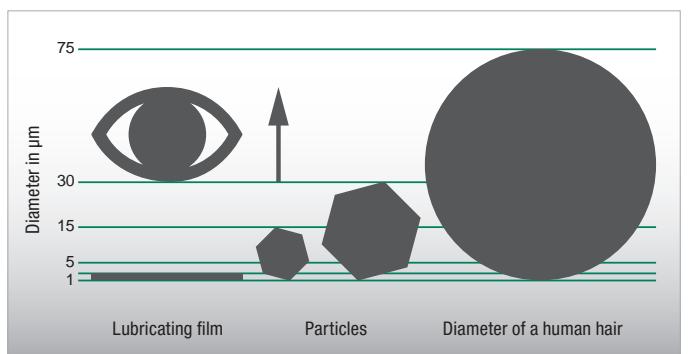

A



STAUFF Laser Particle Counter LasPaC-II-M and Bottle Sampler

Selection of Components within the Hydraulic Circuit

- ① STAUFF Mobile Filter System **SMFS-U**
- ② STAUFF Plastic Filler Breather **SPB**
- ③ STAUFF Return-Line Filter **RF**
- ④ STAUFF Diffusor **SRV**
- ⑤ STAUFF Suction Strainer **SUS**
- ⑥ STAUFF Pressure Filter **SF**
- ⑦ STAUFF Desiccant Air Breather **SDB**
- ⑧ STAUFF Offline Filter **OLS**
- ⑨ STAUFF Level Gauge **SNA**
- ⑩ STAUFF Spin-On Filter **SSF**
- ⑪ Oil tank
- ⑫ STAUFF Reader **PT-RF**
- ⑬ STAUFF Pressure Transmitter **PT-RF**
- ⑭ STAUFF Hydraulic Tester **PPC**
- ⑮ STAUFF Particle Monitor **LPM-II**
- ⑯ STAUFF Particle Counter **LasPaC-3**
- ⑰ STAUFF Pressure Gauge **SPG**
- ⑱ STAUFF Test Coupling **SMK / SKK**

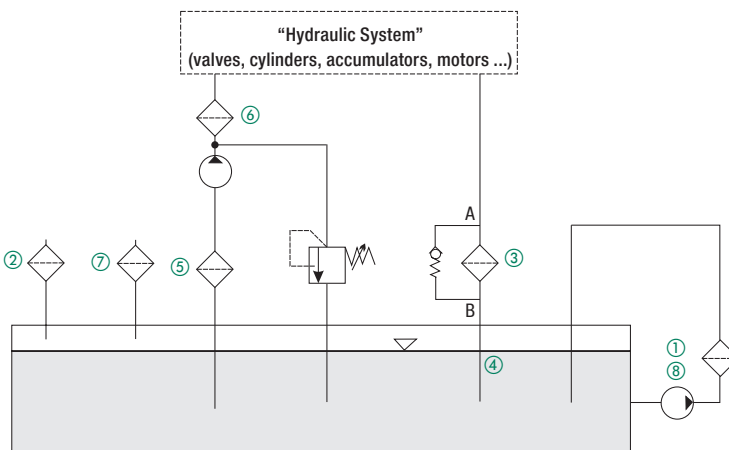
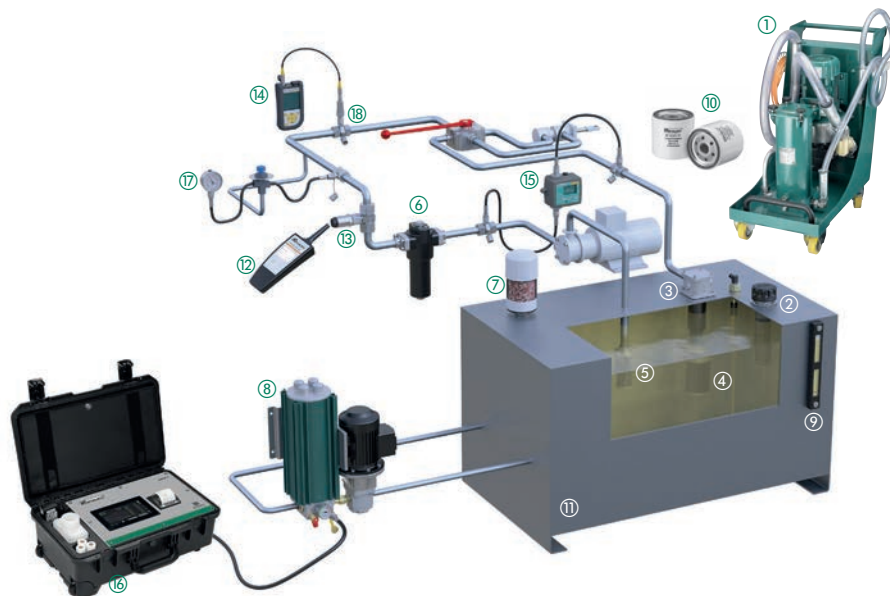

STAUFF Filter Components

A



Pressure Filters Series SF / SF-TM / SFZ / SFA / SMPF (see page 34 - 35)

Pressure Filters ⑥ are placed behind the pump and clean the hydraulic oil before it flows through down-stream components like valves, cylinders and so on. The main reason for pressure filtration is the protection of downstream, sensitive components.

Eroded particles from the pump are immediately filtered out of the hydraulic oil. Besides working as a protection filter, Pressure Filters also help to maintain the required purity class.

Because it is placed right behind the pump, a Pressure Filter has to withstand the maximum system pressure. The filter element in the Pressure Filter also has to withstand the loads and is more intricately constructed, for example as a Return-Line Filters element.



Return-Line Filters Series RF / RFA / RFB / RFS / RTF (see page 66 - 125)

Return-Line Filters ③ are installed in the Return-Line, on top of or within the oil tank. They filter the hydraulic oil before it flows back into the reservoir. This ensures that contamination arising in the components does not get into the tank. Return-Line Filters maintain the targeted purity class like Pressure Filters. However, because of their arrangement, they do not fulfil the additional function of a protection filter. In contrast to a Pressure Filter, it only has to withstand low pressure levels.

Diffusers ④ are used in combination with Return-Line Filters and ensure that the returning oil flow is settled before it reaches the oil tank thereby preventing foaming and re-suspension of deposited dirt.

The job of **Suction Strainers** ⑤ is mainly to provide functional protection of the downstream pumps in the circulation. Suction Strainers always have to be provided if the risk of pump damage from coarse impurities is particularly high. This risk exists if impurities are collected in the tank and if they can't be filtered out afterwards. Suction Strainers are coarse filter elements with a micron rating that is usually bigger than 100 µm.



Diffusers / Suction Strainers / Filler Breathers / Desiccant Air Breathers (see Catalogue No. 10 - Hydraulic Accessories)

Filler Breathers ② are mounted on the oil tank and prevent the entry of dirt from the surroundings during tank breathing. They should be chosen with a filter unit that is similar to the working filter (Pressure Filter, Return-Line Filter).

The replacement cycles of filter inserts is highly dependent on the surrounding conditions of the hydraulic system.

Another variant of the breather is the **Desiccant Air Breather** ⑦. The additional function of this filter is dehumidification of the inflowing air with a special silicate gel.



Offline and Bypass Filters / Mobile Filter Units (see page 178 - 209)

Offline / Bypass Filters ⑧ / ① are not part of the main hydraulic system. They are supplementary to achieve the best possible filtration results. Because of the high efficiency of the Offline / Bypass Filters, purity levels are reached that cannot be achieved with conventional main filter systems.

Offline Filters work with an integrated motor / pump unit that draws in the fluid from the system, filters it and then feeds it back into the tank. Because the offline filter is independent from the hydraulic main circuit, i.e. it can still be operated if the hydraulic system is switched off, it is used in practice for continuous cleaning of the tank.

Bypass Filters on the other hand use the existing system pressure to draw a small volumetric flow out of the hydraulic system for filtration. They are only active while the unit is in operation.

Another mobile variant of the bypass filter is the **Mobile Filter System** ①.



Spin-On Filters (see page 148 - 177)

STAUFF provides a complete range of **Spin-On Filters** ⑩ which can be used either as Suction Filters or as Return-Line filters for low pressure applications.

A

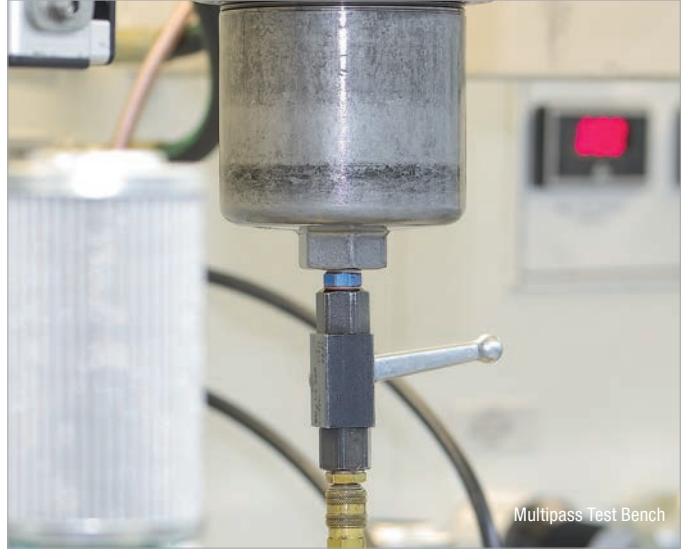
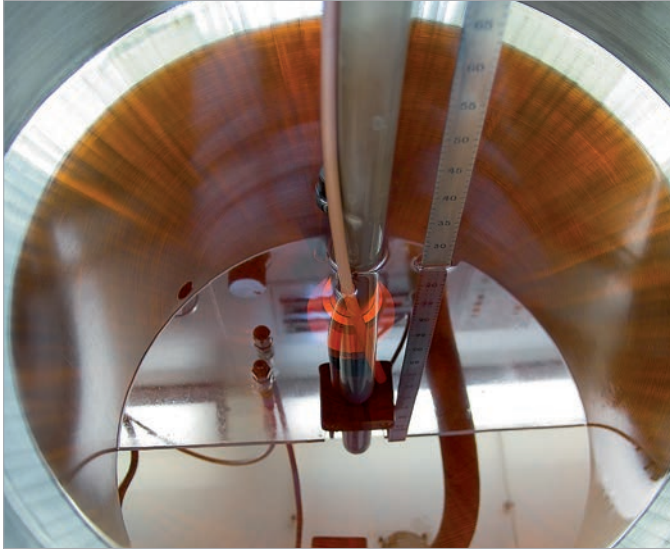

Multipass Test Bench

Test Standards and Oil Purity

Definition of the Required Micron Rating

Essentially, the components found in the hydraulic system determine the micron rating of the filtration system.

To guarantee a reliable mode of operation over the years, it is mandatory to maintain the optimum oil purity class for specific components.

The most sensitive component determines the choice of filter material and micron rating.

To determine the oil purity according to ISO 4406 (1999), a laser particle counter is used to count particles that are $>4 \mu\text{m}_{(c)}$, $>6 \mu\text{m}_{(c)}$ and $>14 \mu\text{m}_{(c)}$ in 100 ml of hydraulic oil. The number of particles is then assigned with a classification number (e.g. 14/11/8) that then corresponds to the ISO purity class. Please note here that the number of particles doubles for the next higher class. The cleanliness level that has to be achieved is an important criterion for choosing the right filtration system.

STAUFF Filter Elements are subject to the following Test Methods

- ISO 2941 Collapse and burst resistance
- ISO 2942 Verification of fabrication integrity (bubble point test)
- ISO 2943 Compatibility with hydraulic media
- ISO 3723 End load test
- ISO 3724 Flow fatigue characteristics
- ISO 3968 Flow characteristics
- ISO 16889 Filtration performance test (multi-pass method)

Number of particles in 100 ml fluid		Classification numbers ISO 4406 (1999)		
More than	Less than	$> 4 \mu\text{m}_{(c)}$	$> 6 \mu\text{m}_{(c)}$	$> 14 \mu\text{m}_{(c)}$
16000000	32000000	25	25	25
8000000	16000000	24	24	24
4000000	8000000	23	23	23
2000000	4000000	22	22	22
1000000	2000000	21	21	21
500000	1000000	20	20	20
250000	500000	19	19	19
130000	250000	18	18	18
64000	130000	17	17	17
32000	64000	16	16	16
16000	32000	15	15	15
8000	16000	14	14	14
4000	8000	13	13	13
2000	4000	12	12	12
1000	2000	11	11	11
500	1000	10	10	10
250	500	9	9	9
130	250	8	8	8
64	130	7	7	7
32	64	6	6	6
16	32	5	5	5

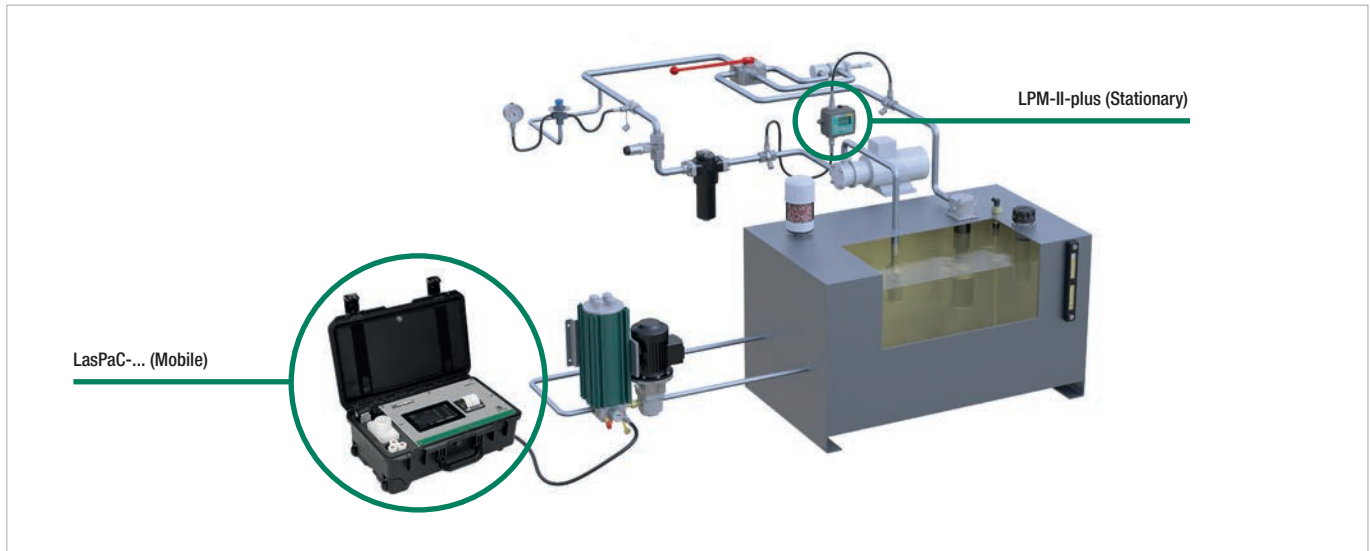

Short & Curt: Filter Rating

(For exact recommendation see SCCP - STAUFF Contamination Control Program see on page 15)

Type	Component	ISO 4406 Code	Recommended Filter Rating
Pump	Piston Pump (Slow Speed, Inline)	22/20/16	20 µm
	Gear Pump	19/17/15	20 µm
	Vane Pump	18/16/14	5 µm
	Piston Pump (High Speed, Variable)	17/15/13	5 µm
Motor	Gear Motor	20/18/15	20 µm
	Vane Motor	19/17/14	10 µm
	Radial Piston Motor	19/17/13	10 µm
	Axial Piston Motor	18/16/13	5 µm
Valve	Directional Valves (Solenoid)	20/18/15	20 µm
	Check Valves	20/18/15	20 µm
	Logic Valves	20/18/15	20 µm
	Cartridge Valves	20/18/15	20 µm
	Pressure Control Valves (Modulating)	19/17/14	10 µm
	Flow Control Valves	19/17/14	10 µm
	Standard Hydraulic <100 bar / <1450 PSI	19/17/14	10 µm
	Proportional Valves	18/16/13	5 µm
	Servo Valves <210 bar / <3045 PSI	16/14/11	3 µm
	Servo Valves >210 bar / >3045 PSI	15/13/10	3 µm
Actuator	Cylinder	20/18/15	20 µm

β-Value and Separations Efficiency

To select filtration that meet the requirements, performance characteristics like the filter fineness, the filtration efficiency, the dirt-hold capacity and the pressure loss has to be observed.

The β-value as per ISO 16889 is the relevant characteristic value for the filtration efficiency. The β-value is the ratio of particles before ($N_{up\ x}$) and after ($N_{down\ x}$) the filter related to a specific particle size x.

$$\beta_x = \frac{N_{up\ x}}{N_{down\ x}}$$

$\beta_{10} > 200$ means that of 1000 particles that are 10 µm in size, only five particles can pass through the filter. 995 particles will be trapped by the filter element.

Popular filters with inorganic glass fibre medium have to achieve a β-value of at least 200 in order to meet the demands placed on hydraulic filtration today.

The filtration efficiency, also called the retention rate, is directly related to the β-value and is calculated as follows:

$$E = \frac{(\beta_x - 1)}{\beta_x}$$

$\beta_{10} > 200$ corresponds to filtration efficiency of 99,5%.

Comparison of the β-Value and Efficiency E (each related to a defined Particle Size)

β-value	Filtration Efficiency E
1	0,00 %
2	50,00 %
10	90,00 %
25	96,00 %
50	98,00 %
75	98,67 %
100	99,00 %
200	99,50 %
1000	99,90 %
9999	99,99 %

The **dirt-hold capacity** (DHC) shows how much solid dirt a filter element can hold before it has to be replaced. The dirt-hold capacity is therefore the most important parameter in the filter service life.

The **differential pressure** (Δp) is another important criterion for the configuration of the filter. Ensure that the size of the filter element is chosen according to the calculation guideline by STAUFF.

To guarantee optimum filtration, the β-value, the dirt-hold capacity (DHC) and the differential pressure (Δp) must be carefully matched.

Filtration Terminology

β-value

The β-value as per ISO 16889 is the relevant characteristic value for filtration efficiency. The β-value is the ratio of particles before ($N_{up\ x}$) and after ($N_{down\ x}$) the filter related to a specific particle size x.

$$\beta_x = \frac{N_{up\ x}}{N_{down\ x}} \quad (\text{see page 19})$$

Cavitation Damage

Cavitation is defined to be the cavity formation in liquids. Cavitation occurs if the local static pressure of a liquid drops below a critical value. This critical value usually corresponds to the vapour pressure of the liquid. Critical effects of cavitation are:

- Cavitation wear
- Undissolved gas in the hydraulic system
- Loud high-frequency noises
- Local high temperatures in the liquid
- Changes to the resistance characteristics of the hydraulic resistance

Cleanliness Level

The cleanliness level of a hydraulic fluid is defined by the number of solid particles per ml of fluid. The number of particles is usually measured with an automatic particle counter. The cleanliness level is determined by a class code created by counting the number of particles of different sizes.

Particle counting as well as the coding of the cleanliness class for hydraulic oils are described in the ISO 4406 (1999) standard. Beside the ISO 4406 (1999), NAS 1638 (1964) and SAE AS4059 Rev. D (2001) are also still common.

Clogging Indicator

The clogging indicator signals a specific pressure level where the soiled filter element should be replaced. They work with differential pressure (Δp) or back pressure. Clogging indicators are available in visual, electrical and visual / electrical versions. While it is the responsibility of the installation or maintenance personnel to check the degree of clogging of the filter element with visual clogging indicators, a signal contact (switch) can be connected to the machine controller with an electrical or visual / electrical clogging indicator.

Collapse Pressure

The permissible collapse pressure according to ISO 2941 is understood to be the pressure difference that a filter element can withstand with the stipulated direction of flow. Exceeding the collapse pressure results in the destruction of the filter element.

Depth Filter

Impurities penetrate into the filter fabric and are retained by the structure of the filter fabric. Mainly cellulose and inorganic glass fibre media are used in hydraulic filters. For special applications, Plastic Media (high-strength) and Stainless Fibre media are also used. The design of the depth filter combines the highest micron rating with a high dirt retention capacity. Due to the fleece-like structure of depth filters, particles are not only separated on the surface of the filter material, but they can penetrate into the filter material, which leads to a considerable increase of the effective filter area. In contrast to sieves, there are no holes in fleece, rather they practically consist of labyrinths in which the particles are trapped. Hence, there is no sharply defined screening, rather a wide range of particles are trapped.

Differential Pressure

The differential pressure (Δp) is defined as the pressure difference between the filter inlet and the filter outlet, or alternatively in front of and behind the filter element.

Exceeding the maximum permissible pressure differential leads to the destruction of the filter element.

An integrated bypass valve in the filter prevents destruction of the filter element by opening if the differential pressure (Δp) is too high. Then the oil is passed unfiltered into the hydraulic circuit. For applications in which no unfiltered oil is allowed to pass into the hydraulic circuit, there is the possibility of using filters without bypass valves with filter elements that can withstand a high differential pressure (Δp). The filter elements must be designed such that they can withstand the maximum expected differential pressure (Δp).

Dirt-Hold Capacity (DHC)

The dirt-hold capacity (DHC) shows how much solid dirt a filter element can hold. It is measured in the multipass test according to ISO 16889.

Filter

A filter (hydraulic filter) has the job of keeping solids out of a liquid (oil). A filter is usually made of an filter housing and a filter element.

Filter Area

The filter area is the size of the theoretically spread-out filter element. The larger the filter area, the lower the flow resistance of the filter element. Simultaneously, the dirt-hold capacity (DHC) increases. The following applies in general: the larger the filter area, the longer the service life of the element. Basically the filter area can be enlarged by the number of pleats.

Filter Cake

A filter cake is made up of the particles trapped on the surface of a filter medium.

Filter Design

Essentially depends on the following factors: specific flow rate, cleanliness level, amount of contamination, the maximum pressure setting and the required filter service life.

Filter Element

The filter element is located in the filter housing and performs the actual filtering task.

Filtration Efficiency

Filtration efficiency E is a measure of the effectiveness of a filter element for separating solid particles. It is given in percent.

Filter Housing

Depending on the application, the filter housing is built into the pressure or Return-Line and must be designed for the specific operating or system pressure and the flow rate. The filter element is located in the filter housing. Depending on the application, the filter housing may be equipped with a bypass valve, a reversing valve, a clogging indicator and other options.

Filter Material

The choice of the right filter material is dependent on different criteria. Amongst others, this includes the type of application, the filter function, degree of contamination or alternatively the required dirt-hold capacity (DHC) as well as requirements of chemical or physical resistance. The following list gives you an overview of how these filter materials differ with regard to specific properties:

Inorganic Glass Fibre

Inorganic Glass Fibre media are among the most important materials in modern filtration. During production, selected fibres (1 mm ... 5 mm long and with a diameter of 3 μm ... 10 μm) are processed into a specific mix. The manufacturing process is very similar to paper production. The fibres are bound with a resin and impregnated. The benefit compared to cellulose paper is a fibre structure that is considerably more homogenous and consequently has larger open pored surfaces. As a result, lower flow resistance is achieved.

- Based on Glass Fibres with acrylic or epoxy resin binding
- High retention and dirt-hold capacity (DHC)
- Excellent separation efficiency of the finest particles due to the three-dimensional labyrinth structure with depth filtration
- Outstanding price / performance ratio

Filter Material (Continuation)

Polyester

- 100% Polyester Fibres with thermal bonding
- High pressure differential resistance
- Good chemical resistance
- High separation efficiency of the finest particles
- Tear-proof structure

Cellulose

- Filter material made of Cellulose Fibres with special impregnation
- Variants with the lowest price with good dirt retention capacity
- Not suitable for water based media

Stainless Fibre

- Sintered Stainless Fibres with three-dimensional labyrinth structure for depth filtration
- Low flow resistance with high dirt-hold capacity
- Excellent chemical and thermal resistance

Stainless Mesh

Filter elements with a Metal Wire Mesh are often used as a conditionally reusable solution in protection filters, Suction-Line Filters or Return-Line Filters. Depending on the requirements (micron rating, pressure, dynamics) different types of mesh are used like twill, linen, or also Dutch weave.

- Wire mesh fabric made of material 1.4301 or 1.4305 for surface filtration (other material on request)
- Low flow resistance due to large-pored screening surface
- Excellent chemical and thermal resistance
- Cleanable under special conditions

Flow Rate

This is the amount of fluid that flows past a specific cross-section per unit time. It is given in litres per minute (l/min) or gallons per minute (US GPM).

Hydraulic Fluid

A pressure liquid is defined to be a fluid used in hydraulic and lubrication systems. According to ISO 6743, the fluids are divided into mineral oil based, flame resistant and biodegradable liquids.

Micron Rating

Regarding micron rating, we must differentiate between the filter materials that are used. To define the micron rating for Inorganic Glass Fibre filter elements, the β -value as per ISO 16889 is commonly used.

Absolute and Nominal micron rating

Micron rating is the size of particles which are filtered out by filters at a certain efficiency. When this efficiency is at least 99.5%, we speak about absolute micron rating/filtration.

Nominal micron rating is just a commercial trick for all efficiencies lower than 99.5%, meaning that for the same micron rating (for ex. 5 μm) in the case of nominal rating, not all particles will be captured in the filter as in the case of absolute micron rating.

Multipass Test

The Multipass Test evaluates the performance of a filter element. Standardised in ISO 16889-2008, this test allows comparable and repeatable results of the elements performance. If a normal filter element life is between a few weeks up to several months, this test reduces this life down to 90 minutes. The element is subjected to a fluid that a large amount of a special test dust ISO MTD contains. Results are given for the β -ratio, dirt-hold capacity (DHC) and differential pressure. It is used for designing hydraulic circuits, developing new filter materials and comparison of different filter elements.

See also page 18 and page 19 to get more information about the outcome data. In former time this test was also known as the Multipass Test ISO 4572.

Nominal Flow Rate

The nominal flow rate describes the flow rate or the volumetric flow rate for which the respective filter has been designed. It is usually given in litres per minute (l/min) or US Gallons per minute (US GPM) and is an important parameter in the filter design.

Nominal Pressure

Pressure for which the filter is designed and which it can be identified with.

Operating Pressure / System Pressure

Maximum pressure with which the filter may be used.

Surface Filter

Impurities are separated on the surface of the filter element. Surface filters are designed to have uniform pores (gaps), therefore they can almost completely retain specific particle sizes. Surface filters are made of Metal Wire Mesh or Cellulose materials.

Other surface filters are metal-edge filters.

Valve

Bypass Valve

A bypass valve is a valve that is integrated in a filter or filter element and allows the oil to bypass the contaminated filter element if a defined pressure differential is exceeded. Bypass valves are used to protect the filter element.

Non-Return Valve

It prevents the continuation line from draining while the filter element is changed.

Reverse Flow Valve

It is used to bypass the filter element for reversible oil flow so that the fluid does not pass through the filter element in the reverse direction.

Multi-Function Valve

A combination of bypass, reverse flow and non-return valve.

Viscosity

The viscosity of a fluid describes the flow behavior of a liquid. There are the kinematic viscosity ν with the unit "m²/s" and the dynamic viscosity η with the unit "Ns/m²". In the field of filtration, in the design of filters the kinematic viscosity is required for calculating. The kinematic viscosity ν can also be calculated with the dynamic viscosity η and density ρ :

$$\nu = \frac{\eta}{\rho}$$

The kinematic viscosity unit is "mm²/s", before it was called centistokes or Stokes (1 cSt = 1 mm²/s = 10⁻⁶ m²/s). The unit of dynamic viscosity is "Ns/m²", it was previously reported in Poise (10 P = 1 Ns/m² = 1 Pa s).

Choice of Filters

Choice of a Suitable Micron Rating

Generally, the type of components incorporated in the hydraulic system will determine the micron rating required. It has been clearly demonstrated that system components will operate reliably for years if a specific minimum oil cleanliness grade is maintained. Frequently the choice will be determined by the most sensitive component in the system.

a) Operating Filter

To get a rough, first rating of what filter is needed to assure a certain oil cleanliness grade please have a look at page 19.

Apart from the specific flow rate (l/min per cm² of filter area), other factors such as operating environment and condition of seals and breathers can have an effect on the cleanliness grade which can actually be achieved.

b) Protective Filter

Occasionally, protective filters are fitted downstream of major components, e.g. the pump, to collect the debris in case of a catastrophic failure. This avoids total stripping and flushing of the system. For economic reasons, protective filters are normally one grade coarser than the operating filters since they do not significantly contribute to the cleaning of the system and this extends filter service intervals.

Choice of the Optimum Filter

In selecting the filter, the following information must be considered:

- Maximum flow volume (Q_{max}) through the filter including surge flows
- Kinematic viscosity (ν) of the fluid in mm²/s (cSt) at cold start temperature and operating temperature
- Density ρ of the fluid
- Micron rating (μ m): see table on page 19
- Filter material

The aim is to choose a filter whose total differential pressure (Δp) is not higher than $\Delta p_{max} = 1,0$ bar (for Pressure Filters) or $\Delta p_{max} = 0,5$ bar (for Return-Line filters), in a clean state at the normal operating temperature. These values have been proven in practice to give the optimum service life for the element.

The nominal flow volume of the filter is the obvious reference value for pre-selection and this should be larger than the flow to be filtered.

$$Q_{nom} > Q_{max}$$

Calculations based on the filter data will verify whether the pre-selected filter meets the requirements, at operating temperatures:

$$\begin{aligned} \Delta p_{max} &\leq 1,0 \text{ bar (for Pressure Filter)} \\ \Delta p_{max} &\leq 0,5 \text{ bar (for Return-Line Filter)} \end{aligned}$$

The total differential pressure of the assembly Δp_{Assy} is calculated by adding the differential pressure of the housing Δp_{Hous} and that of the element Δp_{Elem} . Both the kinematic viscosity and density of the operating medium should be considered for the selection, as the flow curves on the pages following have been determined with a kinematic viscosity of $\nu = 30$ cSt and a density of $\rho = 0,86$ kg/dm³. The values of the pressure drops for the Δp_{Hous} and the Δp_{Elem} can be read from the flow curves on the pages following. The values for the kinematic viscosity in cSt and the density in kg/dm³ should be inserted into the following formula:

$$\Delta p_{Assy} = \frac{\rho}{0,86} \cdot \Delta p_{Hous} + \frac{\rho}{0,86} \cdot \frac{\nu}{30} \cdot \Delta p_{Elem}$$

The filter size is suitable if the $\Delta p_{Assy} < \Delta p_{max}$. If the calculated Δp_{Assy} is higher than Δp_{max} select the next larger filter size and re-calculate until a satisfactory solution is found.

The following two examples explain and help to understand the procedure of calculating a filter.

Examples of Calculation

Example 1: Selection Pressure Filter

System Information: A Pressure Filter with an Inorganic Glass Fibre element is required immediately after the pump. The system has standard components and is operating at pressures up to 200 bar. The filter shall be fitted with a bypass valve and a visual logging indicator.

For better understanding only the calculation at the upper temperature is carried out.

Data given:	Q_{max} :	100 l/min
	Oil type:	ISO 68
	Temperature max.:	+50°C
	Viscosity $\nu_{operating}$:	44 mm ² /s
	Density ρ :	0,882 kg/dm ³
	Micron rating:	10 μ m (see table on page 19)

First Step

Pre-selection of the size: SF-045, $Q_{nominal} = 160$ l/min $> Q_{max}$

Pressure drop values (at viscosity of 30 mm²/s) from the flow characteristics:

$$\begin{aligned} \Delta p_{Hous} &= 0,15 \text{ bar} && \text{(SF-045 ... , see page 40)} \\ \Delta p_{Elem} &= 0,77 \text{ bar} && \text{(SE-045-G-10-B/4, see page 40)} \end{aligned}$$

Determination of the correction factor:

$$\Delta p_{Assy} = \frac{0,882}{0,86} \cdot 0,15 \text{ bar} + \frac{0,882}{0,86} \cdot \frac{44}{30} \cdot 0,77 \text{ bar}$$

$$\Delta p_{Assy} = 1,31 \text{ bar} \geq \Delta p_{max} = 1,0 \text{ bar}$$

Since the actual pressure drop is larger than the allowed pressure drop, a larger filter has to be chosen.

Second Step

Selection of the next larger filter size: SF-070, $Q_{nominal} = 240$ l/min $> Q_{max}$

$$\begin{aligned} \Delta p_{Hous} &= 0,15 \text{ bar} && \text{(SF-070 ... , see page 40)} \\ \Delta p_{Elem} &= 0,45 \text{ bar} && \text{(SE-070-G-10-B/4, see page 40)} \end{aligned}$$

$$\Delta p_{Assy} = \frac{0,882}{0,86} \cdot 0,15 \text{ bar} + \frac{0,882}{0,86} \cdot \frac{44}{30} \cdot 0,45 \text{ bar}$$

$$\Delta p_{Assy} = 0,83 \text{ bar} \leq \Delta p_{max} = 1,0 \text{ bar}$$

In a clean state, this filter fulfills the requirements and is suitable for the application. The correct filter designation would be **SF-070-G-10-B-T-G20-B-V**.

Example 2: Selection Return-Line Filter

System Information: A Return-Line filter with a Cellulose element with a micron rating of 10 µm is required to clean the oil. No logging indicator is required.

Please note: If the system incorporates either accumulators or cylinders, the return flow can dramatically exceed pump flow and the maximum surge flow should be the flow used to calculate the pressure drop through the filter.

Data given:	Q_{\max} :	100 l/min
	Oil type:	ISO 68
	Temperature max.:	+60°C
	Viscosity $\nu_{\text{operating}}$:	29 mm ² /s
	Density ρ :	0,882 kg/dm ³
	Micron rating:	10 µm (see table on page 19)

First Step

Pre-selection of the size: RF-030, $Q_{\text{nominal}} = 110 \text{ l/min} > Q_{\max}$

Pressure drop values (at viscosity of 30 mm²/s) from the flow characteristics:

$$\Delta p_{\text{Hous}} = 0,30 \text{ bar} \quad (\text{RF-030 ... , see page 72})$$

$$\Delta p_{\text{Elem}} = 0,067 \text{ bar} \quad (\text{RE-030-N-10-B, see page 72})$$

Determination of the correction factor (see page 22):

$$\Delta p_{\text{Assy}} = \frac{0,882}{0,86} \cdot 0,30 \text{ bar} + \frac{0,882}{0,86} \cdot \frac{29}{30} \cdot 0,067 \text{ bar}$$

$$\Delta p_{\text{Assy}} = 0,37 \text{ bar} \leq \Delta p_{\max} = 0,5 \text{ bar}$$

In a clean state, this filter fulfills the requirements and is suitable for the application. No further calculation is necessary. The correct filter designation would be **RF-030-N-10-B-G16**.



Filter Elements 24 - 33



Filter Material – Quality And Properties 26



For Return-Line Filters 27



For Pressure Filters 27



For Spin-On-Filters 28



For Suction Strainers 28

Interchanging STAUFF Filter Elements 29

Order Codes



Special Filter Element Solutions 30

Checklist for the selection of filter housings 31



Filter Elements 32 - 33
For Single, Double and Automatic Filters

Replacement Filter Elements for Applications involving Hydraulic and Lubrication Oils

The STAUFF 4PRO Glass Fibre Elements

The PLUS for customers:

- Longer operating times through higher dirt holding capacity
- Improved energy efficiency through lower differential pressure
- Excellent β values and outstanding β stability

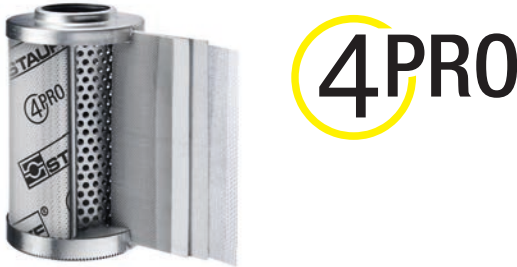

The 4Pro stands for 4 pros that characterise STAUFF glass fibre materials:

- **proACTIVE**
- **proGRESSIVE**
- **proFESSIONAL**
- **proTECTION**

Or simply: **Fo(u)r Protection**

In terms of the β value, STAUFF elements have always exhibited excellent performance. For those who take filtration seriously, there's no other valid approach – the measured values must hold up under any inspection. The elements cannot afford any vulnerabilities. The new generation of elements also have excellent dirt holding capacities. Values that users have been looking for. Values that make it possible for the user to extend operating times thereby providing significant reductions to purchasing costs for elements as well maintenance costs.

Protecting Filter Elements Against Direct Flow Impact

The sensitive filter bellows on filter elements are frequently prone to damage during transportation, storage and filter replacement work. In addition, large particles in the flow of fluid may harm the filter material.

STAUFF offers a solution: SE and RE series filter elements with protective sheath (only available for glass fibre elements). This is a thin, perforated plastic sheet that completely encases the pleats of the filter from the outside as well as making the element more stable. A further positive effect is that the volume of flow is distributed more evenly by the protective sheath, thus ensuring an efficient flow rate.

In its standard version, the foil is printed with the STAUFF 4PRO logo, eliminating any mix-up with other brands. Larger quantities can also be produced with a customised imprint on the sheath.

β value

Key evaluation criteria for filter elements using glass fibre technology are the retention rate (micron rating) the β value, the β stability, the dirt holding capacity and the initial pressure differential. These values are determined using the multipass test established by ISO 16889.

The designation for STAUFF elements typically includes a rating based on filter fineness.

Filter designation β value > 200 according to ISO 4406	$\beta_{(c)} > 200$ ISO 11171	$\beta_{(c)} > 1000$ ISO 11171
03	4,0 $\mu\text{m}_{(c)}$	4,5 $\mu\text{m}_{(c)}$
05	5,0 $\mu\text{m}_{(c)}$	6,0 $\mu\text{m}_{(c)}$
10	8,8 $\mu\text{m}_{(c)}$	11,0 $\mu\text{m}_{(c)}$
20	21,0 $\mu\text{m}_{(c)}$	23,0 $\mu\text{m}_{(c)}$

Filter Material – Quality And Properties

The choice of the right filter material is dependent on different criteria. Among others, this includes the type of application, the filter function, degree of contamination or alternatively the required dirt-hold capacity as well as requirements of chemical or physical resistance. Inorganic Glass Fibre, Polyester, Cellulose, Stainless Fibre Material and Stainless Steel Wire Mesh are used for hydraulic applications.

The following list gives you an overview of how these five filter materials differ with regard to specific properties:



Inorganic Glass Fibre

- Inorganic Glass Fibre based on synthetic fibres with acrylic resin binding
- Large dirt-hold capacity
- Excellent separation efficiency of the finest particles due to the three-dimensional labyrinth structure with deep-bed filtration
- Outstanding price/performance ratio

Micron rating

- 3 ... 25 μm (alternative micron ratings on request)

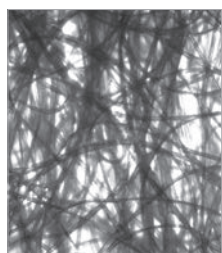

Polyester Fibre

- 100% Polyester Fibres with thermal bonding
- High pressure differential resistance
- Good chemical resistance
- High separation efficiency of the finest particle
- Tear-proof structure

Micron rating

- 3 ... 25 μm (alternative micron ratings on request)

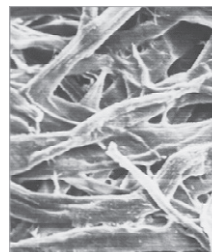

Cellulose Fibre

- Filter material made of Cellulose Fibres with special impregnation
- Variants with lowest price with good dirt-hold capacity
- Not suitable for water based fluids

Micron rating

- 10 ... 50 μm (alternative micron ratings on request)

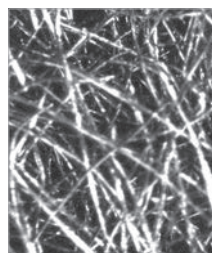

Stainless Fibre

- Sintered Stainless Fibres with three-dimensional labyrinth structure for depth filtration
- Low flow resistance with high dirt-hold capacity
- Excellent chemical and thermal resistance

Micron rating

- 3 ... 25 μm (alternative micron ratings on request)

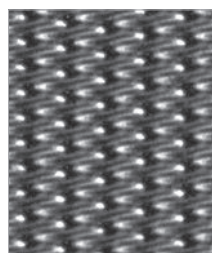

Stainless Mesh

- Wire Mesh fabric made of material 1.4301 or 1.4305 for surface (other material on request)
- Type of weave: square weave or Dutch weave
- Low flow resistance due to large-pored screening surface
- Excellent chemical and thermal resistance

Micron rating

- 10 ... 1000 μm (alternative micron ratings on request)

Replacement Filter Elements for Applications involving Hydraulic and Lubrication Oils

Replacement Filter Element for Return-Line Filters

Filter media

- Inorganic Glass Fibre
- Polyester Fibre
- Cellulose Fibre
- Stainless Fibre
- Stainless Mesh

Micron rating

- see on page 26 Filter Materials

max. Δp^* collapse

- 10 ... 25 bar / 145 ... 362 PSI

Sealing Material

- NBR (Buna-N®)
- FKM (Viton®)
- EPDM

Bypass

- 1 ... 7 bar / 0 ... 101 PSI

End cap

- Plastic / Steel / Stainless Steel (alternative End caps on request)

Note: * Collapse / burst resistance as per ISO 2941.



B

Replacement Filter Element for Pressure Filters

Filter media

- Inorganic Glass Fibre
- Polyester Fibre
- Cellulose Fibre
- Stainless Fibre
- Stainless Mesh

Micron rating

- see on page 26 Filter Materials

max. Δp^* collapse

- 10 ... 210 bar / 145 ... 3045 PSI

Sealing Material

- NBR (Buna-N®)
- FKM (Viton®)
- EPDM

End cap

- Steel / Stainless Steel / Aluminium (alternative End caps on request)

Note: * Collapse / burst resistance as per ISO 2941.



Replacement Filter Elements for Applications involving Hydraulic and Lubrication Oils

Replacement Filter Element for Spin-On-Filters (see on Page 168 - 173)

B



max. Δp *collapse

- 5 ... 10 bar / 72 ... 145 PSI

Sealing Material

- NBR (Buna-N®)

Connection Thread

- BSP / UNF / NPT

Note: * Collapse / burst resistance as per ISO 2941.

Replacement Filter Element for Suction Strainers



Filter media

- Stainless Mesh

Micron rating

- 60, 125, 250 μm

Flow Rate

- 12 - 400 l/min / 3.1 - 104 US GPM

Bypass

- 0,2 bar / 2.9 PSI

End cap

- Aluminium / Plastic

Connection Thread

- BSP / NPT

Note: * Collapse / burst resistance as per ISO 2941.

For details, please see Catalogue No. 10 - Hydraulic Accessories.

Interchanging STAUFF Filter Elements

As well as original Filter Elements for our own filter housings, STAUFF also provides access to a comprehensive range of Replacement Filter Elements. They match the quality and can be installed in the products of for example:

- Argo-Hytos
- Donaldson
- Eppensteiner Bosch Rexroth
- Fairey Arlon
- Hydac
- Mahle
- Internormen
- Pall
- Parker
- Other types are available on request

STAUFF offers many options for filter conversion, design and calculation and supports interested parties and customers with the design of efficient solutions:

- Online filter search with more than 65000 data sets under www.filterinterchange.com
- Offline filter database with deposited measurements, filter surfaces and drawings
- Filter selection software for easy filter design and calculation

Thanks to their excellent dirt-hold capacity, all of the filter products supplied by STAUFF have an impressive long service life and high β value stability:

- Inorganic glass fibre, filter paper, stainless fibre (micron ratings between 3 μm and 25 μm respectively) as well as stainless mesh (micron ratings between 10 μm and 1000 μm)
- Maximum differential pressure depending on filter media and application for the options 16 bar / 232 PSI, 30 bar / 435 PSI or 210 bar / 3000 PSI.

Your local STAUFF Distributor will assist you interchanging to STAUFF elements.

B

Find the suitable STAUFF replacement filter element at

www.filterinterchange.com



It's this easy:



search



enquire



save

Your advantages:

- Over 65000 datasets from various manufacturers
- Conversion for all common filter brands and types
- Watch list function for storing search results
- Request price and delivery time with enquiry history

Order Codes

RE - 045 - G - 20 - B / X - 123456

① ② ③ ④ ⑤ ⑥ ⑦

① Type

Series	Filter Element
Argo-Hytos High Pressure Filter Element	SD
Argo-Hytos Medium Pressure Filter Element	MD
Argo-Hytos Return-Line Filter Element	RD
Argo-Hytos Suction-Line Filter Element	AD
Eppensteiner Bosch Rexroth High Pressure Filter Element	SS
Eppensteiner Bosch Rexroth Return-Line Filter Element	RS
Eppensteiner Bosch Rexroth Low Pressure Filter Element	LS
Fairey Arlon High Pressure Filter Element	SA
Fairey Arlon Return-Line Filter Element	RA
Hydac High Pressure Filter Element	SE
Hydac Return-Line Filter Element	RE
Mahle High Pressure Filter Element	SL
Mahle Low Pressure Filter Element	ML
Mahle Return-Line Filter Element	RL
Internormen High Pressure Filter Element	SN
Internormen Return-Line Filter Element	RN
Pall High Pressure Filter Element	SP
Pall Return-Line Filter Element	RP
Medium Pressure Filter Element according to standard	NL
Return-Line Filter Element according to standard	NR
Spin-On Filter Element	SFC
Special Element STAUFF	SXX

Note: Other series on request

② Nominal Size

Depending on the nominal flow or element length

③ Filter Material and Pressure Setting

Stainless Fibre, high collapse pressure	A, M
Stainless Mesh, low collapse pressure	B, S
Polyester Fibre, high collapse pressure	C
Filter Paper, low collapse pressure	D, K, L, N
Inorganic Glass Fibre, low collapse pressure	E, G, Q
Inorganic Glass Fibre, high collapse pressure	F, H
Stainless Mesh, high collapse pressure	R, T, W

④ Micron Rating

Stainless Mesh	
10 μm	10
20 μm	20
25 μm	25
40 μm	40
50 μm	50
60 μm	60
80 μm	80
100 μm	100
125 μm	125
150 μm	150
200 μm	200
500 μm	500
1000 μm	1000
Stainless Stainless Fibre	
3 μm	03
5 μm	05
10 μm	10
20 μm	20
25 μm	25
Filter paper	
10 μm	10
20 μm	20
50 μm	50

④ Micron Rating

Inorganic Glass Fibre	
3 μm	03
5 μm	05
10 μm	10
15 μm	15
20 μm	20
25 μm	25
Polyester Fibre	
3 μm	03
5 μm	05
10 μm	10
20 μm	20
25 μm	25

Note: Other micron ratings on request

⑤ Sealing Material

NBR (Buna-N®)	B
FKM (Viton®)	V
EPDM	E

Note: Other sealing materials on request.

⑥ Design Code

Only for information	X
----------------------	----------

⑦ STAUFF Special Number

If element varies from the standard type	X
--	----------

Special Filter Element Solutions



Special Ammonia Filter Element



High Pressure Block with Threaded Filter Element

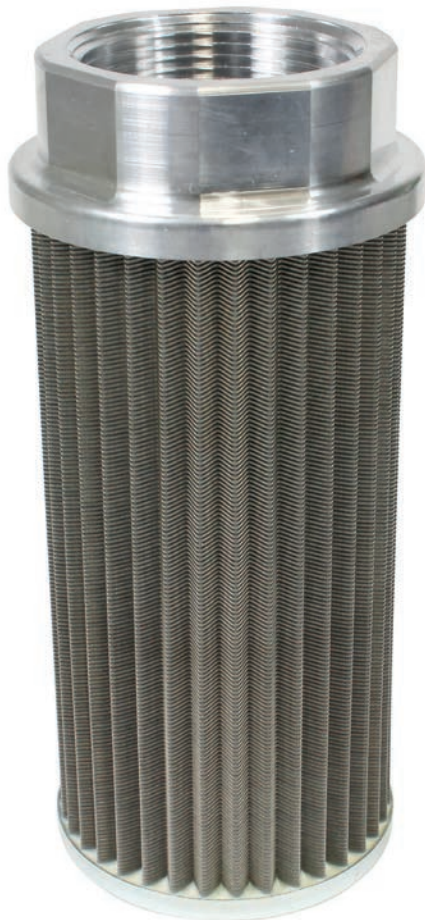

Special Suction Strainer



Filter Element with Bypass and Special Sealing



High Pressure Threaded Elements

Custom-designed Filter element solutions in addition to the Original-STAUFF-Filtartion Technology range according to customers specifications or based on STAUFF developments.

If you have similar requirements please contact STAUFF.

B

Checklist for the selection of filter housings

Please use the following Checklist as a guideline when preparing an enquiry for the selection of filter housings. Scan or copy the page from the catalogue, print and com-

plete it with as much information as possible, before sending it by email or fax to the closest STAUFF branch office. If possible, please also let us know the quantities required,

and if the enquiry is for a one-time or recurring demand. We look forward to hearing from you, and are always available for consultation, when required.

Information on the fluid in use					
Type of fluid	<input type="text"/>	Brand	<input type="text"/>	ISO designation	
Fluid viscosity	<input type="text"/>	<input type="checkbox"/>	mm ² /sec	<input type="checkbox"/>	cSt
Fluid temperature	<input type="text"/>	°C	<input type="checkbox"/>	°F	<input type="checkbox"/>
	<input type="text"/>		In cold condition	<input type="text"/>	In warm condition
Information on the filter housing					
Position in the hydraulic system	<input type="checkbox"/>	Suction line	<input type="checkbox"/>	Pressure line	<input type="checkbox"/>
					Return line
Operating pressure	<input type="text"/>	<input type="checkbox"/>	bar	<input type="checkbox"/>	PSI
Nominal flow	<input type="text"/>	<input type="checkbox"/>	l/min	<input type="checkbox"/>	US GPM
Valve	<input type="checkbox"/>	No, not required			
	<input type="checkbox"/>	Yes, the following type:			
		<input type="checkbox"/>	Bypass valve	<input type="checkbox"/>	Non-return valve
				<input type="checkbox"/>	Reverse flow valve
				<input type="checkbox"/>	Multi-function valve
Clogging indicator	<input type="checkbox"/>	No, not required			
	<input type="checkbox"/>	Yes, the following type:			
		<input type="checkbox"/>	Visual	<input type="checkbox"/>	Electrical
				<input type="checkbox"/>	Visual-electrical
Connection type and size	<input type="text"/>				
Sealing material	<input type="checkbox"/>	NBR (Buna®)	<input type="checkbox"/>	FKM (Viton®)	<input type="text"/>
					Other
Information on the filter element					
Filter media	<input type="checkbox"/>	Inorganic Glass Fibre	<input type="checkbox"/>	Polyester Fibre	<input type="checkbox"/>
					Cellulose Fibre
				<input type="checkbox"/>	Stainless Fibre
				<input type="checkbox"/>	Stainless Mesh
Micron rating	<input type="text"/>	µm			
Cleanliness level	<input type="text"/>	(to ISO 4406)			
Information on the application	<input type="text"/>				
Information on the ambient conditions	<input type="text"/>				
Additional information and requirements	<input type="text"/>				

B

Replacement Filter Elements for Single, Double and Automatic Filters

Screw-In and Plug-In Elements ■ Type SFK

B



We produce high-quality Screw-In and Plug-In Elements in Stainless Steel design or in Plastic design. They fit into the most common single, double and automatic filters.

Length

- 220 mm ... 750 mm / 8.66 in ... 29.53 in

Diameter

- 30 mm / 1.18 in

Filter media

- Stainless Mesh

Micron rating

- 10 ... 200 µm (alternative micron ratings on request)

End cap

- Stainless Steel / Plastic

Application

- For lubricating oils, heavy fuels, water, chemicals and cooling lubricants

Star-Pleated Elements, Basket and Ring Sieves ■ Types SBS and SBK



We deliver high-quality Star- Pleated Elements, Basket and Ring Sieves in Stainless Steel design with particularly pleated filter media which offer a very good filtrate quality and aw long durability.

Length

- 95 mm ... 390 mm / 3.74 in ... 15.35 in

Diameter

- 65 mm ... 85 mm / 2.56 in ... 3.35 in

Filter media

- Stainless Mesh

Micron rating

- 10 ... 200 µm (alternative micron ratings on request)

End cap

- Stainless Steel

Application

- For lubricating oils, heavy fuels, water, chemicals and cooling lubricants

Heavy Fuel Elements ■ Type SFK-439



STAUFF Heavy Fuel Elements separate particles from the fluid flow as the last filtration step before direct injection to the engine room / combustor.

Length

- 439 mm / 17.28 in

Diameter

- 48 mm / 1.89 in

Filter media

- Stainless Mesh

Micron rating

- 6 µm or 10 µm

End cap

- Stainless Steel

Application

- Separation of particles from the fluid flow as the last filtration step before direct injection to the engine room / combustor.

Replacement Filter Elements for Single, Double and Automatic Filters

Paper, Fibreglass and Polyester Elements ■ Type SBS-124

Due to the pleated design of STAUFF Paper Elements, they can offer a large filter area in a small place and with a long durability. The cover made of Polyester allows a safe treatment during the installation and the demounting without damaging the filter media.

Length

- 254 mm, 500 mm or 750 mm / 10.00 in , 19.69 in oder 29.53 in (alternative lengths on request)

Diameter

- 124 mm / 4.88 in

Filter media

- Paper, Fibreglass and Polyester (Stainless Mesh on request)

Micron rating

- 10 µm or 50 µm (alternative micron ratings on request)

End cap

- Steel, zinc plated or Stainless Steel

Application

- Bypass and flushing filter for automatic filters and double filters in the field of lubricating oil



B

Plastic Elements ■ Types SFK-320 and SFK-445

STAUFF Plastic Elements have a special cloth and a special format which ensure the safety and the optimal protection of the motors. The molded end caps allow a quick installation and demounting as they can be easily connected.

Length

- 320 mm or 445 mm / 12.59 in oder 17.52 in

Diameter

- 19 mm ... 33 mm / 0.75 in ... 1.29 in

Filter media

- Plastic (Stainless Mesh on request)

Micron rating

- 25 µm or 31 µm

End cap

- Plastic

Application

- Pre-filter of motors



Multimantle Elements ■ Type SBM

Multimantle Elements in different types and sizes complete the STAUFF exchange program.

Length

- 128 mm ... 723 mm / 5.03 in ... 28.46 in

Diameter

- 86 mm ... 230 mm / 3.39 in ... 9.05 in

Filter media

- Stainless Mesh

Micron rating

- 10 µm ... 2000 µm

End cap

- Aluminium

Application

- Multimantle filter elements are generally used in marine applications for filtering fuels and lubricants as well as water. The elements are also used in the processing industry for purifying water, oils, coolants and chemicals.



Overview Pressure Filters 36

SF / SF-TM / SFA / SFZ / SMPF

High Pressure Filters (Inline) SF 37 - 40
 Max. 420 bar / 6000 PSI
 Max. 1135 l/min / 300 US GPM

Technical Data / Dimensions 38 - 39

Order Code - High Pressure Filter 40

Order Code - Filter Elements 40

High Pressure Filters (Top-mounted) SF-TM 41 - 44
 Max. 315 bar / 4560 PSI
 Max. 1135 l/min / 300 US GPM

Technical Data / Dimensions 42 - 43

Order Code - High Pressure Filter 44

Order Code - Filter Elements 44

High Pressure Filters (Sandwich) SFZ 45 - 48
 Max. 315 bar / 4560 PSI
 Max. 30 l/min / 8 US GPM

Technical Data / Dimensions 46 - 47

Order Code - High Pressure Filter 48

Order Code - Filter Elements 48

Medium Pressure Filters (Inline) SFA 49 - 52
 Max. 160 bar / 2320 PSI
 Max. 240 l/min / 70 US GPM

Technical Data / Dimensions 50 - 51

Order Code - Medium Pressure Filter 52

Order Code - Filter Elements 52

Valves (for SF / SF-TM / SFA / SFZ) 53

HV

Clogging Indicators (for SF / SF-TM / SFA / SFZ) 54 - 55

HI

Flow Characteristics 56 - 58

SF / SF-TM / SFA / SFZ

Medium Pressure Filters (Inline) SMPF 59 - 62
 Max. 110 bar / 1600 PSI
 Max. 90 l/min / 25 US GPM

Technical Data / Dimensions 60 - 61

Order Code - Medium Pressure Filter 62

Order Code - Filter Elements 62

Clogging Indicators 63

HIM

Flow Characteristics 64

SMPF

Checklist for the selection of filter housings 65

Description

STAUFF Pressure Filters were designed for in-line mounting in hydraulic and lubrication systems. They are placed behind the pump and clean the hydraulic oil before it flows through down-stream components like valves, cylinders and so on. The main reason for pressure filtration is the protection of downstream, sensitive components. Eroded particles from the pump are immediately filtered out of the hydraulic oil. Besides working as a protection filter, Pressure Filters also help to maintain the required purity class.

Because it is placed right behind the pump, a Pressure Filter has to withstand the maximum system pressure. The filter element in the Pressure Filter also has to withstand the loads and is more intricately constructed, for example as a Return-Line filters element.

STAUFF Pressure Filters are available in many different sizes, connections and configurations.

Media Compatibility

- Mineral oils, other fluids on request

Options and Accessories

Valve

- Also available with bypass, reverse flow, non-return or multi-function valve

Clogging Indicator

- On request with visual, electrical or visual-electrical differential pressure indicator



Type SF

- High Pressure Filter designed for in-line assembly
- Threaded mounting holes on top and fluid ports on side of head
- Also available as toplayer, with bowl in two-part style

- Operating pressure: max. 420 bar / 6000 PSI
- Nominal flow rate: max. 1135 l/min / 300 US GPM
- Materials: Filter head: Spheroidal Graphite Cast Iron, Filter bowl: Cold Drawn Steel
- Connections: option of BSP, NPT, SAE thread or SAE flange (ISO 6162-1/2)



Type SFA

- Medium Pressure Filter designed for in-line assembly
- Threaded mounting holes on top and fluid ports on side of head
- Low weight and compact design

- Operating pressure: max. 160 bar / 2320 PSI
- Nominal flow rate: max. 240 l/min / 70 US GPM
- Materials: Filter head: Cast Aluminium, Filter bowl: Aluminium
- Connections: option of BSP, NPT, SAE-thread or SAE flange (ISO 6162-1)



Type SF-TM

- High Pressure Filter designed for manifold mounting
- Mounting holes and fluid ports on top of head
- Also available as toplayer, with bowl in two-part style

- Operating pressure: max. 315 bar / 4560 PSI
- Nominal flow rate: max. 1135 l/min / 300 US GPM
- Materials: Filter head: Spheroidal Graphite Cast Iron or rather Free Cutting Steel, Filter bowl: Cold Drawn Steel



Type SMPF

- Medium Pressure Filter designed for in-line assembly

- Operating pressure: max. 110 bar / 1600 PSI
- Nominal flow rate: max. 90 l/min / 25 US GPM
- Materials: Filter head and bowl: Aluminium
- Connections: BSP, SAE-thread



Type SFZ

- High Pressure Filter designed for sandwich plate mounting
- Available as right or left version

- Operating pressure: max. 315 bar / 4560 PSI
- Nominal flow rate: max. 30 l/min / 8 US GPM
- Materials: Filter head: Free Cutting Steel, Filter bowl: Cold Drawn Steel

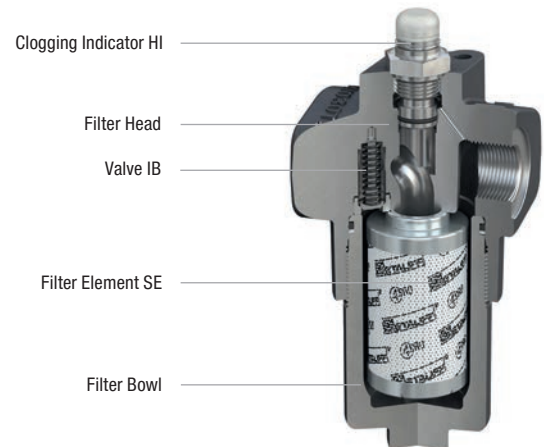
High Pressure Filters ■ Type SF

C
Product Description

STAUFF SF series High Pressure Filters are designed for in-line hydraulic applications, with a maximum operating pressure of 420 bar / 6000 PSI. Used together with STAUFF SE series Filter Elements, a high efficiency of contaminant removal is assured. The high dirt-hold capacity of the elements ensures long service life and, as a result, reduced maintenance costs.

Technical Data
Construction

- Designed for in-line assembly, with threaded mounting holes on top of the head.

Materials

- Filter head: Spheroidal Graphite Cast Iron
- Filter bowl: Cold Drawn Steel
- O-rings: NBR (Buna-N®)
FKM (Viton®)
EPDM (Ethylene-Propylene-Diene-Monomer-Rubber)
- Support ring: PTFE (Polytetrafluoroethylene)

Port Connections

- BSP
- NPT
- SAE O-ring thread
- SAE 3000 PSI (Code 61) flange
- SAE 6000 PSI (Code 62) flange

Other port connections available on request.

Operating Pressure

- Max. 420 bar / 6000 PSI

Burst Pressure

- Min. 1260 bar / 18275 PSI

Temperature Range

- -20 °C ... +100 °C / -44 °F ... +212 °F
(Short term up to +110 °C / +230 °F)

Filter Elements

- Specifications see page 40

Media Compatibility

- Mineral oils, other fluids on request

Options and Accessories
Valves

- Bypass valve: Allows unfiltered oil to bypass the contaminated element once the opening pressure has been reached, a differential pressure of $6^{+0.5}$ bar / $87^{+7.25}$ PSI Δp is the standard setting. Other settings available upon request.
- Reverse flow valve: Allows reverse flow through the filter head without backflushing the element.
- Non-return valve: Prevents draining of the delivery line during element change.
- Multi-function valve: Opening pressure $6^{+0.5}$ bar / $87^{+7.25}$ PSI
Bypass, reverse flow capability and non-return valve combined in one valve.

Clogging Indicators

- Standard actuating pressure: $5_{-0.5}$ bar / $72.5_{-7.25}$ PSI Δp
Other actuating pressure settings are available upon request.
- Available indicators: Visual
Electrical
Visual-electrical (24 V DC, 110 V AC, 230 V AC versions)
Double Visual-electrical (24 V DC)

High Pressure Filters - Type SF

G

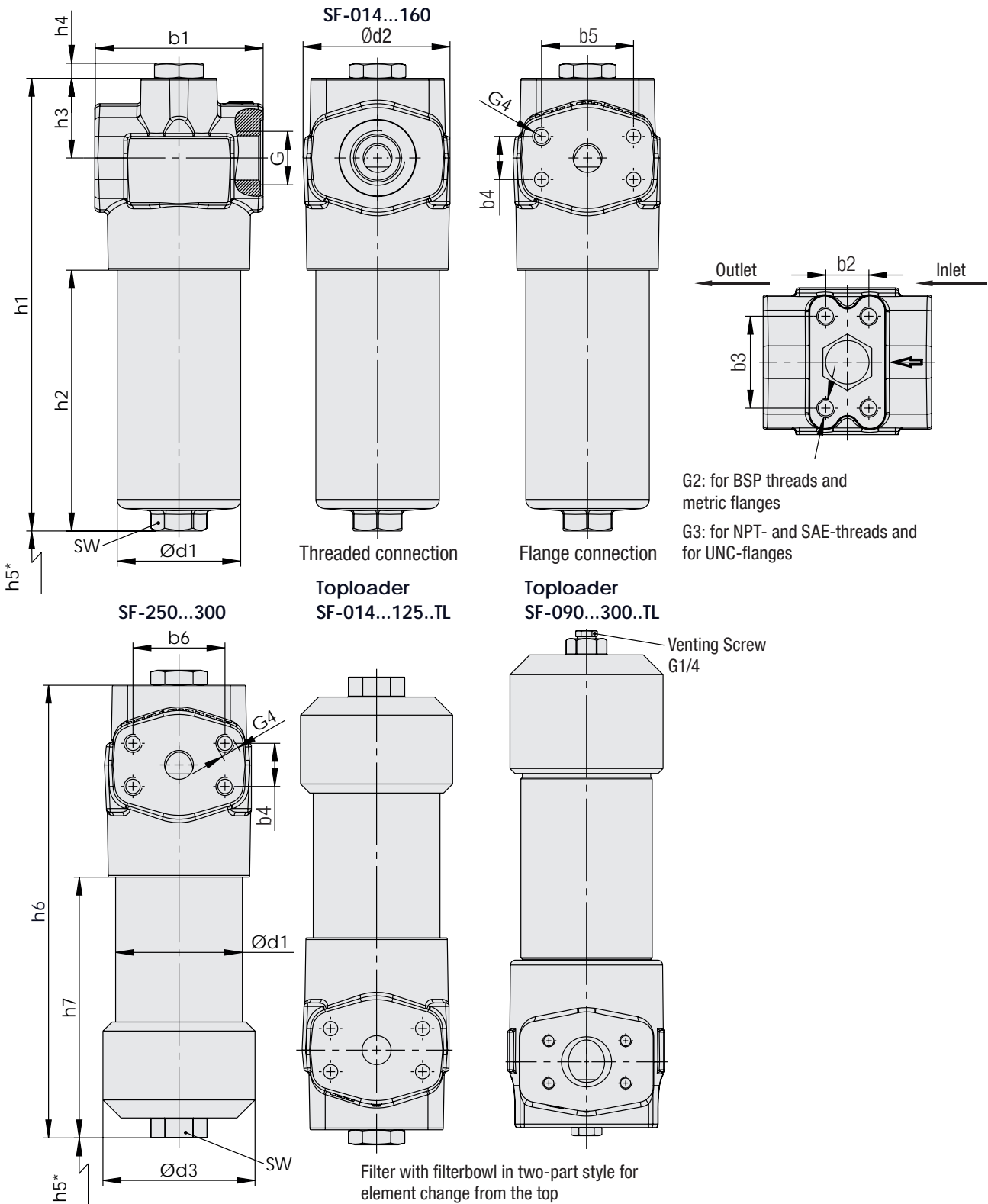

* recommended space for element change

High Pressure Filters ■ Type SF

Thread Connection G	Filter Size SF									
	014	030	045	070	125	090	130	160	250	300
BSP	3/4	3/4	1-1/4	1-1/4	1-1/4	1-1/2	1-1/2	1-1/2	1-1/2	1-1/2
NPT	3/4	3/4	1-1/4	1-1/4	1-1/4	1-1/2	1-1/2	1-1/2	1-1/2	1-1/2
SAE O-ring Thread	1-1/16-12	1-1/16-12	1-5/8-12	1-5/8-12	1-5/8-12	1-7/8-12	1-7/8-12	1-7/8-12	1-7/8-12	1-7/8-12
SAE Flange 3000 PSI	3/4	3/4	1-1/4	1-1/4	1-1/4	1-1/2	1-1/2	1-1/2	1-1/2	1-1/2
SAE Flange 6000 PSI	3/4	3/4	1-1/4	1-1/4	1-1/4	1-1/2	1-1/2	1-1/2	1-1/2	1-1/2
Weight (kg/lbs) incl. Elements with Filter Bowl in One-Part Style	5	5,9	10,3	12	-	26,4	30,2	34,9	-	-
	11	13	22,7	26,5	-	58,2	66,6	76,9	-	-
Weight (kg/lbs) incl. Elements with Filter Bowl in Two-Part Style	5,6	6,6	12,2	13,7	20	31,4	-	38,7	48,4	56,7
	12,3	14,6	26,9	30,2	44,1	69,2	-	85,3	106,7	125

Dimensions (mm/in)	Filter Size SF											
	014	030	045	070	125	090	130	160	250	300		
b1	93	93	126	126	126	160	160	160	160	160		
	3.66	3.66	4.96	4.96	4.96	6.29	6.29	6.29	6.29	6.29		
d2	81	81	120	120	120	156	156	156	156	156		
	3.19	3.19	4.72	4.72	4.72	6.14	6.14	6.14	6.14	6.14		
h3	44	44	44,5	44,5	44,5	66,5	66,5	66,5	66,5	66,5		
h4	1.73	1.73	1.75	1.75	1.75	2.62	2.62	2.62	2.62	2.62		
	12,5	12,5	12,5	12,5	12,5	12,5	12,5	12,5	12,5	12,5		
with Filter Bowl in One-Part Style Type SF	d1	.49	.49	.49	.49	.49	.49	.49	.49	.49		
		68	68	95	95	-	130	130	130	130		
	h1	2.68	2.68	3.74	3.74	-	5.12	5.12	5.12	5.12		
		184	250	233,5	292	-	317,5	411	488,5	-	-	
	h2	7.24	9.84	9.19	11.51	-	12.5	16.18	19.23	-	-	
		78	144	102,5	161,5	-	148	241,5	319	-	-	
	h5	3.07	5.67	4.03	6.35	-	5.83	9.5	12.56	-	-	
		rec.*	100	170	140	200	-	190	290	360	-	-
			3.94	6.69	5.51	7.87	-	7.48	11.42	14.17	-	-
	min.*	85	85	120	120	-	150	150	150	-	-	
		3.35	3.35	4.72	4.72	-	5.91	5.91	5.91	-	-	
	Hex	27	27	32	32	-	36	36	36	36	36	
	1.06	1.06	1.26	1.26	-	1.42	1.42	1.42	1.42	1.42		
with Filter Bowl in Two-Part Style Type SF...TL	d1	70	70	101,6	101,6	101,6	133	-	133	133	133	
		2.76	2.76	4	4	4	5.24	-	5.24	5.24	5.24	
	d3	84	84	115	115	115	155	-	155	155	155	
		3.31	3.31	4.53	4.53	4.53	6.10	-	6.10	6.10	6.10	
	h5	65	130	100	160	340	120	-	290	425	590	
		2.56	5.12	3.94	6.30	13.39	4.72	-	11.42	16.73	23.23	
	h6	184	250	234	294	475	332	-	503	659	824	
		7.27	9.84	9.21	11.57	18.7	13.1	-	19.8	25.9	32.4	
	h7	78	144	103	163	344	154,5	-	325,5	481,5	646,5	
		3.07	5.67	4.06	6.42	13.54	6.08	-	12.82	18.96	25.45	
Hex	27	27	32	32	32	36	-	36	36	36		
	1.06	1.06	1.26	1.26	1.26	1.42	-	1.42	1.42	1.42		
Dimensions SAE Flange 3000 PSI	b4	22,3	22,3	30,2	30,2	30,2	35,7	35,7	35,7	35,7		
		.88	.88	1.19	1.19	1.19	1.41	1.41	1.41	1.41	1.41	
	b5	47,6	47,6	58,7	58,7	58,7	69,9	69,9	69,9	69,9		
	1.19	1.19	2.32	2.32	2.32	2.75	2.75	2.75	2.75	2.75		
G4	M10 x 15	M10 x 15	M10 x 18			M12 x 20						
	3/8-16 UNC	3/8-16 UNC	7/16-14 UNC			1/2-13 UNC						
Dimensions SAE Flange 6000 PSI	b4	23,8	23,8	31,8	31,8	31,8	36,5	36,5	36,7	36,7		
		.94	.94	1.25	1.25	1.25	1.44	1.44	1.45	1.45	1.45	
	b5	50,8	50,8	66,6	66,6	66,6	79,3	79,3	79,4	79,4		
	2.00	2.00	2.62	2.62	2.62	3.12	3.12	3.13	3.13	3.13		
G4	M10 x 15	M14 x 17			M16 x 20							
	3/8-16 UNC	1/2-13 UNC			5/8-11 UNC							

Reference: rec.*: Recommended | min.*: Minimum

Dimensions (mm/in)	Filter Size SF										
	014	030	045	070	125	090	130	160	250	300	
T	b2	23,8	23,8	31,6	31,6	31,6	36,7	36,7	36,7	36,7	
		.94	.94	1.24	1.24	1.24	1.45	1.45	1.45	1.45	1.45
	b3	50,8	50,8	66,7	66,7	66,7	79,4	79,4	79,4	79,4	
		2.00	2.00	2.63	2.63	2.63	3.13	3.13	3.13	3.13	3.13
TH (optional)	G2	M10 x 15		M14 x 17			M16 x 20				
	G3	3/8-16 UNC x .59			1/2-13 UNC x .79			5/8-11 UNC x .79			
	b2	32	32	35	35	35	60	60	60	60	
		1.26	1.26	1.38	1.38	1.38	2.36	2.36	2.36	2.36	2.36
	b3	56	56	85	85	85	115	115	115	115	
		2.20	2.20	3.35	3.35	3.35	4.53	4.53	4.53	4.53	4.53
G2	M6 x 9		M10 x 15			M12 x 20					
G3	1/2-28 UNF x .35		3/8-24 UNF x .59			1/2-20 UNF x .79					

High Pressure Filter Housings / Complete Filters ■ Type SF

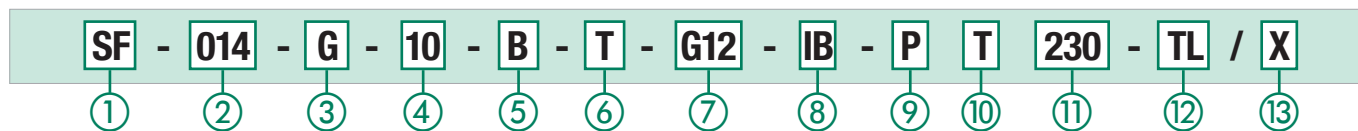

① Type

High Pressure Filter **SF**

② Group

Flow	Size
60 l/min / 14 US GPM	014
110 l/min / 30 US GPM	030
160 l/min / 45 US GPM	045
240 l/min / 70 US GPM	070
330 l/min / 90 US GPM	090
475 l/min / 125 US GPM	125
500 l/min / 132 US GPM	130
660 l/min / 160 US GPM	160
990 l/min / 250 US GPM	250
1135 l/min / 300 US GPM	300

Note: Exact flow will depend on the selected filter element.
For technical data please see pages 57 / 58.

③ Filter Material

Material	max. Δp*collapse	Micron ratings available	Code
Without filter element	-	-	0
Inorg. glass fibre	25 bar / 363 PSI	3, 5, 10, 20	G
Inorg. glass fibre	210 bar / 3045 PSI		H
Stainless fibre	210 bar / 3045 PSI		A
Stainless mesh	30 bar / 435 PSI	25, 50, 100, 200	S

Note: * Collapse/burst resistance as per ISO 2941.

④ Micron Rating

3 μm	03
5 μm	05
10 μm	10
20 μm	20
25 μm	25
50 μm	50
100 μm	100
200 μm	200

Note: Other micron ratings on request.

⑤ Sealing Material

NBR (Buna-N®)	B
FKM (Viton®)	V
EPDM	E

Note: Other sealing materials on request.

⑥ Connecting Flange

Type T	T
Type TH (optional)	TH

⑦ Connection Style

Connection Style	Thread Style	Group 014	Group 030	Code	Group 045	Group 070	Group 125	Code	Group 090	Group 130	Group 160	Group 250	Group 300	Code
BSP	-	3/4		G12	1-1/4			G20	1-1/2					G24
BSP	-	1		G16	1-1/2			G24	-					-
NPT	-	3/4		N12	1-1/4			N20	1-1/2					N24
SAE O-ring Thread	-	1-1/16-12		U12	1-5/8-12			U20	1-7/8-12					U24
SAE Flange 6000 PSI	metric	3/4		C612M	1-1/4			C620M	1-1/2					C624M
SAE Flange 6000 PSI	UNC	3/4		C612U	1-1/4			C620U	1-1/2					C624U
SAE Flange 3000 PSI	metric	3/4		C312M	1-1/4			C320M	1-1/2					C324M
SAE Flange 3000 PSI	UNC	3/4		C312U	1-1/4			C320U	1-1/2					C324U
SAE Flange 3000 PSI	metric	1		C316M	-			-	2					C332M
SAE Flange 3000 PSI	UNC	1		C316U	-			-	2					C332U
SAE-Flange 6000 PSI	metric	-		-	-			-	2					C632M
SAE-Flange 6000 PSI	UNC	-		-	-			-	2					C632U

Note: Other port connections on request. Bold types identify preferred connection styles.

⑧ Valve

Without integrated Bypass valve	IO
Without valve	0
Integrated Bypass valve	IB
Bypass valve	B
Reverse flow valve	R
Non-return valve	N
Multi-function valve	M

⑨ Clogging Indicator

Without clogging indicator	0
Visual, with automatic reset	A
Visual, with manual reset	V
Electrical	E
Electrical, Deutsch plug	ED
Visual-electrical	P
Double Visual-electrical	D024

⑩ Thermostop

Without thermostop	none
With thermostop	T

⑪ Voltage (only for Code P)

24 V DC	024
110 V AC	110
230 V AC	230

⑫ Style Filter Bowl

With bowl in one-part style	none
Toploader, with bowl in two-part style	TL

Note: Group size SF-250 and SF-300 only available in TL-version.

With drain plug available on request.

Group size SF-130 only available in one-part style.

Group size SF-125 only available in two-part style.

⑬ Design Code

Only for information	X
----------------------	----------

Filter Elements ■ Type SE

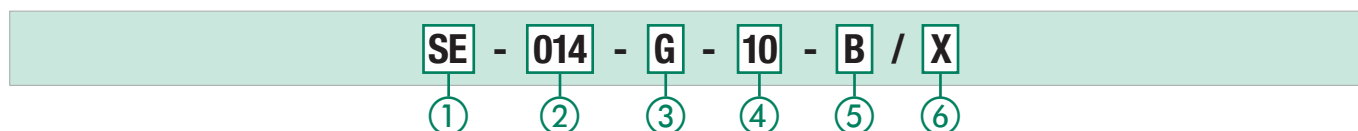

① Type

Filter Element Series **SE**

② Group

According to filter housing

③ Filter Material

Material	max. Δp*collapse	Micron ratings available	Code
Inorganic glass fibre	25 bar / 363 PSI	3, 5, 10, 20	G
Inorganic glass fibre	210 bar / 3045 PSI		H
Stainless fibre	210 bar / 3045 PSI		A
Stainless mesh	30 bar / 435 PSI	25, 50, 100, 200	S

Note: * Collapse/burst resistance as per ISO 2941.

④ Micron Rating

3 μm	03
5 μm	05
10 μm	10
20 μm	20
25 μm	25
50 μm	50
100 μm	100
200 μm	200

Note: Other micron ratings on request.

⑤ Sealing Material

NBR (Buna-N®)	B
FKM (Viton®)	V
EPDM	E

Note: Other sealing materials on request.

⑥ Design Code

Only for information	X
----------------------	----------

High Pressure Filters ■ Type SF-TM



C

Product Description

STAUFF SF-TM series High Pressure Filters are designed for manifold block mounting hydraulic applications, with a maximum operating pressure of 315 bar / 4560 PSI. Used together with STAUFF SE series Filter Elements, a high efficiency of contaminant removal is assured. The high dirt-hold capacity of the elements ensures long service life and, as a result, reduced maintenance costs.

Technical Data
Construction

- Designed for manifold mounting, with mounting holes and fluid ports on top of the head.

Materials

- Filter head: SF-TM-014 ... 125 Free Cutting Steel
SF-TM-090 ... 300 Spheroidal Graphite Cast Iron
- Filter bowl: Cold Drawn Steel
- O-rings: NBR (Buna-N®)
FKM (Viton®)
EPDM (Ethylene-Propylene-Diene-Monomer-Rubber)
- Support ring: PTFE (Polytetrafluoroethylene)

Operating Pressure

- Max. 315 bar / 4560 PSI

Burst Pressure

- Min. 945 bar / 13705 PSI

Temperature Range

- -20 °C ... +100 °C / -44 °F ... +212 °F
(Short term up to +110 °C / +230 °F)

Filter Elements

- Specifications see page 44

Media Compatibility

- Mineral oils, other fluids on request

Options and Accessories
Valves

- Bypass valve: Allows unfiltered oil to bypass the contaminated element once the opening pressure has been reached, a differential pressure of $6^{+0.5}$ bar / $87^{+7.25}$ PSI Δp is the standard setting. Other settings available upon request.
- Reverse flow valve: Allows reverse flow through the filter head without backflushing the element.
- Non-return valve: Prevents draining of the delivery line during element change.
- Multi-function valve: Opening pressure $6^{+0.5}$ bar / $87^{+7.25}$ PSI
Bypass, reverse flow capability and non-return valve combined in one valve.

Clogging Indicators

- Standard actuating pressure: $5_{-0.5}$ bar / $72.5_{-7.25}$ PSI Δp
Other actuating pressure settings are available upon request.
- Available indicators: Visual
Electrical
Visual-electrical (24 V DC, 110 V AC, 230 V AC versions)
Double Visual-electrical (24 V DC)

High Pressure Filters ■ Type SF-TM

C

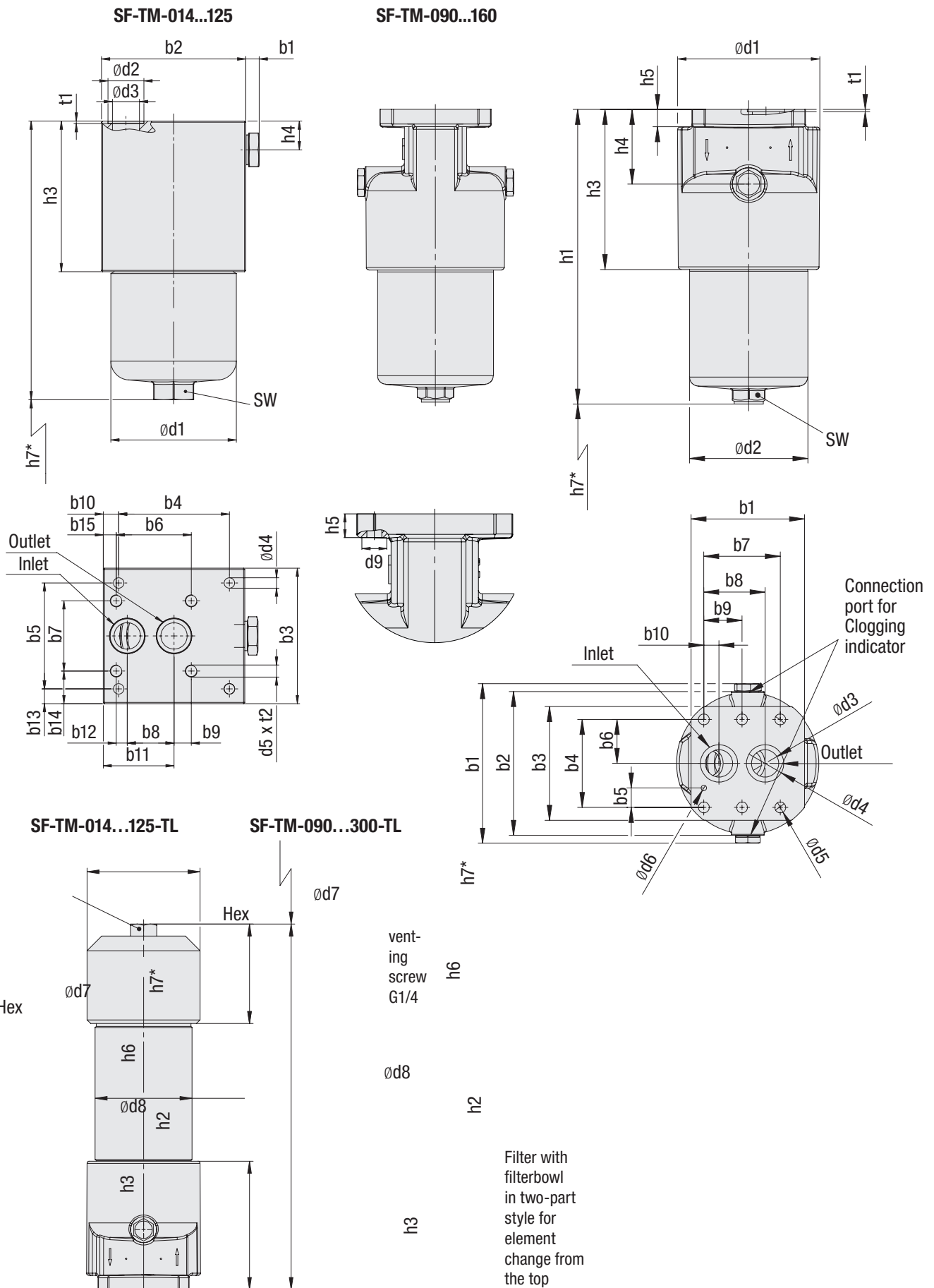

* recommended space for element change

High Pressure Filters ■ Type SF-TM

Dimensions (mm/in)		Filter Size SF-TM										
		014	030	045	070	125	090	130	160	250	300	
b1		6	6	6	6	6	175,6	175,6	175,6	175,6	175,6	
		.24	.24	.24	.24	.24	6.91	6.91	6.91	6.91	6.91	
b2		104	104	115	115	115	158	158	158	158	158	
		4.09	4.09	4.53	4.53	4.53	6.22	6.22	6.22	6.22	6.22	
b3		80	80	110	110	110	125	125	125	125	125	
		3.35	3.35	4.33	4.33	4.33	4.92	4.92	4.92	4.92	4.92	
b4		89	89	90	90	90	96,8	96,8	96,8	96,8	96,8	
		3.50	3.50	3.54	3.54	3.54	3.81	3.81	3.81	3.81	3.81	
b5		31,8	31,8	86	86	86	21,4	21,4	21,4	21,4	21,4	
		1.25	1.25	3.39	3.39	3.39	.84	.84	.84	.84	.84	
b6		-	-	61	61	61	48,4	48,4	48,4	48,4	48,4	
		-	-	2.40	2.40	2.40	1.91	1.91	1.91	1.91	1.91	
b7		-	-	57	57	57	84,1	84,1	84,1	84,1	84,1	
		-	-	2.24	2.24	2.24	3.31	3.31	3.31	3.31	3.31	
b8		31,6	31,6	38	38	38	67,4	67,4	67,4	67,4	67,4	
		1.24	1.24	1.50	1.50	1.50	2.65	2.65	2.65	2.65	2.65	
b9		-	-	14	14	14	42,05	42,05	42,05	42,05	42,05	
		-	-	.55	.55	.55	1.66	1.66	1.66	1.66	1.66	
b10		7,5	7,5	12,5	12,5	12,5	16,7	16,7	16,7	16,7	16,7	
		.30	.30	.49	.49	.49	.66	.66	.66	.66	.66	
b11		55,9	55,9	57,5	57,5	57,5	-	-	-	-	-	
		2.20	2.20	2.26	2.26	2.26	-	-	-	-	-	
b12		-	-	9	9	9	-	-	-	-	-	
		-	-	.35	.35	.35	-	-	-	-	-	
b13		24,1	24,1	12	12	12	-	-	-	-	-	
		.95	.95	.47	.47	.47	-	-	-	-	-	
b14		-	-	26,5	26,5	26,5	-	-	-	-	-	
		-	-	1.04	1.04	1.04	-	-	-	-	-	
b15		-	-	10,5	10,5	10,5	-	-	-	-	-	
		-	-	.41	.41	.41	-	-	-	-	-	
d1		68,2	68,2	95,2	95,2	95,2	156	156	156	156	156	
		2.69	2.69	3.75	3.75	3.75	6.14	6.14	6.14	6.14	6.14	
d2		25,3	25,3	28,6	28,6	28,6	130,2	130,2	130,2	130,2	130,2	
		1.00	1.00	1.13	1.13	1.13	5.13	5.13	5.13	5.13	5.13	
d3		17,5	17,5	21,4	21,4	21,4	30	30	30	30	30	
		.69	.69	.84	.84	.84	1.18	1.18	1.18	1.18	1.18	
d4		8,5	8,5	9	9	9	41	41	41	41	41	
		.33	.33	.35	.35	.35	1.61	1.61	1.61	1.61	1.61	
d5		-	-	7/16-14 UNC	7/16-14 UNC	7/16-14 UNC	12	12	12	12	12	
		-	-				.47	.47	.47	.47	.47	
d6		-	-	-	-	-	6	6	6	6	6	
		-	-	-	-	-	.24	.24	.24	.24	.24	
d7		84	84	115	115	115	155	-	155	155	155	
		3.31	3.31	4.53	4.53	4.53	6.10	-	6.10	6.10	6.10	
d8		70	70	101,6	101,6	101,6	133	-	133	133	133	
		2.76	2.76	4.00	4.00	4.00	5.24	-	5.24	5.24	5.24	
d9		-	-	-	-	-	20	20	20	20	20	
		-	-	-	-	-	.79	.79	.79	.79	.79	
h1		162	228	206	264	446	324	417,5	495	-	-	
		6.38	8.97	8.11	10.39	17.56	12.76	16.44	19.49	-	-	
h2		164	230	206	266	447	338,5	-	509,5	665,5	830,5	
		6.46	9.06	8.11	10.47	17.60	13.3	-	20.1	26.2	32.7	
h3		76	76	93	93	93	178	178	178	178	178	
		2.99	2.99	3.66	3.66	3.66	7.01	7.01	7.01	7.01	7.01	
h4		25	25	25	25	25	82	82	82	82	82	
		.98	.98	.98	.98	.98	3.23	3.23	3.23	3.23	3.23	
h5		-	-	-	-	-	19	19	19	19	19	
		-	-	-	-	-	.75	.75	.75	.75	.75	
h6		64	64	82,5	82,5	82,5	136	-	136	136	136	
		2.52	2.52	3.25	3.25	3.25	5.35	-	5.35	5.35	5.35	
h7	One-Part Style	rec.*	100	170	140	200	380	190	285	360	-	-
		min.*	3.94	6.69	5.51	7.87	14.96	7.48	14.17	14.17	-	-
	Two-Part Style	min.*	85	85	120	120	120	150	150	150	-	-
			3.35	3.35	4.72	4.72	4.72	5.91	5.91	5.91	-	-
	65	130	100	160	340	120	-	290	425	590		
	2.56	5.12	3.94	6.30	13.39	4.72	-	11.42	16.73	23.23		
t1		2	2	2	2	2	3	3	3	3	3	
		.08	.08	.08	.08	.08	.12	.12	.12	.12	.12	
t2		-	-	13	13	13	-	-	-	-	-	
		-	-	.51	.51	.51	-	-	-	-	-	
Hex		27	27	32	32	32	36	36	36	36	36	
		1.06	1.06	1.26	1.26	1.26	1.42	1.42	1.42	1.42	1.42	
Weight (kg/lbs)	One-Part Style		5,7	6,3	11	12,5	17	21,6	25,7	28,8	-	-
			12.5	13.9	24.2	27.8	37.8	48.0	56.7	64.0	-	-
	Two-Part Style		6,6	7,3	13,1	14,6	21	26,5	-	33,8	43,2	54,6
			14.7	16.2	29.1	32.4	46.7	58.9	-	75.1	96	121.3

Reference: rec.*: Recommended | min.*: Minimum

C

High Pressure Filter Housings / Complete Filters ■ Type SF-TM

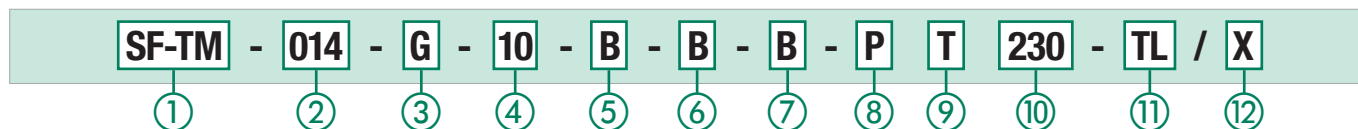

① Type

High Pressure Filter Top Mounted **SF-TM**

② Group

Flow	Size
60 l/min / 14 US GPM	014
110 l/min / 30 US GPM	030
160 l/min / 45 US GPM	045
240 l/min / 70 US GPM	070
330 l/min / 90 US GPM	090
475 l/min / 125 US GPM	125
500 l/min / 132 US GPM	130
660 l/min / 160 US GPM	160
990 l/min / 250 US GPM	250
1135 l/min / 300 US GPM	300

Note: Exact flow will depend on the selected filter element.
For technical data please see pages 57 / 58.

③ Filter Material

Material	max. Δp*collapse	Micron ratings available	Code
Without filter element	-	-	0
Inorg. glass fibre	25 bar / 363 PSI	3, 5, 10, 20	G
Inorg. glass fibre	210 bar / 3045 PSI		H
Stainless fibre	210 bar / 3045 PSI		A
Stainless mesh	30 bar / 435 PSI	25, 50, 100, 200	S

Note: * Collapse/burst resistance as per ISO 2941.

④ Micron Rating

3 µm	03
5 µm	05
10 µm	10
20 µm	20
25 µm	25
50 µm	50
100 µm	100
200 µm	200

Note: Other micron ratings on request.

⑤ Sealing Material

NBR (Buna-N®)	B
FKM (Viton®)	V
EPDM	E

Note: Other sealing materials on request.

⑥ Connection Size

Connection Size	Group			Code				Group				Code
	014	030		045	070	125	090	160	250	300		
Special Flange	Ø17,5mm / Ø.69in			B	Ø21,4mm / Ø .85in			B	Ø30mm / Ø1.18in			B

⑦ Valve

Without valve	0
Bypass valve	B
Reverse flow valve	R
Non-return valve	N
Multi-function valve	M

⑧ Clogging Indicator

Without clogging indicator	0
Visual, with automatic reset	A
Visual, with manual reset	V
Electrical	E
Electrical, Deutsch plug	ED
Visual-electrical	P
Double Visual-electrical	D024

⑨ Thermostop

Without thermostop	none
With thermostop	T

⑩ Voltage (only for Code P)

24 V DC	024
110 V AC	110
230 V AC	230

⑪ Style Filter Bowl

With bowl in one-part style	none
Toploader, with bowl in two-part style	TL

Note: Group size SF-TM-250 and SF-TM-300 only available in TL-version.

⑫ Design Code

Only for information	X
----------------------	----------

Filter Elements ■ Type SE

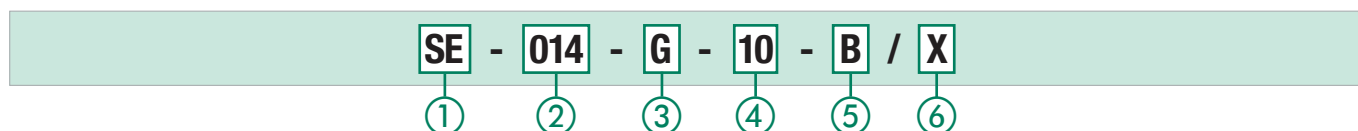

① Type

Filter Element Series **SE**

② Group

According to filter housing

③ Filter Material

Material	max. Δp*collapse	Micron ratings available	Code
Inorganic glass fibre	25 bar / 363 PSI	3, 5, 10, 20	G
Inorganic glass fibre	210 bar / 3045 PSI		H
Stainless fibre	210 bar / 3045 PSI		A
Stainless mesh	30 bar / 435 PSI	25, 50, 100, 200	S

Note: * Collapse/burst resistance as per ISO 2941.

④ Micron Rating

3 µm	03
5 µm	05
10 µm	10
20 µm	20
25 µm	25
50 µm	50
100 µm	100
200 µm	200

Note: Other micron ratings on request.

⑤ Sealing Material

NBR (Buna-N®)	B
FKM (Viton®)	V
EPDM	E

Note: Other sealing materials on request.

⑥ Design Code

Only for information	X
----------------------	----------

High Pressure Filters ■ Type SFZ



C

Product Description

STAUFF SFZ series High Pressure Filters are designed for sandwich plate mounting in manifold block mounting hydraulic applications, with a maximum operating pressure of 315 bar / 4560 PSI. Used together with STAUFF SE series Filter Elements, a high efficiency of contaminant removal is assured. The high dirt-hold capacity of the elements ensures long service life and, as a result, reduced maintenance costs.

Technical Data
Construction

- Designed for sandwich plate mounting

Materials

- Filter head: Free Cutting Steel
- Filter bowl: Cold Drawn Steel
- O-rings: NBR (Buna-N®)
FKM (Viton®)
EPDM (Ethylene-Propylene-Diene-Monomer-Rubber)
- Support ring (bowl): PTFE (Polytetrafluoroethylene)

Connecting Port

- According to ISO 4401-03-02-0-05 NG6 / DIN24340-A6 / Cetop R 35 H (Ref.: NFPA/ANSI D03)

Operating Pressure

- Max. 315 bar / 4560 PSI

Burst Pressure

- Min. 945 bar / 13705 PSI

Temperature Range

- -20 °C ... +100 °C / -44 °F ... +212 °F
(Short term up to +110 °C / +230 °F)

Filter Elements

- Specifications see page 44

Media Compatibility

- Mineral oils, other fluids on request

O-ring for connection ports

- 9x1,7 (4x included in delivery)

Options and Accessories
Clogging Indicator

- Standard actuating pressure: 5_{-0,5} bar / 72.5_{-7,25} PSI Δp
Other actuating pressure settings are available upon request.
- Available indicators: Visual
Electrical
Visual-electrical (24 V DC, 110 V AC, 230 V AC versions)
Double Visual-electrical (24 V DC)

High Pressure Filters - Type SFZ

Version - right

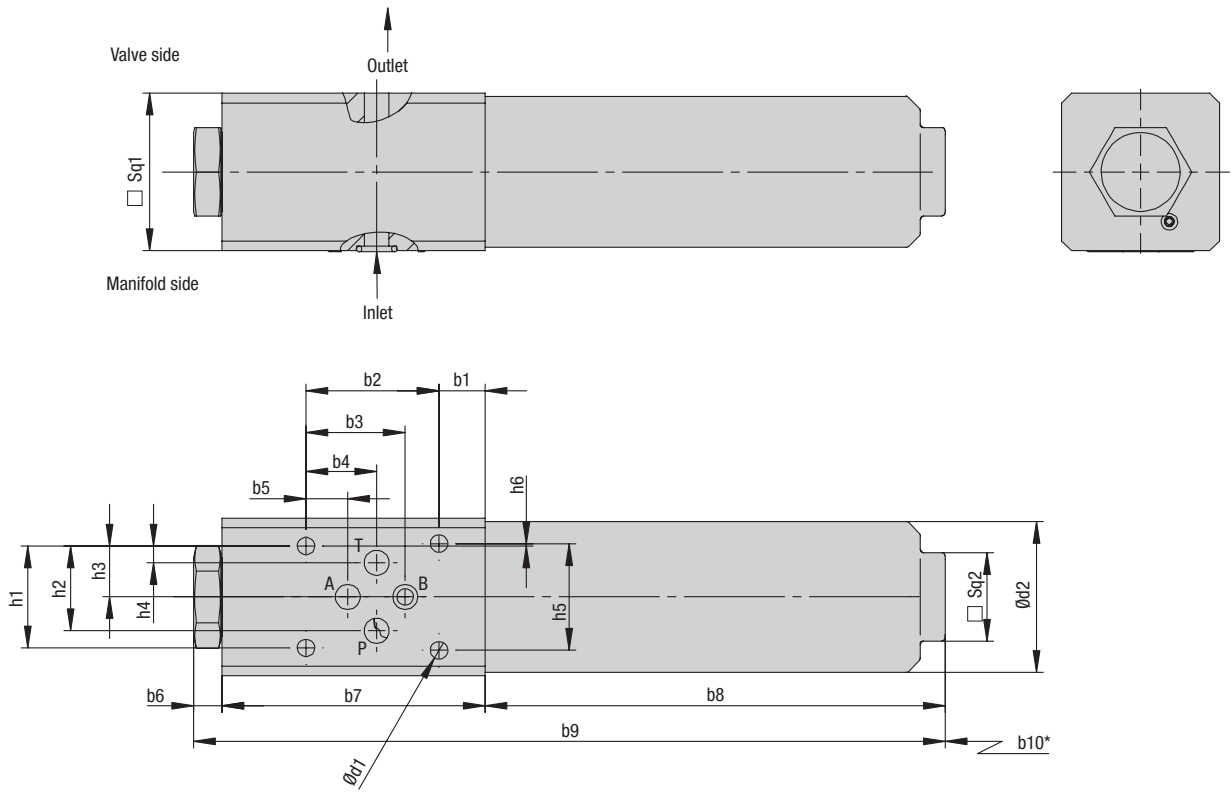

Version - left

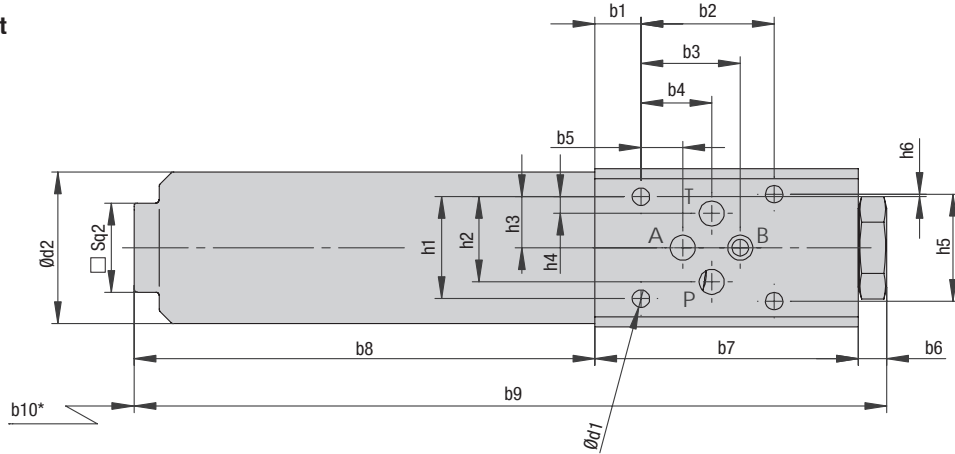

Symbol for hydraulic systems SFZ-008

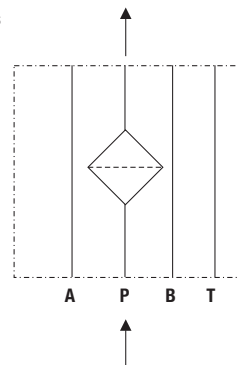

* recommended space for element change

C

High Pressure Filters ▪ Type SFZ

Dimensions (mm/in)	Filter Size SFZ SFZ-008
b1	14
	.55
b2	40,5
	1.59
b3	30,2
	1.19
b4	21,5
	.85
b5	12,7
	.50
b6	9
	.35
b7	80
	3.15
b8	140
	5.51
b9	229
	9.02
b10	50
	1.97
d1	5,3
	.21
d2	46
	1.81
h1	31
	1.22
h2	25,8
	1.02
h3	15,5
	.61
h4	5,1
	.20
h5	32,5
	1.28
h6	0,75
	.03
Sq1	48
	1.89
Sq2	27
	1.06

High Pressure Filter Housings / Complete Filters ■ Type SFZ

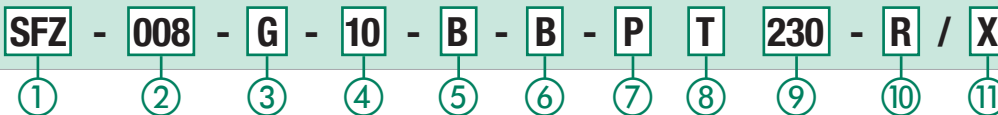

① Type

High Pressure Filter for sandwich plate mounting **SFZ**

② Group

Flow **Size**
30 l/min / 8 US GPM **008**

Note: Exact flow will depend on the selected filter element.

③ Filter Material

Please note that the filter element is not protected by an internal bypass. Please be sure that the hydraulic system is designed with the sufficient means to protect the element.

Material	max. Δp*collapse	Micron ratings available	Code
Without filter element	-	-	0
Inorg. glass fibre	25 bar / 363 PSI	3, 5, 10, 20	G
Inorg. glass fibre	210 bar / 3045 PSI		H
Stainless fibre	210 bar / 3045 PSI		M
Stainless mesh	30 bar / 435 PSI	25, 50, 100, 200	S

Note: * Collapse/burst resistance as per ISO 2941.

④ Micron Rating

3 µm	03
5 µm	05
10 µm	10
20 µm	20
25 µm	25
50 µm	50
100 µm	100
200 µm	200

Note: Other micron ratings on request.

⑤ Sealing Material

NBR (Buna-N®)	B
FKM (Viton®)	V
EPDM	E

Note: Other sealing materials on request.

⑥ Connection Size

Connection Size	Group	Code
	008	
Nominal Bore	NG6* (Ref.: D03)	B

* ISO 4401-03-02-0-05 / DIN 24340-A6 / Cetop R 35 H

⑦ Clogging Indicator

Without clogging indicator	0
Visual, with automatic reset	A
Visual, with manual reset	V
Electrical	E
Electrical, Deutsch plug	ED
Visual-electrical	P
Double Visual-electrical	D024

⑧ Thermostop

Without thermostop	none
With thermostop	T

⑨ Voltage (only for Code P)

24 V DC	024
110 V AC	110
230 V AC	230

⑩ Design

Version right	R
Version left	L

⑪ Design Code

Only for information	X
----------------------	----------

Filter Elements ■ Type SE



① Type

Filter Element Series **SE**

② Group

According to filter housing

③ Filter Material

Please note that the filter element is not protected by an internal bypass. Please be sure that the hydraulic system is designed with the sufficient means to protect the element.

Material	max. Δp*collapse	Micron ratings available	Code
Inorg. glass fibre	25 bar / 363 PSI	3, 5, 10, 20	G
Inorg. glass fibre	210 bar / 3045 PSI		H
Stainless fibre	210 bar / 3045 PSI		M
Stainless mesh	30 bar / 435 PSI	25, 50, 100, 200	S

* Collapse/burst resistance as per ISO 2941.

④ Micron Rating

3 µm	03
5 µm	05
10 µm	10
20 µm	20
25 µm	25
50 µm	50
100 µm	100
200 µm	200

Note: Other micron ratings on request.

⑤ Sealing Material

NBR (Buna-N®)	B
FKM (Viton®)	V
EPDM	E

Note: Other sealing materials on request.

⑥ Design Code

Only for information	X
----------------------	----------

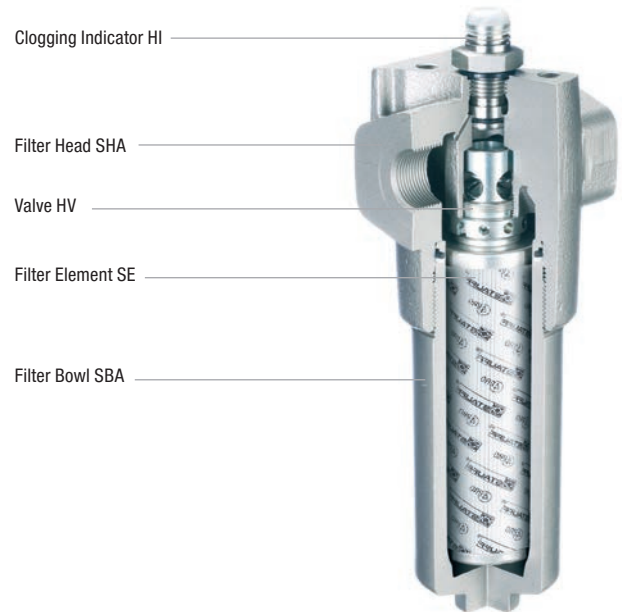
Medium Pressure Filters ■ Type SFA

C
Product Description

STAUFF SFA series Medium Pressure Filters are designed for in-line hydraulic applications with a maximum operating pressure of 160 bar / 2320 PSI. Used together with STAUFF SE series Filter Elements, a high efficiency of contamination removal is assured. The dirt-hold capacity of the elements ensures long service life, and as a result, reduced maintenance costs.

Technical Data
Construction

- Designed for in-line assembly, with threaded mounting holes on top of the head.

Materials

- Filter head: Cast Aluminium
- Filter bowl: Aluminium
- O-rings: NBR (Buna-N®)
FKM (Viton®)
EPDM (Ethylene-Propylene-Diene-Monomer-Rubber)
- Support ring: PTFE (Polytetrafluoroethylene)

Port Connections

- BSP
- NPT
- SAE O-ring thread
- SAE 3000 PSI (Code 61) flange

Operating Pressure

- SFA-014/030: Max. 160 bar / 2320 PSI
Max. 190 bar / 2755 PSI (according to ANSI T2.6.1. R2-2001)
- SFA-045/070: Max. 150 bar / 2175 PSI
Max. 171 bar / 2480 PSI (according to ANSI T2.6.1. R2-2001)

Burst Pressure

- Min. 480 bar / 6960 PSI

Temperature Range

- -20 °C ... +100 °C / -44 °F ... +212 °F
(Short term up to +110 °C / +230 °F)

Filter Elements

- Specifications see page 52

Media Compatibility

- Mineral oils, other fluids on request

Options and Accessories
Valves

- Bypass valve: Allows unfiltered oil to bypass the contaminated element once the opening pressure has been reached, a differential pressure of $6^{+0.5}$ bar / $87^{+7.25}$ PSI Δp is the standard setting. Other settings available upon request.
- Reverse flow valve: Allows reverse flow through the filter head without backflushing the element.
- Non-return valve: Prevents draining of the delivery line during element change.
- Multi-function valve: Opening pressure $6^{+0.5}$ bar / $87^{+7.25}$ PSI
Bypass, reverse flow capability and non-return valve combined in one valve.

Clogging Indicators

- Standard actuating pressure: $5_{-0.5}$ bar / $72.5_{-7.25}$ PSI Δp
Other actuating pressure settings are available upon request.
- Available indicators: Visual
Electrical
Visual-electrical (24 V DC, 110 V AC, 230 V AC versions)
Double Visual-electrical (24 V DC)

Medium Pressure Filters - Type SFA

G

SFA-014...070

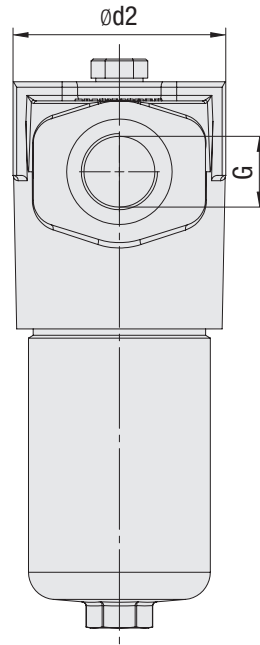
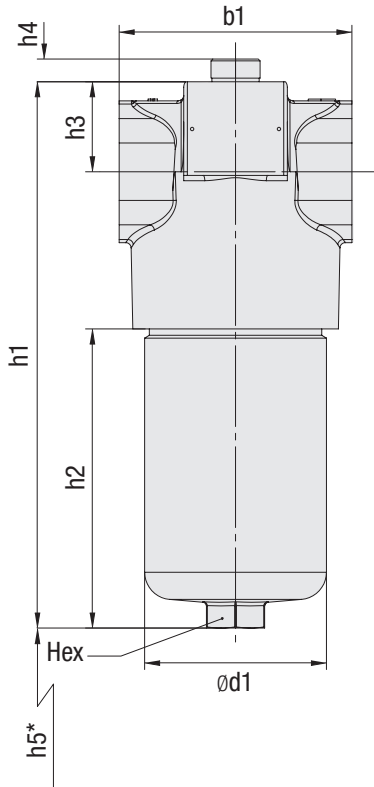

Threaded connection

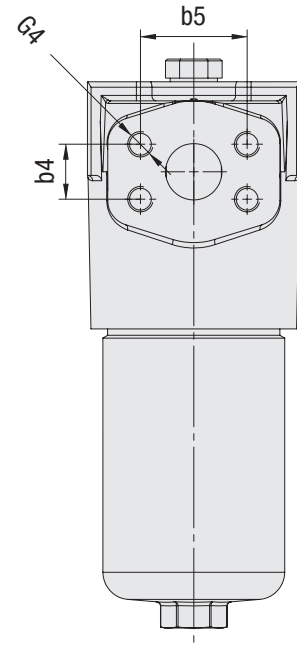

Flange connection

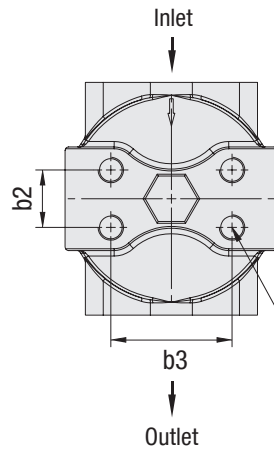

G2: for BSP threads and metric flanges
 G3: for NPT- and SAE-threads and for UNC-flanges

* recommended space for element change

Medium Pressure Filters ■ Type SFA

Thread Connection G	Filter Size SFA			
	014	030	045	070
BSP	3/4	3/4	1-1/4	1-1/4
NPT	3/4	3/4	1-1/4	1-1/4
SAE O-ring Thread	1-1/6-12	1-1/6-12	1-5/8-12	1-5/8-12
SAE Flange 3000 PSI	3/4	3/4	1-1/4	1-1/4
Weight (kg/lbs)	2,1	2,54	4,6	5,3
	4,7	5,6	10,2	11,8

Dimensions (mm/in)	Filter Size SFA				
	014	030	045	070	
b1	92	92	128	128	
	3.62	3.62	5.04	5.04	
d1	72	72	100	100	
	2.83	2.83	3.93	3.93	
d2	86	86	117	117	
	3.39	3.39	4.61	4.61	
h1	187,5	255	241,5	301	
	7.38	10.04	9.51	11.85	
h2	78	145,5	105	164,5	
	3.07	5.73	4.13	6.46	
h3	40	40	49,5	49,5	
	1.58	1.58	1.95	1.95	
h4	12,5	12,5	12,5	12,5	
	.49	.49	.49	.49	
h5	rec.*	100	170	140	200
		3.94	6.69	5.51	7.87
	min.*	85	85	120	120
		3.35	3.35	4.72	4.72
Hex	27	27	32	32	
	1.05	1.05	1.25	1.25	
Dimensions SAE Flange 3000 PSI	b4	22,3	22,3	30,2	30,2
		.88	.88	1.19	1.19
	b5	47,6	47,6	58,7	58,7
		1.87	1.87	2.32	2.32
	G4	M10 x 15 or	M10 x 15 or	M10 x 18 or	M10 x 18 or
		3/8-16 UNC	3/8-16 UNC	7/16-14 UNC	7/16-14 UNC

Reference: rec.*: Recommended | min.*: Minimum

Dimensions (mm/in)	Filter Size SFA				
	014	030	045	070	
r	b2	23,8	23,8	31,6	31,6
		.94	.94	1.24	1.24
	b3	50,8	50,8	66,7	66,7
		2.00	2.00	2.63	2.63
	G2	M10 x 15	M10 x 15	M14 x 17	M14 x 17
	G3	3/8-16 UNC x .59	3/8-16 UNC x .59	1/2-13 UNC x .59	1/2-13 UNC x .59

Medium Pressure Filter Housings / Complete Filters ■ Type SFA

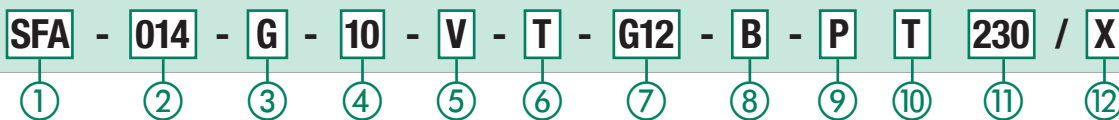

① Type

Medium Pressure Filter **SFA**

② Group

Flow	Size
60 l/min / 14 US GPM	014
110 l/min / 30 US GPM	030
160 l/min / 45 US GPM	045
240 l/min / 70 US GPM	070

Note: Exact flow will depend on the selected filter element.
For technical data please see pages 57 / 58.

③ Filter Material

Material	max. Δp*collapse	Micron ratings available	Code
Without filter element	-	-	0
Inorg. glass fibre	25 bar / 363 PSI	3, 5, 10, 20	G
Inorg. glass fibre	210 bar / 3045 PSI		H
Stainless fibre	210 bar / 3045 PSI		A
Stainless mesh	30 bar / 435 PSI	25, 50, 100, 200	S

Note: * Collapse/burst resistance as per ISO 2941.

④ Micron Rating

3 µm	03
5 µm	05
10 µm	10
20 µm	20
25 µm	25
50 µm	50
100 µm	100
200 µm	200

Note: Other micron ratings on request.

⑤ Sealing Material

NBR (Buna-N®)	B
FKM (Viton®)	V
EPDM	E

Note: Other sealing materials on request.

⑥ Connection Flange

Type T	T
--------	----------

⑦ Connection Style

Connection Style	Thread Style	Group		Code		Code
		014	030	045	070	
BSP	-	3/4		G12	1-1/4	G20
BSP	-	1		G16	1-1/2	G24
NPT	-	3/4		N12	1-1/4	N20
SAE O-ring Thread	-	1-1/16-12		U12	1-5/8-12	U20
SAE Flange 3000 PSI	metric	3/4		C312M	1-1/4	C320M
SAE Flange 3000 PSI	UNC	3/4		C312U	1-1/4	C320U
SAE Flange 3000 PSI	metric	1		C316M	-	-
SAE Flange 3000 PSI	UNC	1		C316U	-	-

Note: Other port connections on request. Bold types identify preferred connection styles.

⑧ Valve

Without valve	0
Bypass valve	B
Reverse flow valve	R
Non-return valve	N
Multi-function valve	M

⑨ Clogging Indicator

Without clogging indicator	0
Visual, with automatic reset	A
Visual, with manual reset	V
Electrical	E
Electrical, Deutsch plug	ED
Visual-electrical	P
Double Visual-electrical	D024

⑩ Thermostop

Without thermostop	none
With thermostop	T

⑪ Voltage (only for Code P)

24 V DC	024
110 V AC	110
230 V AC	230

⑫ Design Code

Only for information	X
----------------------	----------

Filter Elements ■ Type SE

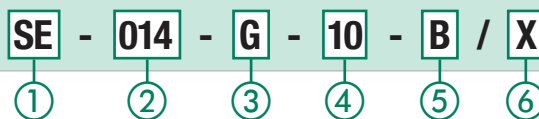

① Type

Filter Element Series **SE**

② Group

According to filter housing

③ Filter Material

Material	max. Δp*collapse	Micron ratings available	Code
Inorganic glass fibre	25 bar / 363 PSI	3, 5, 10, 20	G
Inorganic glass fibre	210 bar / 3045 PSI		H
Stainless fibre	210 bar / 3045 PSI		A
Stainless mesh	30 bar / 435 PSI	25, 50, 100, 200	S

Note: Collapse/burst resistance as per ISO 2941.

④ Micron Rating

3 µm	03
5 µm	05
10 µm	10
20 µm	20
25 µm	25
50 µm	50
100 µm	100
200 µm	200

Note: Other micron ratings on request.

⑤ Sealing Material

NBR (Buna-N®)	B
FKM (Viton®)	V
EPDM	E

Note: Other sealing materials on request.

⑥ Design Code

Only for information	X
----------------------	----------

Product Description (not available for SFZ)

The optional valves are fitted as an insert in the filter head and incorporate the spigot on which the element seals. The valve is selected to suit the filter application.

HVO **Non-bypass standard insert** without any valve function.
Element collapse rating should be higher than the system pressure

HVB **Bypass valve** which allows oil to bypass the element when the differential pressure across the element reaches $6^{+0.5}$ bar / $87^{+7.25}$ PSI. (Other pressure settings available on request). The opening pressure should be higher than the Δp setting of an optional clogging indicator. Low collapse 30 bar / 435 PSI Δp elements are normally used with this valve.

HVR **Reverse flow valve** is used in systems where there is flow in reverse through the filter. It allows reverse flow without backflushing the element but does not filter in the reverse direction. Element collapse rating should be higher than the system pressure.

HVN **Non-return valve**
This valve prevents the oil in the delivery line from draining out while the filter is being serviced. Because there is no bypass, the element collapse rating should be higher than system pressure.

HVM **Multi-function valve**
This valve combines the bypass, the reverse flow and the non-return functions in one unit. The by-pass opening pressure is $6^{+0.5}$ bar / $87^{+7.25}$ PSI Δp with other opening pressures available on request. The opening pressure should be higher than the Δp setting of an optional clogging indicator. Low collapse 30 bar / 435 PSI Δp elements are normally used with this valve.

Order Code

VALVE - **HVB** - **014/030** / **X**

①

②

③

④

① Type

Valve for Pressure Filters	VALVE
----------------------------	--------------

② Valve Type

Non-bypass standard insert without any valve	HVO
Bypass valve	HVB
Reverse flow valve	HVR
Non-return valve	HVN
Multi-function valve	HVM

③ Filter Group

For filter size 014/030	014/030
For filter size 045/070/125	045/070
For filter size 090/160/250/300	090/160

④ Design Code

Only for information	X
----------------------	----------

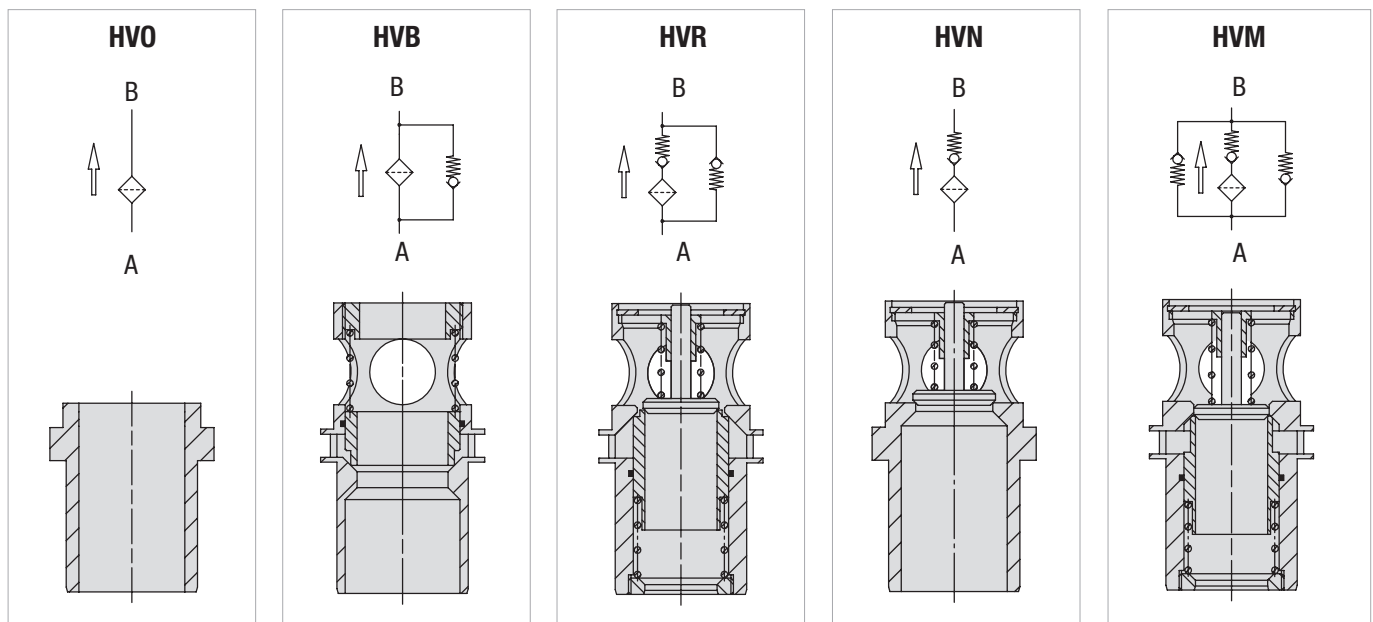

Flow characteristics of the valves see page 56.

Note:

For high dynamic applications and applications with very high cycle numbers (pressure and volume flow) please contact STAUFF.

The service life of HVM, HVR valves may be affected by high flows or fast/frequent load changes.

For more information, please contact STAUFF.

Clogging Indicators

Product Description

STAUFF Pressure Filters have a wide range of clogging indicators available. If no indicator is specified, the port is sealed by a plug (HI-O). The clogging indicators are actuated by the differential pressure (Δp) across the element. The special piston design minimizes the effects of peak pressures in the system. An optional thermal lockout (thermo-stop) is available to prevent false indication under cold start conditions. Fluid temperature have to be at least +20 °C / +68 °F for the indicator to function.

Plug Type HI-O and visual Clogging Indicators Type HI-A and HI-V

HI-O

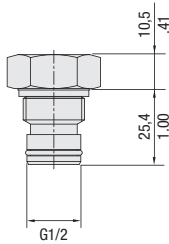

Technical Data

Materials

- Body: Stainless Steel

The visual clogging indicators are available in the following configurations:

- Manual reset: The indicator continues to display the clogged signal even through the Δp may have fallen. Pressing the plastic cover down will reset the indicator.
- Automatic reset: The clogged signal will disappear when the Δp drops below the setting for the indicator.

Order Code

HI - A - T - B - B5.0 / X

① ② ③ ④ ⑤ ⑥

HI-A / HI-V

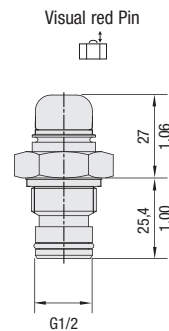
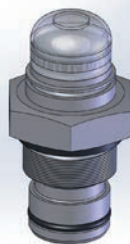

① Type

Clogging Indicator for Pressure Filters **HI**

② Indicator Type

Plug **0**
 Visual, automatic reset **A**
 Visual, manual reset **V**

③ Thermostop

Without thermostop **none**
 With thermostop **T**

③ Sealing Material

NBR (Buna-N®) **B**
 FKM (Viton®) **V**
 EPDM **E**

④ Differential Pressure Setting (only HI-A and HI-V)

1,72 bar / 25 PSI **B1.7**
 2,0 bar / 29 PSI **B2.0**
 2,5 bar / 36.3 PSI **B2.5**
 3,0 bar / 43.5 PSI **B3.0**
5,0 bar / 72.5 PSI (standard option) B5.0
 7,0 bar / 101.5 PSI **B7.0**

Note: Bold types identify standard option

⑤ Design Code

Only for information **X**

Electrical and Visual-electrical Clogging Indicators Type HI-E, HI-ED and HI-P

HI-E

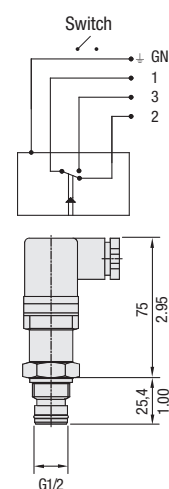
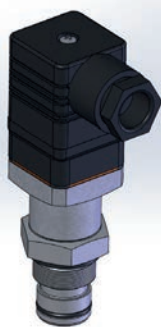

HI-ED

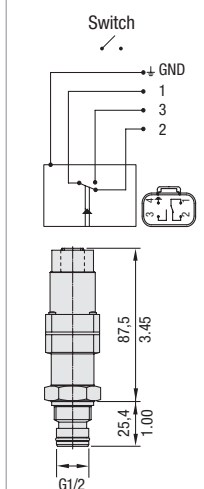
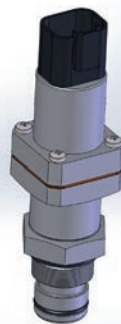

HI-P

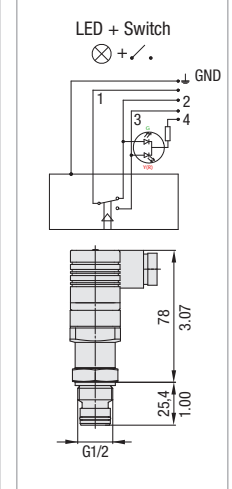
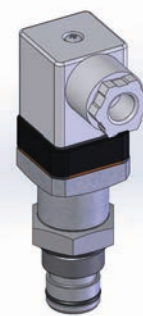

Continued on page 55.

Dimensional drawings: All dimensions in mm/in.

Clogging Indicators

Technical Data

Materials

- Body: Stainless Steel

Alarm outputs

- HI-E: electrical
- HI-ED: electrical
- HI-P: visual-electrical (LED red and green)

Electrical

- Plug according to DIN-EN 175301-803 A (DIN 43650-A).
- Screwed cable gland PG11
- Protection rating (DIN 40050) IP65
- Both NO and NC contacts are available in the switch, rated capacity: see chart below
- Deutsch plug

Note: The customer / user carries the responsibility for the electrical connection.

Rated Capacity

Voltage V	Resistive Load A	Inductive Load A
110 V AC	5A	3A
230 V AC	3A	2A
24 V DC	4A	3A
Max. Load		
24 V AC ± 10%	1A	

High voltage peaks occur when inductive loads are switched off. Protective circuitry should be employed to reduce contact burnout.

Order Code

HI - P T 230 - B - B5.0 / X

① Type

Clogging Indicator for Pressure Filters **HI**

② Indicator Type

electrical **E**
 Electrical, Deutsch plug **ED**
 Visual-electrical **P**

③ Thermostop

Without thermostop **none**
 With thermostop **T**

④ Voltage (only for Code P)

24 V DC **024**
 110 V AC **110**
 230 V AC **230**

⑤ Sealing Material

NBR (Buna-N®) **B**
 FKM (Viton®) **V**
 EPDM **E**

⑥ Differential Pressure Setting

1,72 bar / 25 PSI **B1.7**
 2,0 bar / 29 PSI **B2.0**
 2,5 bar / 36.3 PSI **B2.5**
 3,0 bar / 43.5 PSI **B3.0**
5,0 bar / 72.5 PSI (standard option) B5.0
 7,0 bar / 101.5 PSI **B7.0**

Note: Bold types identify standard option

⑦ Design Code

Only for information **X**

Product Description

The differential pressure indicator HI-D024 is a microprocessor controlled pressure switch with two alarm outputs for pre-alarm and shut-off. It is used to monitor the capacity of oil filters in oil-circulating systems. For this purpose, a microprocessor-controlled pressure sensor observes the dynamic pressure in front of the filter element or the differential pressure at the filter element. The pressure increases depending on the cumulative clogging of the filter. To avoid false alarms due to high viscosity during start-up, the device is equipped with a temperature control and time delay function.

Technical Data

Connection Thread

- G1/2

Operating Pressure

- Max. 420 bar / 6000 PSI

Temperature Range

- 20 °C ... +80 °C / -4 °F ... +176 °F
- ready for operation > 20 °C / 68 °F

Materials

- Body: Brass
- Sealing Material: NBR (Buna-N®)

Protection Rating

- IP 67

Rated Capacity

- Max. 0,2 A, 24 V DC

Operating Voltage

- 24 V DC

Alarm outputs (electrical)

- 3,8 +10% bar / 55.1 +/- 10% PSI
 $\Delta p = 75\%$ (Pin 4)
- 5 +10% bar / 72.5 +/- 10% PSI
 $\Delta p = 100\%$ (Pin 2)

Alarm outputs (visual)

Range (%FS)	Color	T>T* (Thermo-stop)
0-50	green	
50-75	yellow	
75-100	orange	
100	red (flashing)	
		T<T* (Thermo-stop)
0-100	blue	

T = Temperature
 T* = 20 °C / 68 °F

Order Code

HI-D-024-B-B5.0

① Type

Clogging Indicator for Pressure Filters

HI-D-024-B-B5.0

Dimensional drawings: All dimensions in mm/in.

Double Visual-electrical Clogging Indicator

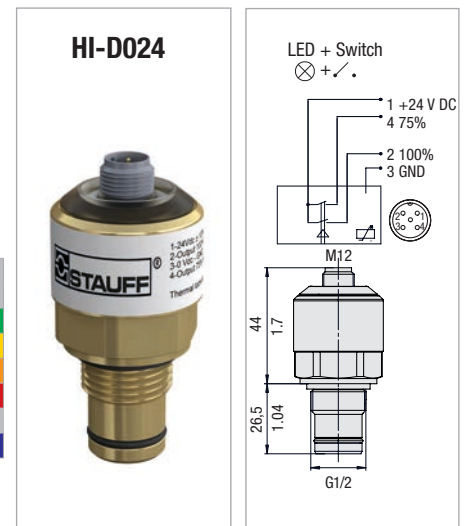

High and Medium Pressure Filters - Type SF / SF-TM / SFZ / SFA

The following characteristics are valid for mineral oils with a density of 0,85 kg/dm³ and the kinematic viscosity of 30 mm²/s (30 cSt). The characteristics have been determined in accordance to ISO 3968. Multipass filter ratings have been obtained in accordance to ISO 16889. Contact STAUFF for details.

C

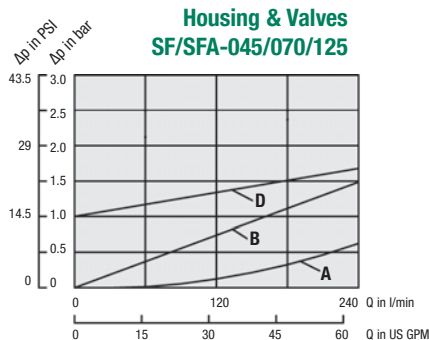
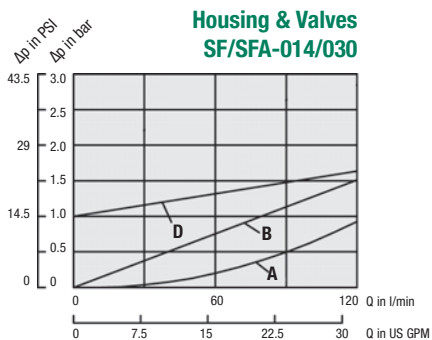

Valve Configuration	Flow direction	Curve
Housing with HVO/IO or HVB/IB	Inlet → Outlet	A
HVM, HVR, HVN	Inlet → Outlet	B
HVM, HVR Reverse mode	Outlet → Inlet	D

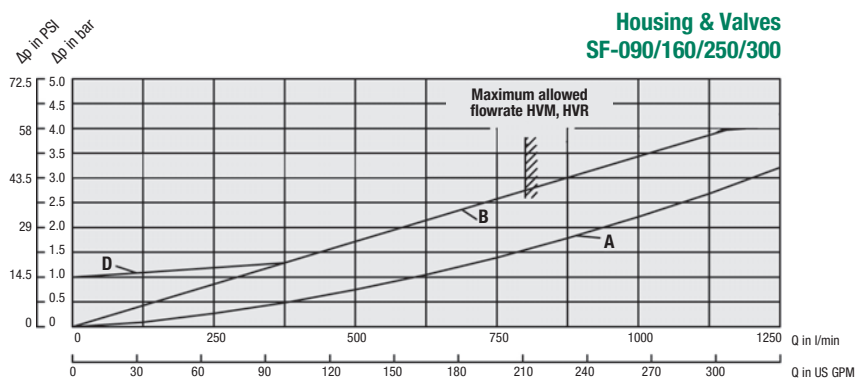

Note:
For high dynamic applications and applications with very high cycle numbers (pressure and volume flow) please contact STAUFF.

The service life of HVM, HVR valves may be affected by high flows or fast/frequent load changes.
For more information, please contact STAUFF.

High and Medium Pressure Filters - Type SF / SF-TM / SFZ / SFA

The following characteristics are valid for mineral oils with a density of 0,85 kg/dm³ and the kinematic viscosity of 30 mm²/s (30 cSt). The characteristics have been determined in accordance to ISO 3968. Multipass filter ratings have been obtained in accordance to ISO 16889. Contact STAUFF for details.

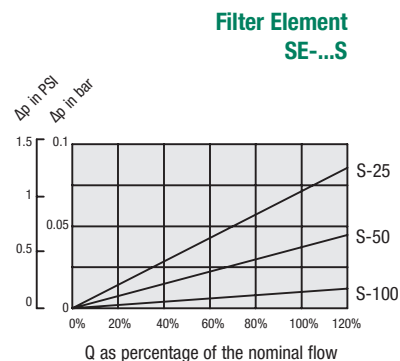
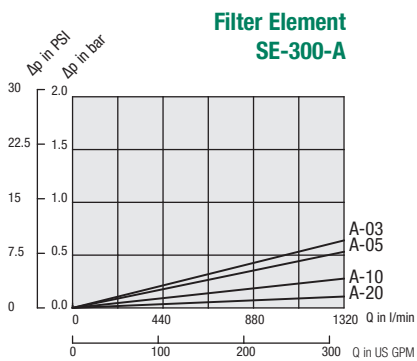
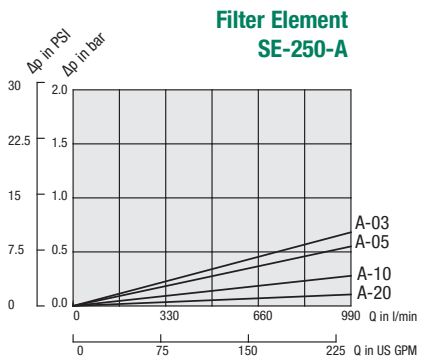
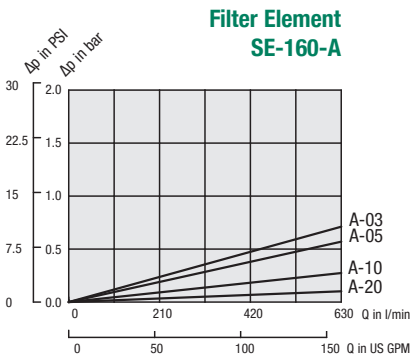
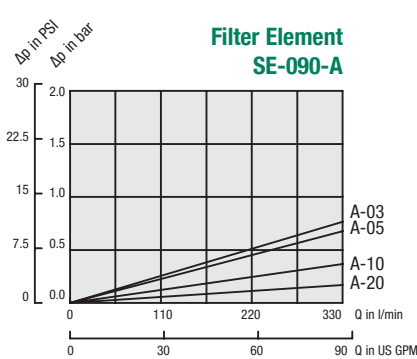
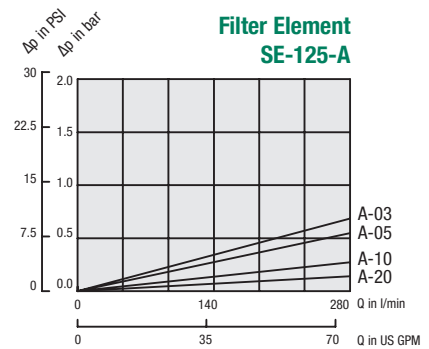
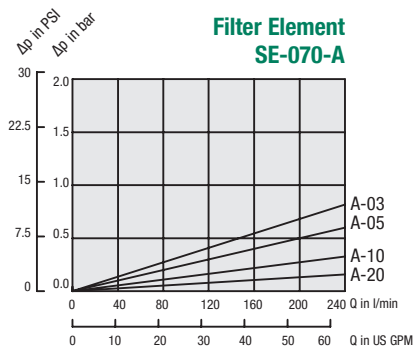
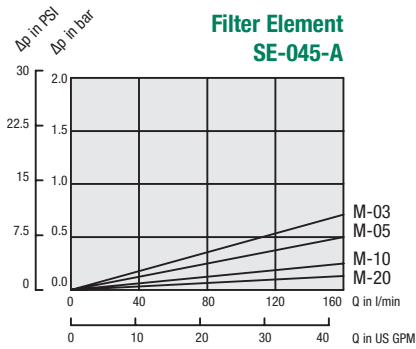
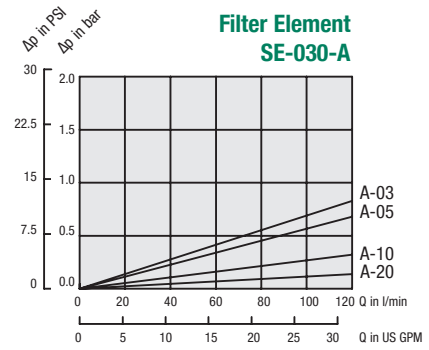
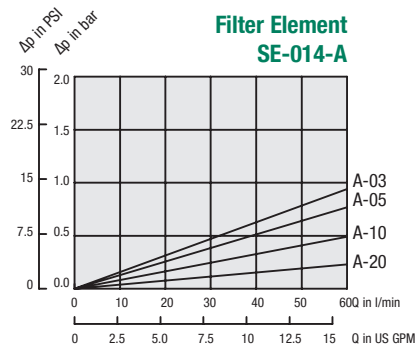
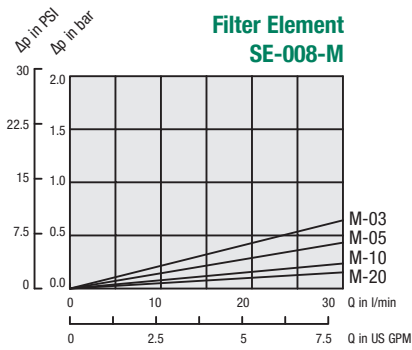

C

High and Medium Pressure Filters - Type SF / SF-TM / SFZ / SFA

The following characteristics are valid for mineral oils with a density of 0,85 kg/dm³ and the kinematic viscosity of 30 mm²/s (30 cst). The characteristics have been determined in accordance to ISO 3968. Multipass filter ratings have been obtained in accordance to ISO 16889. Contact STAUFF for details.

C

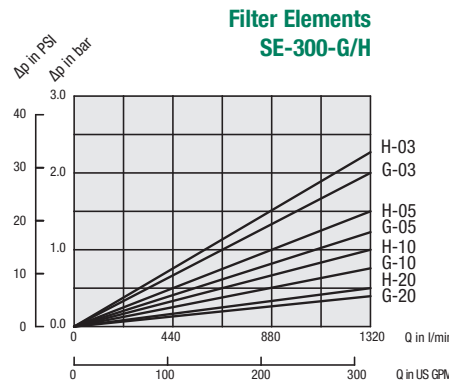
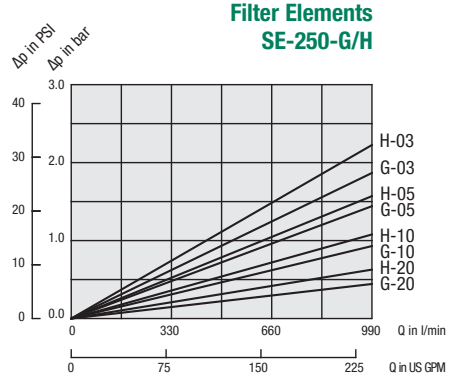
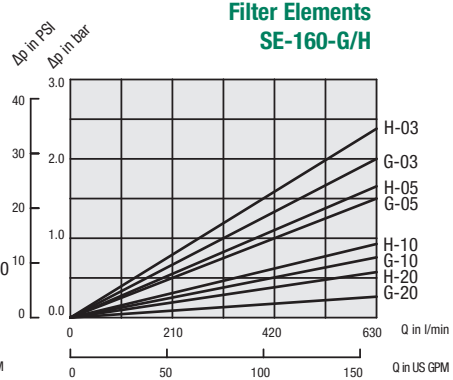
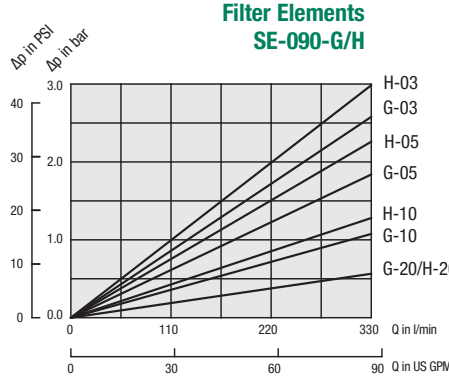
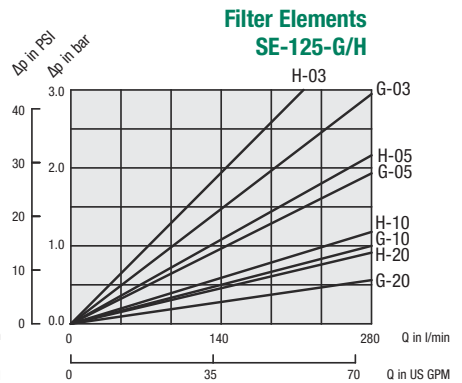
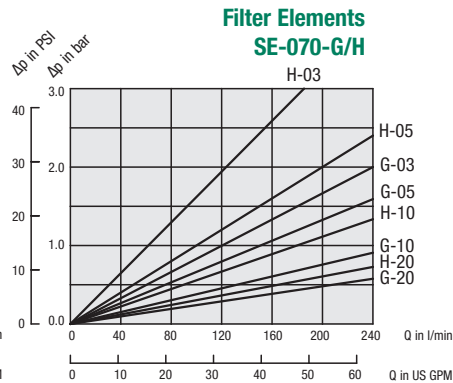
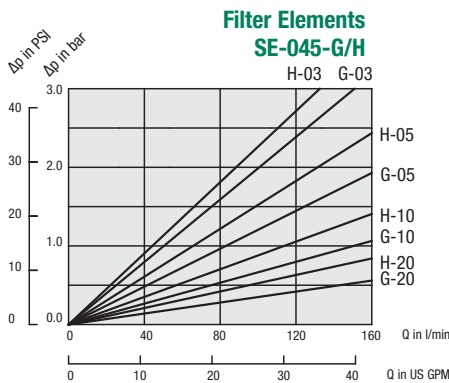
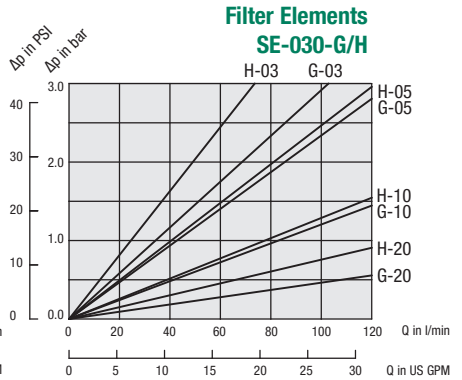
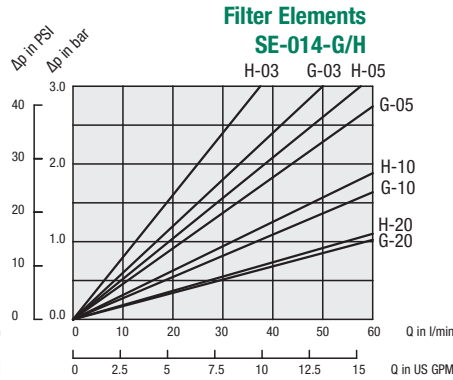
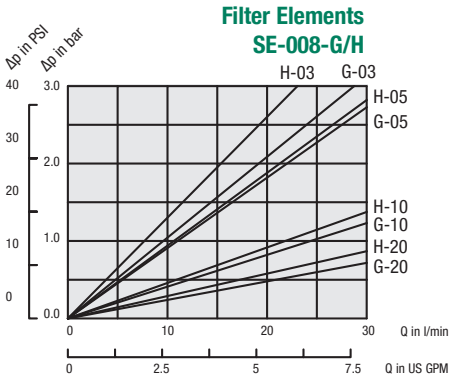

Medium Pressure Filters ▪ Type SMPF



C

Product Description

STAUFF SMPF Medium Pressure Filters are designed for in-line hydraulic applications with a maximum operating pressure of 110 bar / 1600 PSI. Used together with STAUFF Filter Elements, a high efficiency of contamination removal is assured.

Technical Data
Construction

- In-line assembly

Materials

- Filter head: Aluminium Alloy
- Filter bowl: Aluminium Alloy
- Sealings: NBR (Buna-N®)

Port Connections

- BSP
- SAE O-ring thread

Flow Rating

- Up to 90 l/min / 25 US GPM

Operating Pressure

- Max. 110 bar / 1600 PSI

Burst Pressure

- 300 bar / 4350 PSI

Temperature Range

- -25 °C ... +110 °C / -13 °F ... +230 °F

Filter Elements

- Specifications see page 62

Media Compatibility

- Mineral oils, other fluids on request

Options and Accessories
Valve

- Bypass valve: Allows unfiltered oil to bypass the contaminated element once the opening pressure has been reached
6 bar / 87 PSI \pm 10% is the standard actuating pressure

Clogging Indicators

- Standard actuating pressure: 5 bar / 72.5 PSI \pm 10%
- Available indicators: Visual
Visual-electrical

Medium Pressure Filters - Type SMPF

C

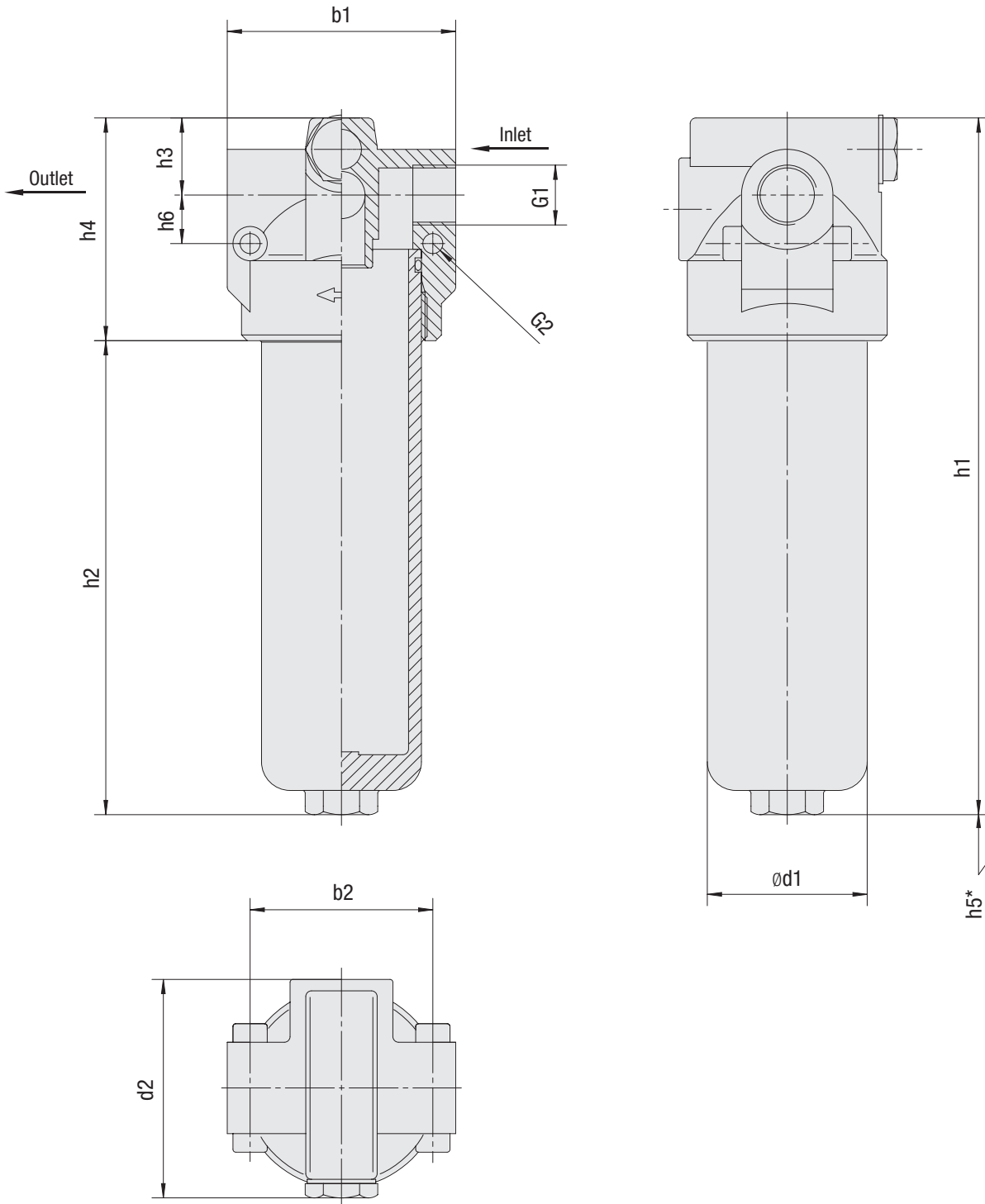

* recommended space for element change

Medium Pressure Filters ▪ Type SMPF

Thread Connection G1	Filter Size SMPF	
	015	025
Nominal Flow (l/min / US GPM)	60	90
	15	25
BSP	1/2	1/2
SAE O-ring thread	3/4-16	3/4-16
Weight (kg/lb)	0,95	1,25
	2.09	2.76

Dimensions (mm/in)	Filter Size SMPF	
	015	025
b1	80	80
	3.15	3.15
b2	64	64
	2.52	2.52
d1	56	56
	2.20	2.20
d2	76,5	76,5
	3.01	3.01
h1	157	244
	6.18	9.61
h2	79	166
	3.11	6.54
h3	27	27
	1.06	1.06
h4	78	78
	3.07	3.07
h5	60	60
	2.36	2.36
h6	17	17
	.67	.67
G2	7	7
	.28	.28

Medium Pressure Filter Housings / Complete Filters ■ Type SMPF

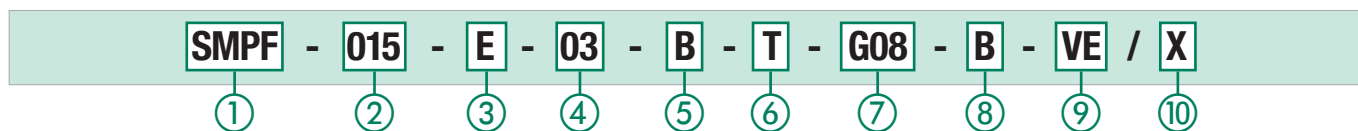

① Type

Medium Pressure Filter **SMPF**

② Group

Flow	Size
60 l/min / 15 US GPM	015
90 l/min / 25 US GPM	025

Note: Exact flow will depend on filter element selected
For technical data please see page 64.

③ Filter Material

Material	Max. Δp*collapse	Micron ratings available	Code
Without filter element	-	-	0
Inorg. glass fibre	20 bar / 290 PSI	03,05,10,20	E
Stainless mesh	20 bar / 290 PSI	60	S

* Note: Collapse/burst resistance as per ISO 2941.
Other materials on request.

④ Micron Rating

3 μm	03
5 μm	05
10 μm	10
20 μm	20
60 μm	60

Note: Other micron ratings on request.

⑤ Sealing Material

NBR (Buna®) **B**
Note: Other sealing materials on request.

⑥ Mounting Style

In-line **T**

⑦ Connection Style

BSP 1/2 **G08**
SAE O-ring thread 3/4-16 **U08**

⑧ Valve

Without valve **0**
Bypass valve **B**

⑨ Clogging Indicator

Without Clogging Indicator **0**
Visual **V**
Visual-electrical **VE**

⑩ Design Code

Only for information **X**

Filter Elements ■ Type SME

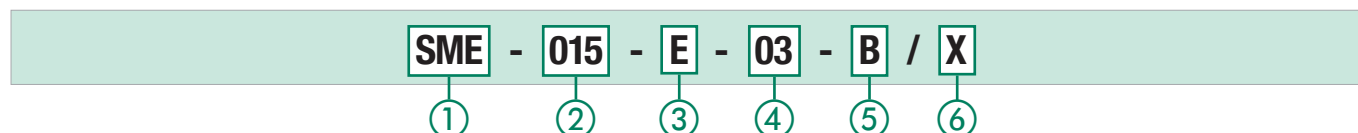

① Type

Filter Element Series **SME**

② Group

According to filter housing

③ Filter Material

Material	Max. Δp*collapse	Micron ratings available	Code
Inorg. glass fibre	20 bar / 290 PSI	03,05,10,20	E
Stainless mesh	20 bar / 290 PSI	60	S

* Note: Collapse/burst resistance as per ISO 2941.
Other materials on request.

④ Micron Rating

3 μm	03
5 μm	05
10 μm	10
20 μm	20
60 μm	60

Note: Other micron ratings on request.

⑤ Sealing Material

NBR (Buna®) **B**
Note: Other sealing materials on request.

⑥ Design Code

Only for information **X**

Medium Pressure Filters - Type SMPF
Visual Clogging Indicator

Part number **HIM-V** is a clogging indicator actuated by the differential pressure across the filter element. The actuating pressure of 5 bar / 72.5 PSI allows the clogged element to be changed before the bypass setting of 6 bar / 87 PSI is reached.

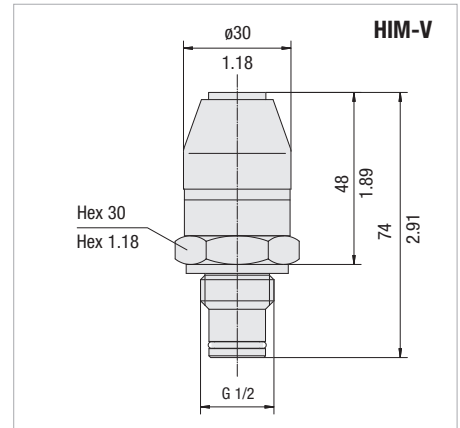
Visual-Electrical Clogging Indicator

Part number **HIM-VE** is used when an electrical signal is needed to indicate when the element needs changing. It is actuated by the differential pressure across the filter element. The actuating pressure of 5 bar / 72.5 PSI allows the clogged element to be changed before the bypass setting of 6 bar / 87 PSI is reached.

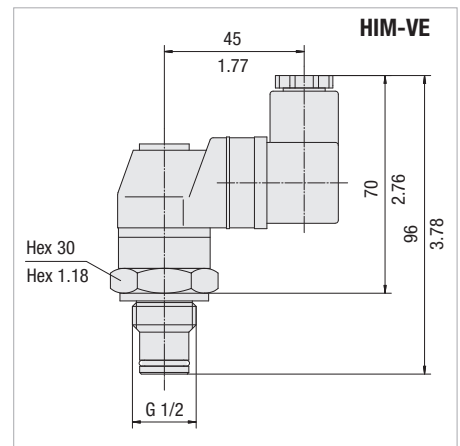

Dimensions in mm / in

HIM-VE Rated Capacity

Voltage V	Resistive Load A	Inductive Load A
125 V AC	5	5
250 V AC	5	5
15 V AC	10	10
30 V DC	5	5
50 V DC	1	1
125 V DC	0.50	0.06

Note: The customer / user carries the responsibility for the electrical connection.

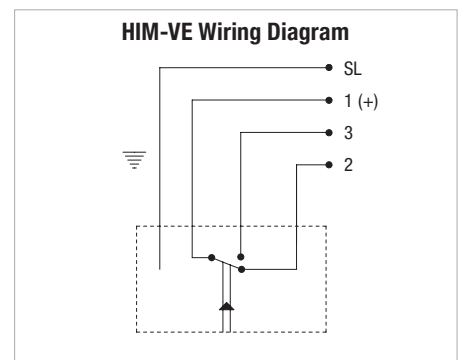
Order Code

HIM -
 V -
 B -
 B5.0 /
 X

①
 ②
 ③
 ④
 ⑤

① Type Clogging Indicator SMPF Series HIM	③ Sealing Material NBR (Buna®) B	⑤ Design Code Only for information X
② Indicator Type Visual V Visual-electrical VE	④ Differential Pressure Setting 5,0 bar / 72.5 PSI B5.0	

Medium Pressure Filters - Type SMPF Flow Characteristics

The following characteristics are valid for mineral oils with a density of 0,85 kg/dm³ and the kinematic viscosity of 30 mm²/s (30 cSt). The characteristics have been determined in accordance to ISO 3968. Multipass filter ratings have been obtained in accordance to ISO 16889. Contact STAUFF for details.

C

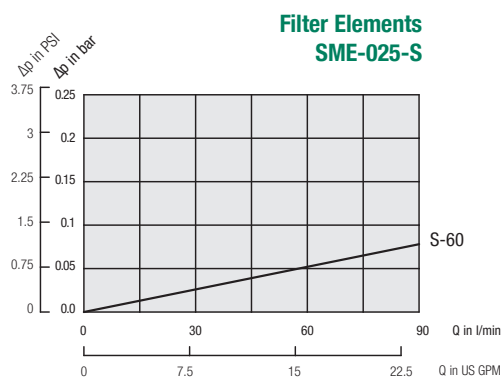
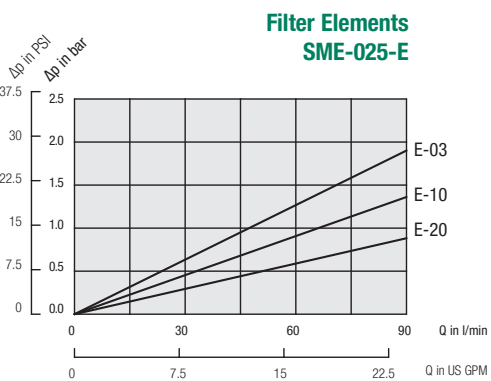
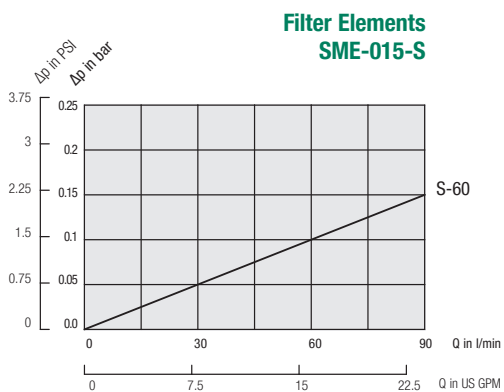
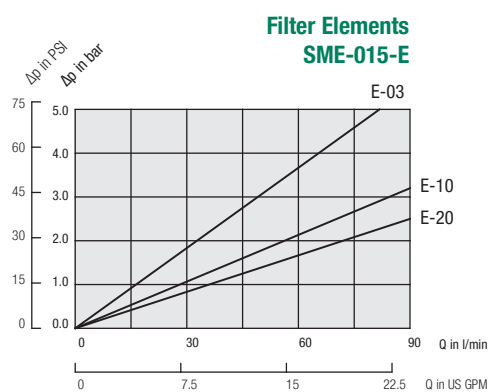
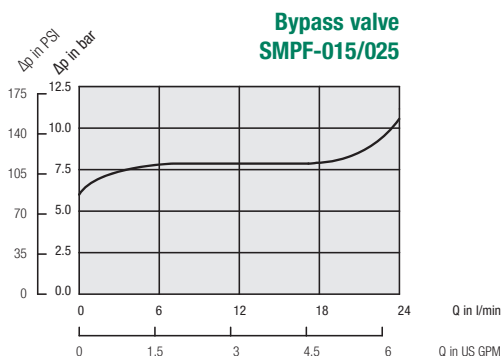
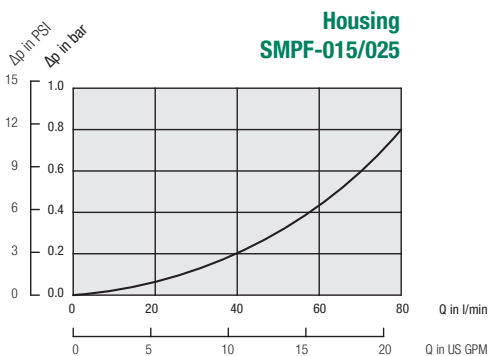

Checklist for the selection of filter housings

Please use the following Checklist as a guideline when preparing an enquiry for the selection of filter housings. Scan or copy the page from the catalogue, print and com-

plete it with as much information as possible, before sending it by email or fax to the closest STAUFF branch office. If possible, please also let us know the quantities required,

and if the enquiry is for a one-time or recurring demand. We look forward to hearing from you, and are always available for consultation, when required.

Information on the fluid in use					
Type of fluid	<input type="text"/>	Brand	<input type="text"/>	ISO designation	
Fluid viscosity	<input type="text"/>	<input type="checkbox"/>	mm ² /sec	<input type="checkbox"/>	cSt
Fluid temperature	<input type="text"/>	°C	<input type="checkbox"/>	°F	<input type="text"/>
			<input type="checkbox"/>	In cold condition	<input type="text"/>
					<input type="checkbox"/>
				In warm condition	
Information on the filter housing					
Position in the hydraulic system	<input type="checkbox"/>	Suction line	<input type="checkbox"/>	Pressure line	<input type="checkbox"/>
				Return line	
Operating pressure	<input type="text"/>	<input type="checkbox"/>	bar	<input type="checkbox"/>	PSI
Nominal flow	<input type="text"/>	<input type="checkbox"/>	l/min	<input type="checkbox"/>	US GPM
Valve	<input type="checkbox"/>	No, not required			
	<input type="checkbox"/>	Yes, the following type:	<input type="checkbox"/>	Bypass valve	<input type="checkbox"/>
			<input type="checkbox"/>	Non-return valve	<input type="checkbox"/>
			<input type="checkbox"/>	Reverse flow valve	<input type="checkbox"/>
			<input type="checkbox"/>	Multi-function valve	
Clogging indicator	<input type="checkbox"/>	No, not required			
	<input type="checkbox"/>	Yes, the following type:	<input type="checkbox"/>	Visual	<input type="checkbox"/>
			<input type="checkbox"/>	Electrical	<input type="checkbox"/>
			<input type="checkbox"/>	Visual-electrical	
Connection type and size	<input type="text"/>				
Sealing material	<input type="checkbox"/>	NBR (Buna®)	<input type="checkbox"/>	FKM (Viton®)	<input type="text"/>
				Other	
Information on the filter element					
Filter media	<input type="checkbox"/>	Inorganic Glass Fibre	<input type="checkbox"/>	Polyester Fibre	<input type="checkbox"/>
			<input type="checkbox"/>	Cellulose Fibre	<input type="checkbox"/>
			<input type="checkbox"/>	Stainless Fibre	<input type="checkbox"/>
			<input type="checkbox"/>	Stainless Mesh	
Micron rating	<input type="text"/>	µm			
Cleanliness level	<input type="text"/>	(to ISO 4406)			
Information on the application	<input type="text"/>				
Information on the ambient conditions	<input type="text"/>				
Additional information and requirements	<input type="text"/>				

C



Overview Return-Line Filters 68

RF / RFA / RFB / RFS / RFS-D / RTF / RTF-N



Return-Line Filters **RF** **69 - 76**
 Max. 16 bar / 232 PSI
 Max. 500 l/min / 130 US GPM

Technical Data / Dimensions 70 - 71

Order Code - Return-Line Filter 72

Order Code - Filter Elements 72

Options - Clogging Indicators 73 - 74

Flow Characteristics 75 - 76



Return-Line Filters **RFA** **77 - 83**
 Max. 25 bar / 365 PSI
 Max. 110 l/min / 30 US GPM

Technical Data / Dimensions 78 - 79

Order Code - Return-Line Filter 80

Order Code - Filter Elements 80

Options - Clogging Indicators 81 - 82

Flow Characteristics 83

Checklist for the selection of filter housings 84



Return-Line Filters **RFB** **85 - 91**
 Max. 10 bar / 145 PSI
 Max. 185 l/min / 52 US GPM







Technical Data / Dimensions 86 - 87

Order Code - Return-Line Filter 88

Order Code - Filter Elements / Air Filter Elements 88

Options - Clogging Indicators 89 - 90

Flow Characteristics 91

	Checklist for the selection of filter housings	92			
	Return-Line Filters Max. 25 bar / 365 PSI Max. 1135 l/min / 300 US GPM	RFS / RFS-D	93 - 102		Return-Line Filters Max. 6,9 bar / 100 psi Max. 379 l/min / 100 US GPM
	Technical Data / Dimensions		94 - 97		Technical Data / Dimensions
	Order Code - Return-Line Filter		98		Order Code - Return-Line Filter
	Order Code - Filter Elements		98		Order Code - Filter Elements
	Options - Clogging Indicators		99 - 100		
	Flow Characteristics		101 - 102		
	Return-Line Filters Max. 6,9 bar / 100 PSI Max. 95 l/min / 25 US GPM	RTF-10/15/25	103 - 106		Return-Line Filters Max. 10 bar / 145 psi Max. 500 l/min / 132 GPM
	Technical Data / Dimensions		104 - 105		Technical Data / Dimensions
	Order Code - Return-Line Filter		106		Order Code - Return-Line Filter
	Order Code - Filter Elements		106		Order Code - Filter Elements
					Flow Characteristics
					RTF
					Options - Clogging Indicators
	Return-Line Filters Max. 6,9 bar / 100 PSI Max. 115 l/min / 30 US GPM	RTF-20	107 - 110		
	Technical Data / Dimensions		108 - 109		
	Order Code - Return-Line Filter		110		
	Order Code - Filter Elements / Air Filter Elements		110		
	Return-Line Filters Max. 6,9 bar / 100 psi Max. 378 l/min / 100 US GPM	RTF-40	111 - 114		
	Technical Data / Dimensions		112 - 113		
	Order Code - Return-Line Filter		114		
	Order Code - Filter Elements		114		

D

Description

STAUFF Return-Line Filters were designed as filters for tank-top mounting, tank-inside mounting or inline mounting. They filter the hydraulic oil before it flows back into the reservoir. This ensures that contamination arising in the components does not get into the tank. Return-Line filters maintain the targeted purity class like Pressure Filters. However, because of their arrangement, they do not fulfil the additional function of a protection filter. In contrast to a Pressure Filter, it only has to withstand low pressure levels.

The practical design of STAUFF Return-Line Filters enables quick assembly as well as easy exchange of the filter elements.

Media Compatibility

- Mineral oils, others on request

Options and Accessories

Valves

- Bypass valve integrated in the filter element (except STAUFF Return-Line Filter RTF)

Clogging Indicators

- On request with visual clogging indicator or electrical clogging switch
- Others on request



Type RF

- Filter bowl with option of thread connection (e.g. STAUFF Diffuser SRV) or leakage oil connection
- Operating pressure: max. 16 bar / 232 PSI
- Nominal flow rate: max. 500 l/min / 130 US GPM
- Materials: Glass Fibre reinforced Polyamide / Aluminium
- Connections: BSP, NPT, SAE thread or SAE flange (ISO 6162-1)



Type RFA

- Filter bowl with option of thread connection (e.g. STAUFF Diffuser SRV) or leakage oil connection
- Operating pressure: max. 25 bar / 365 PSI
- Nominal flow rate: max. 110 l/min / 30 US GPM
- Materials: Filter housing: Aluminium
- Connection: SAE thread



Type RFB

- Low weight and compact design
- Filter bowl with option of thread connection
- Filter head with option of integrated air filter
- Operating pressure: max. 10 bar / 145 PSI
- Nominal flow rate: max. 185 l/min / 52 US GPM
- Materials: Filter head: Aluminium, Filter bowl: PA
- Connections: BSP, NPT, SAE thread



Type RFS and RFS-D

- Robust design, suitable for high flow rates
- Filter bowl with option of BSP or SAE flange
- Operating pressure: max. 25 bar / 365 PSI
- Nominal flow rate: max. 1135 l/min / 300 US GPM
- Materials: Filter head and bowl: Steel
- Connections: BSP or SAE flange (ISO 6162-1)



Type RTF

- Filter bowl is designed to return the oil beneath the surface thus preventing entrainment of air
- Filter head with option of integrated air filter
- Operating pressure: max. 10 bar / 49 PSI
- Nominal flow rate: max. 380 l/min / 100 US GPM
- Materials: Filter head: Aluminium, Filter bowl: PA or Steel
- Connection: BSP or NPT, others on request



Type RTF-N

- Return-Line insert filter
- Custom reservoir design with an in-tank filtering system
- Magnetic pre-filtration
- Operating pressure: max. 10 bar / 145 PSI
- Nominal flow rate: max. 500 l/min / 132 US GPM
- Materials: Flange plate: Aluminium, Magnet rod / Bypass / Diffuser: Steel

Return-Line Filters ■ Type RF



RF-014/030 and RF-045/070



RF-090/130

Product Description

STAUFF RF Return-Line Filters are designed as tank top filters. They are mounted directly on the tank top and when 100% of the system's oil is filtered they provide the optimum removal of contaminant from the system. This provides the pump with clean oil thus reducing contaminant generated wear. The filter bowl is designed to return the oil beneath the surface thus preventing the entrainment of air by the returning oil. A high efficiency of contaminant removal is assured by using STAUFF RE Replacement Filter Elements. The high dirt-hold capacity of STAUFF Elements ensures a long service life and as a result reduced maintenance costs.

Technical Data
Construction

- Tank Top mounting

Materials

- Cover: RF-014/030 and RF-045/070: Glass Fibre reinforced Polyamide
RF-090/130: Aluminium
- Filter head: Aluminium
- Filter bowl: Glass Fibre reinforced Polyamide
- Sealings: NBR (Buna-N®)
FKM (Viton®)
EPDM (Ethylene-Propylene-Diene-Monomer-Rubber)
Other sealing materials on request

Port Connections

- BSP
- NPT
- SAE O-ring thread
- SAE flange 3000 PSI

Operating Pressure

- Max. 16 bar / 232 PSI

Temperature Range

- -20 °C ... +100 °C / -44 °F ... +212 °F
(Short term up to +110 °C / +230 °F)

Filter Elements

- Specifications see page 6

Media Compatibility

- Mineral oils, other fluids on request

Options and Accessories
Valve

- Bypass valve (integrated in the filter element):
Opening pressure 3 bar ± 0,3 bar / 43.5 PSI ± 4.35 PSI
Other settings available on request

Clogging Indicators

- For clogging indicator types please see page 7+8

Return-Line Filters ■ Type RF

D

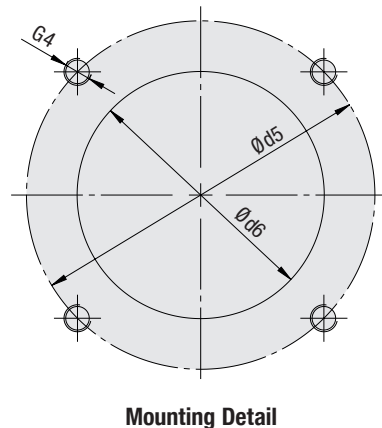
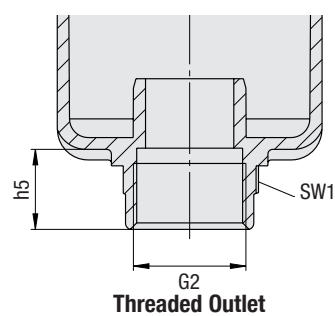
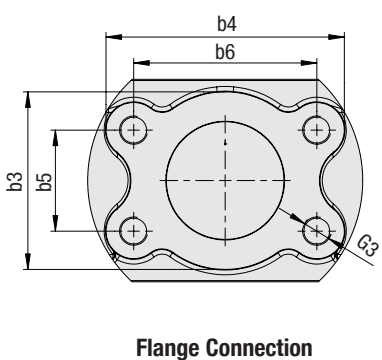
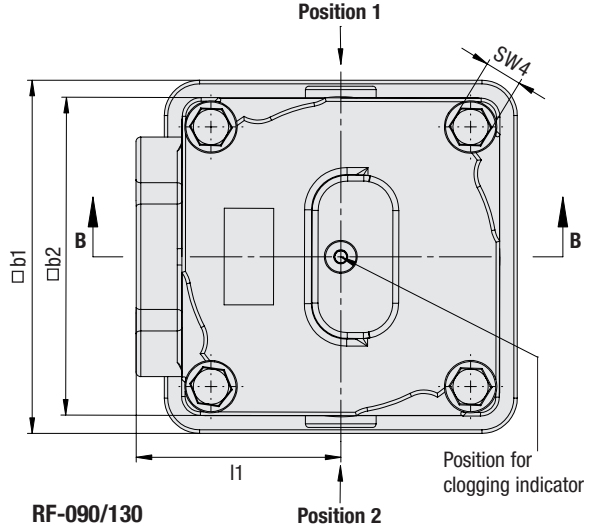
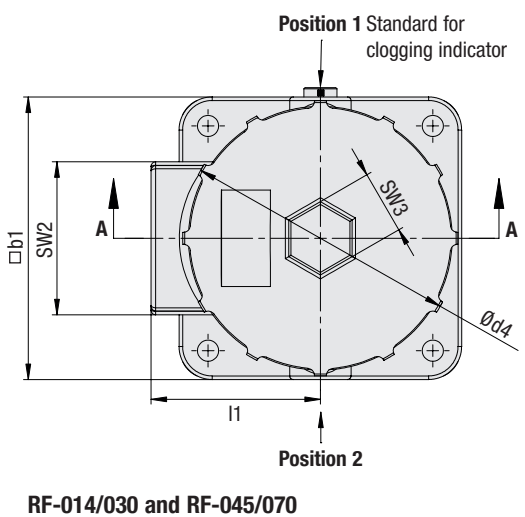
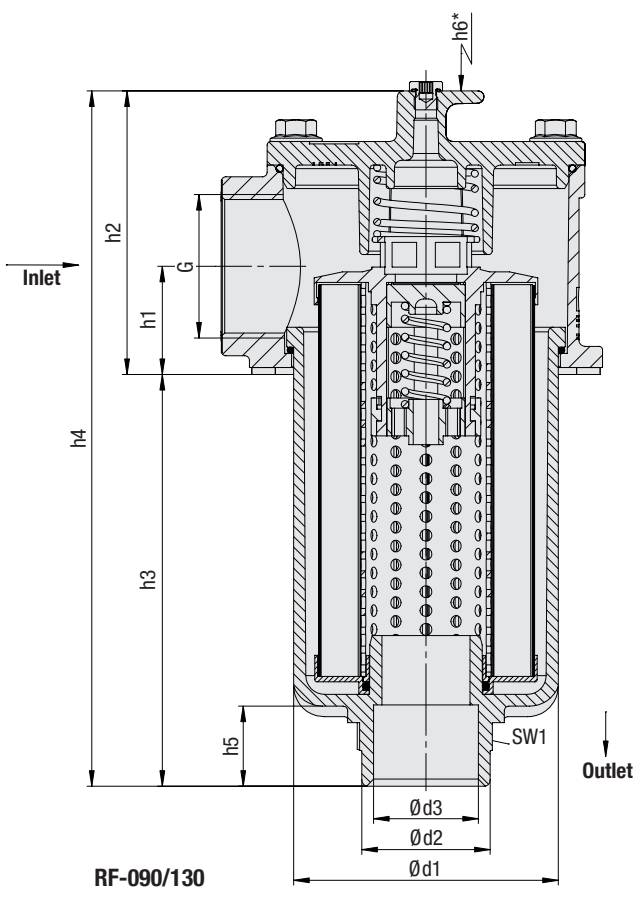
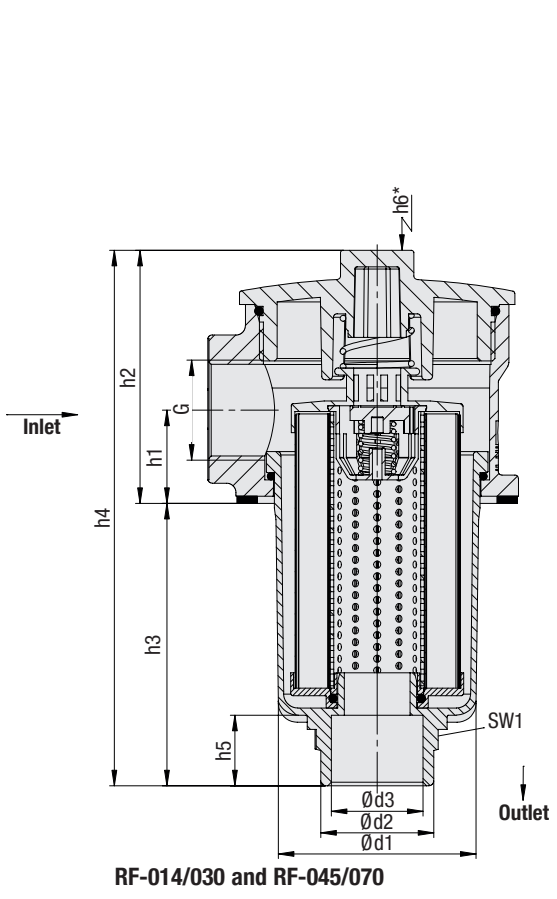

Return-Line Filters ■ Type RF

Connection Style G	Filter Size RF											
	014		030		045		070		090		130	
BSP	3/4	1	3/4	1	1-1/4	1-1/2	1-1/4	1-1/2	1-1/2	2	1-1/2	2
NPT	1		1		1-1/2		1-1/2		2		2	
SAE O-ring Thread	1-5/16-12		1-5/16-12		1-5/8-12 / 1-7/8-12		1-5/8-12 / 1-7/8-12		1-7/8-12		1-7/8-12	
SAE Flange 3000 PSI	-		-		-		-		2		2	

Dimensions (mm/in)	Filter Size RF											
	014		030		045		070		090		130	
b1	89		89		120		120		150		150	
	3.50		3.50		4.72		4.72		5.91		5.91	
b2	-		-		-		-		75,5		75,5	
	-		-		-		-		2.97		2.97	
b3	-		-		-		-		101		101	
	-		-		-		-		3.98		3.98	
b4	-		-		-		-		42,9		42,9	
	-		-		-		-		1.69		1.69	
b5	-		-		-		-		77,8		77,8	
	-		-		-		-		3.06		3.06	
d1	57,5		57,5		84		84		112,5		112,5	
	2.26		2.26		3.31		3.31		4.43		4.43	
d2	36		36		48		48		54,5		54,5	
	1.42		1.42		1.89		1.89		2.15		2.15	
d3	17		17		28		28		37,5		37,5	
	.67		.67		1.10		1.10		1.48		1.48	
d4	89		89		117		117		-		-	
	3.50		3.50		4.60		4.60		-		-	
d5	100		100		135		135		170		170	
	3.94		3.94		5.31		5.31		6.69		6.69	
d6	65		65		92		92		118		118	
	2.56		2.56		3.62		3.62		4.65		4.65	
h1	33		33		41		41		47		47	
	1.30		1.30		1.61		1.61		1.85		1.85	
h2	89,5		89,5		107,5		107,5		120,5		120,5	
	3.52		3.52		4.23		4.23		4.74		4.74	
h3	91,5		159,5		119		180		172,5		252,5	
	3.60		6.28		4.69		7.09		6.79		9.94	
h4	181,5		249,5		227,5		288,5		295,4		375,4	
	7.15		9.82		8.96		11.36		11.63		14.78	
h5	23,5		23,5		24		24		27		27	
	.93		.93		.95		.95		1.06		1.06	
h6	140		210		180		240		235		315	
	5.51		8.27		7.09		9.45		9.25		12.4	
l1	54		54		72		72		86		86	
	2.13		2.13		2.83		2.83		3.39		3.39	
G2	G1 or 1 NPT		G1 or 1 NPT		G1-1/4 or 1-1/4 NPT		G1-1/4 or 1-1/4 NPT		G1-1/2 or 1-1/2 NPT		G1-1/2 or 1-1/2 NPT	
G3	-		-		-		-		M12x20 or 1/2-13 UNC x 20		M12x20 or 1/2-13 UNC x 20	
G4	M6 or 1/4-20 UNC		M6 or 1/4-20 UNC		M8 or 5/16-18 UNC		M8 or 5/16-18 UNC		M10 or 3/8-16 UNC		M10 or 3/8-16 UNC	
SW1	36		36		50		50		55		55	
	1.42		1.42		1.97		1.97		2.16		2.16	
SW2	50		50		65		65		-		-	
	1.97		1.97		2.56		2.56		-		-	
SW3	22		27		27		27		-		-	
	0.87		.87		1.06		1.06		-		-	
SW4	-		-		-		-		15		15	
	-		-		-		-		.59		.59	

D

Return-Line Filter Housings / Complete Filters ■ Type RF

RF - **070** - **G** - **10** - **B** - **G24** - **G42NO** - **D** - **O** / **2**

① ② ③ ④ ⑤ ⑥ ⑦ ⑧ ⑨ ⑩

① Type

Return-Line Filter **RF**

② Group

Flow	Size
60 l/min / 14 US GPM	014
110 l/min / 30 US GPM	030
160 l/min / 45 US GPM	045
240 l/min / 70 US GPM	070
330 l/min / 90 US GPM	090
500 l/min / 130 US GPM	130

Note: Exact flow will depend on the selected filter element.
For technical data please see pages 9+10.

③ Filter Material

Material	max. Δp*collapse	Micron ratings available	Code
Without filter element	-	-	O
Inorg. glass fibre	25 bar / 363 PSI	3, 5, 10, 20	G
Stainless fibre	30 bar / 435 PSI		A
Filter paper	10 bar / 145 PSI	10, 20	N
Stainless mesh	30 bar / 435 PSI	25, 50, 100, 200	S

Note: *Collapse/burst resistance as per ISO 2941.
Other materials on request.

④ Micron Rating

3 µm	03
5 µm	05
10 µm	10
20 µm	20
25 µm	25
50 µm	50
100 µm	100
200 µm	200

Note: Other micron ratings on request.

⑤ Sealing Materials

NBR (Buna®)	B
FKM (Viton®)	V
EPDM	E

Note: Other sealing materials on request

⑥ Connection Style

Connection Style	Thread Style	Group 014/030	Code	Group 045/070	Code	Group 090/130	Code
BSP	-	3/4	G12	1-1/4	G20	1-1/2	G24
	-	1	G16	1-1/2	G24	2	G32
NPT	-	1	N16	1-1/2	N24	2	N32
SAE O-ring Thread	-	1-5/16	U16	1-5/8	U20	1-7/8	U24
	-	-	-	1-7/8-12	U24	-	-
SAE Flange 3000 PSI	metric	-	-	-	-	2	C332M
SAE Flange 3000 PSI	UNC	-	-	-	-	2	C332U

⑦ Clogging Indicator

Without Clogging Indicator	O
Visual Clogging Indicator	V
Electrical Clogging Switch 42 V, NO	G42NO
Electrical Clogging Switch 42 V, NC	G42NC
Electrical Clogging Switch 110 V ... 230 V, two-way contact (only for Code W)	G230

⑧ Option Clogging Indicator G42NO, G42NC and G230

Blanking Screw M10x1 (Delivery standard)	O
M12 x 1,5	M12
AMP plug	A
Deutsch plug	D
Rubber boot	S
90 degree Polyamide cap (only for Code G230)	W

⑨ Outlet Style

Size	Connection thread	Code
all	Without thread (Standard outlet)	O
014 / 030	1" BSP / 1" NPT	G16 / N16
045 / 070	1 1/4 BSP / 1 1/4 NPT	G20 / N20
090 / 130	1 1/2 BSP / 1 1/2 NPT	G24 / N24

⑩ Design Code

Only for information **2**

Note: Leakage Oil Connection on request.
Please see page 8.

Filter Elements ■ Type RE

RE - **014** - **G** - **10** - **B** / **X**

① ② ③ ④ ⑤ ⑥

① Type

Filter Element Series **RE**

② Group

According to filter housing

③ Filter Material

Material	Max. Δp*collapse	Micron ratings available	Code
Inorg. glass fibre	25 bar / 363 PSI	3, 5, 10, 20	G
Stainless fibre	30 bar / 435 PSI		A
Filter paper	10 bar / 145 PSI	10, 20	N
Stainless mesh	30 bar / 435 PSI	25, 50, 100, 200	S

Note: *Collapse/burst resistance as per ISO 2941. Other materials on request.

④ Micron Rating

3 µm	03
5 µm	05
10 µm	10
20 µm	20
25 µm	25
50 µm	50
100 µm	100
200 µm	200

Note: Other micron ratings on request.

⑤ Sealing Materials

NBR (Buna®)	B
FKM (Viton®)	V
EPDM	E

Note: Other sealing materials on request.

⑥ Design Code

Only for information **X**

Return-Line Filters ■ Type RF

Electrical Clogging Switch

The switch is used where an electrical signal is needed to indicate when the element needs to be changed. The switch can turn on a light, or shut the machine down, or any further function controlled by an electric signal. The switching pressure is 2,5 bar / 36.25 PSI and this allows the element to be changed before the bypass setting of 3 bar / 43.5 PSI is reached.

Standard type with plug connector and rubber cap. Available with DEUTSCH DT04-2P plug (industrial standard), AMP Junior Timer plug (industrial standard) and five-pin circular connector M12, A-coded, according to IEC 61076-2-101.

Technical Data

	Limit-Switch G42NO+NC	Limit-Switch G230
Switching Capacity	100 VA	1000 VA
Voltage	10...42 VAC/DC	10...250 VAC/DC
Current		10mA...4A
Switching Accuracy		± 0,5 bar at room temp. and new state
Switching Frequency		200/min
max. Pressure Ramp Rate		≤ 1 bar/ms
Degree of Protection	IP65 (plug type S and W), IP67 (plug type M12, A, D)	
Temperature Range	-30°C ... +100°C	-40°C ... +100°C

Order Code

Limit-Switch - **G42NO** - **S** - **M10** - **B2.5**

①

②

③

④

⑤

① Type

Limit-Switch

② Connector Type

Electrical Clogging Switch 10 V ... 42 V, NO	G42NO
Electrical Clogging Switch 10 V ... 42 V, NC	G42NC
Electrical Clogging Switch 10 V ... 250 V, two-way contact (only for Plug Type W)	G230

③ Plug Type

M12 Five-Pin Connector according to IEC 61076-2-101	M12
AMP-Junior-Timer Plug	A
DEUTSCH Plug DT04-2P	D
Rubber boot	S
90 degree Polyamide cap (only for Connector Type G230)	W

④ Thread Type

 M10 x 1 con. **M10**

⑤ Pressure Setting

 2,5 bar / 36.3 PSI **B2.5**

Dimensions Plug Type

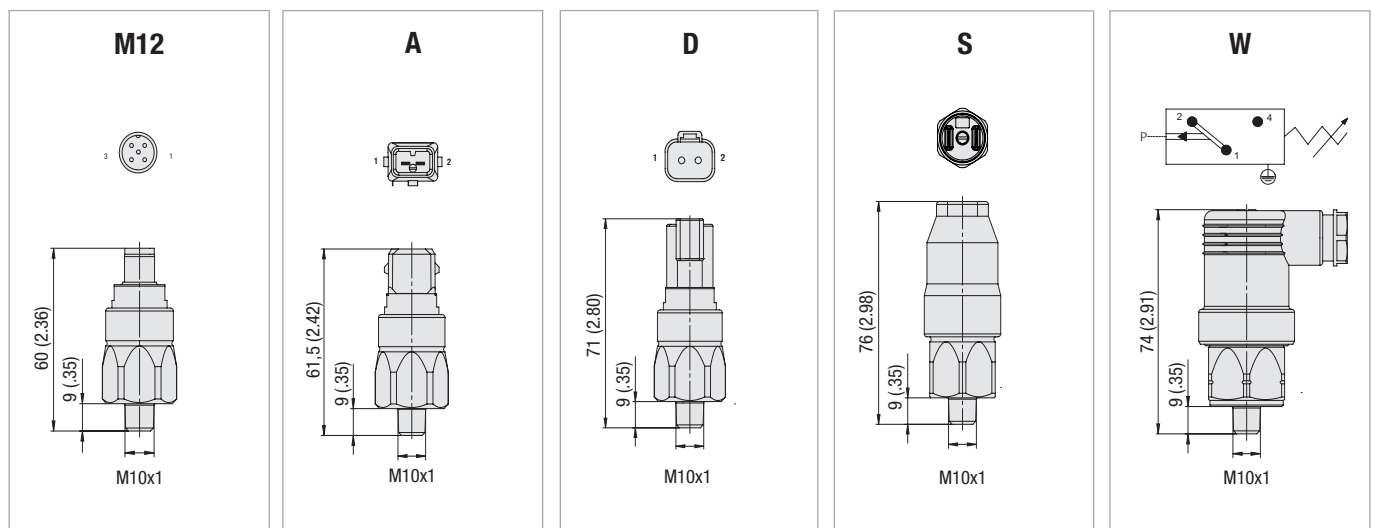

Note: The customer / user carries the responsibility for the electrical connection.

Return-Line Filters - Type RF

Visual Clogging Indicator

The gauge visually displays the degree of contamination of the element.
The colored segments allow quick visual checking.

green	0 ... 2,5 bar / 0 ... 36.25 PSI	Element has service life left
yellow	2,5 ... 3,0 bar / 36.25 ... 43.5 PSI	Element is contaminated and should be changed
red	>3,0 bar / >43.5 PSI	Bypass valve open, unfiltered oil passing to tank

Order Codes

SPG-C-040-00004-02-P-M10-402922



1 Type

Visual Clogging Indicator **SPG-C-040-00004-02-P-M10-402922**

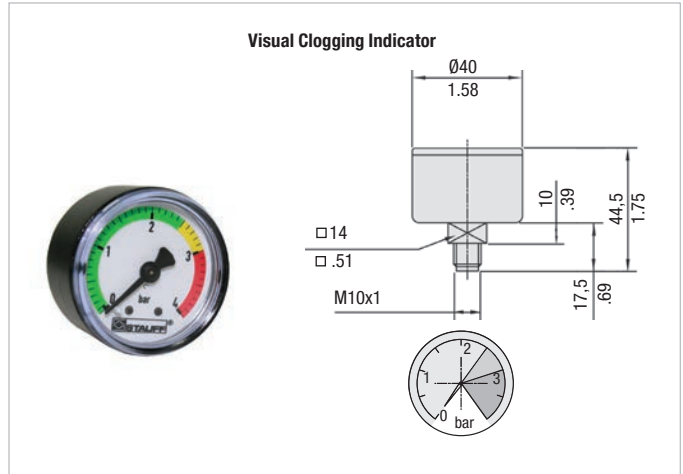

Filter Bowl with Threaded Connection

Under some circumstances such as a tall reservoir or one with oil levels which vary greatly during operation, it is necessary to extend the filter bowl so that the returning oil returns beneath the surface and does not entrain air in the process. The optional bowl with a female thread allows an extension to be fitted quite simply.

Leakage Oil Connection

Leakage oil connections can be provided at positions 1 + 2 (see page 4). Time-consuming installation of the leakage oil lines through the reservoir lid is no longer necessary and it is ensured that no unfiltered liquid gets back into the reservoir.

RF-014 to 070:	G1/4 resp. 1/4 NPT
RF-090/130:	up to max. G1/2 resp. 1/2 NPT

Filter Bowl with Threaded Connection and Diffuser

Diffusers mounted to the filter bowl minimise foaming and reduce noise of high Return-Line flows. For further details on STAUFF Diffusers please refer to the Catalogue No. 10 - Hydraulic Accessories.
Attention: Connection pipe not included in scope of delivery!

Size SRV	for Return-Line Filter Size	Dimensions (mm/in)		Thread G	Hex
		øD	L		
SRV-114-G16	RF-014/030	60	139	G1	46
SRV-114-N16		2.36	5.47	1 NPT	1.81
SRV-200-G20	RF-045/070	82	139	G1-1/4	60
SRV-200-N20		3.23	5.47	1-1/4 NPT	2.36
SRV-227-G24	RF-090/130	82	200	G1-1/2	60
SRV-227-N24		3.23	7.87	1-1/2 NPT	2.36

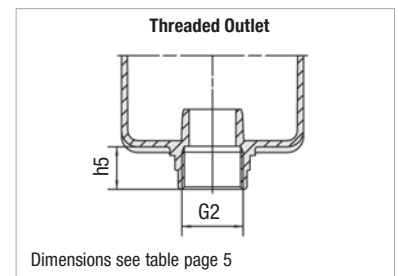

Dimensions see table page 5

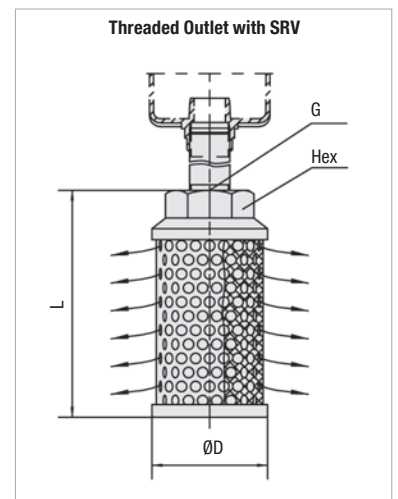
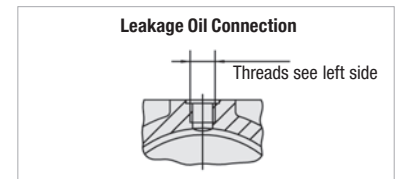

Return-Line Filters ▪ Type RF Flow Characteristics

The following characteristics are valid for mineral oils with a density of 0,85 kg/dm³ and the kinematic viscosity of 30 mm²/s (30cSt). The characteristics have been determined in accordance to ISO 3968. Multipass filter ratings have been obtained in accordance to ISO 16889. The housing pressure drop is directly proportional to the oil density. Contact STAUFF for details.

Housings RF-014/030

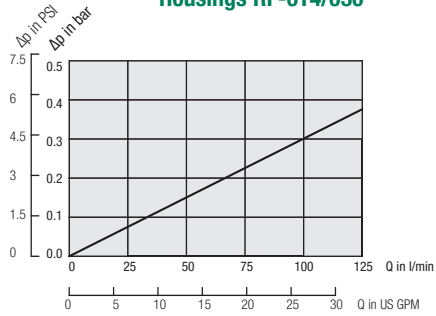

Housings RF-045/070

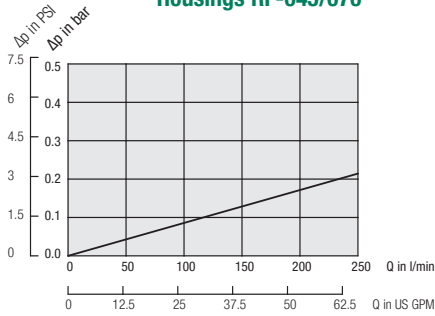

Housings RF-090/130

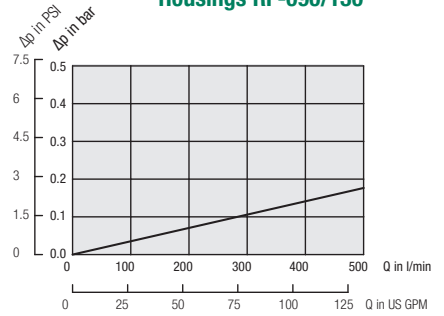

Filter Elements RE-014-G

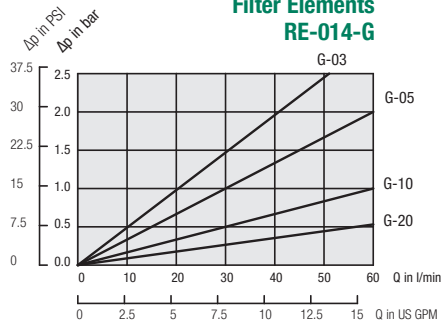

Filter Elements RE-030-G

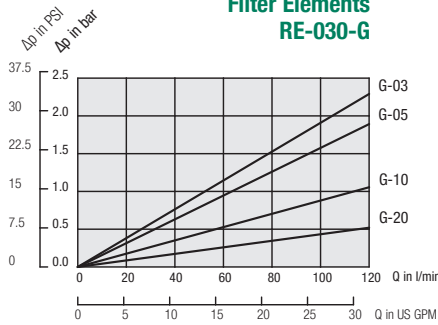

Filter Elements RE-045-G

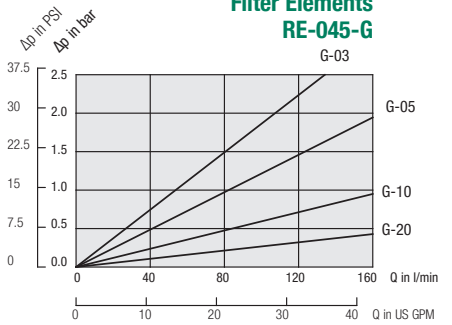

Filter Elements RE-070-G

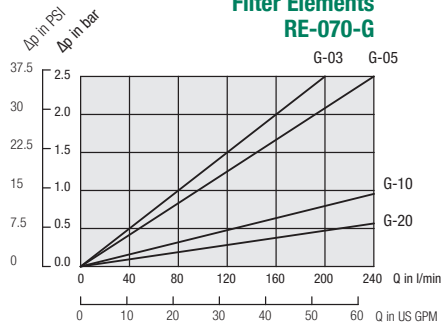

Filter Elements RE-090-G

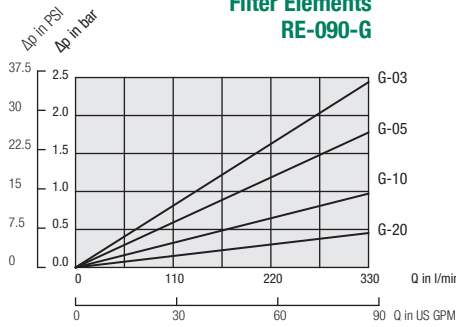

Filter Elements RE-130-G

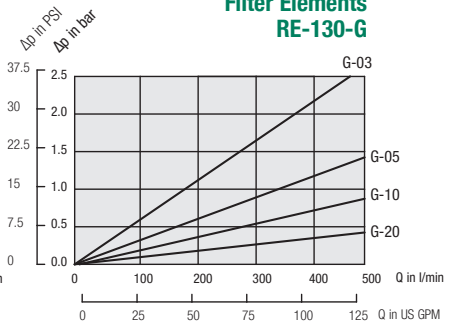

D

Return-Line Filters - Type RF Flow Characteristics

The following characteristics are valid for mineral oils with a density of 0,85 kg/dm³ and the kinematic viscosity of 30 mm²/s (30cSt). The characteristics have been determined in accordance to ISO 3968. Multipass filter ratings have been obtained in accordance to ISO 16889. The housing pressure drop is directly proportional to the oil density. Contact STAUFF for details.

D

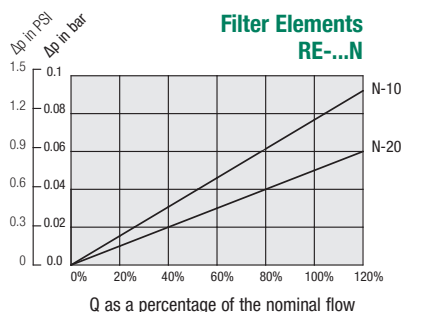
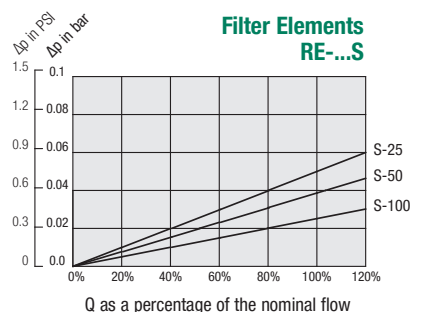
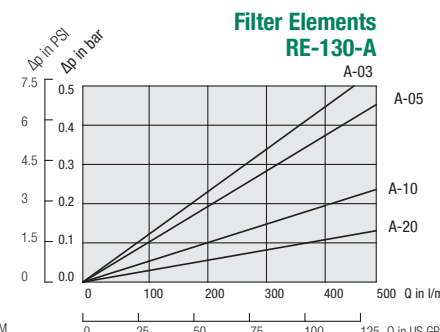
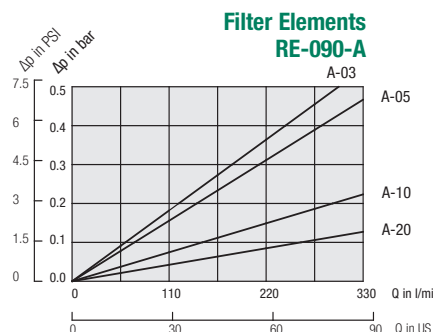
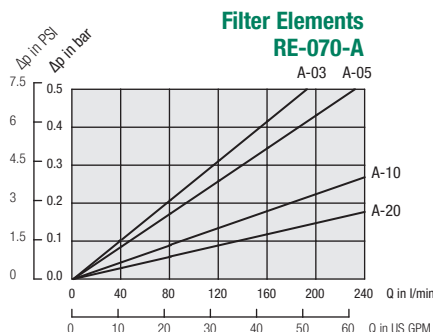
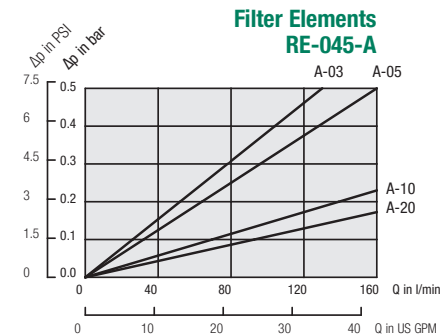
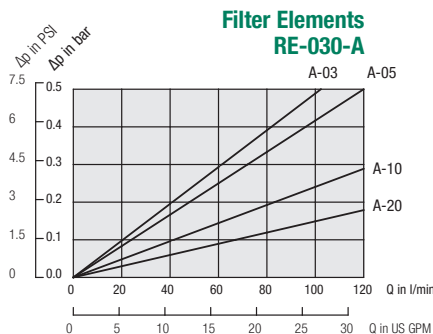
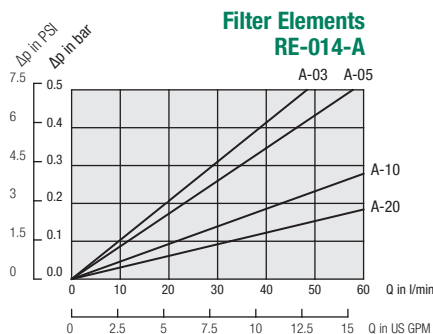

Return-Line Filters ▪ Type RFA



D

Product Description

STAUFF RFA Return-Line Filters are a one piece design and can be used as a tank top or an in-line filter. They are mounted in the Return-Line and if 100% of the system oil is filtered, provide the optimum removal of contaminant for the systems. This provides the pump with clean oil, thus reducing contaminant generated wear. A high efficiency of contaminant removal is assured by using STAUFF RE Replacement Filter Elements. The high dirt-hold capacity of STAUFF Elements ensures a long service life and as a result reduced maintenance costs. Furthermore, this housing also offers the possibility of pipeline mounting.

Technical Data
Construction

- Tank Top or in-line mounting

Materials

- Filter housing: Aluminium
- Sealings: NBR (Buna-N®)
FKM (Viton®)
EPDM (Ethylene Propylene Diene Monomer Rubber)
Other sealing materials on request

Port Connections

- SAE O-ring thread
- BSP

Operating Pressure

- Max. 25 bar / 365 PSI

Temperature Range

- -20 °C ... +100 °C / -44 °F ... +212 °F
(Short term up to +110 °C / +230 °F)

Filter Elements

- Specifications see page 80

Media Compatibility

- Mineral oils, other fluids on request

Options and Accessories
Valve

- Bypass valve (integrated in the filter element) Opening pressure 3 bar \pm 0,3 bar / 43.5 PSI \pm 4.35 PSI
Other settings available on request

Clogging Indicators

- For clogging indicator types please see page 81

Return-Line Filters ▪ Type RFA

D

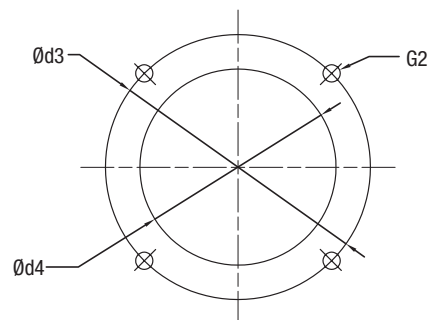
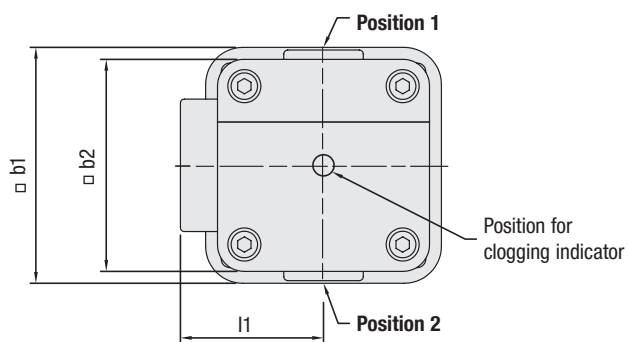
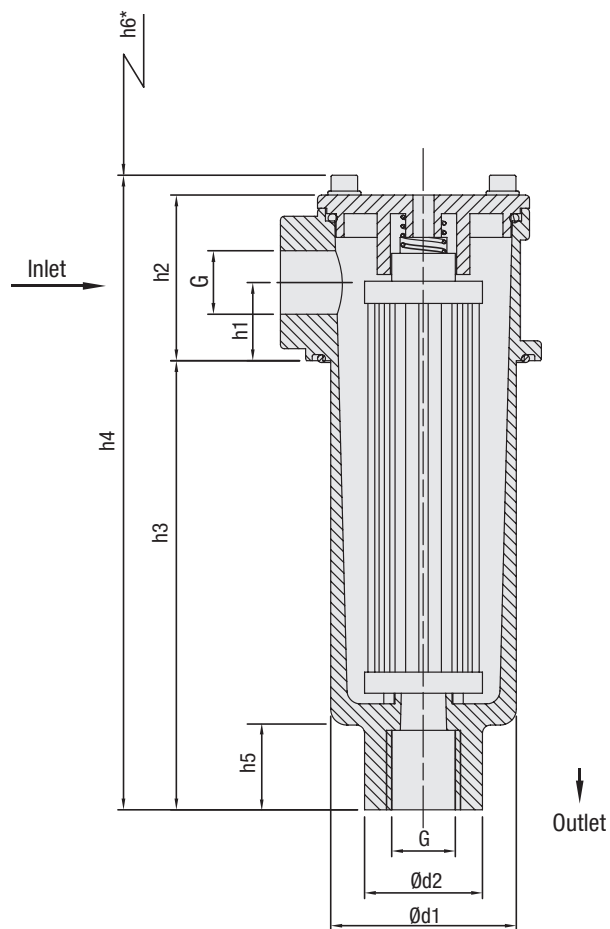

Mounting Detail

* recommended space for element change

Return-Line Filters ▪ Type RFA

Thread Connection G	Filter Size RFA-030
SAE O-ring Thread U12	1-1/16-12
SAE O-ring Thread U08	3/4-16
BSP G08	1/2
BSP G12	3/4

Dimensions (mm/in)	Filter Size RFA-030
h1	29,5
	1.16
h2	62,5
	2.46
h3	163,5
	6.44
h4	233,5
	9.19
h5	28
	1.10
h6	210
	8.27
b1	89
	3.50
b2	80
	3.15
d1	70
	2.76
d2	44,5
	1.75
d3	100
	3.94
d4	74
	2.91
l1	54
	2.16
G2	M6 or 1/4 UNC

D

Return-Line Filter Housings / Complete Filters ▪ Type RFA



① Type

Return-Line Filter **RFA**

② Group

Flow **Size**
 110 l/min / 30 US GPM **030**
 Note: Exact flow will depend on the selected filter element.
 For technical data please see page 83.

③ Filter Material

Material	Max. Δp*collapse	Micron ratings available	Code
Without filter element	-	-	0
Inorg. glass fibre	25 bar / 363 PSI	3, 5, 10, 20	G
Stainless fibre	30 bar / 435 PSI		A
Filter paper	10 bar / 145 PSI	10, 20	N
Stainless mesh	30 bar / 435 PSI	25, 50, 100, 200	B, S

Note: *Collapse/burst resistance as per ISO 2941. Other materials on request.

④ Micron Rating

3 µm	03
5 µm	05
10 µm	10
20 µm	20
25 µm	25
50 µm	50
100 µm	100
200 µm	200

Note: Other micron ratings on request.

⑤ Sealing Material

NBR (Buna®) **B**
 FKM (Viton®) **V**
 EPDM **E**
 Note: Other sealing materials on request

⑥ Connection Style

Connection Style	Thread	Code
SAE-O-ring Thread	1-1/16-12	U12
SAE-O-ring Thread	3/4-16	U08
BSP	1/2	G08
BSP	3/4	G12

⑦ Clogging Indicator

Without Clogging Indicator **0**
 Visual Clogging Indicator **V**
 Electrical Clogging Switch 42 V, NO **G42NO**
 Electrical Clogging Switch 42 V, NC **G42NC**
 Electrical Clogging Switch 230 V, two-way contact (only for Code W) **G230**

⑧ Option Clogging Indicator G42NO, G42NC and G230

Plug connector **0**
 M12 x 1,5 **M12**
 AMP plug **A**
 Deutsch plug **D**
 Rubber boot **S**
 90 degree Polyamide cap (only for Code G230) **W**

⑨ Outlet Style

Connection Style	Thread	Code
	Without thread (Standard outlet)	0
SAE-O-Ring Thread	1-1/16-12	U12
SAE-O-Ring Thread	3/4-16	U08
BSP	1/2	G08
BSP	3/4	G12

⑩ Additional Features

	Position*		
Without leakage oil connection	-		none
Leakage oil connection	1	2	L1

Note: *Position of the leakage oil connection see page 78.
 Without any code: assembly in the middle of the filter cover.

⑪ Design Code

Only for information **X**

Filter Elements ▪ Type RE

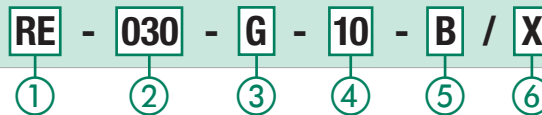

① Type

Filter Element Series **RE**

② Group

According to filter housing

③ Filter Material

Material	Max. Δp*collapse	Micron ratings available	Code
Inorg. glass fibre	25 bar / 363 PSI	3, 5, 10, 20	G
Stainless fibre	30 bar / 435 PSI		A
Filter paper	10 bar / 145 PSI	10, 20	N
Stainless mesh	30 bar / 435 PSI	25, 50, 100, 200	B, S

Note: *Collapse/burst resistance as per ISO 2941. Other materials on request.

④ Micron Rating

3 µm	03
5 µm	05
10 µm	10
20 µm	20
25 µm	25
50 µm	50
100 µm	100
200 µm	200

Note: Other micron ratings on request.

⑤ Sealing Materials

NBR (Buna®) **B**
 FKM (Viton®) **V**
 EPDM **E**
 Note: Other sealing materials on request.

⑥ Design Code

Only for information **X**

Return-Line Filters ■ Type RFA

Electrical Clogging Switch

The switch is used where an electrical signal is needed to indicate when the element needs to be changed. The switch can turn on a light, or shut the machine down, or any further function controlled by an electric signal. The switching pressure is 2,5 bar / 36.25 PSI and this allows the element to be changed before the bypass setting of 3 bar / 43.5 PSI is reached.

Standard type with plug connector and rubber cap. Available with DEUTSCH DT04-2P plug (industrial standard), AMP Junior Timer plug (industrial standard) and five-pin circular connector M12, A-coded, according to IEC 61076-2-101.

Technical Data

	Limit-Switch G42NO+NC	Limit-Switch G230
Switching Capacity	100 VA	1000 VA
Voltage	10...42 VAC/DC	10...250 VAC/DC
Current		10mA...4A
Switching Accuracy		± 0,5 bar at room temp. and new state
Switching Frequency		200/min
max. Pressure Ramp Rate		≤ 1 bar/ms
Degree of Protection	IP65 (plug type S and W), IP67 (plug type M12, A, D)	
Temperature Range	-30°C ... +100°C	-40°C ... +100°C

Order Code

Limit-Switch - G42NO - S - M10 - B2.5

①

②

③

④

⑤

① Type

Limit-Switch

② Connector Type

Electrical Clogging Switch 10 V ... 42 V, NO	G42NO
Electrical Clogging Switch 10 V ... 42 V, NC	G42NC
Electrical Clogging Switch 10 V ... 250 V, two-way contact (only for Plug Type W)	G230

③ Plug Type

M12 Five-Pin Connector according to IEC 61076-2-101	M12
AMP-Junior-Timer Plug	A
DEUTSCH Plug DT04-2P	D
Rubber boot	S
90 degree Polyamide cap (only for Connector Type G230)	W

④ Thread Type

 M10 x 1 con. **M10**

⑤ Pressure Setting

 2,5 bar / 36.3 PSI **B2.5**

Dimensions Plug Type

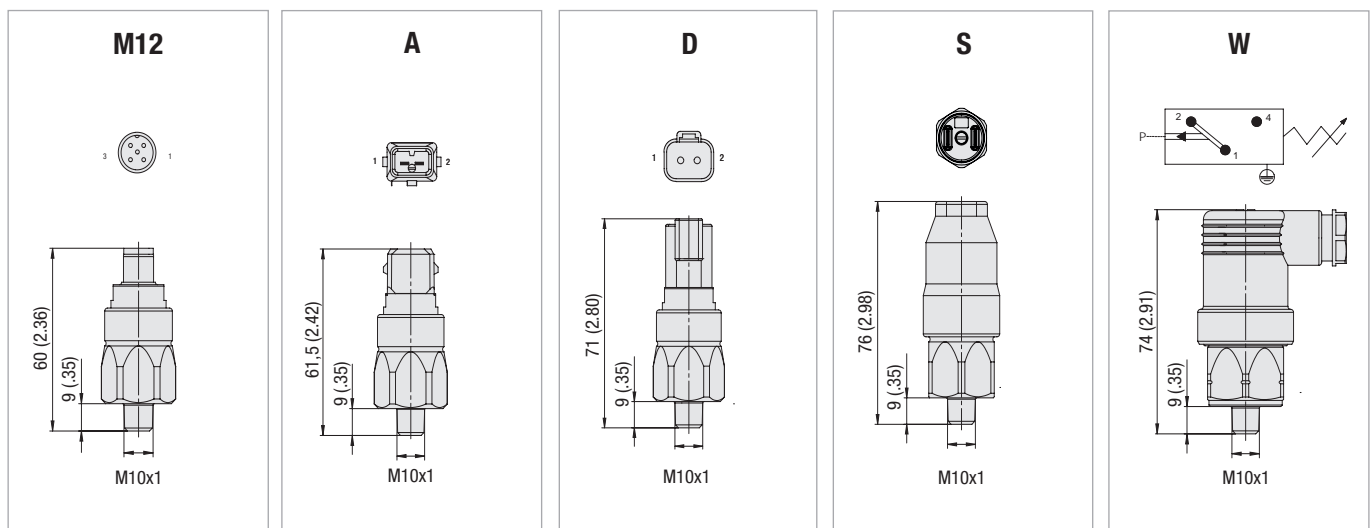

Note: The customer / user carries the responsibility for the electrical connection.

Return-Line Filters - Type RFA

Visual Clogging Indicator

The gauge visually displays the degree of contamination of the element. The colored segments allow quick visual checking.

green	0 ... 2,5 bar / 0 ... 36.25 PSI	Element has service life left
yellow	2,5 ... 3,0 bar / 36.25 ... 43.5 PSI	Element is contaminated and should be changed
red	>3,0 bar / >43.5 PSI	Bypass valve open, unfiltered oil passing to tank

Order Codes

SPG-C-040-00004-02-P-M10-402922

①

① Type

Visual Clogging Indicator **SPG-C-040-00004-02-P-M10-402922**

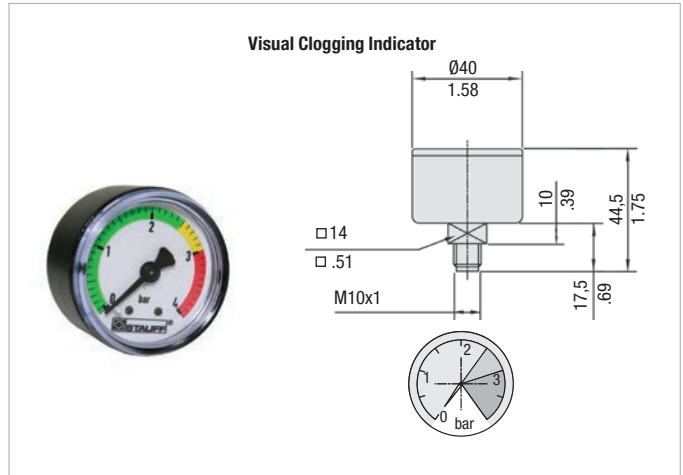

Filter Bowl with Threaded Connection

Under some circumstances such as a tall reservoir or one with oil levels which vary greatly during operation, it is necessary to extend the filter bowl so that the returning oil returns beneath the surface and does not entrain air in the process. The optional bowl with a female thread allows an extension to be fitted quite simply. The one piece design also allows for inline applications.

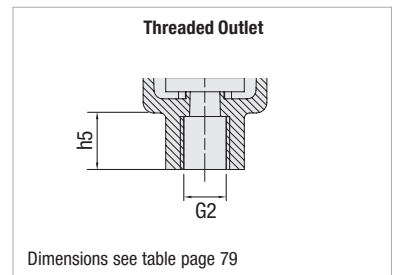

Leakage Oil Connection

Seal or case drain lines can be connected to the filter through either of the clogging indicator ports providing that the leakage oil can accept a pressure of 3 bar / 43.5 PSI. It ensures that no unfiltered oil can return to the reservoir.

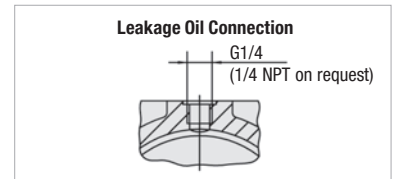

Filter Bowl with Threaded Connection and Diffuser

Diffusers mounted to the filter bowl minimise foaming and reduce noise of high Return-Line flows. For further details on STAUFF Diffusers please refer to the Catalogue No. 10 - Hydraulic Accessories. Attention: Connection pipe not included in scope of delivery!

Size SRV	for Return-Line Filter Size	Dimensions (mm/in)		Thread G	Hex
		øD	L		
SRV-050-G12	RFA-030	62	109	G3/4	36
SRV-050-N12		2.44	4.29	3/4 NPT	1.42

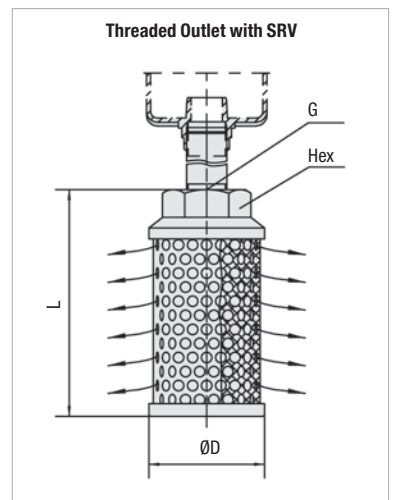

Return-Line Filters ■ Type RFA Flow Characteristics

The following characteristics are valid for mineral oils with a density of 0,85 kg/dm³ and the kinematic viscosity of 30 mm²/s (30cSt). The characteristics have been determined in accordance to ISO 3968. Multipass filter ratings have been obtained in accordance to ISO 16889. The housing pressure drop is directly proportional to the oil density. Contact STAUFF for details.

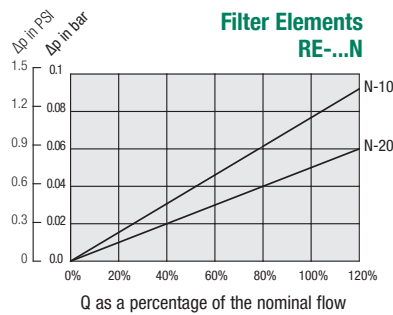
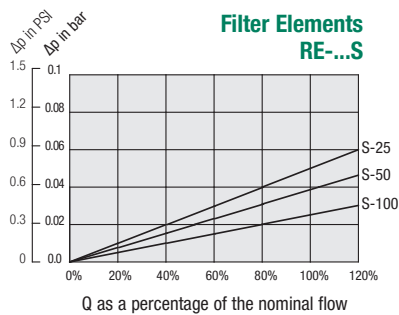
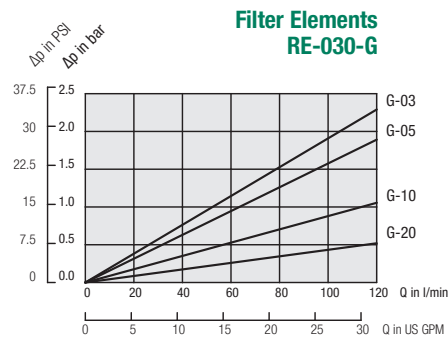
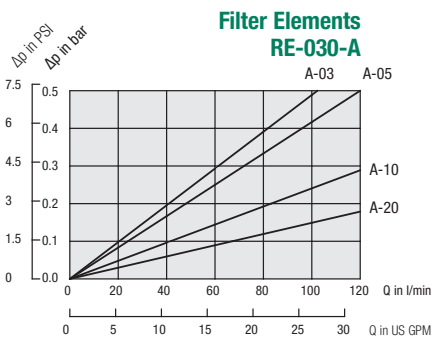
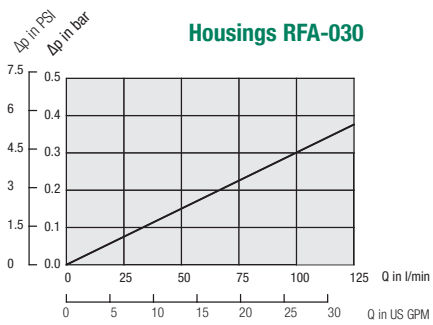

D

Checklist for the selection of filter housings

Please use the following Checklist as a guideline when preparing an enquiry for the selection of filter housings. Scan or copy the page from the catalogue, print and com-

plete it with as much information as possible, before sending it by email or fax to the closest STAUFF branch office. If possible, please also let us know the quantities required,

and if the enquiry is for a one-time or recurring demand. We look forward to hearing from you, and are always available for consultation, when required.

D

Information on the fluid in use					
Type of fluid	<input type="text"/>	Brand	<input type="text"/>	ISO designation	
Fluid viscosity	<input type="text"/>	<input type="checkbox"/>	mm ² /sec	<input type="checkbox"/>	cSt
Fluid temperature	<input type="text"/>	°C	<input type="checkbox"/>	°F	<input type="checkbox"/>
	<input type="text"/>		In cold condition	<input type="checkbox"/>	In warm condition
Information on the filter housing					
Position in the hydraulic system	<input type="checkbox"/>	Suction line	<input type="checkbox"/>	Pressure line	<input type="checkbox"/>
					Return line
Operating pressure	<input type="text"/>	<input type="checkbox"/>	bar	<input type="checkbox"/>	PSI
Nominal flow	<input type="text"/>	<input type="checkbox"/>	l/min	<input type="checkbox"/>	US GPM
Valve	<input type="checkbox"/>	No, not required			
	<input type="checkbox"/>	Yes, the following type:			
		<input type="checkbox"/>	Bypass valve	<input type="checkbox"/>	Non-return valve
				<input type="checkbox"/>	Reverse flow valve
				<input type="checkbox"/>	Multi-function valve
Clogging indicator	<input type="checkbox"/>	No, not required			
	<input type="checkbox"/>	Yes, the following type:			
		<input type="checkbox"/>	Visual	<input type="checkbox"/>	Electrical
				<input type="checkbox"/>	Visual-electrical
Connection type and size	<input type="text"/>				
Sealing material	<input type="checkbox"/>	NBR (Buna®)	<input type="checkbox"/>	FKM (Viton®)	<input type="text"/>
					Other
Information on the filter element					
Filter media	<input type="checkbox"/>	Inorganic Glass Fibre	<input type="checkbox"/>	Polyester Fibre	<input type="checkbox"/>
					Cellulose Fibre
				<input type="checkbox"/>	Stainless Fibre
				<input type="checkbox"/>	Stainless Mesh
Micron rating	<input type="text"/>	µm			
Cleanliness level	<input type="text"/>	(to ISO 4406)			
Information on the application	<input type="text"/>				
Information on the ambient conditions	<input type="text"/>				
Additional information and requirements	<input type="text"/>				

Return-Line Filters ▪ Type RFB

Product Description

STAUFF RFB Return-Line Filters are designed as tank top filters. They are mounted directly on the tank top and if 100% of the system oil is filtered they provide the optimum removal of contaminant from the system. This provides the pump with clean oil thus reducing contaminant generated wear. Because of its low weight and compact design, the STAUFF RFB Filters are ideally suited for mobile hydraulic applications. A high efficiency of contaminant removal is assured by using STAUFF RE Replacement Filter Elements. The high dirt-hold capacity of STAUFF Elements ensures a long service life and as a result reduced maintenance costs.

Technical Data
Construction

- Tank Top flange mounting

Materials

- Filter head: Aluminium
- Filter bowl & cap: Glass Fibre Reinforced Polyamide
- Sealings: NBR (Buna-N®)
FKM (Viton®)
EPDM (Ethylene Propylene Diene Monomer Rubber)
Other sealing materials on request

Port Connections

- BSP
- NPT
- SAE O-ring thread

Operating Pressure

- Max. 10 bar / 145 PSI

Temperature Range

- -20 °C ... +100 °C / -44 °F ... +212 °F
(Short term up to +110 °C / +230 °F)

Filter Elements

- Specifications see page 88

Media Compatibility

- Mineral oils, other fluids on request

Options and Accessories
Valve

- Bypass valve (integrated in the filter element) Opening pressure 3 bar ± 0,3 bar / 43.5 PSI ± 4.35 PSI
Other settings available on request

Clogging Indicators

- For clogging indicator types please see page 89

Return-Line Filters ■ Type RFB

D

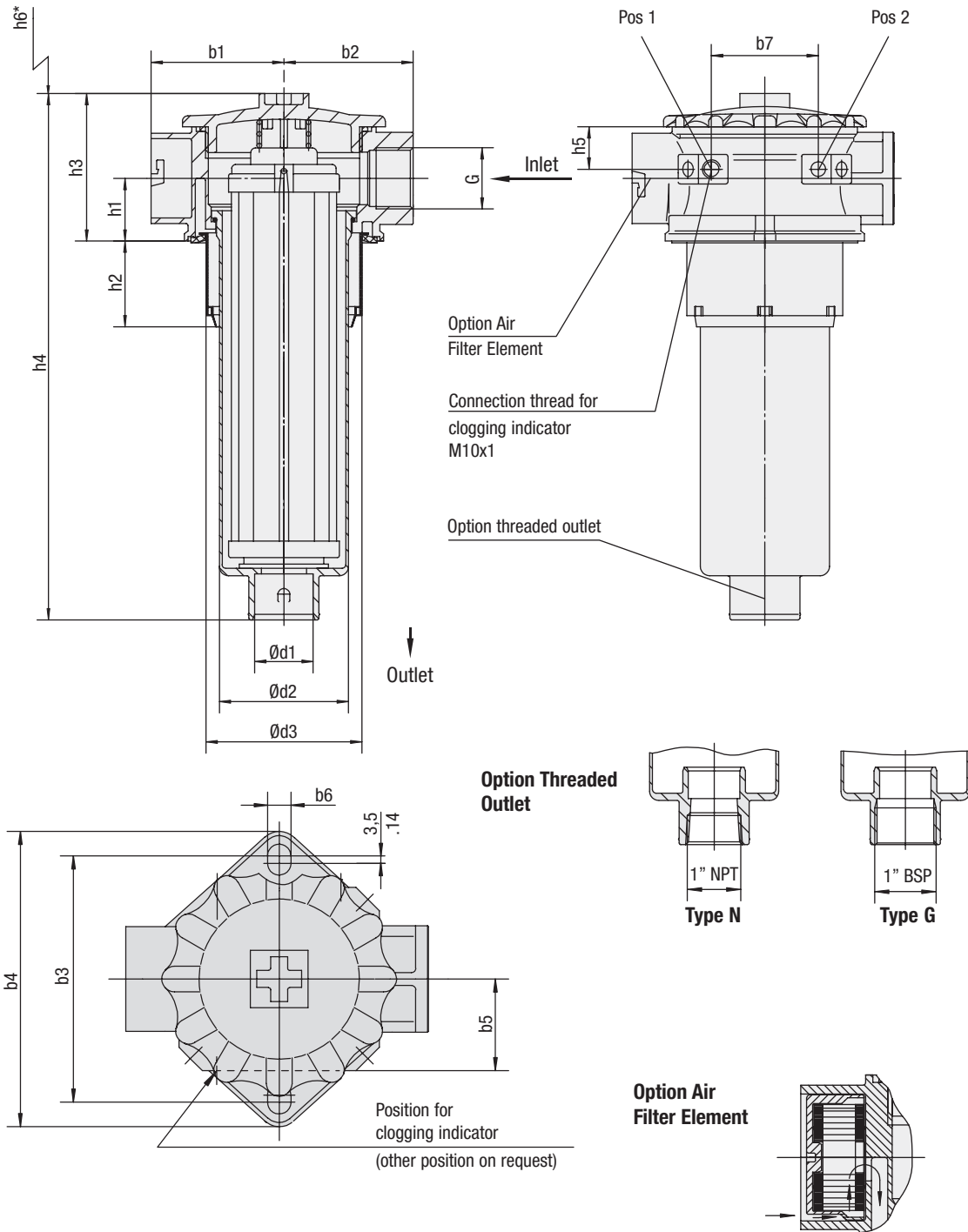

* recommended space for element change

Return-Line Filters ▪ Type RFB

Thread Connection G	Filter Size RFB					
	022		046		052	
BSP	3/4	1	3/4	1	3/4	1
NPT	3/4	1	3/4	1	3/4	1
SAE O-ring Thread	1-5/16-12					

Dimensions (mm/in)	Filter Size RFB		
	022	046	052
h1	34	34	34
	1.34	1.34	1.34
h2	46,5	46,5	46,5
	1.83	1.83	1.83
h3	80	80	80
	3.15	3.15	3.15
h4	205,5	285,5	351,5
	8.09	11.24	13.84
h5	23	23	23
	.91	.91	.91
h6	154	239	305
	6.26	9.41	12.01
d1	32	32	32
	1.26	1.26	1.26
d2	70	70	70
	2.76	2.76	2.76
d3	84,5	84,5	84,5
	3.33	3.33	3.33
b1	72	72	72
	2.84	2.84	2.84
b2	70	70	70
	2.76	2.76	2.76
b3	115,5	115,5	115,5
	4.55	4.55	4.55
b4	138,5	138,5	138,5
	5.45	5.45	5.45
b5	43	43	43
	1.69	1.69	1.69
b6	11	11	11
	.43	.43	.43
b7	58	58	58
	2.28	2.28	2.28

Return-Line Filter Housings / Complete Filters ■ Type RFB

RFB - **022** - **G** - **10** - **B** - **G16** - **G42NO** - **D** - **G** - **L10** / **X**

① ② ③ ④ ⑤ ⑥ ⑦ ⑧ ⑨ ⑩ ⑪

① Type

Return-Line Filter **RFB**

② Group

Flow	Size
75 l/min / 22 US GPM	022
165 l/min / 46 US GPM	046
185 l/min / 52 US GPM	052

Note: Exact flow will depend on the selected filter element.
For technical data please see page 91.

③ Filter Material

Material	Max. Δp*collapse	Micron ratings available	Code
Without filter element	-	-	0
Inorg. glass fibre	25 bar / 363 PSI	3, 5, 10, 20	G
Stainless fibre	30 bar / 435 PSI		M
Filter paper	10 bar / 145 PSI	10, 20	N
Stainless mesh	30 bar / 435 PSI	10, 25, 50, 100, 200	S

Note: *Collapse/burst resistance as per ISO 2941.
Other materials on request.

④ Micron Rating

3 μm	03
5 μm	05
10 μm	10
20 μm	20
25 μm	25
50 μm	50
100 μm	100
200 μm	200

Note: Other micron ratings on request.

⑤ Sealing Material

NBR (Buna®)	B
FKM (Viton®)	V
EPDM	E

Note: Other sealing materials on request.

⑥ Connection Style

Connection Style		Code
BSP	1	G16
BSP	3/4	G12
NPT	1	N16
NPT	3/4	N12
SAE-O-ring Thread	1-5/16-12	U16

Note: Bold types identify preferred connection style.

⑦ Clogging Indicator

Without Clogging Indicator	0
Visual Clogging Indicator	V
Electrical Clogging Switch 42 V, NO	G42NO
Electrical Clogging Switch 42 V, NC	G42NC
Electrical Clogging Switch 110 V ... 230 V, two-way contact (only for Code W)	G230

⑧ Option Clogging Indicator G42NO, G42NC and G230

Plug connector	0
M12 x 1,5	M12
AMP plug	A
Deutsch plug	D
Rubber boot	S
90 degree Polyamide cap (only for Code G230)	W

⑨ Outlet Style

With 1" BSP thread	G16
With 1" NPT thread	N16

⑩ Air Filter Element

Without Air Filter Element	none
Filter paper 10 micron	L10

Note: Other materials and micron ratings on request.

⑪ Design Code

Only for information	X
----------------------	----------

Filter Elements ■ Type RE

RE - **022** - **G** - **10** - **B** / **X**

① ② ③ ④ ⑤ ⑥

① Type

Filter Element Series **RE**

② Group

According to filter housing

③ Filter Material

Material	Max. Δp*collapse	Micron ratings available	Code
Inorg. glass fibre	25 bar / 363 PSI	3, 5, 10, 20	G
Stainless fibre	30 bar / 435 PSI		M
Filter paper	10 bar / 145 PSI	10, 20	N
Stainless mesh	30 bar / 435 PSI	25, 50, 100, 200	S

Note: *Collapse/burst resistance as per ISO 2941.
Other materials on request.

④ Micron Rating

3 μm	03
5 μm	05
10 μm	10
20 μm	20
25 μm	25
50 μm	50
100 μm	100
200 μm	200

Note: Other micron ratings on request.

⑤ Sealing Material

NBR (Buna®)	B
FKM (Viton®)	V
EPDM	E

Note: Other sealing material on request.

⑥ Design Code

Only for information	X
----------------------	----------

Air Filter Element

KIT-RFB-AIR - **L** - **10** / **X**

① ② ③ ④

① Type

Air filter for RFB-022/046/052 **KIT-RFB-AIR**

② Filter Material

Filter Paper **L**
Note: Other materials on request.

③ Micron Rating

10 μm	10
-------	-----------

Note: Other micron ratings on request.

④ Design Code

Only for information	X
----------------------	----------

Return-Line Filters ■ Type RFB

Electrical Clogging Switch

The switch is used where an electrical signal is needed to indicate when the element needs to be changed. The switch can turn on a light, or shut the machine down, or any further function controlled by an electric signal. The switching pressure is 2,5 bar / 36.25 PSI and this allows the element to be changed before the bypass setting of 3 bar / 43.5 PSI is reached.

Standard type with plug connector and rubber cap. Available with DEUTSCH DT04-2P plug (industrial standard), AMP Junior Timer plug (industrial standard) and five-pin circular connector M12, A-coded, according to IEC 61076-2-101.

Technical Data

	Limit-Switch G42NO+NC	Limit-Switch G230
Switching Capacity	100 VA	1000 VA
Voltage	10...42 VAC/DC	10...250 VAC/DC
Current		10mA...4A
Switching Accuracy		± 0,5 bar at room temp. and new state
Switching Frequency		200/min
max. Pressure Ramp Rate		≤ 1 bar/ms
Degree of Protection	IP65 (plug type S and W), IP67 (plug type M12, A, D)	
Temperature Range	-30°C ... +100°C	-40°C ... +100°C

Order Code

Limit-Switch - G42NO - S - M10 - B2.5

①

②

③

④

⑤

① Type

Limit-Switch

② Connector Type

Electrical Clogging Switch 10 V ... 42 V, NO	G42NO
Electrical Clogging Switch 10 V ... 42 V, NC	G42NC
Electrical Clogging Switch 10 V ... 250 V, two-way contact (only for Plug Type W)	G230

③ Plug Type

M12 Five-Pin Connector according to IEC 61076-2-101	M12
AMP-Junior-Timer Plug	A
DEUTSCH Plug DT04-2P	D
Rubber boot	S
90 degree Polyamide cap (only for Connector Type G230)	W

④ Thread Type

 M10 x 1 con. **M10**

⑤ Pressure Setting

 2,5 bar / 36.3 PSI **B2.5**

Dimensions Plug Type

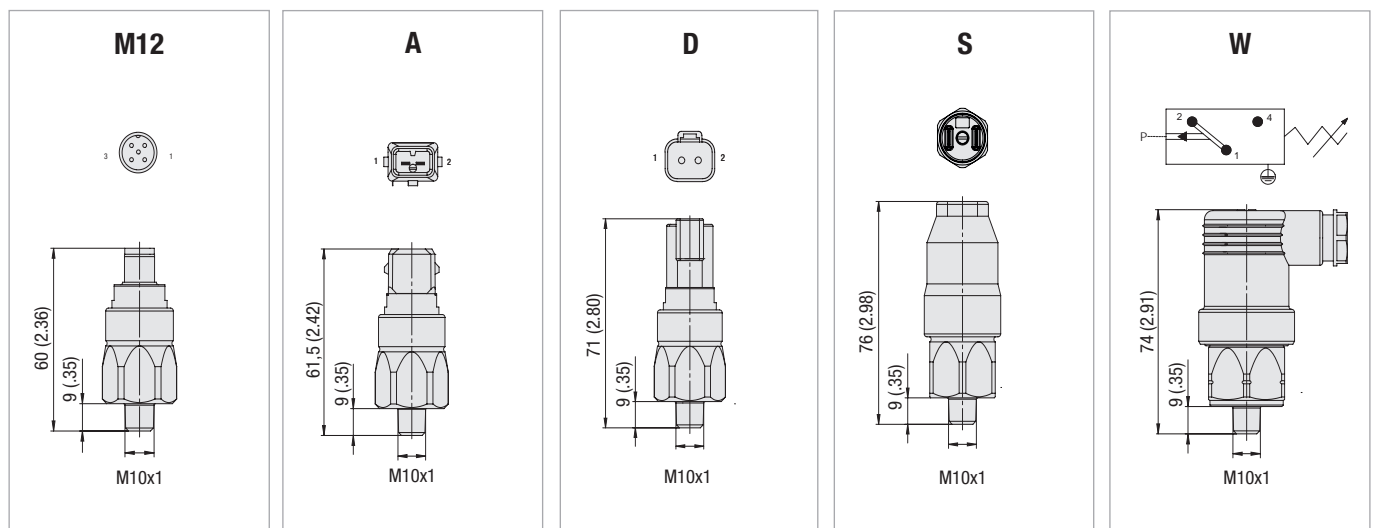

Note: The customer / user carries the responsibility for the electrical connection.

Return-Line Filters - Type RFB

Visual Clogging Indicator

The gauge visually displays the degree of contamination of the element.
The colored segments allow quick visual checking.

green	0 ... 2,5 bar / 0 ... 36.25 PSI	Element has service life left
yellow	2,5 ... 3,0 bar / 36.25 ... 43.5 PSI	Element is contaminated and should be changed
red	>3,0 bar / >43.5 PSI	Bypass valve open, unfiltered oil passing to tank

Order Codes

SPG-C-040-00004-02-P-M10-402922



① Type

Visual Clogging Indicator **SPG-C-040-00004-02-P-M10-402922**

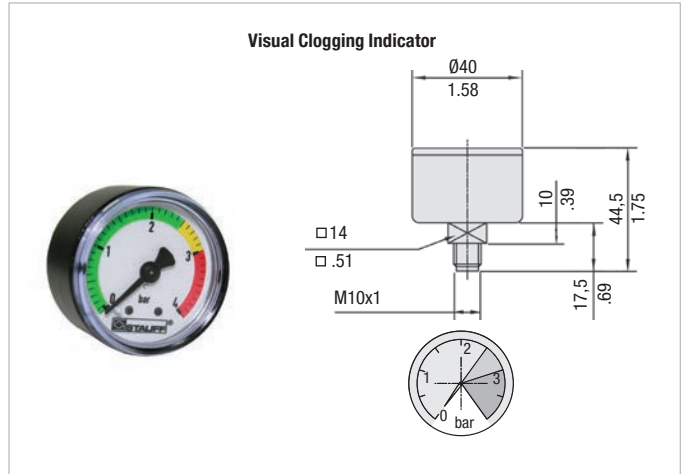

Filter Bowl with Threaded Connection

Under some circumstances such as a tall reservoir or one with oil levels which vary greatly during operation, it is necessary to extend the filter bowl so that the returning oil returns beneath the surface and does not entrain air in the process. The bowl with a female thread allows an extension to be fitted quite simply.

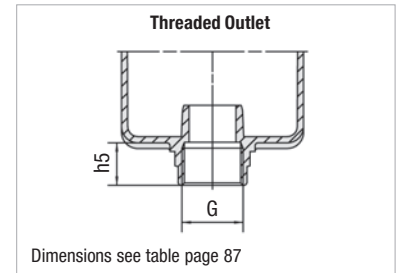

Air Filter Element

Allows an effective filtration of the incoming air which avoids the infiltration of dirt particles into the hydraulic system. The standard air filter element is a 10 micron cellulose; other materials and micron ratings on request.

Order Code

REA-046-L-10-B



① Type

Air Filter Element **REA-046-L-10-B**

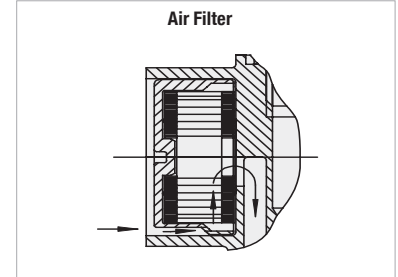

Filter Bowl with Threaded Connection and Diffuser

Diffusers mounted to the filter bowl minimise foaming and reduce noise of high Return-Line flows. For further details on STAUFF Diffusers please refer to the Catalogue No. 10 - Hydraulic Accessories. Attention: Connection pipe not included in scope of delivery!

Size SRV	for Return-Line Filter Size	Dimensions (mm/in)		Thread G	Hex
		øD	L		
SRV-114-G16	RFB-022/046/052	60	139	G1	46
SRV-114-N16		2.36	5.47	1 NPT	1.81

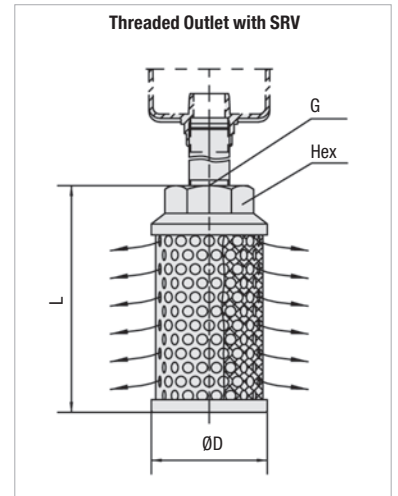

Return-Line Filters ■ Type RFB Flow Characteristics

The following characteristics are valid for mineral oils with a density of 0,85 kg/dm³ and the kinematic viscosity of 30 mm²/s (30cSt). The characteristics have been determined in accordance to ISO 3968. Multipass filter ratings have been obtained in accordance to ISO 16889. The housing pressure drop is directly proportional to the oil density. Contact STAUFF for details.

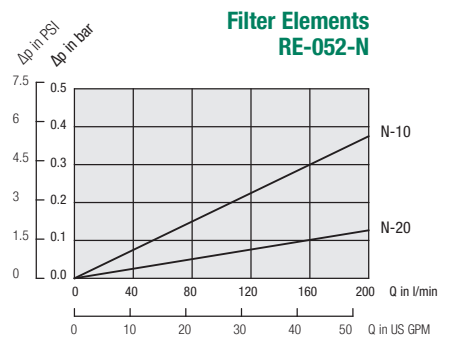
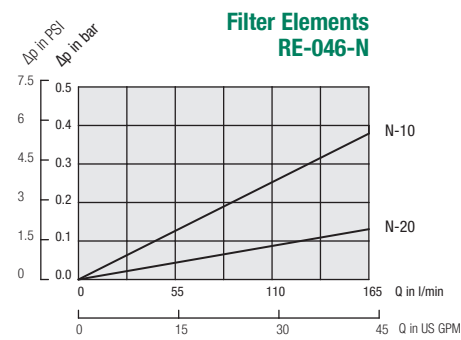
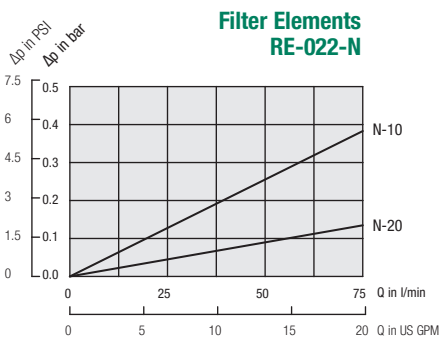
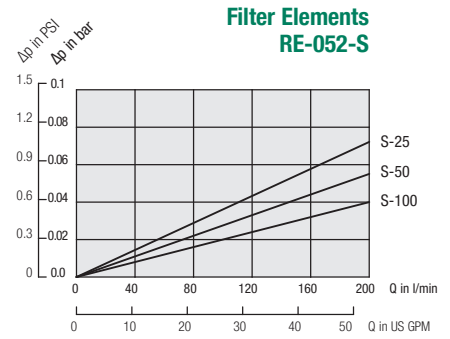
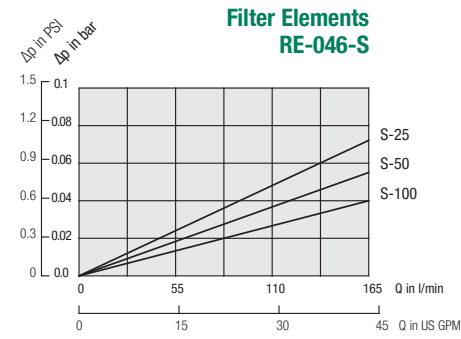
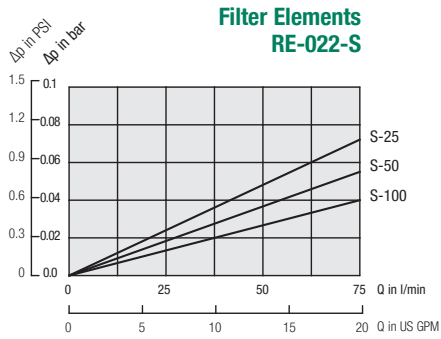
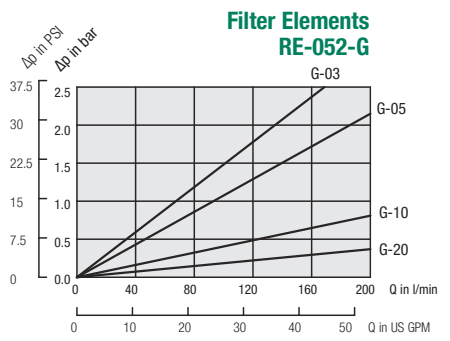
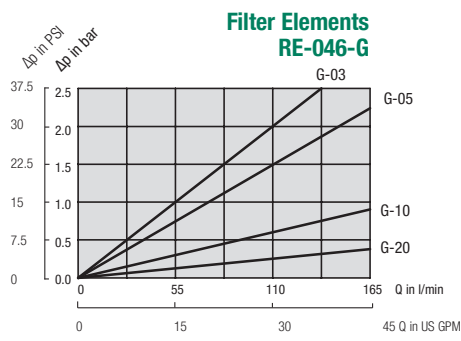
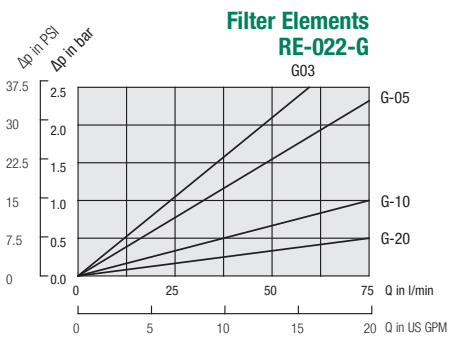
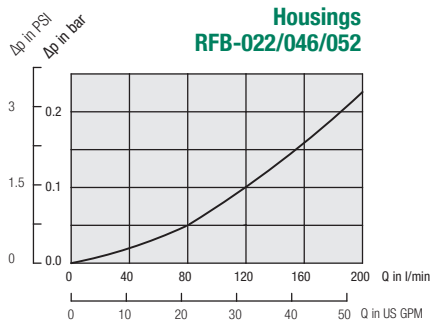

Checklist for the selection of filter housings

Please use the following Checklist as a guideline when preparing an enquiry for the selection of filter housings. Scan or copy the page from the catalogue, print and com-

plete it with as much information as possible, before sending it by email or fax to the closest STAUFF branch office. If possible, please also let us know the quantities required,

and if the enquiry is for a one-time or recurring demand. We look forward to hearing from you, and are always available for consultation, when required.

D

Information on the fluid in use					
Type of fluid	<input type="text"/>	Brand	<input type="text"/>	ISO designation	
Fluid viscosity	<input type="text"/>	<input type="checkbox"/>	mm ² /sec	<input type="checkbox"/>	cSt
Fluid temperature	<input type="text"/>	°C	<input type="checkbox"/>	°F	<input type="text"/>
			<input type="checkbox"/>	In cold condition	<input type="text"/>
					<input type="checkbox"/>
					In warm condition
Information on the filter housing					
Position in the hydraulic system	<input type="checkbox"/>	Suction line	<input type="checkbox"/>	Pressure line	<input type="checkbox"/>
					Return line
Operating pressure	<input type="text"/>	<input type="checkbox"/>	bar	<input type="checkbox"/>	PSI
Nominal flow	<input type="text"/>	<input type="checkbox"/>	l/min	<input type="checkbox"/>	US GPM
Valve	<input type="checkbox"/>	No, not required			
	<input type="checkbox"/>	Yes, the following type:	<input type="checkbox"/>	Bypass valve	<input type="checkbox"/>
			<input type="checkbox"/>	Non-return valve	<input type="checkbox"/>
			<input type="checkbox"/>	Reverse flow valve	<input type="checkbox"/>
			<input type="checkbox"/>	Multi-function valve	
Clogging indicator	<input type="checkbox"/>	No, not required			
	<input type="checkbox"/>	Yes, the following type:	<input type="checkbox"/>	Visual	<input type="checkbox"/>
			<input type="checkbox"/>	Electrical	<input type="checkbox"/>
			<input type="checkbox"/>	Visual-electrical	
Connection type and size	<input type="text"/>				
Sealing material	<input type="checkbox"/>	NBR (Buna®)	<input type="checkbox"/>	FKM (Viton®)	<input type="text"/>
					Other
Information on the filter element					
Filter media	<input type="checkbox"/>	Inorganic Glass Fibre	<input type="checkbox"/>	Polyester Fibre	<input type="checkbox"/>
			<input type="checkbox"/>	Cellulose Fibre	<input type="checkbox"/>
				Stainless Fibre	<input type="checkbox"/>
					Stainless Mesh
Micron rating	<input type="text"/>	µm			
Cleanliness level	<input type="text"/>	(to ISO 4406)			
Information on the application	<input type="text"/>				
Information on the ambient conditions	<input type="text"/>				
Additional information and requirements	<input type="text"/>				

Return-Line Filters ■ Type RFS / RFS-D



D

Product Description

STAUFF RFS and RFS-D Carbon Steel Return-Line Filters are designed as tank top or in-line filters. They are mounted directly on the tank top and if 100% of the system oil is filtered, they provide the optimum removal of contaminants from the system. This provides the pump with clean oil thus reducing contaminant generated wear. The filter bowl is designed with a connection, threaded or flanged, for extending the return oil beneath the surface thus preventing the entrainment of air. A high efficiency of contaminant removal is assured by using STAUFF RE Replacement Filter Elements. The high dirt-hold capacity of STAUFF Elements ensures a long service life and as a result reduced maintenance costs.

Technical Data
Construction

- Tank Top mounting or in-line mounting

Materials

- Filter Housing: Carbon Steel
- Sealings: NBR (Buna-N®)
FKM (Viton®)
EPDM (Ethylene Propylene Diene Monomer Rubber)
Other sealing materials on request

Port Connections

- BSP
- SAE flange 3000 PSI

Flow Rating

- Up to 1135 l/min / 300 US GPM

Operating Pressure

- Max. 25 bar / 365 PSI

Proof Pressure

- Min. 37,5 bar / 545 PSI

Temperature Range

- -20 °C ... +100 °C / -44 °F ... +212 °F
(Short term up to +110 °C / +230 °F)

Filter Elements

- Specifications see page 98

Media Compatibility

- Mineral oils, other fluids on request

Options and Accessories
Valve

- Bypass valve (integrated in the filter element) Opening pressure 3 bar \pm 0,3 bar / 43.5 PSI \pm 4.35 PSI
Other settings available on request

Clogging Indicators

- For clogging indicator types please see page 99

Return-Line Filters ■ Type RFS

D

RFS-045/070

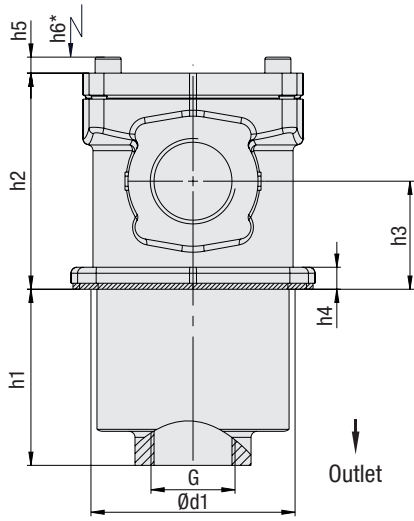

RFS-090/160

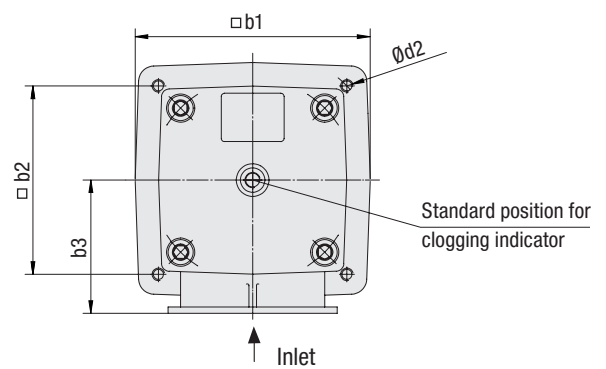
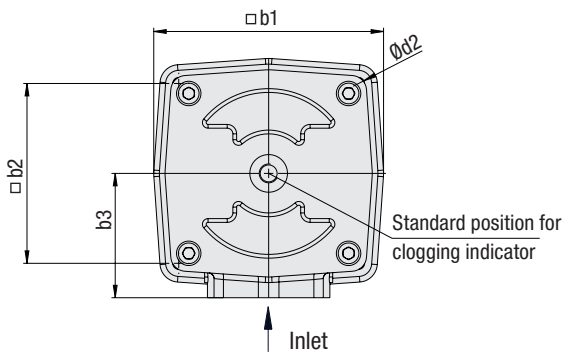
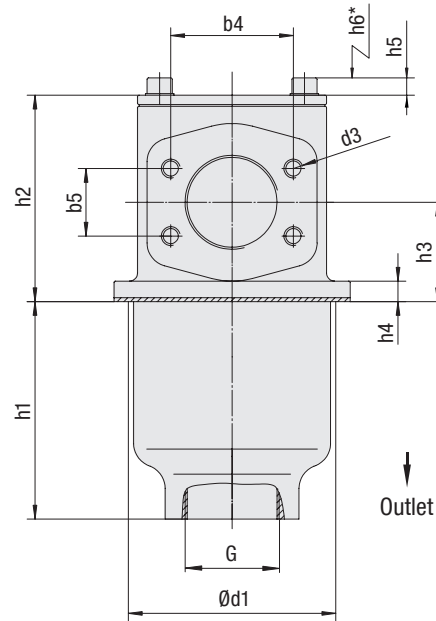

RFS-250/300

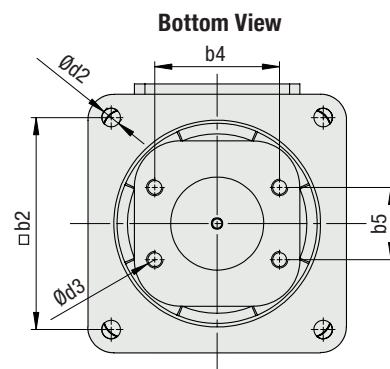
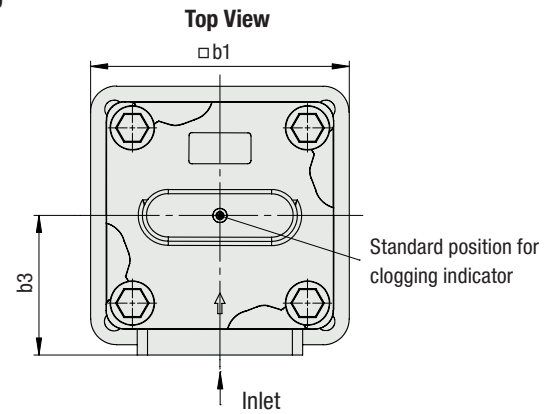
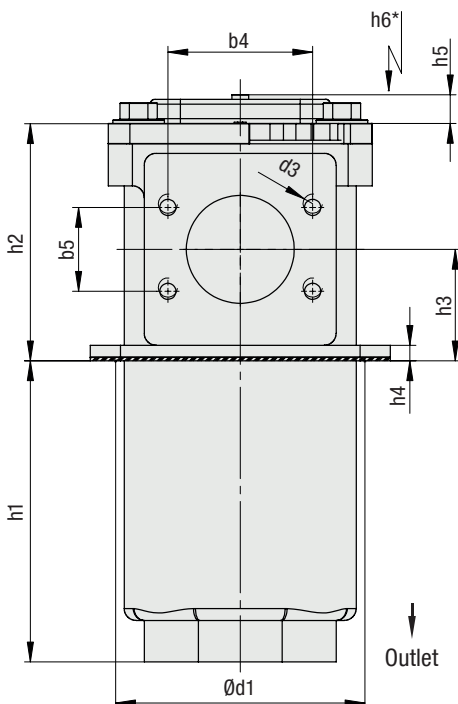

* recommended space for element change

RFS-D-090/160

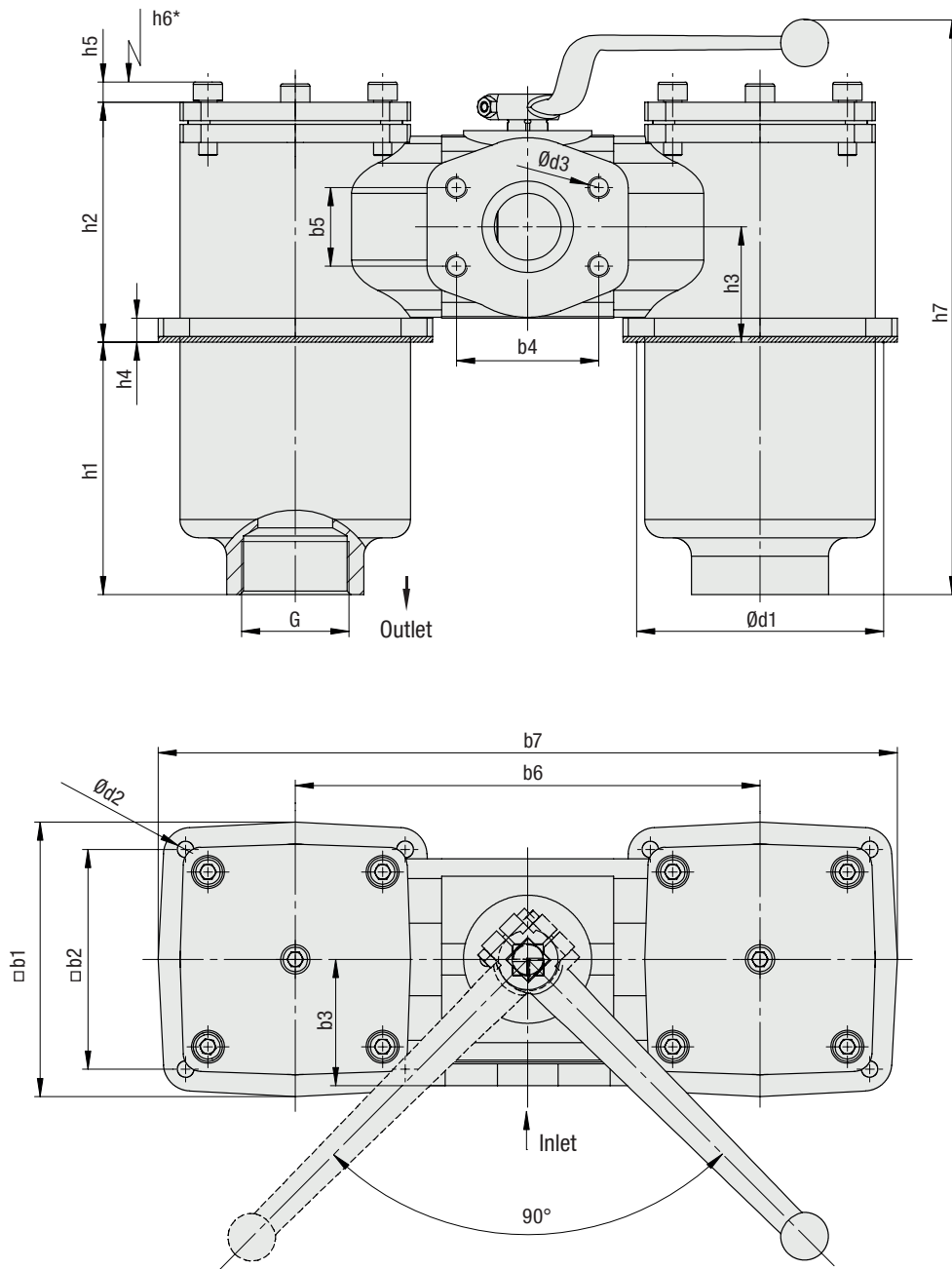

D

* recommended space for element change

Return-Line Filters ■ Type RFS-D

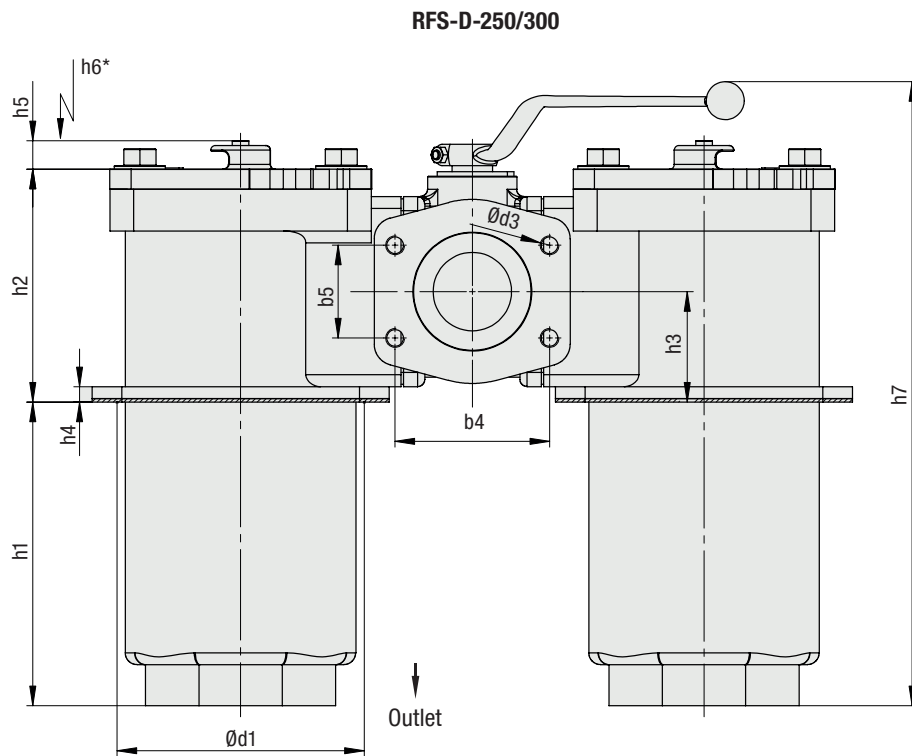

Top View

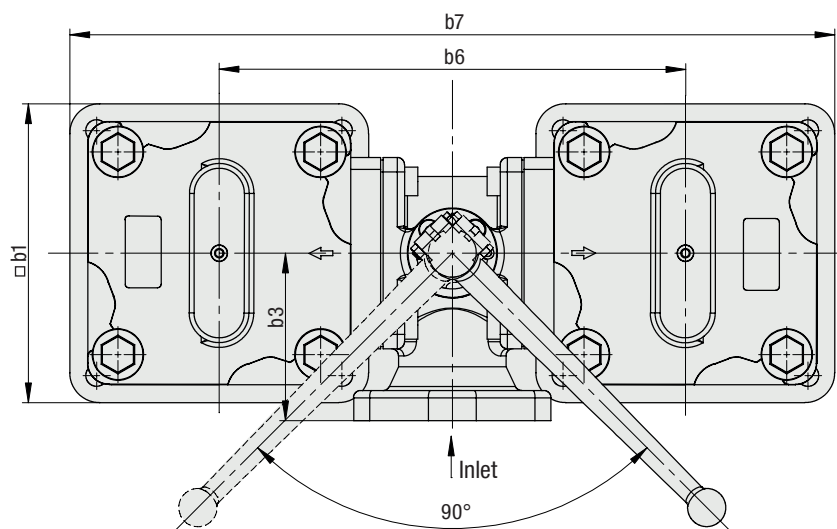

Bottom View

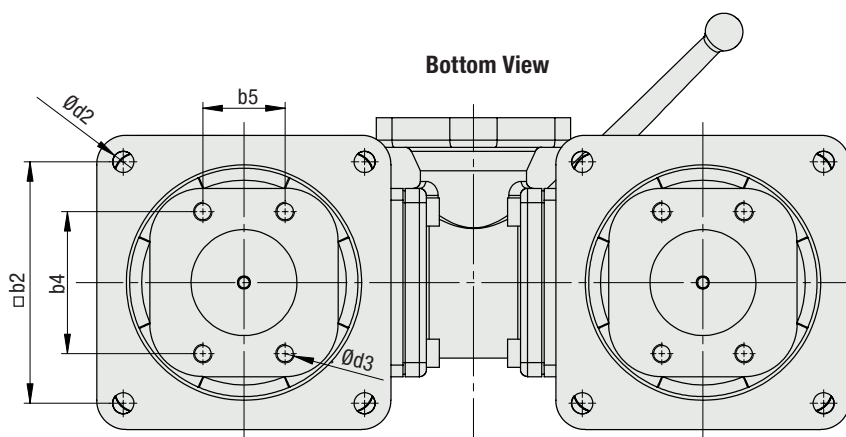

* recommended space for element change

Return-Line Filters ■ Type RFS / RFS-D

Thread Connection		Filter Size									
		RFS-045	RFS-070	RFS-090	RFS-D-090	RFS-160	RFS-D-160	RFS-250	RFS-D-250	RFS-300	RFS-D-300
Inlet	BSP	1-1/4	1-1/4	2	2	-	-	-	-	-	-
	SAE Flange	-	-	2	2	3	3	3-1/2	4	4	4
Outlet G	BSP	1-1/4	1-1/4	2	2	3	3	-	-	-	-
	SAE Flange	-	-	-	-	-	-	3-1/2	3-1/2	4	4

Dimensions (mm/in)	Filter Size									
	RFS-045	RFS-070	RFS-090	RFS-D-090	RFS-160	RFS-D-160	RFS-250	RFS-D-250	RFS-300	RFS-D-300
b1	122	122	150	150	196	196	255	255	255	255
	4.80	4.80	5.91	5.91	7.72	7.72	10.04	10.04	10.04	10.04
b2	95,5	95,5	120	120	155,5	155,5	205	205	205	205
	3.76	3.76	4.72	4.72	6.12	6.12	8.07	8.07	8.07	8.07
b3	66	66	85	69	110	100	135	140	145	140
	2.60	2.60	3.35	2.72	4.33	3.94	5.32	5.51	5.71	5.51
b4	-	-	77,8	77,8	106,4	106,4	120,7	130,2	130,2	130,2
	-	-	3.06	3.06	4.19	4.19	4.75	5.13	5.13	5.13
b5	-	-	42,9	42,9	61,9	61,9	69,5	77,8	77,8	77,8
	-	-	1.69	1.69	2.44	2.44	2.74	3.06	3.06	3.06
b6	-	-	-	254	-	330	-	390	-	410
	-	-	-	10	-	12.99	-	15.15	-	16.14
b7	-	-	-	404	-	525	-	640	-	660
	-	-	-	15.91	-	20.67	-	25.20	-	25.98
b8	-	-	-	-	-	-	-	120,7	-	130,2
	-	-	-	-	-	-	-	4.75	-	5.13
b9	-	-	-	-	-	-	-	69,5	-	77,8
	-	-	-	-	-	-	-	2.74	-	3.06
d1	102	102	135	135	180	180	208	208	208	208
	4.01	4.01	5.32	5.32	7.09	7.09	8.19	8.19	8.19	8.19
d2	6,4	6,4	9	9	13,5	13,5	17,5	17,5	17,5	17,5
	.25	.25	.35	.35	.53	.53	.69	.69	.69	.69
d3	-	-	M12	M12	M16	M16	M16	M16	M16	M16
	-	-	1/2-UNC	1/2-UNC	5/8-UNC	5/8-UNC	5/8 UNC	5/8 UNC	5/8 UNC	5/8 UNC
h1	88	147	138	138	243	243	251	251	332	332
	3.46	5.79	5.43	5.43	9.57	9.57	9.88	9.88	13.07	13.07
h2	108	108	131	131	167	167	198	198	241	241
	4.25	4.25	5.16	5.16	6.57	6.57	7.80	7.80	9.49	9.49
h3	54	54	63	63	84	84	93	93	121	121
	2.12	2.12	2.48	2.48	3.31	3.31	3.66	3.66	4.76	4.76
h4	11	11	13	13	13	13	13	13	13	13
	.43	.43	.51	.51	.51	.51	.51	.51	.51	.51
h5	8	8	12	12	12	12	24	24	24	24
	.31	.31	.47	.47	.47	.47	.95	.95	.95	.95
h6	130	130	180	180	320	320	350	350	460	460
	5.11	5.11	7.09	7.09	12.60	12.60	13.78	13.78	18.11	18.11
h7	-	-	-	314	-	450	-	525	-	630
	-	-	-	12.36	-	17.72	-	20.67	-	24.80

D

Return-Line Filter Housings / Complete Filters ■ Type RFS / RFS-D



① Type

Single Carbon Steel Return-Line Filter	RFS
Double Carbon Steel Return-Line Filter	RFS-D

② Group

Flow	Size
170 l/min / 45 US GPM (not for RFS-D)	045
240 l/min / 70 US GPM (not for RFS-D)	070
340 l/min / 90 US GPM	090
600 l/min / 160 US GPM	160
945 l/min / 250 US GPM	250
1135 l/min / 300 US GPM	300

Note: Exact flow will depend on the selected filter element.
For technical data please see pages 101 / 102.

③ Filter Material

Material	Max. Δp*collapse	Micron ratings available	Code
Without filter element	-	-	0
Inorg. glass fibre	25 bar / 363 PSI	3, 5, 10, 20	G
Stainless fibre	30 bar / 435 PSI	3, 5, 10, 20	A
Filter paper	10 bar / 145 PSI	10, 20	N
Stainless mesh	30 bar / 435 PSI	25, 50, 100, 200	S

Note: *Collapse/burst resistance as per ISO 2941.
Other materials on request.

④ Micron Rating

3 µm	03
5 µm	05
10 µm	10
20 µm	20
25 µm	25
50 µm	50
100 µm	100
200 µm	200

Note: Other micron ratings on request.

⑤ Sealing Material

NBR (Buna®)	B
FKM (Viton®)	V
EPDM	E

Note: Other sealing materials on request.

⑩ Design Code

Only for information	X
----------------------	----------

⑥ Connection Style

Connection Style	Thread Style	Group 045 / 070	Code	Group 090	Code	Group 160	Code	Group 250	Code	Group 250* / 300	Code
BSP	-	1-1/4	G20	2	G32	-	-	-	-	-	-
SAE Flange 3000 PSI	metric	-	-	2	C332M	3	C348M	3-1/2	C356M	4	C364M
SAE Flange 3000 PSI	UNC	-	-	2	C332U	3	C348U	3-1/2	C356U	4	C364U

* Note: Only for RFS-D-250.

⑦ Clogging Indicator

Without Clogging Indicator	0
Visual Clogging Indicator	V
Electrical Clogging Switch 42 V, NO	G42NO
Electrical Clogging Switch 42 V, NC	G42NC
Electrical Clogging Switch 110 V ... 230 V, two-way contact (only for Code W)	G230

⑧ Option Clogging Indicator G42NO, G42NC and G230

Plug connector	0
M12 x 1,5	M12
AMP plug	A
Deutsch plug	D
Rubber boot	S
90 degree Polyamide cap (only for Code G230)	W

⑨ Outlet Style

Connection Style	Thread Style	Group 045 / 070	Code	Group 090	Code	Group 160	Code	Group 250	Code	Group 300	Code
BSP	-	1-1/4	G20	2	G32	3	G48	-	-	-	-
SAE Flange 3000 PSI	metric	-	-	-	-	-	-	3-1/2	C356M	4	C364M
SAE Flange 3000 PSI	UNC	-	-	-	-	-	-	3-1/2	C356U	4	C364U

Filter Elements ■ Type RE

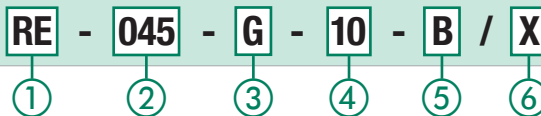

① Type

Filter Element Series	RE
-----------------------	-----------

② Group

According to filter housing	
-----------------------------	--

③ Filter Material

Material	Max. Δp*collapse	Micron ratings available	Code
Inorg. glass fibre	25 bar / 363 PSI	3, 5, 10, 20	G
Stainless fibre	30 bar / 435 PSI	3, 5, 10, 20	A
Filter paper	10 bar / 145 PSI	10, 20	N
Stainless mesh	30 bar / 435 PSI	25, 50, 100, 200	S

Note: *Collapse/burst resistance as per ISO 2941.
Other materials on request.

④ Micron Rating

3 µm	03
5 µm	05
10 µm	10
20 µm	20
25 µm	25
50 µm	50
100 µm	100
200 µm	200

Note: Other micron ratings on request.

⑤ Sealing Material

NBR (Buna®)	B
FKM (Viton®)	V
EPDM	E

Note: Other sealing materials on request.

⑥ Design Code

Only for information	X
----------------------	----------

Return-Line Filters ■ Type RFS / RFS-D

Electrical Clogging Switch

The switch is used where an electrical signal is needed to indicate when the element needs to be changed. The switch can turn on a light, or shut the machine down, or any further function controlled by an electric signal. The switching pressure is 2,5 bar / 36.25 PSI and this allows the element to be changed before the bypass setting of 3 bar / 43.5 PSI is reached.

Standard type with plug connector and rubber cap. Available with DEUTSCH DT04-2P plug (industrial standard), AMP Junior Timer plug (industrial standard) and five-pin circular connector M12, A-coded, according to IEC 61076-2-101.

Technical Data

	Limit-Switch G42NO+NC	Limit-Switch G230
Switching Capacity	100 VA	1000 VA
Voltage	10...42 VAC/DC	10...250 VAC/DC
Current		10mA...4A
Switching Accuracy		± 0,5 bar at room temp. and new state
Switching Frequency		200/min
max. Pressure Ramp Rate		≤ 1 bar/ms
Degree of Protection	IP65 (plug type S and W), IP67 (plug type M12, A, D)	
Temperature Range	-30°C ... +100°C	-40°C ... +100°C

Order Code

Limit-Switch - **G42NO** - **S** - **M10** - **B2.5**

①

②

③

④

⑤

① Type

Limit-Switch

② Connector Type

Electrical Clogging Switch 10 V ... 42 V, NO	G42NO
Electrical Clogging Switch 10 V ... 42 V, NC	G42NC
Electrical Clogging Switch 10 V ... 250 V, two-way contact (only for Plug Type W)	G230

③ Plug Type

M12 Five-Pin Connector according to IEC 61076-2-101	M12
AMP-Junior-Timer Plug	A
DEUTSCH Plug DT04-2P	D
Rubber boot	S
90 degree Polyamide cap (only for Connector Type G230)	W

④ Thread Type

 M10 x 1 con. **M10**

⑤ Pressure Setting

 2,5 bar / 36.3 PSI **B2.5**

Dimensions Plug Type

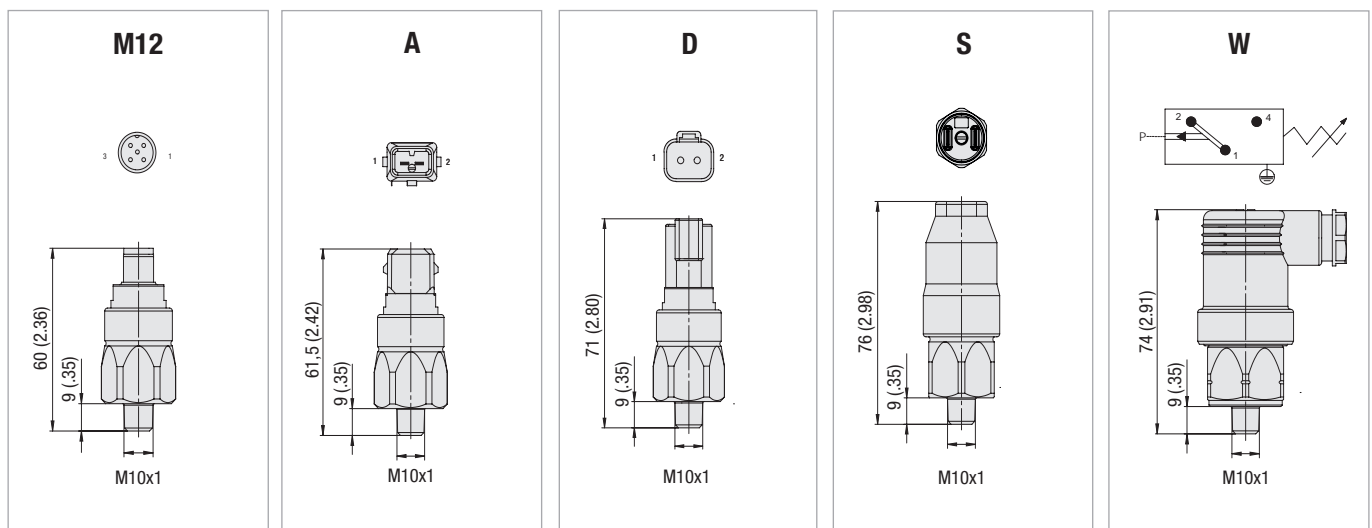

Note: The customer / user carries the responsibility for the electrical connection.

Return-Line Filters ▪ Type RFS / RFS-D

Visual Clogging Indicator

The gauge visually displays the degree of contamination of the element.
The colored segments allow quick visual checking.

green	0 ... 2,5 bar / 0 ... 36.25 PSI	Element has service life left
yellow	2,5 ... 3,0 bar / 36.25 ... 43.5 PSI	Element is contaminated and should be changed
red	>3,0 bar / >43.5 PSI	Bypass valve open, unfiltered oil passing to tank

Order Codes

SPG-C-040-00004-02-P-M10-402922

①

① Type

Visual Clogging Indicator **SPG-C-040-00004-02-P-M10-402922**

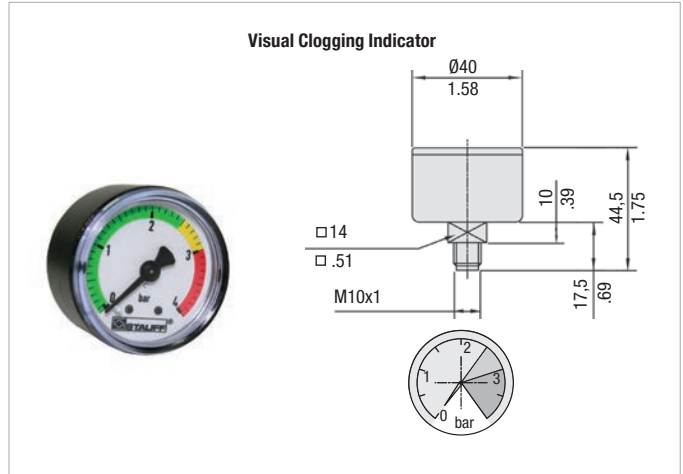

Leakage Oil Connection

Seal or case drain lines can be connected to the filter through either of the clogging indicator ports providing that the leakage oil can accept a pressure of 3 bar / 43.5 PSI. It ensures that no unfiltered oil can return to the reservoir.

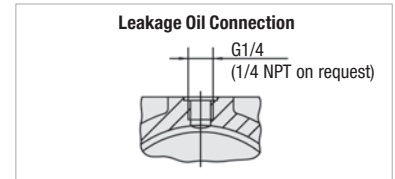

Filter Bowl with Threaded Connection and Diffuser

Diffusers mounted to the filter bowl minimise foaming and reduce noise of high Return-Line flows. For further details on STAUFF Diffusers please refer to the Catalogue No. 10 - Hydraulic Accessories.
Attention: Connection pipe not included in scope of delivery!

Size SRV	for Return-Line Filter Size	Dimensions (mm/in)		Thread G	Hex
		øD	L		
SRV-227-G24	RFS-250	84	200	G1-1/2	60
SRV-227-N24		3.31	7.87	1-1/2 NPT	2.36
SRV-454-G32	RFS-250	84	260	G2	70
SRV-454-N32		3.31	10.24	2 NPT	2.76
SRV-950-G24	RFS-250	148	272	G3	100
SRV-950-N24		5.83	10.71	3 NPT	3.94

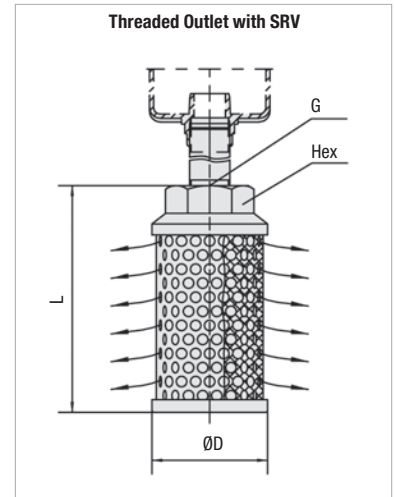

Return-Line Filters ■ Type RFS Flow Characteristics

The following characteristics are valid for mineral oils with a density of 0,85 kg/dm³ and the kinematic viscosity of 30 mm²/s (30cSt). The characteristics have been determined in accordance to ISO 3968. Multipass filter ratings have been obtained in accordance to ISO 16889. The housing pressure drop is directly proportional to the oil density. Contact STAUFF for details.

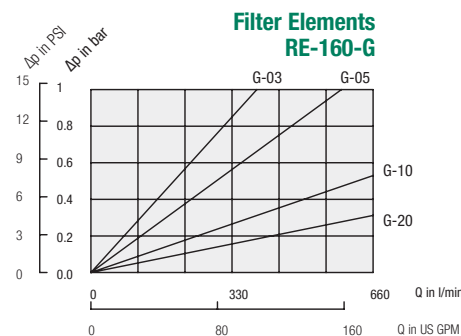
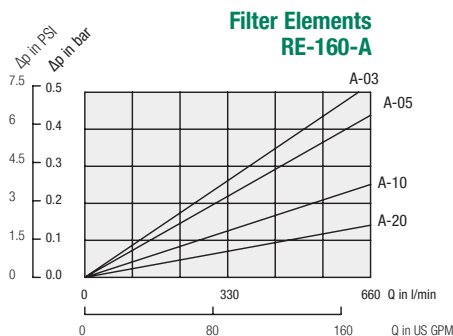
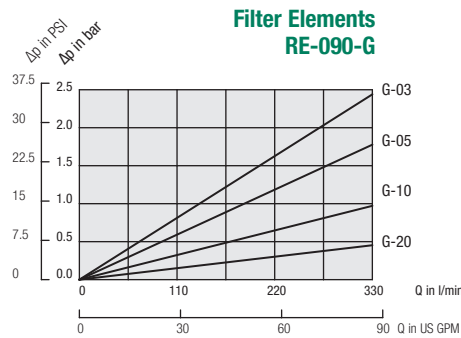
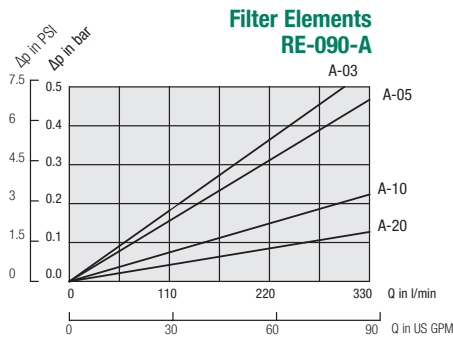
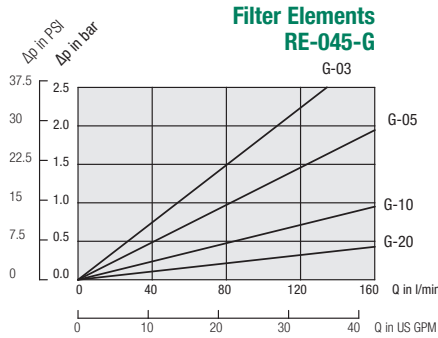
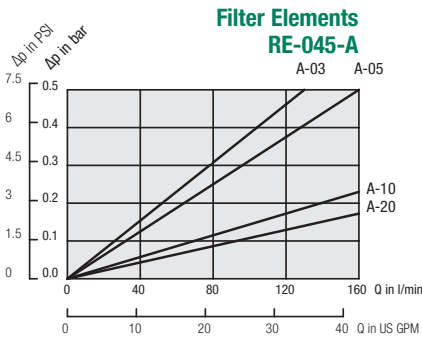
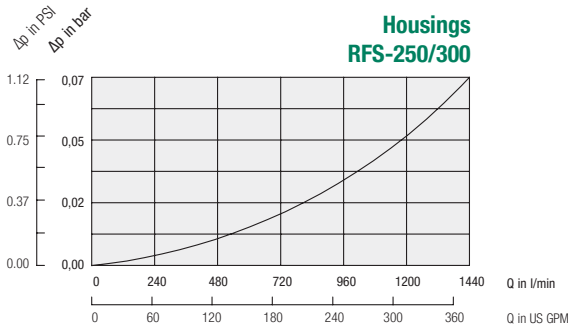
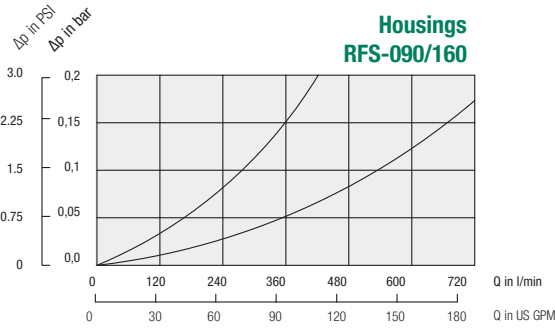
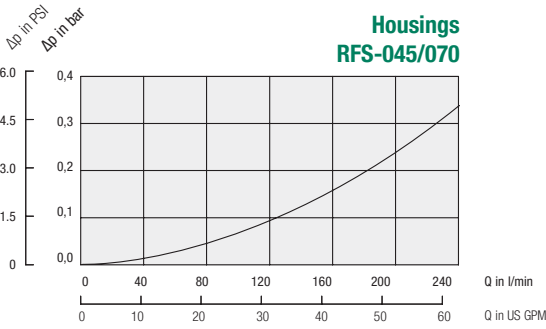

D

Return-Line Filters - Type RFS Flow Characteristics

The following characteristics are valid for mineral oils with a density of 0,85 kg/dm³ and the kinematic viscosity of 30 mm²/s (30cSt). The characteristics have been determined in accordance to ISO 3968. Multipass filter ratings have been obtained in accordance to ISO 16889. The housing pressure drop is directly proportional to the oil density. Contact STAUFF for details.

D

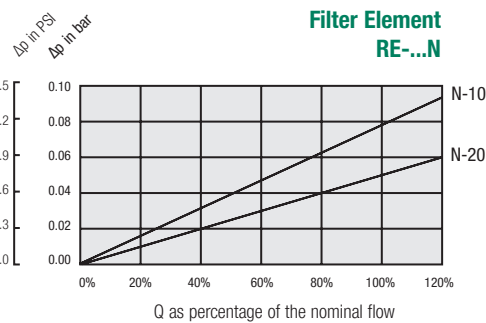
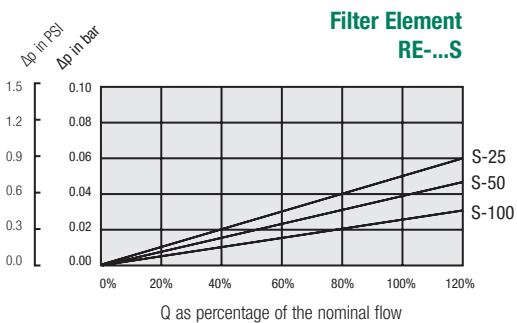
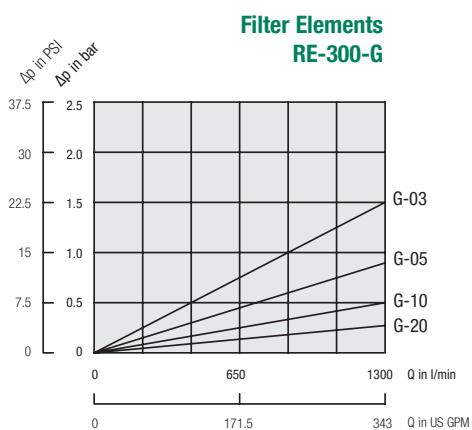
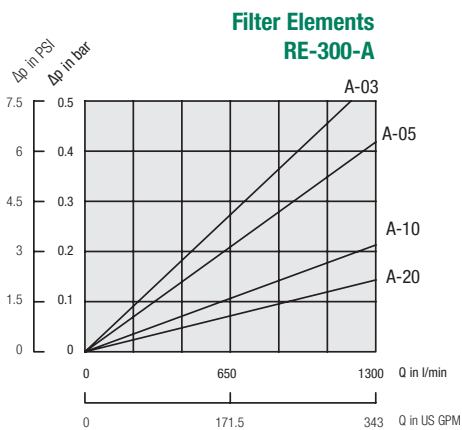
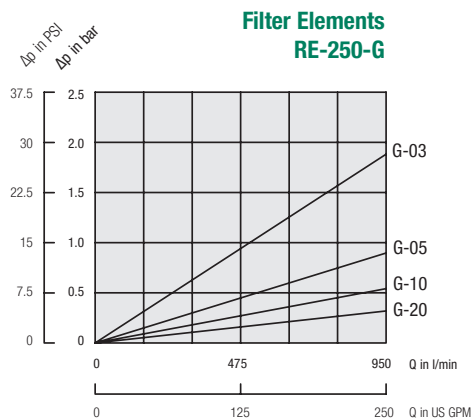
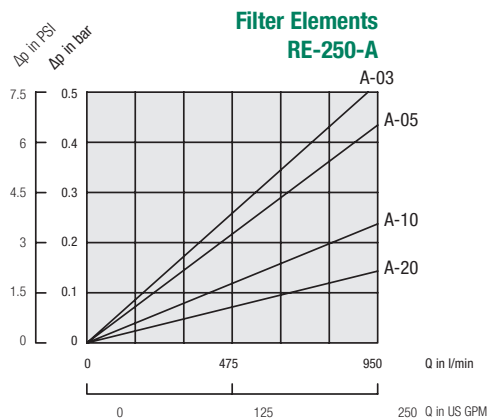

Return-Line Filters ■ Type RTF-10/15/25



D

Product Description

STAUFF RTF-10/15/25 Return-Line Filters are designed as tank top filters with a maximum operating pressure of 3,4 bar / 49 PSI.

Technical Data
Construction

- Tank Top flange mounting

Materials

- Filter head: Aluminium
- Filter bowl: Polyamide
- Sealings: NBR (Buna-N®)
FKM (Viton®)
Other sealing materials on request

Port Connections

- BSP
- NPT
- SAE O-ring thread

Flow Rating

- Up to 95 l/min / 25 US GPM

Operating Pressure

- Max. 3,4 bar / 49 PSI

Burst Pressure

- Min. 10 bar / 145 PSI

Temperature Range

- -20 °C ... +100 °C / -44 °F ... +212 °F
(Short term up to +110 °C / +230 °F)

Filter Elements

- Specifications see page 106

Media Compatibility

- Mineral oils, other fluids on request

Options and Accessories
Valve

- Bypass valve: Opening pressure 1,7 bar / 25 PSI
(integrated in the filter element)
Other settings available on request

Clogging Indicators

- For clogging indicator types please see page 125

Return-Line Filters ■ Type RTF-10/15/25

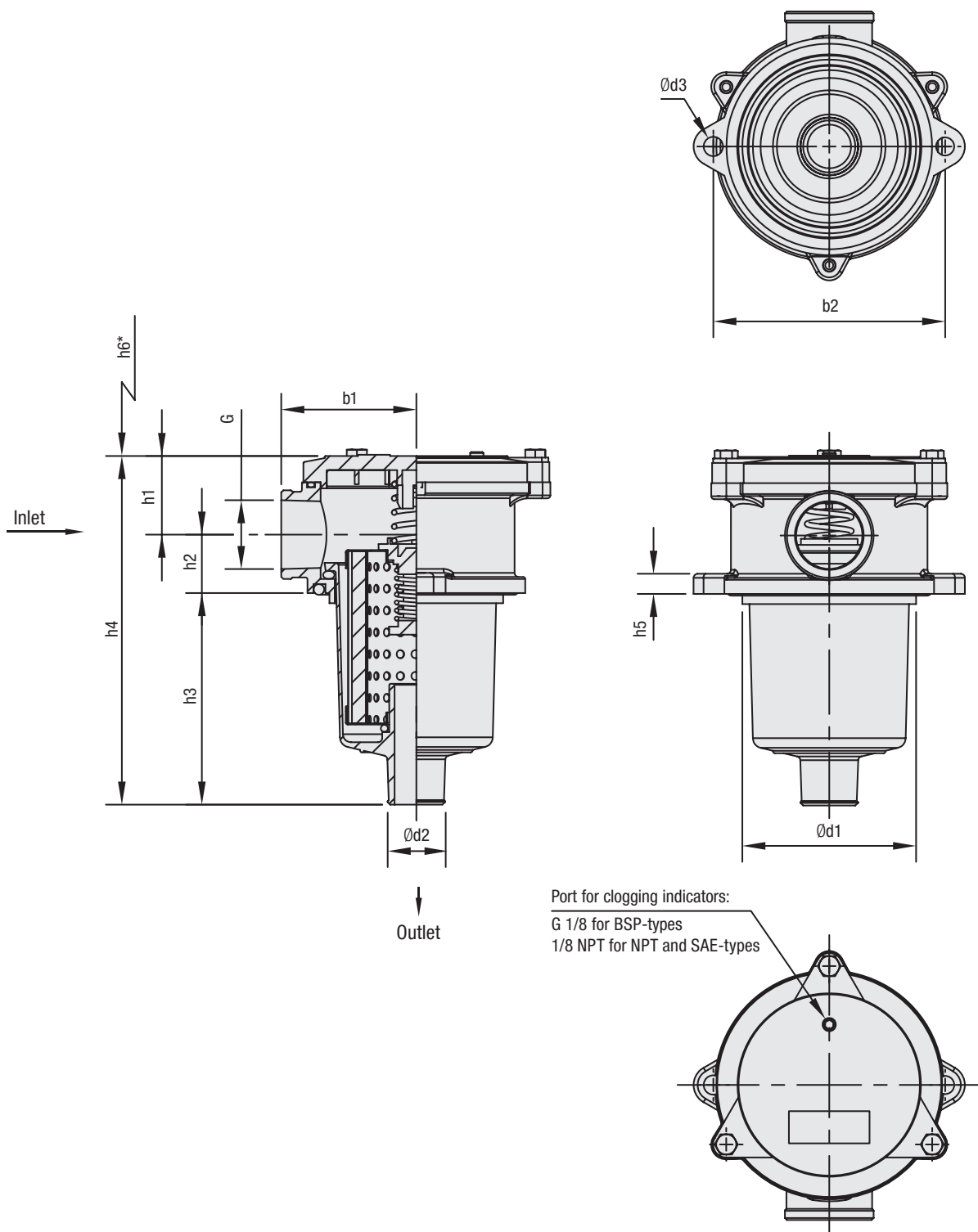

* recommended space for element change

Return-Line Filters ■ Type RTF-10/15/25

Thread Connection G	Filter Size RTF		
	10	15	25
BSP	1/2	1	1
NPT	1/2	1	1
SAE O-ring	-	1-5/16-12	1-5/16-12

Dimensions (mm/in)	Filter Size RTF		
	10	15	25
h1	26	34	34
	1.02	1.34	1.34
h2	21	29	29
	.83	1.14	1.14
h3	89	103	149
	3.50	4.05	5.87
h4	136	166	212
	5.35	6.53	8.35
h5	8	10	10
	.32	.39	.39
h6	110	130	175
	4.33	5.12	6.89
b1	50	67	67
	1.97	2.64	2.64
b2	90	115	115
	3.54	4.52	4.52
d1	66	86	86
	2.60	3.39	3.39
d2	24	28	28
	.94	1.10	1.10
d3	7	9	9
	.28	.35	.35
Weight (kg/lbs)	0,45	0,9	1
	1	2	2.2

Return-Line Filter Housings / Complete Filters ■ Type RTF-10/15/25



① Type

Return-Line Filter RTF

② Group

Flow	Size
38 l/min / 10 US GPM	10
57 l/min / 15 US GPM	15
95 l/min / 25 US GPM	25

Note: Exact flow will depend on the selected filter element.
For technical data please see pages 123 / 124.

③ Filter Material

Material	Max. Δp*collapse	Micron ratings available	Code
Without filter element	-	-	0
Inorg. glass fibre	3 bar / 43.5 PSI	10, 25	G
Filter paper	3 bar / 43.5 PSI	10, 25	D

*Note: Collapse/burst resistance as per ISO 2941
Other materials on request

④ Micron Rating

10 µm	10
25 µm	25

Note: Other micron ratings on request

⑤ Sealing Material

NBR (Buna®) **B**
 FKM (Viton®) **V**
 Note: Other sealing materials on request

⑥ Connection Style

Connection Style	Group	Code	Group		Code
			10	25 and 15	
BSP	1/2	G08	1		G16
NPT	1/2	N08	1		N16
SAE O-ring Thread	-	-	1-5/16-12		U16

⑦ Clogging Indicator

Without clogging indicator **0**
 Visual clogging indicator **V**
 Electrical clogging indicator **E**
 Note: See page 125 for more details on indicator ports and types.

⑧ Design Code

Only for information **X**

Filter Elements ■ Type RTE

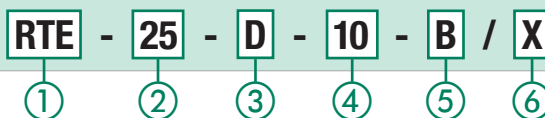

① Type

Filter Element Series RTE

② Group

According to filter housing

③ Filter Material

Material	Max. Δp*collapse	Micron ratings available	Code
Inorg. glass fibre	3 bar / 43.5 PSI	10, 25	G
Filter paper	3 bar / 43.5 PSI	10, 25	D

* Note: Collapse/burst resistance as per ISO 2941
Other materials on request

④ Micron Rating

10 µm	10
25 µm	25

Note: Other micron ratings on request

⑤ Sealing Material

NBR (Buna®) **B**
 FKM (Viton®) **V**
 Note: Other sealing materials on request

⑥ Design Code

Only for information **X**

Return-Line Filters ■ Type RTF-20



D

Product Description

STAUFF RTF-20 Return-Line Filters are designed as tank top filters with a maximum operating pressure of 10 bar / 145 PSI and flow rates up to 115 l/min / 30 US GPM. The filter bowl is designed to return the oil beneath the surface thus preventing entrainment of air. RTF-20 series compact design and integral breather make them ideal for mobile hydraulic applications.

Technical Data
Construction

- Tank Top flange mounting

Materials

- Filter head: Aluminium
- Filter bowl & cap: Polyamide
- Sealings: NBR (Buna-N®)
FKM (Viton®)
Other sealing materials on request

Port Connections

- BSP
- NPT
- SAE O-ring thread

Flow Rating

- Up to 115 l/min / 30 US GPM

Operating Pressure

- Max. 10 bar / 145 PSI

Burst Pressure

- Min. 30 bar / 435 PSI

Temperature Range

- -20 °C ... +100 °C / -44 °F ... +212 °F
(Short term up to +110 °C / +230 °F)

Integrated Breather

- Filter paper 10 µm
- Filter paper 40 µm

Filter Elements

- Specifications see page 110

Media Compatibility

- Mineral oils, other fluids on request

Options and Accessories
Valve

- Bypass valve: Opening pressure 1,7 bar / 25 PSI
(integrated in the filter element) Other settings available on request

Clogging Indicators

- For clogging indicator types please see page 125

Return-Line Filters ■ Type RTF-20

D

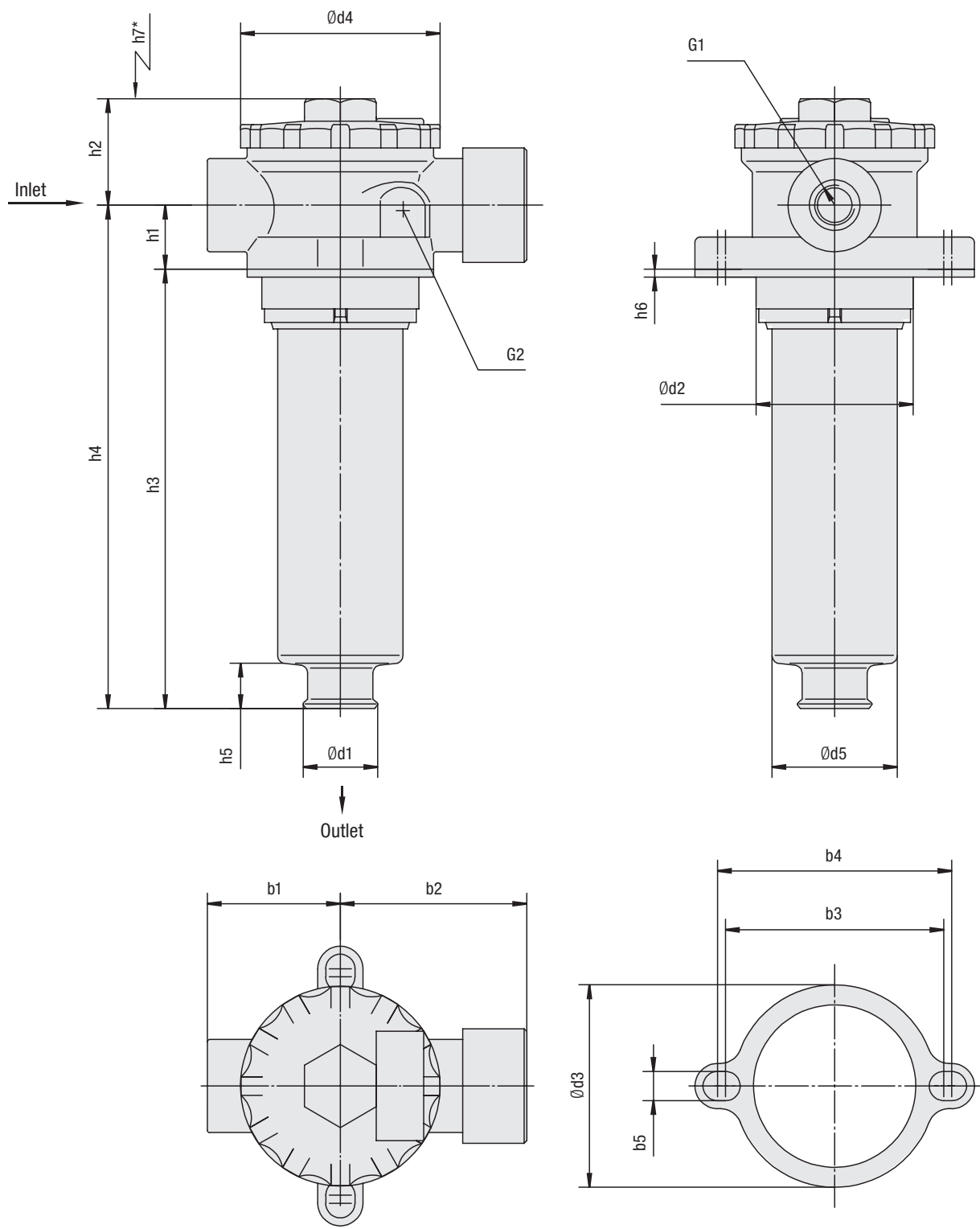

* recommended space for element change

Return-Line Filters ■ Type RTF-20

Thread Connection G1	Filter Size RTF 020	
BSP	1/2	3/4
NPT	1/2	3/4
SAE Thread	3/4-16	

Dimensions (mm/in)	Filter Size RTF 020	
b1	50	
	1.97	
b2	70	
	2.76	
b3	82	
	3.23	
b4	88	
	3.46	
b5	11	
	.43	
d1	28	
	1.10	
d2*	Min. 60 / Max. 63	
	Min. 2.36 / Max. 2.48	
d3	77	
	3.03	
d4	75	
	2.95	
d5	48	
	1.89	
h1	24	
	.94	
h2	37,5	
	1.48	
h3	178	
	7.01	
h4	202	
	7.95	
h5	16	
	.63	
h6	2	
	.07	
h7	210	
	8.27	
G2	G1/8 or 1/8 NPT	

* recommended diameter for mounting hole

D

Return-Line Filter Housings / Complete Filters ■ Type RTF-20

RTF - **20** - **D** - **10** - **B** - **G08** - **V** - **L10** - **D** / **X**

① ② ③ ④ ⑤ ⑥ ⑦ ⑧ ⑨ ⑩

① Type

Return-Line Filter **RTF**

② Group

Flow **Size**
115 l/min / 30 US GPM **20**Note: Exact flow will depend on the selected filter element.
For technical data please see pages 123 / 124..

③ Filter Material

Material	Max. Δp*collapse	Micron ratings available	Code
Without filter element	-	-	0
Inorg. glass fibre	25 bar / 363 PSI	10, 20	G
Filter paper	10 bar / 145 PSI	10	D

*Note: Collapse/burst resistance as per ISO 2941
Other materials on request

④ Micron Rating

10 μm **10**
20 μm **20**

Note: Other micron ratings on request

⑤ Sealing Material

NBR (Buna®) **B**
FKM (Viton®) **V**

Note: Other sealing materials on request

⑥ Connection Style

Connection Style	Thread	Code
BSP	1/2	G08
BSP	3/4	G12
NPT	1/2	N08
NPT	3/4	N12
SAE O-ring Thread	3/4-16	U08

⑦ Clogging Indicator

No clogging indicator **0**
Visual clogging indicator **V**
Electrical clogging indicator **E**Note: See page 125 for more details on
indicator ports and types.

⑧ Breather

10 μm Filter Paper **L10**
40 μm Filter Paper **L40**

⑨ Dipstick

Without dipstick (standard) **none**
With dipstick **D**

⑩ Design Code

Only for information **X**

Filter Elements ■ Type RTE

RTE - **20** - **D** - **10** - **B** / **X**

① ② ③ ④ ⑤ ⑥

① Type

Filter Element Series **RTE**

② Group

According to filter housing

③ Filter Material

Material	Max. Δp*collapse	Micron ratings available	Code
Inorg. glass fibre	25 bar / 363 PSI	10, 20	G
Filter paper	10 bar / 145 PSI	10	D

*Note: Collapse/burst resistance as per ISO 2941
Other materials on request

④ Micron Rating

10 μm **10**
20 μm **20**

Note: Other micron ratings on request

⑤ Sealing Material

NBR (Buna®) **B**
FKM (Viton®) **V**

Note: Other sealing materials on request

⑥ Design Code

Only for information **X**

Air Filter Elements ■ Type RTEA

REA-RTF - **20** - **L** - **10** - **B** / **X**

① ② ③ ④ ⑤ ⑥

① Type

Air Filter Element Series **REA-RTF**

② Group

Air filter for RTF-20 **20**

③ Filter Material

Filter Paper **L**
Note: Other materials on request

④ Micron Rating

10 μm **10**
Note: Other micron ratings on request

⑤ Sealing Material

NBR (Buna®) **B**
Note: Other sealing materials on request

⑥ Design Code

Only for information **X**

Return-Line Filters ■ Type RTF-40



D

Product Description

STAUFF RTF-40 Return-Line Filters are designed as tank top filters with a maximum operating pressure of 6,9 bar / 100 PSI. The filter bowl is designed to return the oil beneath the surface thus preventing entrainment of air.

Technical Data
Construction

- Tank Top flange mounting

Materials

- Filter head: Aluminium
- Filter bowl: Bowl length 1: Polyamide
Bowl length 2: Steel
- Sealings: NBR (Buna-N®)
Other sealing materials on request

Port Connections

- BSP
- NPT
- SAE O-ring thread
- SAE flange

Flow Rating

- Up to 378 l/min / 100 US GPM

Operating Pressure

- Max. 6,9 bar / 100 PSI

Temperature Range

- -25 °C ... +95 °C / -13 °F ... +203 °F

Filter Elements

- RTE-47 with integrated bypass valve, single stack length
- RTE-48 bypass valve integrated in the filter head, equivalent to the HF-4 elements, single and double stack lengths
- RTE-49 bypass valve integrated in the filter head, single and double stack lengths
- Specifications see page 114

Media Compatibility

- Mineral oils, other fluids on request

Options and Accessories
Valve

- Bypass valve: Opening pressures 1 bar / 14.5 PSI \pm 10 % or
1,7 bar / 25 PSI \pm 10 %
RTF-47: Bypass intergrated in the filter element
RTF-48/49: Bypass integrated in the filter head

Clogging Indicators

- For clogging indicator types please see page 125

Return-Line Filters ▪ Type RTF-40

D

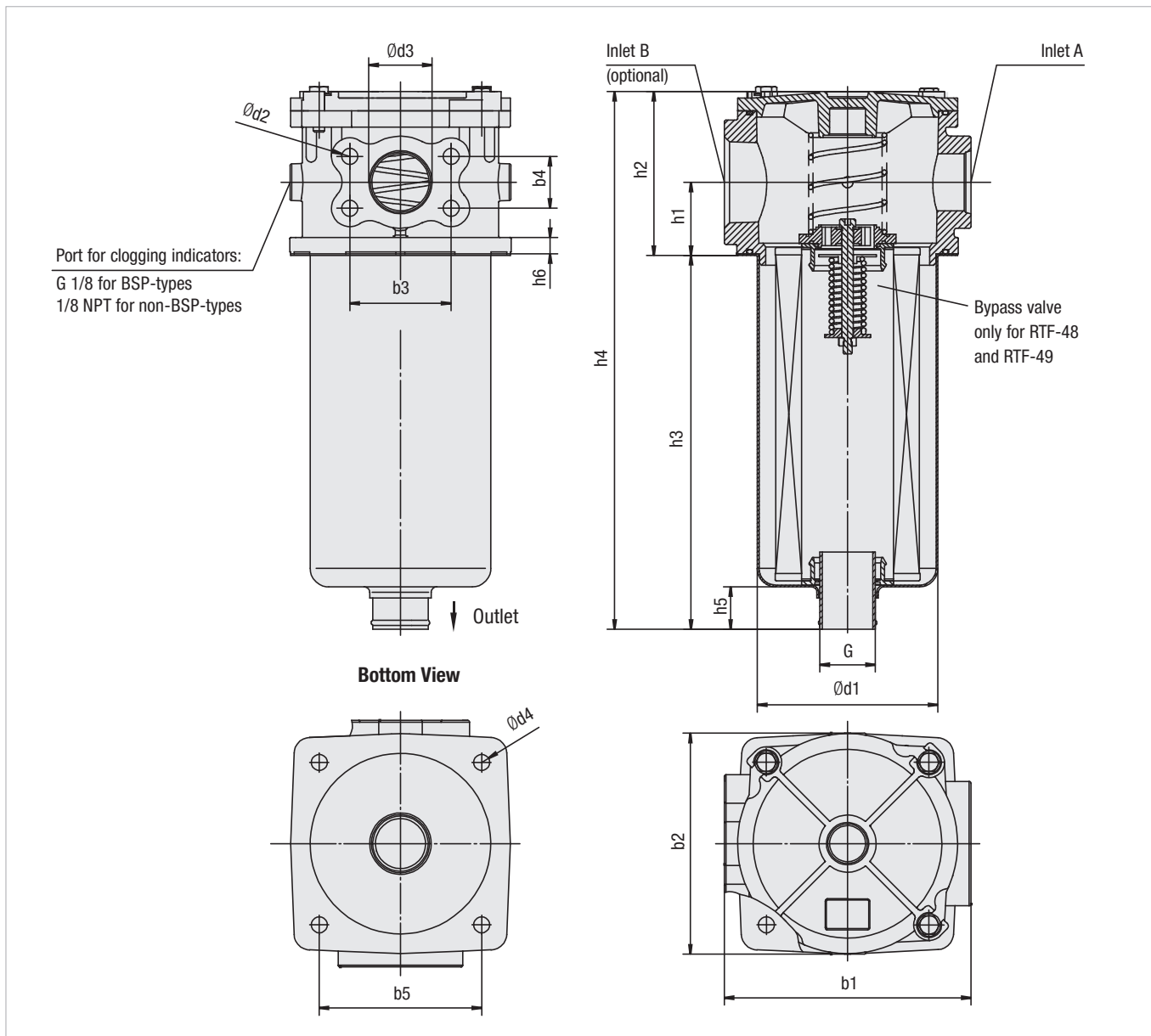

Filter Elements ▪ Types RTE-47 / RTE-48 / RTE-49

RTE-47

- with integrated bypass valve
- single stack length

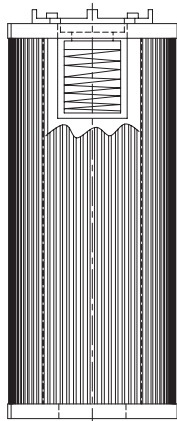

RTE-48

- bypass valve integrated in the filter head
- equivalent to the HF-4 elements
- single and double stack lengths

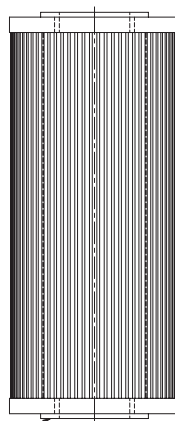

Seal: NBR (Buna®)

RTE-49

- bypass valve integrated in the filter head
- single and double stack lengths

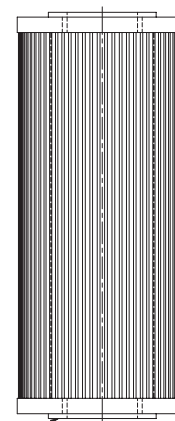

Seal: NBR (Buna®)

Return-Line Filters ■ Type RTF-40

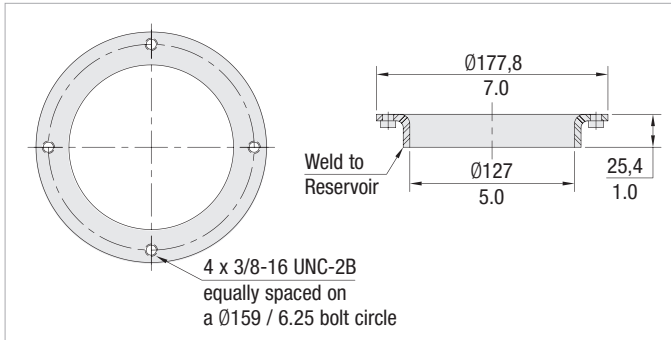
RTF-40 Series Weld Ring WR-40

The WR-40 weld ring is welded directly to the hydraulic reservoir, eliminating the need for drilling and tapping mounting holes in the reservoir.

Material: Carbon Steel

Thread Connection Combinations	Filter Size RTF			
	4...S1		4...S2	
	Inlet A	Inlet B	Inlet A	Inlet B
BSP	1-1/4 and 1-1/2 SAE Flange	None	1-1/4 and 1-1/2 SAE Flange	None
BSP	1-1/4 and 1-1/2 SAE Flange	1-1/4	1-1/4 and 1-1/2 SAE Flange	1-1/4
NPT	1-1/4 and 1-1/2 SAE Flange	None	1-1/4 and 1-1/2 SAE Flange	None
NPT	1-1/4 and 1-1/2 SAE Flange	1-1/4	1-1/4 and 1-1/2 SAE Flange	1-1/4
NPT	1-1/2	None	1-1/2	None
NPT	1-1/2	1-1/4	1-1/2	1-1/4
NPT	1-1/2	1-1/2	1-1/2	1-1/2
SAE	1-5/8-12	None	1-5/8-12	None
SAE	1-5/8-12	1-5/8-12	1-5/8-12	1-5/8-12
SAE	1-5/8-12	1-7/8-12	1-5/8-12	1-7/8-12
SAE	1-5/8-12	2-1/2-12	1-5/8-12	2-1/2-12
SAE	1-7/8-12	1-7/8-12	1-7/8-12	1-7/8-12
Combination SAE & NPT	1-5/8-12	2	1-5/8-12	2

Dimensions (mm/in)	Filter Size RTF	
	4...S1	4...S2
h1	50 1.97	50 1.97
h2	112 4.41	112 4.41
h3	263 10.35	475 18.70
h4	385 15.16	587 23.11
h5	21 .83	38 1.50
h6	11 .43	11 .43
b1	170 6.70	170 6.70
b2	152 5.98	152 5.98
b3	69.9 2.75	69.9 2.75
b4	35.6 1.40	35.6 1.40
b5	112 4.41	112 4.41
d1	122 4.80	126 4.96
d2	M12 or 1/2-13 UN	M12 or 1/2-13 UN
d3	38,1 1.50	38,1 1.50
d4	11 .43	11 .43
G	G1-1/2 or 1-1/2 NPT	G1-1/2 or 1-1/2 NPT

Return-Line Filter Housings / Complete Filters ■ Type RTF-40

RTF - **48** - **D** - **10** - **B** - **G20+C324M/G20** - **B1** - **S2** - **V** / **X**

① ② ③ ④ ⑤ ⑥ ⑦ ⑧ ⑨ ⑩

① Type

Return-Line Filter **RTF**

② Group

Flow	Size
190 l/min / 50 US GPM	47
190 l/min / 50 US GPM	48
190 l/min / 50 US GPM	49

Note: Exact flow will depend on the selected filter element.

For technical data please see pages 123 / 124.

For element length 2 (only RTF-48 / RTF-49) please double relating flow values.

③ Filter Material

Material	Max. Δp^* collapse	Micron ratings available	Code
Without filter element	-	-	0
Inorg. glass fibre	10 bar / 145 PSI	3, 5, 10, 25	G
Filter paper	10 bar / 145 PSI	10, 25	D

*Note: Collapse/burst resistance as per ISO 2941
Other materials on request

④ Micron Rating

3 μ m	03
5 μ m	05
10 μ m	10
25 μ m	25

Note: Other micron ratings on request

⑤ Sealing Material

NBR (Buna®) **B**
Note: Other sealing materials on request

⑥ Connection Style

Connection Style	Group		Code
	Port A	Port B	
BSP	1-1/4 and 1-1/2 SAE Flange	None	G20+C324M/O
	1-1/4 and 1-1/2 SAE Flange	1-1/4	G20+C324M/G20
NPT	1-1/4 and 1-1/2 SAE Flange	None	N20+C324M/O
	1-1/4 and 1-1/2 SAE Flange	1-1/4	N20+C324M/N20
NPT	1-1/2	None	N24/O
NPT	1-1/2	1-1/4	N24/N20
NPT	1-1/2	1-1/2	N24/N24
SAE	1-5/8-12	None	U20/O
SAE	1-5/8-12	1-5/8-12	U20/U20
SAE	1-5/8-12	1-7/8-12	U20/U24
SAE	1-5/8-12	2-1/2-12	U20/U40
SAE	1-7/8-12	1-7/8-12	U24/U24
Combination NPT & SAE	1-5/8-12	2	U20/N32

⑦ Valve

No bypass **0**
1 bar / 15 PSI **B1.0**
1,7 bar / 24.6 PSI **B1.7**

⑧ Length

Bowl Length 1 (1 element) **S1**
Bowl Length 2 (2 elements) **S2**
Note: RTF-47 size available in S1 bowl length only.

⑨ Clogging Indicator

No clogging indicator **0**
Visual clogging indicator **V**
Electrical clogging indicator **E**
Note: See page 125 for more details on indicator ports and options.

⑩ Design Code

Only for information **X**

Filter Elements ■ Type RTE

RTE - **48** - **D** - **10** - **B** / **X**

① ② ③ ④ ⑤ ⑥

① Type

Filter Element Series **RTE**

② Group

According to filter housing

③ Filter Material

Material	Max. Δp^* collapse	Micron ratings available	Code
Inorg. glass fibre	10 bar / 145 PSI	3, 5, 10, 25	G
Filter paper	10 bar / 145 PSI	10, 25	D

*Note: Collapse/burst resistance as per ISO 2941
Other materials on request

④ Micron Rating

3 μ m	03
5 μ m	05
10 μ m	10
25 μ m	25

Note: Other micron ratings on request

⑤ Sealing Material

NBR (Buna®) **B**
Note: Other sealing materials on request

⑥ Design Code

Only for information **X**

Return-Line Filters ■ Type RTF-50



D

Product Description

STAUFF RTF-50 Return-Line Filters are designed for tank top applications with a maximum pressure of 6,9 bar / 100 PSI. The filter bowl is designed to return the oil beneath the surface thus preventing entrainment of air. The RTF-58 elements interchange with the popular "K" series and RTF-59 elements interchange with the "RE-409" series elements.

Technical Data
Construction

- Tank Top flange mounting

Materials

- Filter head: Aluminium
- Filter bowl: Bowl length 1: Polyamide
Bowl length 2: Steel
- Sealings: NBR (Buna-N®)
Other sealing materials on request

Port Connections

- BSP
- NPT
- SAE O-ring thread

Flow Rating

- Up to 379 l/min / 100 US GPM

Operating Pressure

- Max. 6,9 bar / 100 PSI

Temperature Range

- -25 °C ... +95 °C / -13 °F ... +203 °F

Filter Elements

- Specifications see page 118

Media Compatibility

- Mineral oils, other fluids on request

Options and Accessories
Valve

- Bypass valve: Opening pressures 1 bar / 14.5 PSI \pm 10 % or 1,7 bar / 25 PSI \pm 10 %
Other settings available on request

Clogging Indicators

- For clogging indicator types please see page 125

Return-Line Filters ▪ Type RTF-50

D

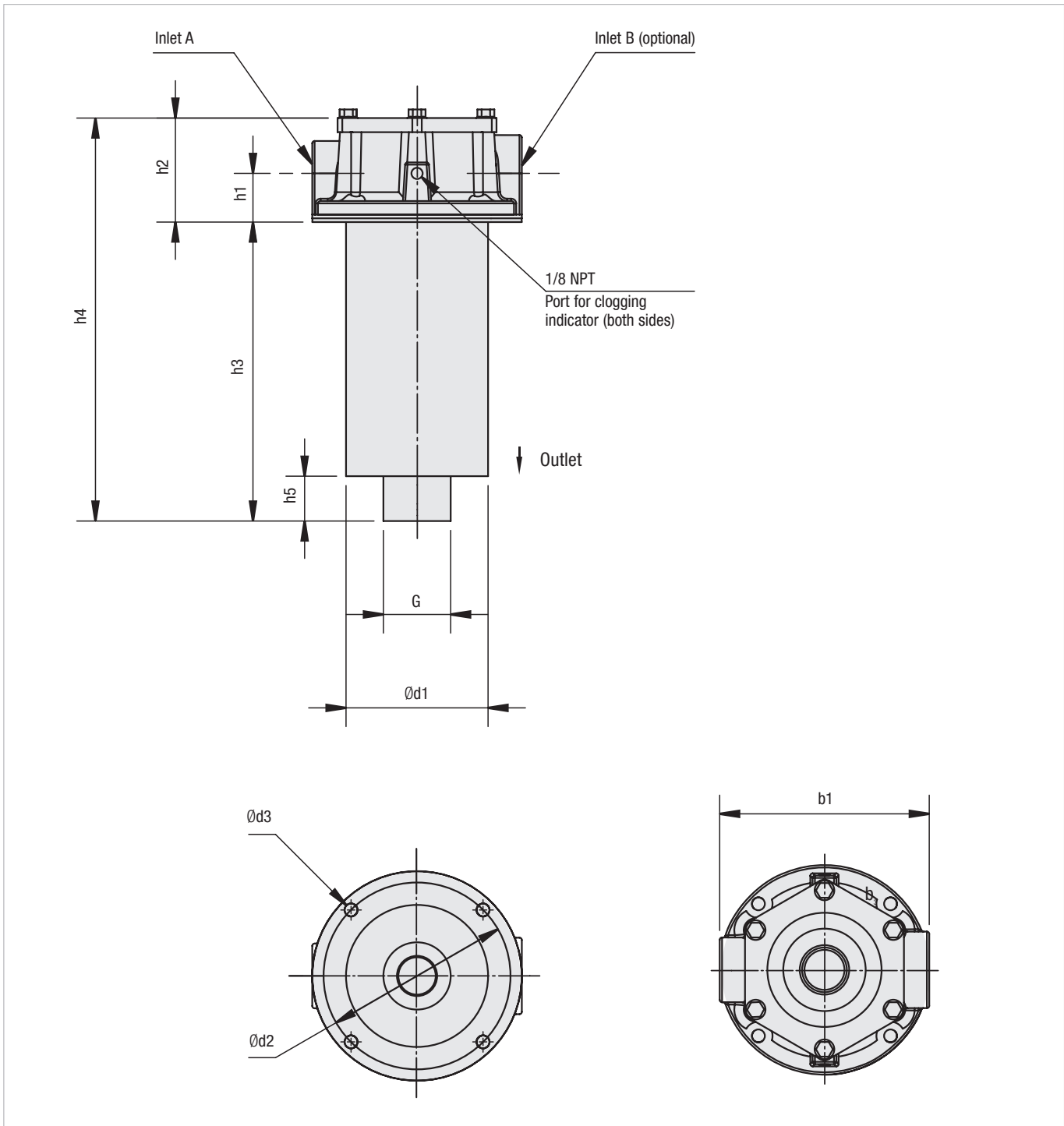

Return-Line Filters ▪ Type RTF Accessories

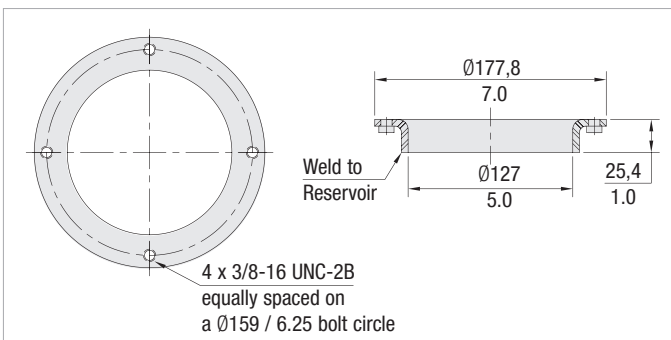

RTF-50 Series Weld Ring WR-40

The WR-40 weld ring is welded directly to the hydraulic reservoir, eliminating the need for drilling and tapping mounting holes in the reservoir.

Material: Carbon Steel

Dimensions in mm / in

Return-Line Filters ■ Type RTF-50

Thread Connection Combinations	Filter Size RTF			
	5...S1		5...S2	
	Inlet A	Inlet B	Inlet A	Inlet B
NPT (N)	1-1/4	None	1-1/4	None
NPT (NM)	1-1/4	1-1/2	1-1/4	1-1/2
NPT (M)	None	1-1/2	None	1-1/2
Combination SAE & NPT (SM)	1-5/8-12	1-1/2	1-5/8-12	1-1/2
SAE (S)	1-5/8-12	None	1-5/8-12	None
SAE (T)	None	1-7/8-12	None	1-7/8-12
SAE (ST)	1-5/8-12	1-7/8-12	1-5/8-12	1-7/8-12
Combination NPT & SAE (NT)	1-1/4	1-7/8-12	1-1/4	1-7/8-12

Dimensions (mm/in)	Filter Size RTF	
	5...S1	5...S2
h1	49,3	42,3
	1.94	1.67
h2	95,5	88,5
	3.78	3.48
h3	241,3	485,9
	9.50	19.13
h4	336,8	574,9
	13.26	22.61
h5	29,5	38,1
	1.16	1.50
b1	177,8	177,8
	7.00	7.00
d1	124,8	126
	4.91	4.96
d2	158,7	158,7
	6.25	6.25
d3	11,2	11,2
	.44	.44
G	1-1/2 NPT	1-1/2 NPT

D

Return-Line Filter Housings / Complete Filters ■ Type RTF-50

RTF - **58** - **D** - **10** - **B** - **N20/0** - **B1.7** - **S2** - **V** / **X**

① ② ③ ④ ⑤ ⑥ ⑦ ⑧ ⑨ ⑩

① Type

Return-Line Filter **RTF**

② Group

Flow	Size
Group size 58	58
Group size 59	59

Note: Exact flow will depend on the selected filter element.
For technical data please see pages 123 / 124.

③ Filter Material

Material	Max. Δp*collapse	Micron ratings available	Code
Without filter element	-	-	0
Inorg. glass fibre	10 bar / 145 PSI	3, 5, 10, 25	G
Filter paper	5 bar / 72.5 PSI	10, 25	D

*Note: Collapse/burst resistance as per ISO 2941
Other materials on request

④ Micron Rating

3 μm	03
5 μm	05
10 μm	10
25 μm	25

Note: Other micron ratings on request

⑤ Sealing Material

NBR (Buna®) **B**
Note: Other sealing materials on request

⑥ Connection Style

Connection Style	Group		Code
	Port A	Port B	
NPT	1-1/4	None	N20/0
NPT	1-1/4	1-1/2	N20/N24
NPT	None	1-1/2	0/N24
Combination SAE & NPT	1-5/8-12	1-1/2	U20/N24
SAE	1-5/8-12	None	U20/0
SAE	None	1-7/8-12	0/U24
SAE	1-5/8-12	1-7/8-12	U20/U24
Combination NPT & SAE	1-1/4	1-7/8-12	N20/U24

⑦ Valve

No bypass	0
1 bar / 15 PSI	B1.0
1,7 bar / 24.6 PSI	B1.7

⑧ Length

Bowl Length 1 (1 element)	S1
Bowl Length 2 (2 elements)	S2

⑨ Clogging Indicator

No clogging indicator	0
Visual clogging indicator	V
Electrical clogging indicator	E

Note: See page 125 for more details on indicator ports and types.

⑩ Design Code

Only for information **X**

Filter Elements ■ Type RTE

RTE - **58** - **D** - **10** - **B** - **X**

① ② ③ ④ ⑤ ⑥

① Type

Filter Element Series **RTE**

② Group

According to filter housing

③ Filter Material

Material	Max. Δp*collapse	Micron ratings available	Code
Inorg. glass fibre	10 bar / 145 PSI	3, 5, 10, 25	G
Filter paper	5 bar / 72.5 PSI	10, 25	D

*Note: Collapse/burst resistance as per ISO 2941
Other materials on request

④ Micron Rating

3 μm	03
5 μm	05
10 μm	10
25 μm	25

Note: Other micron ratings on request

⑤ Sealing Material

NBR (Buna®) **B**
Note: Other sealing materials on request

⑥ Design Code

Only for information **X**

Return-Line Filters ■ Type RTF-N



D

Product Description

STAUFF RTF-N Return-Line Insert Filters allow for a choice of installation configurations which permits custom reservoir design with an in tank filtering system. The filters are installed semi-immersed or totally immersed into a reservoir. The filtration flow is from inside to the outside of the element which ensures that all the contaminant is collected inside the element itself avoiding contact with the reservoir fluid during element change. The combination of magnetic pre-filtration and high filtration efficiency results in a cost effective and versatile filtration system.

Technical Data
Construction

- Insert filter

Materials

- Flange plate: Aluminium
- Magnet rod: Steel
- Bypass: Steel
- Diffuser: Steel
- Sealings: NBR (Buna-N®)
FKM (Viton®)
Other sealing materials on request

Flow Rating

- Up to 500 l/min / 132 US GPM

Operating Pressure

- Max. 10 bar / 145 PSI

Temperature Range

- -29 °C ...+107 °C / -20 °F ... +225 °F

Filter Elements

- Specifications see page 122

Media Compatibility

- Mineral oils, other fluids on request

Options and Accessories
Valve

- Bypass valve: Opening pressure 1,5 bar / 22 PSI
(integrated in the filter element) Other settings available on request

Return-Line Filters ■ Type RTF-N

D

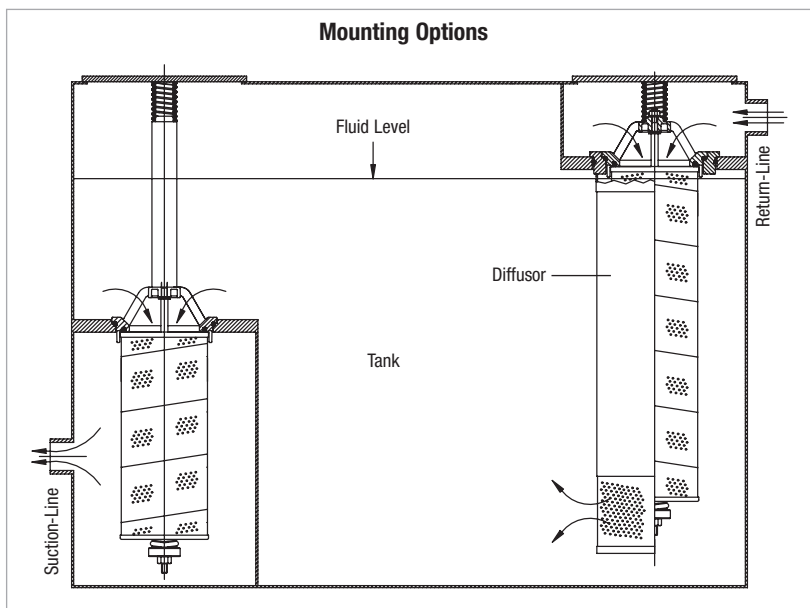
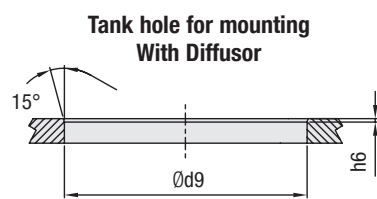
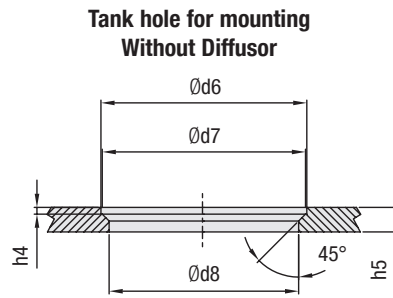
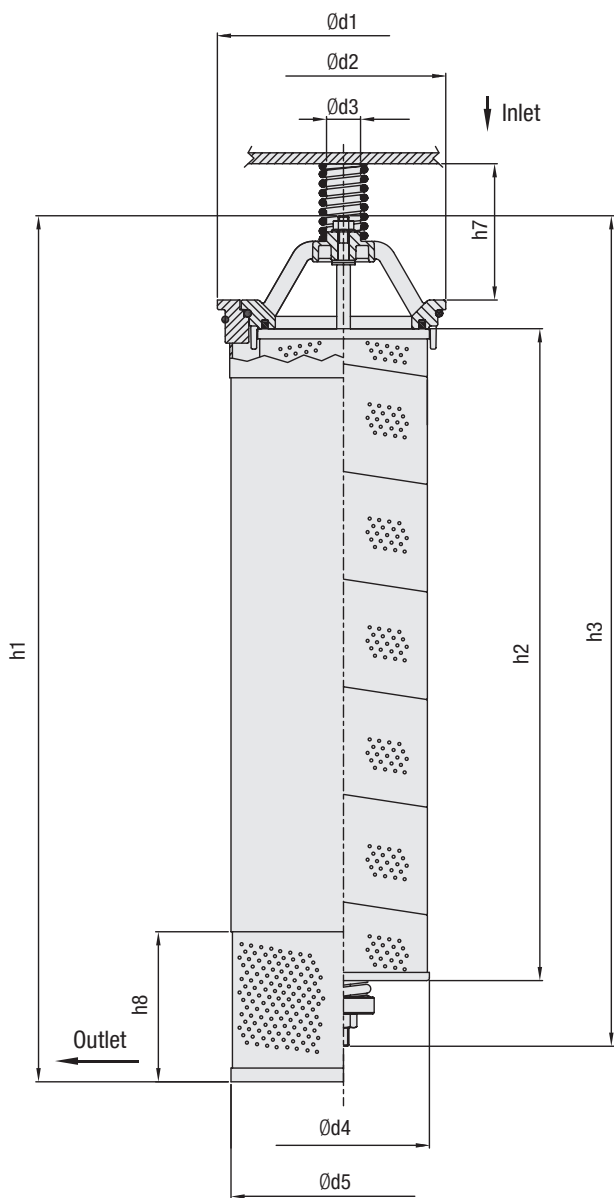

Return-Line Filters ▪ Type RTF-N

Dimensions (mm/in)	Filter Size RTF-N	
	390	500
h1	445	635
	17.52	25.00
h2	290	478
	11.42	18.82
h3	421	609
	16.57	23.98
h4	5	5
	.20	.20
h5	18	18
	.71	.71
h6	2,5	2,5
	.10	.10
h7	100	100
	3.94	3.94
h8	110	110
	4.33	4.33
d1	185	185
	7.28	7.28
d2	150	150
	5.91	5.91
d3	25	25
	.98	.98
d4	126	126
	4.95	4.95
d5	165	165
	6.50	6.50
d6	151	151
	5.94	5.94
d7	149	149
	5.87	5.87
d8	139	139
	5.47	5.47
d9	178	178
	7.01	7.01

D

Return-Line Filter Housings / Complete Filters ■ Type RTF-N

RTF-N - 500 - E - 10 - B - B1.5 - D / X

① ② ③ ④ ⑤ ⑥ ⑦ ⑧

① Type

Return-Line Insert Filter **RTF-N**

② Group

Flow	Size
390 l/min / 103 US GPM	390
500 l/min / 132 US GPM	500

Note: Exact flow will depend on the selected filter element.
For technical data please see pages 13 / 124.

③ Filter Material

Material	Max. Δp^* collapse	Micron ratings available	Code
Without filter element	-	-	0
Inorg. glass fibre	10 bar / 145 PSI	3, 5, 10, 20	E
Filter paper	10 bar / 145 PSI	10	L

*Note: Collapse/burst resistance as per ISO 2941
Other materials on request

④ Micron Rating

3 μm	03
5 μm	05
10 μm	10
20 μm	20

Note: Other micron ratings on request

⑤ Sealing Material

NBR (Buna®) **B**
FKM (Viton®) **V**

Note: Other sealing materials on request

⑥ Bypass Setting

1,5 bar / 22 PSI **B1.5**

⑦ Options

Without diffusor **0**
With diffusor **D**

⑧ Design Code

Only for information **X**

Filter Elements ■ Type RA

RA - 500 - E - 10 - B / X

① ② ③ ④ ⑤ ⑥

① Type

Element for Insert Filter **RA**

② Group

According to filter housing

③ Filter Material

Material	Max. Δp^* collapse	Micron ratings available	Code
Inorg. glass fibre	10 bar / 145 PSI	3, 5, 10, 20	E
Filter paper	10 bar / 145 PSI	10	L

*Note: Collapse/burst resistance as per ISO 2941
Other materials on request

④ Micron Rating

3 μm	03
5 μm	05
10 μm	10
20 μm	20

Note: Other micron ratings on request

⑤ Sealing Material

NBR (Buna®) **B**
FKM (Viton®) **V**

Note: Other sealing materials on request

⑥ Design Code

Only for information **X**

Return-Line Filters ■ Type RTF Flow Characteristics

The following characteristics are valid for mineral oils with a density of 0,85 kg/dm³ and the kinematic viscosity of 30 mm²/s (30cSt). The characteristics have been determined in accordance to ISO 3968. Multipass filter ratings have been obtained in accordance to ISO 16889. The housing pressure drop is directly proportional to the oil density. Contact STAUFF for details.

**Filter Housing
RTF-20**

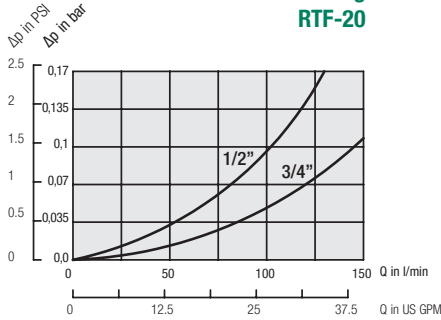

**Filter Breather
RTEA-20**

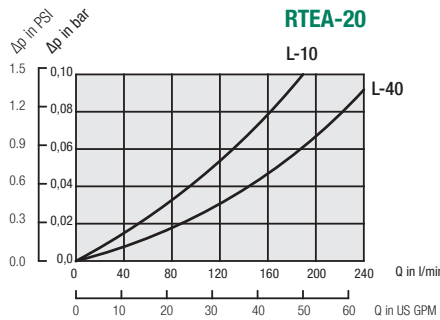

**Filter Elements
RTE-20**

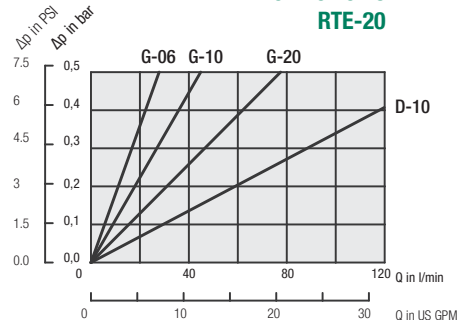

**Filter Housing
RTF-10/15/25**

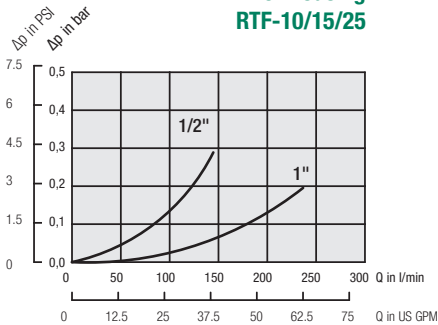

**Filter Elements
RTE-10**

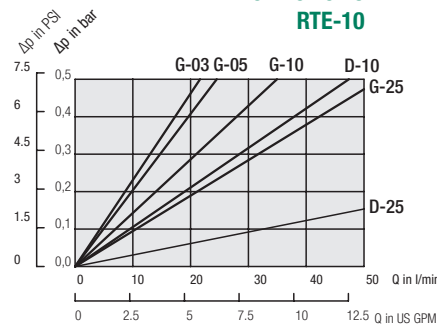

**Filter Elements
RTE-15**

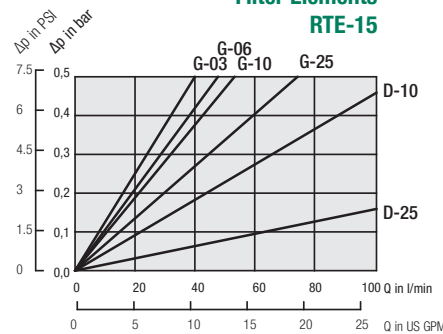

**Filter Elements
RTE-25**

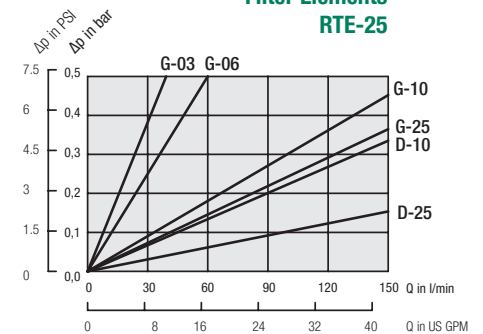

**Filter Housing
RTF-40**

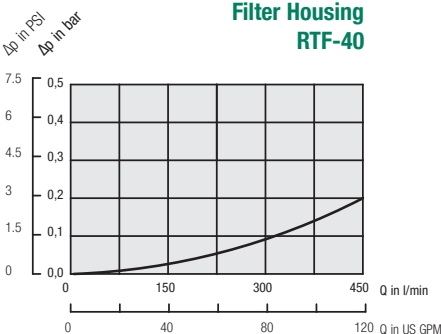

**Filter Elements
RTE-47-D**

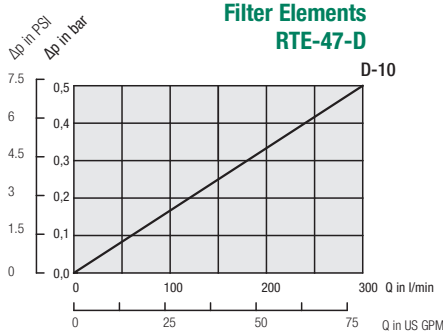

**Filter Elements
RTE-47-G**

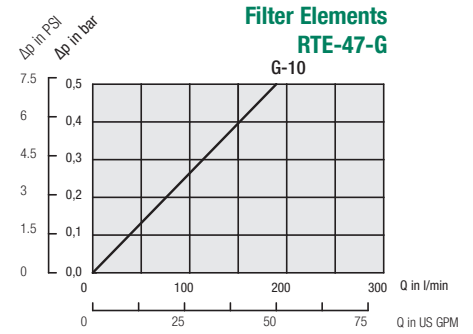

**Filter Elements
RTE-48-D**

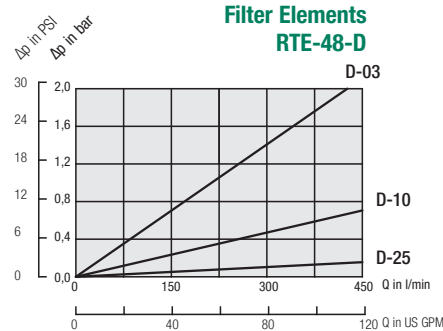

**Filter Elements
RTE-48-G**

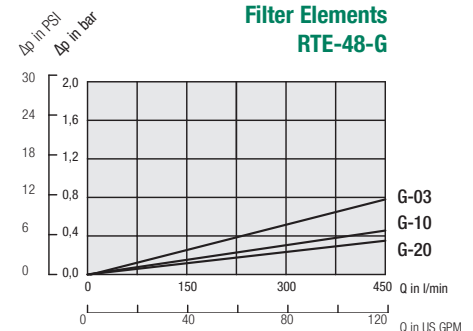

D

Return-Line Filters ■ Type RTF Flow Characteristics

The following characteristics are valid for mineral oils with a density of 0,85 kg/dm³ and the kinematic viscosity of 30 mm²/s (30cSt). The characteristics have been determined in accordance to ISO 3968. Multipass filter ratings have been obtained in accordance to ISO 16889. The housing pressure drop is directly proportional to the oil density. Contact STAUFF for details.

D

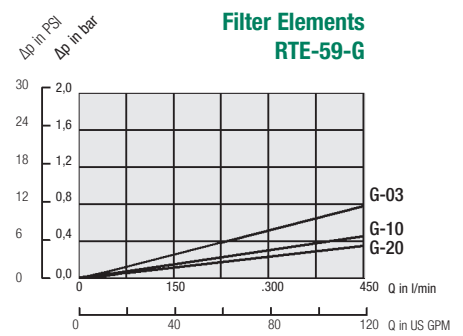
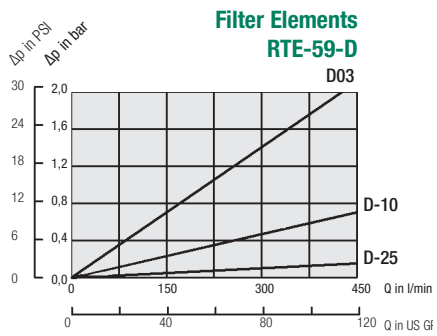
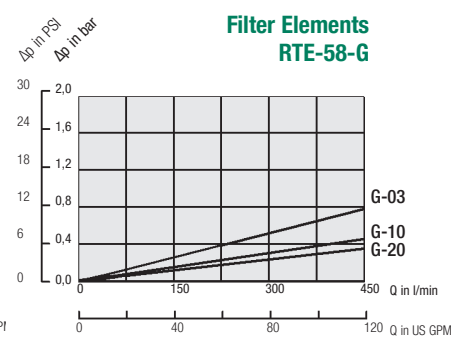
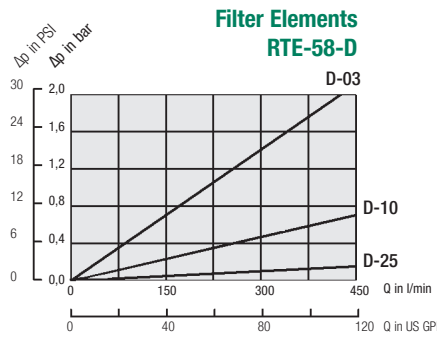
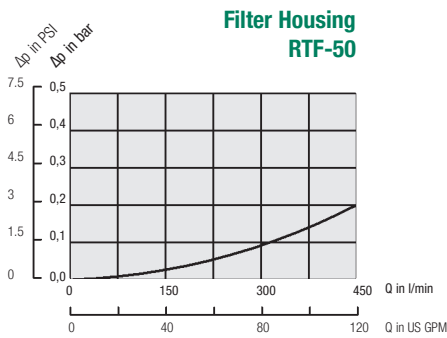
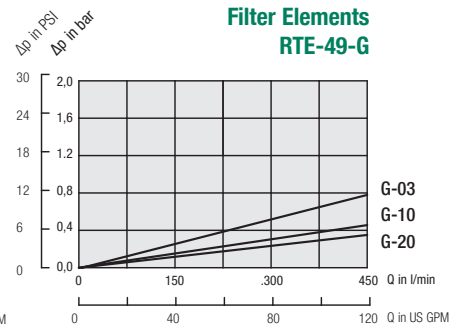
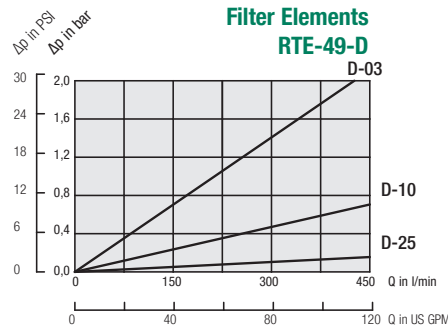

Note: Element pressure drop curves are for "S1" single elements. For "S2" double elements use 50% of the "S1" Value.

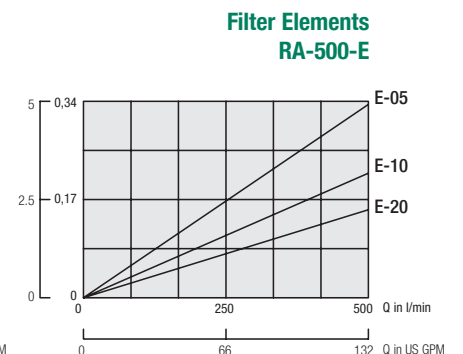
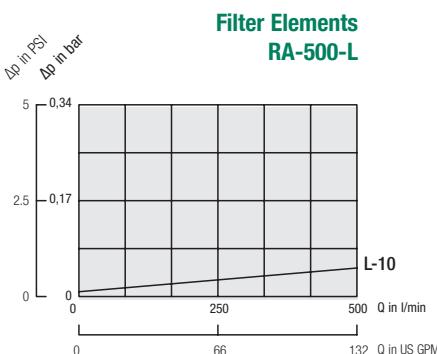
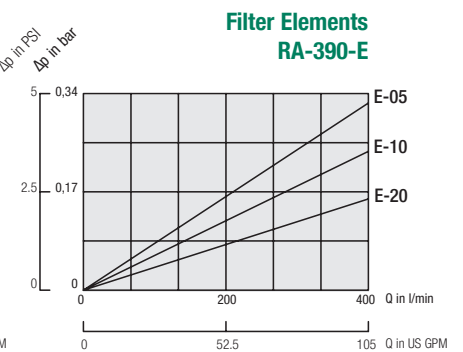
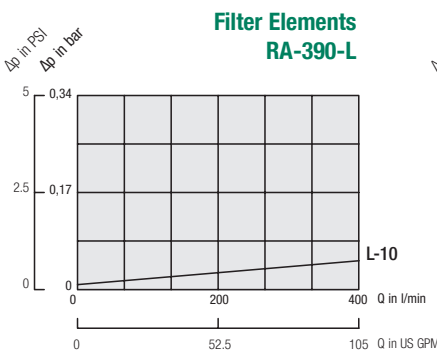
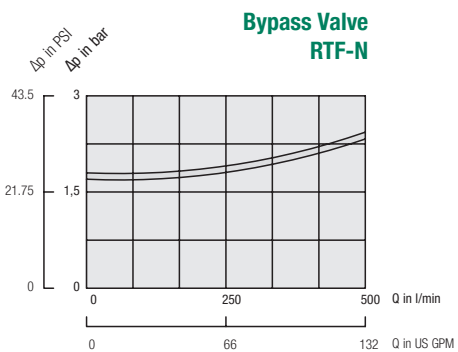

RTF Filter Indicators

Visual Indicators

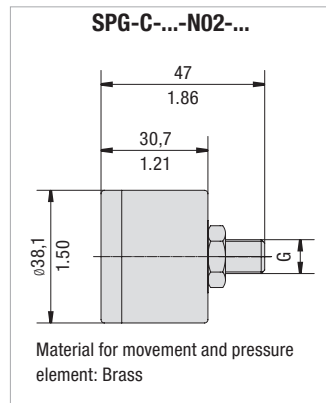
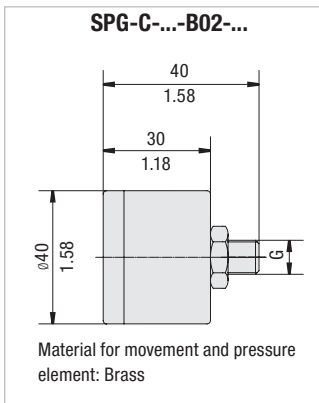

SPG-C-...-B02-..



SPG-C-...-N02-...

Visual Pressure Clogging Indicators						Order Code	
Thread Connection G	Unit of scale	Range of scale	Coloured Segments				
			Green	Yellow	Red		
BSP	1/8	bar	0 ... 2,5	0 ... 1,2	1,2 ... 1,5	1,5 ... 2,5	SPG-C-040-00002.5-02-P-B02-402923
	1/8	bar	0 ... 4	0 ... 2,5	2,5 ... 3	3 ... 4	SPG-C-040-00004-02-P-B02-402922
	1/8	bar	0 ... 12	without coloured segments			SPG-C-040-00012-02-P-B02
NPT	1/8	PSI	0 ... 100	0 ... 13	13 ... 15	15 ... 100	SPG-C-040-00100-03-P-N02-402927
	1/8	PSI	0 ... 100	0 ... 21	21 ... 25	25 ... 100	SPG-C-040-00100-03-P-N02-402928

Electrical Clogging Switch

Order Code

Limit-Switch - G42NO - S - B02 - B1.3

①

②

③

④

⑤

① Type

Limit-Switch

② Connector Type

Electrical Clogging Switch 10 V ... 42 V, NO	G42NO
Electrical Clogging Switch 10 V ... 42 V, NC	G42NC
Electrical Clogging Switch 10 V ... 250 V, two-way contact (only for Plug Type W)	G230

③ Plug Type

M12 Five-Pin Connector according to IEC 61076-2-101	M12
AMP-Junior-Timer Plug	A
DEUTSCH Plug DT04-2P	D
Rubber boot	S
90 degree Polyamide cap (only for Connector Type G230)	W

④ Thread Type

1/8 BSP	B02
1/8 NPT	N02

⑤ Pressure Setting

1,3 bar / 18.8 PSI	B1.3
--------------------	-------------

Note: Technical Data for Limit-Switch types please see Page 73.

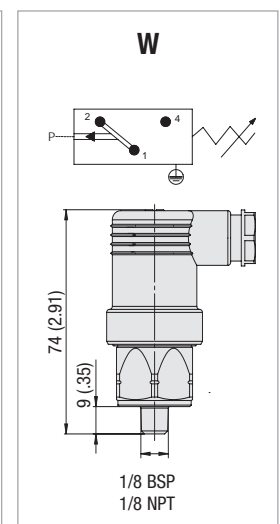
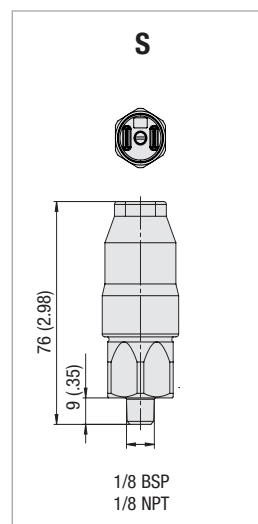
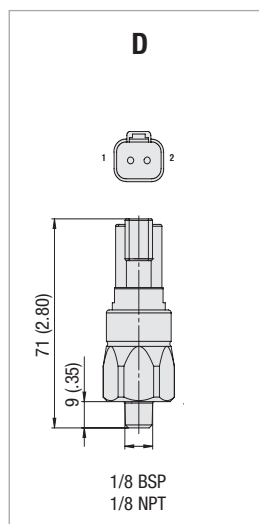
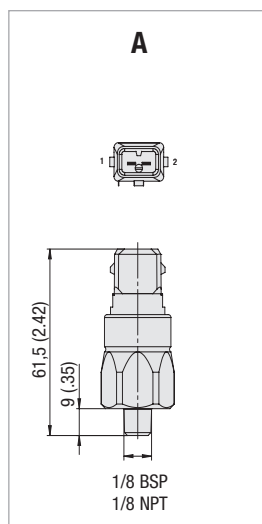
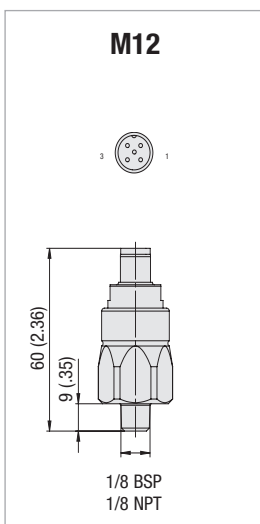

Note: The customer / user carries the responsibility for the electrical connection.

Dimensional drawings: All dimensions in mm/in.

Overview In-Line Filters 128

SRFL-S / SRFL-D / SRFL-SW



In-Line Filters	SRFL-S / SRFL-D	129 - 142
Max. 14 bar / 200 PSI		
Max. 7000 l/min / 1850 US GPM		

Technical Data / Dimensions 130 - 139

Order Code - In-Line Filter 140

Order Code - Filter Elements 140

Differential Pressure Switch with Visual Gauge Indicator 141

Flow Characteristics 142



In-Line Filters	SRFL-SW	143 - 147
Max. 16 bar / 232 PSI		
Max. 13330 l/min / 3521 US GPM		

Technical Data / Dimensions 144 - 145

Order Code - In-Line Filter 146

Order Code - Filter Elements 146

Differential Pressure Switch with Visual Gauge Indicator 147

E

Description

STAUFF In-Line Simplex Filters SRFL-S and Duplex Filters SRFL-D are designed for in-line hydraulic applications. With its compact construction and the easy maintain assembly the SRFL-S and SRFL-D Filters are suitable for flow rates up to 7000 l/min / 1850 US GPM.

The two housings of the Duplex Filter SRFL-D are connected with a special gate valve that is operated with a level or hand wheel. Therefore the filter may be serviced without shutting down the hydraulic system.

The STAUFF In-Line Filter SRFL-SW is designed for installation in water circulations. This filter can be used for cleaning of e.g. industrial water of descaling systems. The filter elements are designed as basket strainers, which keep the dirt during the element change.

Media Compatibility

- Mineral oils, lubrication oils and water, others on request

Options and Accessories

Valves (except REL Filter Elements)

- Bypass valve (integrated in the filter element)

Clogging Indicators

- On request with visual and electrical differential pressure indicator
- The SRFL-SW is also available with an visual-electrical differential pressure indicator



Type SRFL-S

- Version: Simplex
- Operating pressure: max. 14 bar / 200 PSI
- Nominal flow rate: max. 7000 l/min / 1850 US GPM
- Materials: Filter housing: Carbon Steel, Stainless Steel (on request)
- Connections: ANSI, DIN or SAE flange (ISO 6162-1/2)



Type SRFL-SW

- Version: Simplex, suitable for water Duplex on request
- Operating pressure: max. 16 bar / 232 PSI
- Nominal flow rate: max. 13330 l/min / 3521 US GPM
- Materials: Filter housing: Carbon Steel, Stainless Steel (on request)
- Connections: ANSI or DIN flange



Type SRFL-D

- Version: Duplex
- With switch control for maintenance of the system without stoppage
- Operating pressure: max. 14 bar / 200 PSI
- Nominal flow rate: max. 7000 l/min / 1850 US GPM
- Materials: Filter housing: Carbon Steel, Stainless Steel (on request)
- Connections: ANSI, DIN or SAE flange (ISO 6162-1/2)

In-Line Filters ■ Type SRFL-S / D

Product Description

STAUFF In-Line Simplex Filters SRFL-S and Duplex Filters SRFL-D are designed for in-line hydraulic applications. With its compact construction and the easy maintain assembly the SRFL-S and SRFL-D Filters are suitable for flow rates up to 7000 l/min / 1850 US GPM. The two housings of the Duplex Filter SRFL-D are connected with a special gate valve that is operated with a level or hand wheel. Therefore the filter may be serviced without shutting down the hydraulic system. A high efficiency of contaminant removal is assured by using STAUFF RE series Replace-ment Filter Elements. The high dirt-hold capacity of STAUFF Elements ensure a long service life and, as a result, reduced maintenance costs.

Technical Data
Construction

- In-line assembly, base mounted

Materials

- Filter housing: Carbon Steel
Stainless Steel (on request)
- Sealings: NBR (Buna-N®)
FKM (Viton®)
Other sealing materials on request

Port Connections

- DIN flange
- ANSI flange
- SAE flange

Operating Pressure

- Max. 14 bar / 200 PSI

Flow Rating

- Up to 7000 l/min / 1850 US GPM

Temperature Range

- -20 °C ... +100 °C / -44 °F ... +212 °F
(Short term up to +110 °C / +230 °F)

Filter Elements

- Specifications see page 140

Media Compatibility

- Mineral oils, lubrication oils, other fluids on request

Options and Accessories
Valve

- Bypass valve: Opening pressure 3 bar ± 0,3 bar / 43.5 PSI ± 4.35 PSI
(integrated in the filter element) Other settings available on request

Clogging Indicators

- Differential pressure switch incl. visual indicator, setting 1,6 bar / 23 PSI
Other clogging indicators available on request

Filter Size	Flow l/min/ US GPM	Flange			Filter Element quantity		Arrangement of filter elements	Page
		DIN 2501	ANSI B 16.5	SAE 3000 PSI	SRFL-S	SRFL-D		
SRFL-S/D-160	900/240	DN 40	1-1/2	1-1/2	1x RE-160	2x RE-160		130 / 134
SRFL-S/D-200	900/240	DN 50	2	2	1x RE-200	2x RE-200		
SRFL-S/D-300	1400/370	DN 65	2-1/2	2-1/2	1x RE-300	2x RE-300		
SRFL-S/D-600	1400/370	DN 80	3	3	1x RE-600	2x RE-600		132 / 136
SRFL-S/D-1200	4000/1050	DN 100	4	4	2x RE-600	4x RE-600		
SRFL-S/D-1800	4000/1050	DN 125	5	5	3x RE-600	6x RE-600		132 / 138
SRFL-S/D-2400	6000/1580	DN 150	6	6	4x RE-600	8x RE-600		
SRFL-S/D-3600	7000/1850	DN 200	8	8	6x RE-600	12x RE-600		132 / 138

E

In-Line Filters ■ Type SRFL-S-160 / 200 / 300 / 600

Detail arrangement of filter elements



SRFL-S-160 / 200 / 300 / 600

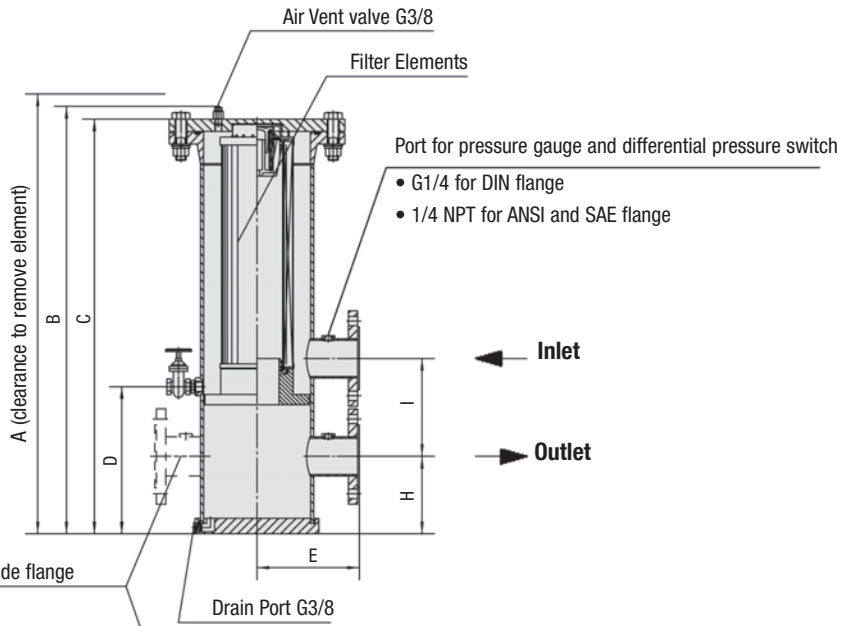
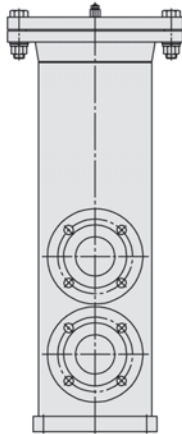

Option: Opposite side flange
see detail

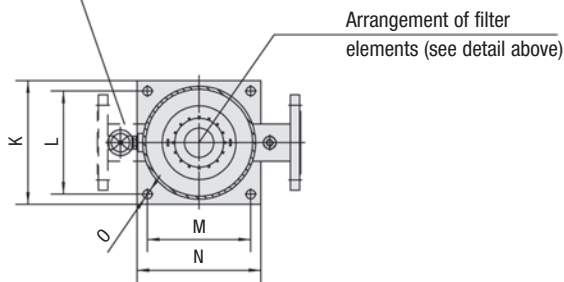
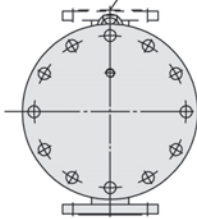

Option: Connection location

S (same side)

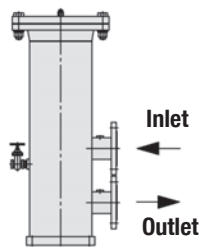

O (opposite side)

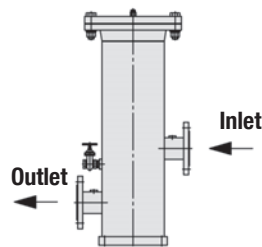

E

In-Line Filters ■ Type SRFL-S-160 / 200 / 300 / 600

Flange Connection	Filter Size SRFL-S			
	160	200	300	600
DIN	DN 40	DN 50	DN 65	DN 80
ANSI	1-1/2	2	2-1/2	3
SAE	1-1/2	2	2-1/2	3

Dimensions (mm/in)	Filter Size SRFL-S			
	160	200	300	600
A	885,8	1045,8	1248,7	2126,7
	34.87	41.17	49.16	83.73
B	607,6	688,7	828,6	1267,6
	23.92	27.12	32.63	49.91
C	584	664	803,9	1242,9
	22.99	26.14	31.65	48.93
D	214	214	285	285
	8.43	8.43	11.22	11.22
E	148	148	198	198
	5.83	5.83	7.80	7.80
H	130	140	150	160
	5.12	5.51	5.91	6.30
I	155	190	190	220
	6.10	7.48	7.48	8.66
K	150	150	240	240
	5.91	5.91	9.45	9.45
L	125	125	200	200
	4.92	4.92	7.87	7.87
M	125	125	200	200
	4.92	4.92	7.87	7.87
N	150	150	240	240
	5.91	5.91	9.45	9.45
O	11	11	18	18
	.43	.43	.71	.71
Total Oil Capacity (l/gal)	6,0	7,1	22,2	37,1
	1.59	1.86	5.87	9.80
Weight (kg/lbs)	14,5	15,9	29	34,5
	32	35	64	76
Filter Elements	Designation	RE-160 ...	RE-200 ...	RE-300 ...
	Quantity	1 x 1	1 x 1	1 x 1

E

In-Line Filters ■ Type SRFL-S-1200 / 1800 / 2400 / 3600

Detail arrangement of filter elements



E

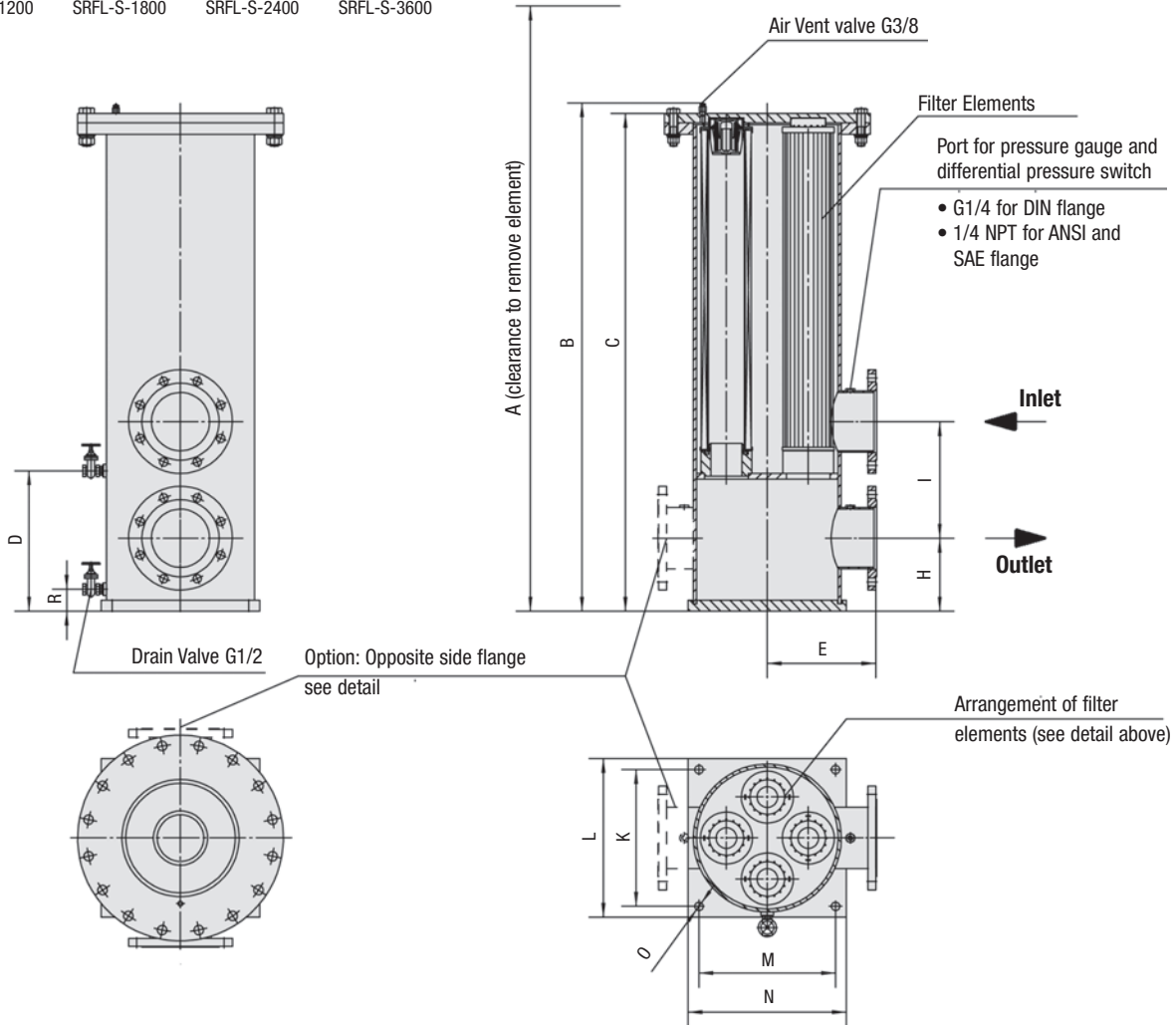

Option: Connection location

S (same side)

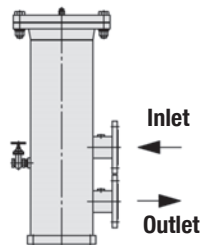

O (opposite side)

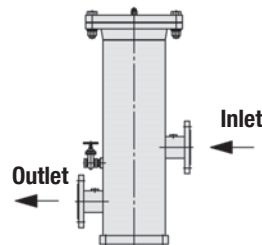

In-Line Filters ■ Type SRFL-S-1200 / 1800 / 2400 / 3600

Flange Connection	Filter Size SRFL-S			
	1200	1800	2400	3600
DIN	DN 100	DN 125	DN 150	DN 200
ANSI	4	5	6	8
SAE	4	5	6	8

Dimensions (mm/in)	Filter Size SRFL-S			
	1200	1800	2400	3600
A	2176,7	2176,7	2249,1	2249,1
	85.70	85.70	88.55	88.55
B	1319,6	1323,6	1394,8	1392,8
	51.96	52.11	54.92	54.84
C	1294,6	1294,9	1366,1	1368,1
	50.98	50.98	53.78	53.86
D	275	275	325	325
	10.83	10.83	12.80	12.80
E	273	273	298	398
	10.75	10.75	11.73	15.67
H	190	190	200	252
	7.48	7.48	7.87	9.92
I	250	280	320	425
	9.84	11.02	12.6	16.73
K	385	385	435	540
	15.16	15.16	17.13	21.26
L	325	325	375	480
	12.80	12.80	14.76	18.90
M	325	325	375	480
	12.80	12.80	14.76	18.90
N	385	385	435	540
	15.16	15.16	17.13	21.26
O	23	23	23	23
	.91	.91	.91	.91
R	60	60	60	60
	2.36	2.36	2.36	2.36
Total Oil Capacity (l/gal)	103	103	149	232
	27.21	27.21	39.37	61.30
Weight (kg/lbs)	86,2	90,7	105,2	154,2
	190	200	232	340
Filter Elements	Designation	RE-600 ...	RE-600 ...	RE-600 ...
	Quantity	1 x 2	1 x 3	1 x 4

E

In-Line Filters ■ Type SRFL-D-160 / 200 / 300 / 600

Detail arrangement of filter elements



SRFL-D-160 / 200 / 300 / 600

Detail connecting ports

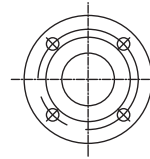

Flange 1-1/2, 2, 2-1/2

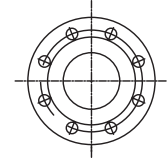

Flange 3

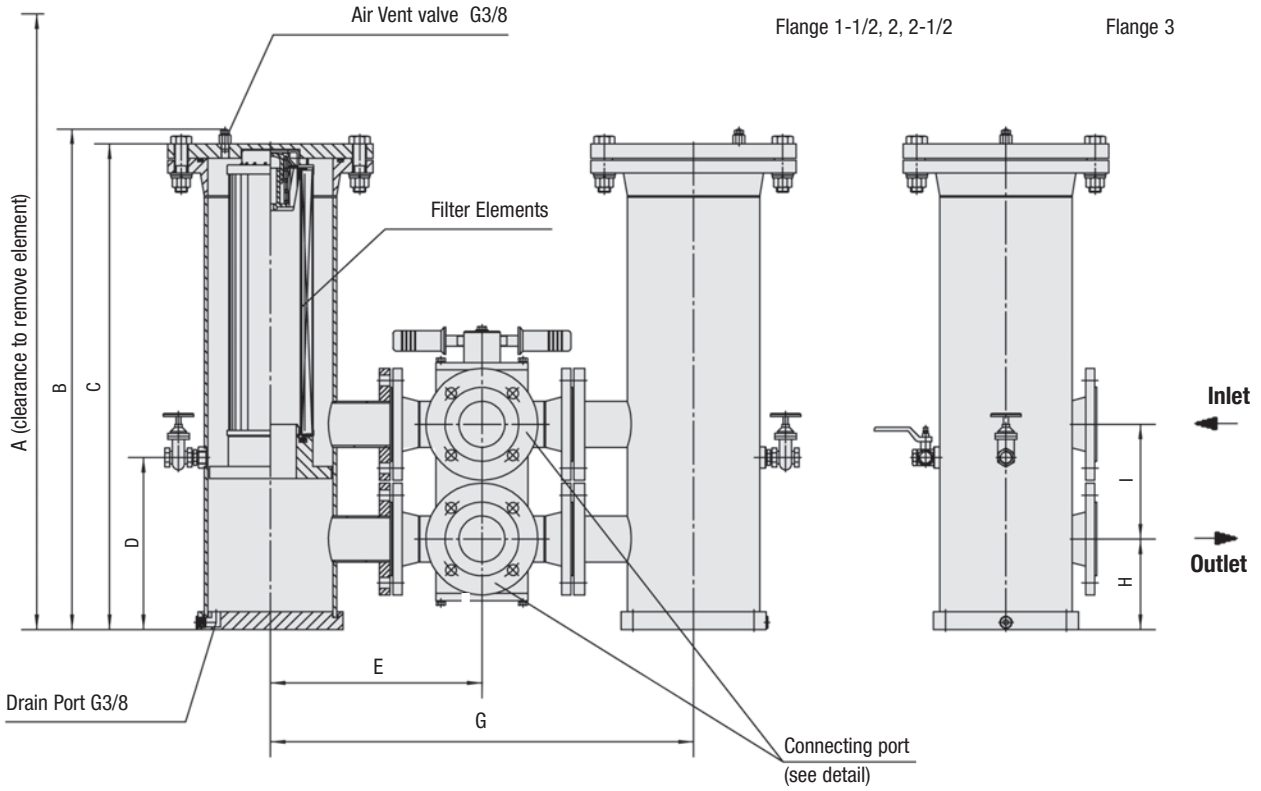

Arrangement of filter elements (see detail above)

Pressure tap
Balance line 1/2"

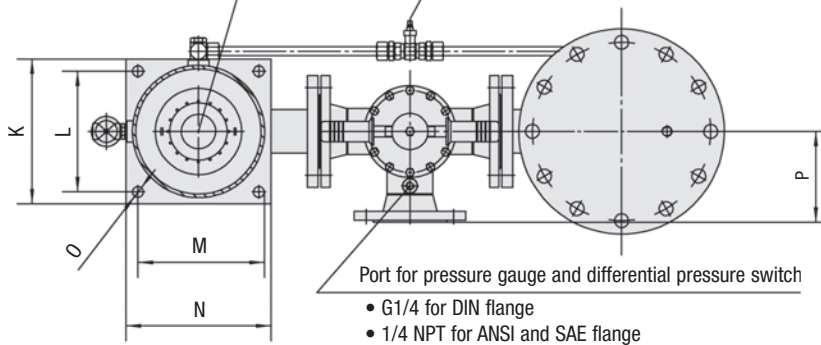

Port for pressure gauge and differential pressure switch

- G1/4 for DIN flange
- 1/4 NPT for ANSI and SAE flange

E

In-Line Filters ■ Type SRFL-D-160 / 200 / 300 / 600

Flange Connection	Filter Size SRFL-D			
	160	200	300	600
DIN	DN 40	DN 50	DN 65	DN 80
ANSI	1-1/2	2	2-1/2	3

Dimensions (mm/in)	Filter Size SRFL-D				
	160	200	300	600	
A	885,8	1045,8	1248,7	2126,7	
	34.87	41.17	49.16	83.73	
B	607,6	688,7	828,6	1267,6	
	23.92	27.12	32.63	49.91	
C	584	642	803,9	1242,9	
	22.99	25.28	31.65	48.93	
D	214	214	285	285	
	8.43	8.43	11.22	11.22	
E	260	300	350	375	
	10.24	11.81	13.78	14.76	
G	520	600	700	750	
	20.47	23.62	27.56	29.53	
H	130	140	150	160	
	5.12	5.51	5.91	6.30	
I	155	190	190	220	
	6.10	7.48	7.48	8.66	
K	150	150	240	240	
	5.91	5.91	9.45	9.45	
L	125	125	200	200	
	4.92	4.92	7.87	7.87	
M	125	125	200	200	
	4.92	4.92	7.87	7.87	
N	150	150	240	240	
	5.91	5.91	9.45	9.45	
O	11	11	18	18	
	.43	.43	.71	.71	
P	110	150	150	175	
	4.33	5.91	5.91	6.89	
Total Oil Capacity (l/gal)	6	7,1	22,2	37,1	
	1.59	1.86	5.87	9.80	
Weight (kg/lbs)	43	56,7	84	104	
	95	125	185	230	
Filter Elements	Designation	RE-160 ...	RE-200 ...	RE-300 ...	RE-600 ...
	Quantity	2 x 1	2 x 1	2 x 1	2 x 1

E

In-Line Filters ■ Type SRFL-D-1200 / 1800 / 2400

Detail arrangement of filter elements

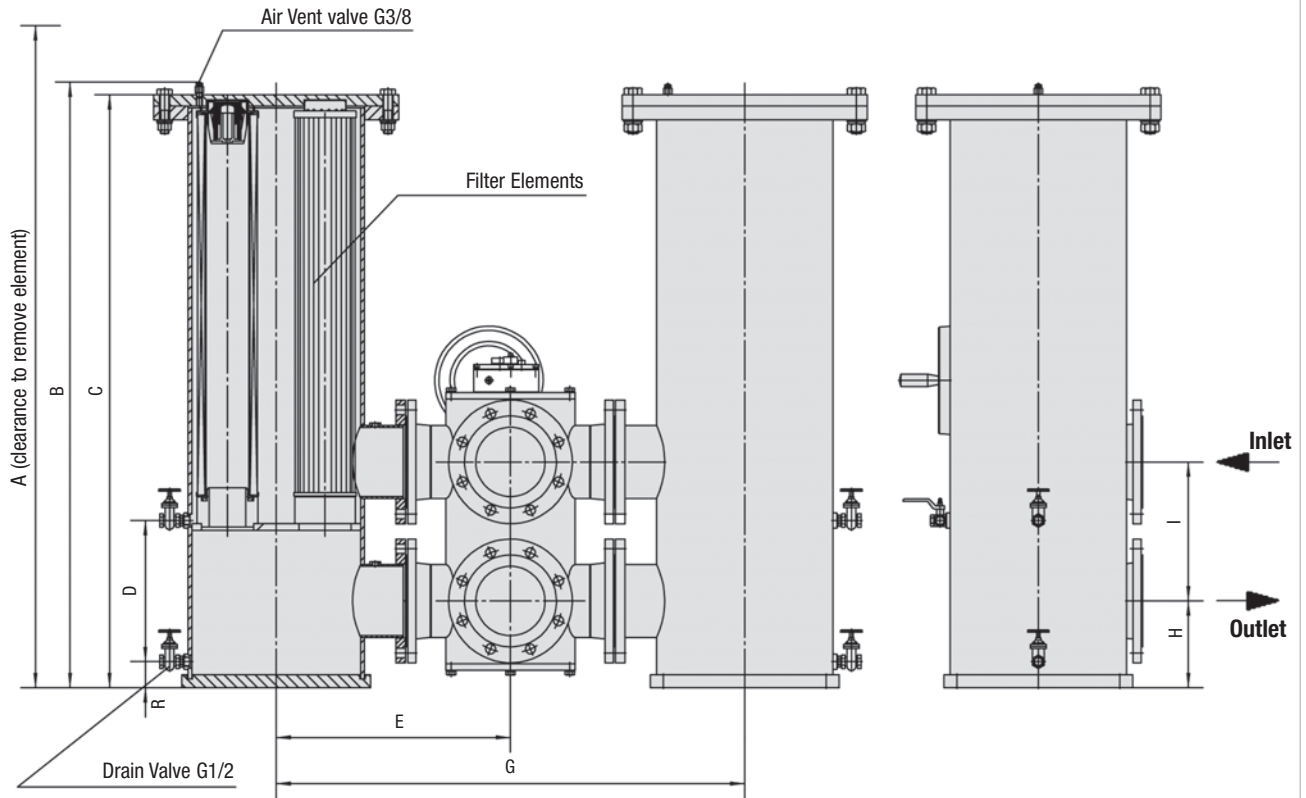

Arrangement of filter elements (see detail above)

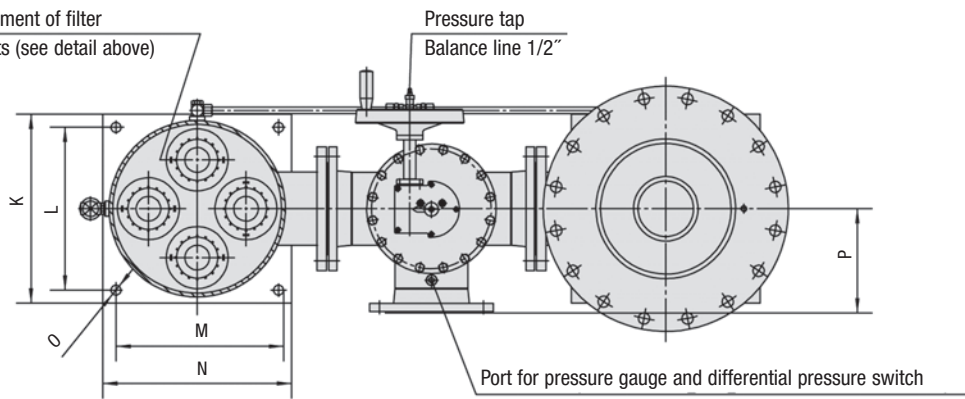

Port for pressure gauge and differential pressure switch

- G1/4 for DIN flange
- 1/4 NPT for ANSI and SAE flange

E

In-Line Filters ■ Type SRFL-D-1200 / 1800 / 2400

Flange Connection	Filter Size SRFL-D		
	1200	1800	2400
DIN	DN 100	DN 125	DN 150
ANSI	4	5	6

Dimensions (mm/in)	Filter Size SRFL-D		
	1200	1800	2400
A	2176,7	2176,7	2249,1
	85.70	85.70	88.55
B	1319,6	1323,6	1394,8
	51.96	52.11	54.92
C	1294,9	1294,9	1366,1
	50.98	50.98	53.78
D	275	275	325
	10.83	10.83	12.80
E	475	500	540
	18.70	19.69	21.26
G	950	1000	1080
	37.40	39.37	42.52
H	190	190	200
	7.48	7.48	7.87
I	250	280	320
	9.84	11.02	12.60
K	385	385	435
	15.16	15.16	17.13
L	325	325	375
	12.80	12.80	14.76
M	325	325	375
	12.80	12.80	14.76
N	385	385	435
	15.16	15.16	17.13
O	23	23	23
	.91	.91	.91
P	200	225	240
	7.87	8.86	9.45
R	60	60	60
	2.36	2.36	2.36
Total Oil Capacity (l/gal)	103	103	149
	27.20	27.20	39.30
Weight (kg/lbs)	215	233	263
	475	515	580
Filter Elements	Designation	RE-600 ...	RE-600 ...
	Quantity	2 x 2	2 x 3
			RE-600 ...
			2 x 4

E

In-Line Filters ■ Type SRFL-D-3600

Detail arrangement of filter elements



SRFL-D-3600

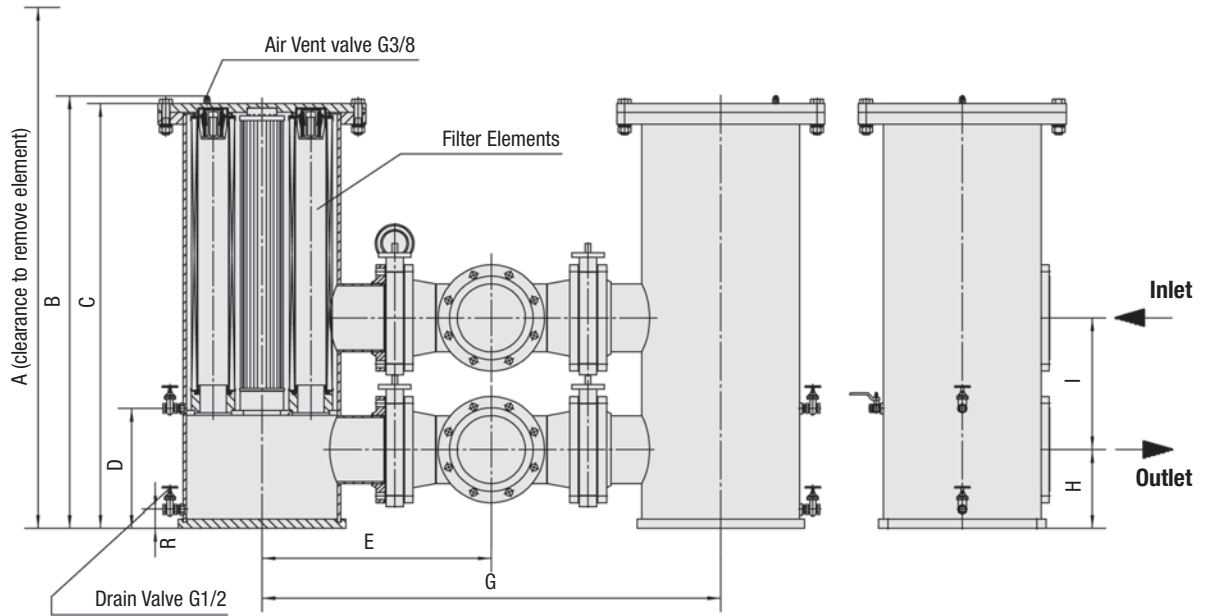

Arrangement of filter elements (see detail above)

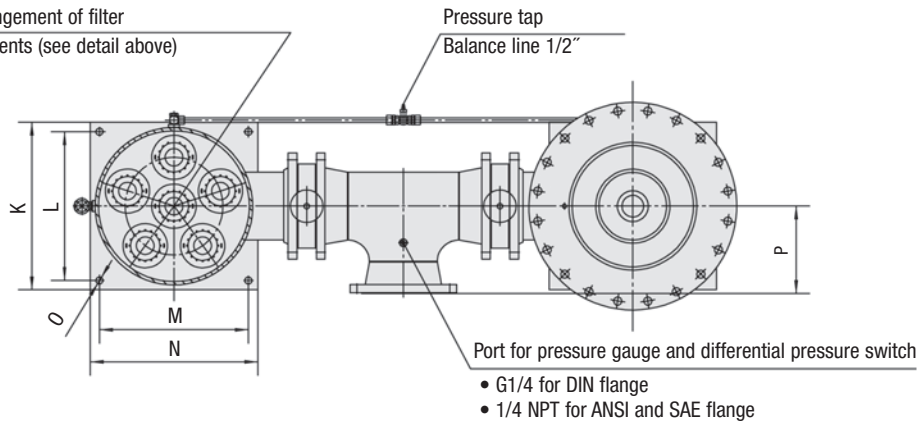

E

In-Line Filters ▪ Type SRFL-D-3600

Flange Connection	Filter Size SRFL-D
	3600
DIN	DN 200
ANSI	8

Dimensions (mm/in)	Filter Size SRFL-D	
	3600	
A	2249,1 88.55	
B	1392,8 54.84	
C	1368,1 53.86	
D	325 12.80	
E	739 29.11	
G	1479 58.22	
H	252 9.92	
I	425 16.73	
K	540 21.26	
L	480 18.90	
M	480 18.90	
N	540 21.26	
O	23 .91	
P	281,4 11.08	
R	60 2.36	
Total Oil Capacity (l/gal)	233 61.3	
Weight (kg/lbs)	390 860	
Filter Elements	Designation	RE-600 ...
	Quantity	2 x 6

E

In-Line Filter Housings / Complete Filters ▪ Type SRFL-S / D

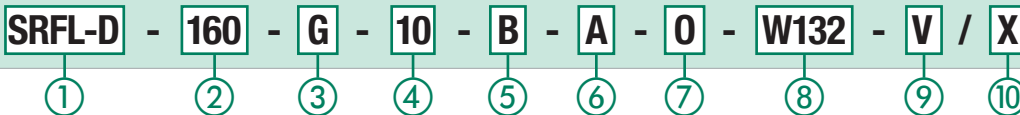

① Type

In-Line Simplex Housing	SRFL-S
In-Line Duplex Housing	SRFL-D

② Group

Flow	Size
900 l/min / 240 US GPM	160
900 l/min / 240 US GPM	200
1400 l/min / 370 US GPM	300
1400 l/min / 370 US GPM	600
4000 l/min / 1050 US GPM	1200
4000 l/min / 1050 US GPM	1800
6000 l/min / 1580 US GPM	2400
7000 l/min / 1850 US GPM	3600

③ Filter Material

Material	Max. Δp*collapse	Micron ratings available	Code
Without filter element	-	-	0
Inorg. glass fibre	25 bar / 363 PSI	3, 5, 10, 20	G
Stainless fibre	30 bar / 435 PSI		A
Filter paper	10 bar / 145 PSI	10, 20	N
Stainless mesh	30 bar / 435 PSI	25, 50, 100, 200	S

* Note: Collapse/burst resistance as per ISO 2941.
Other materials on request.

④ Micron Rating

3 µm	03
5 µm	05
10 µm	10
20 µm	20
25 µm	25
50 µm	50
100 µm	100
200 µm	200

Note: Other micron ratings on request.

⑤ Sealing Material

NBR (Buna®)	B
FKM (Viton®)	V

Note: Other sealing materials on request.

⑩ Design Code

Only for information	X
----------------------	----------

⑥ Connection Style

Connection Style	Group								Code
	160	200	300	600	1200	1800	2400	3600	
DIN Flange	DN 40	DN 50	DN 65	DN 80	DN 100	DN 125	DN 150	DN 200	D
ANSI Flange	1-1/2	2	2-1/2	3	4	5	6	8	A
SAE Flange	1-1/2	2	2-1/2	3	4	5	-	-	S

⑦ Connection Location

Opposite side*	0
Same side	S

* Note: Not for SRFL-D series

⑧ Housing Material

Carbon Steel	W132
Stainless Steel	W4

⑨ Clogging Indicator

Without Clogging Indicator	0
Differential Pressure Switch with Visual Gauge Indicator	V

Note: Other indicators on request.

Filter Elements ▪ Type RE

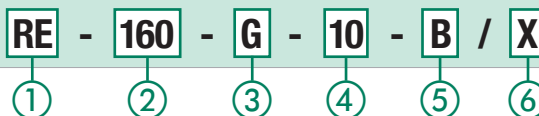

① Type

Filter Element Series	RE
-----------------------	-----------

② Group

Designation	Filter Element Quantity		Size
	SRFL-S	SRFL-D	
RE-160	1x1	2x1	160
RE-200	1x1	2x1	200
RE-300	1x1	2x1	300
RE-600	1x1	2x1	600
RE-600	1x2	2x2	1200
RE-600	1x3	2x3	1800
RE-600	1x4	2x4	2400
RE-600	1x6	2x6	3600

③ Filter Material

Material	Max. Δp*collapse	Micron ratings available	Code
Inorg. glass fibre	25 bar / 363 PSI	3, 5, 10, 20	G
Stainless fibre	30 bar / 435 PSI		A
Filter paper	10 bar / 145 PSI	10, 20	N
Stainless mesh	30 bar / 435 PSI	25, 50, 100, 200	S

* Note: Collapse/burst resistance as per ISO 2941.
Other materials on request.

④ Micron Rating

3 µm	03
5 µm	05
10 µm	10
20 µm	20
25 µm	25
50 µm	50
100 µm	100
200 µm	200

Note: Other micron ratings on request.

⑤ Sealing Material

NBR (Buna®)	B
FKM (Viton®)	V

Note: Other sealing materials on request

⑥ Design Code

Only for information	X
----------------------	----------

Return-Line Filters ■ Type SRFL-S / D

Differential Pressure Switch with Visual Gauge Indicator

The switch is used to indicate when the elements need to be changed. The switch can turn on a light, shut down the machine or any further function controlled by an electrical signal. The gauge visually indicates the differential pressure across the filter elements.

Diameter

- 100 mm / 3.94 in

Scale

- 0 ... 1,6 kg/cm²

Connection Thread

- G1/4

Operating Pressure

- Max. 200 bar / 2900 PSI

Temperature Range

- -20 °C ... +80 °C / -4 °F ... +176 °F

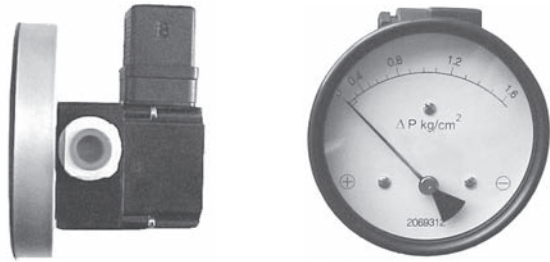
Materials

- Body: Aluminium
- Lens: Glass
- Sealing Material: NBR (Buna-N®)
FKM (Viton®)

Protection Rating

- IP 65: Dust tight and protected against water jets.

Switch Voltage

- Max. 28 V AC/DC

Current On Contact

- Max. 0,25 A

Contact Rating

- 5 VA AC/DC

In-Line Filters ■ Type SRFL-S / D Flow Characteristics

The following characteristics are valid for mineral oils with a density of 0,85 kg/dm³ and the kinematic viscosity of 30 mm²/s (30cSt). The characteristics have been determined in accordance to ISO 3968. Multipass filter ratings have been obtained in accordance to ISO 16889. The housing pressure drop is directly proportional to the oil density. Contact STAUFF for details.

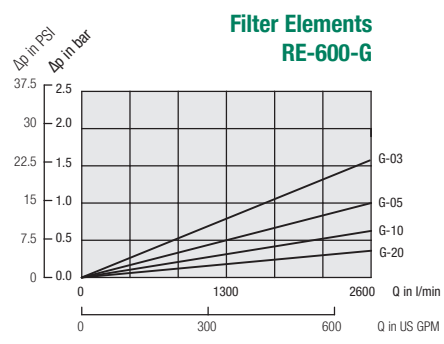
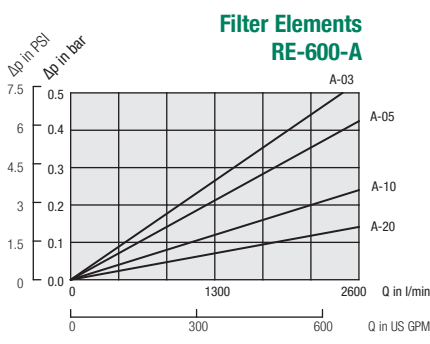
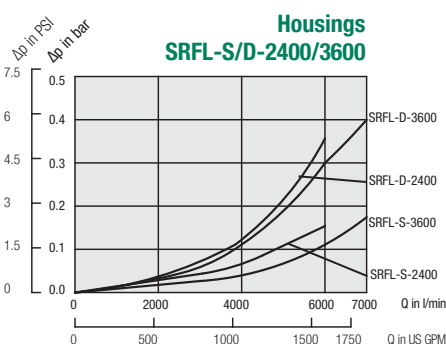
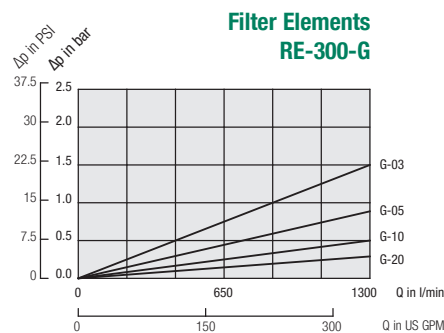
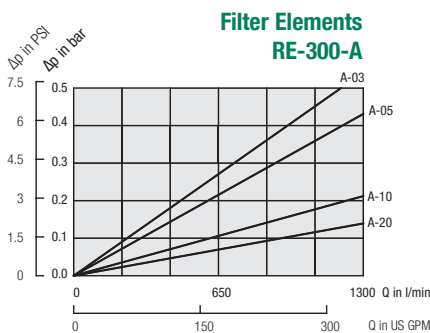
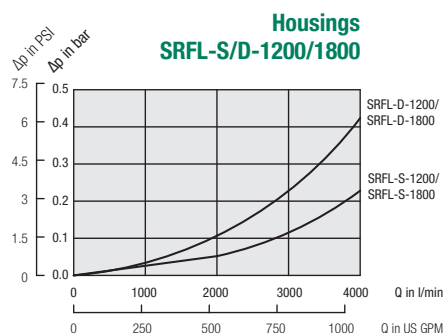
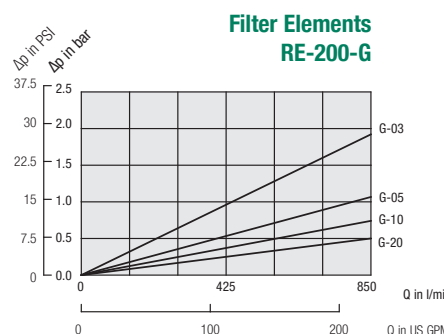
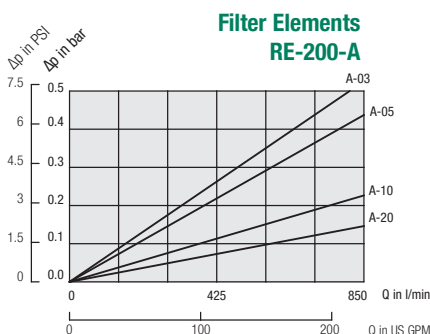
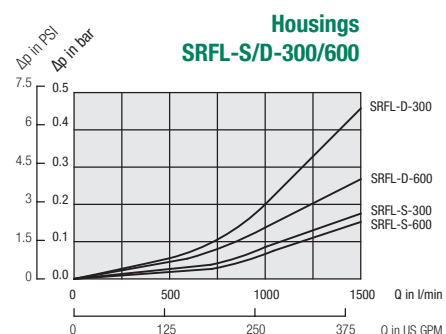
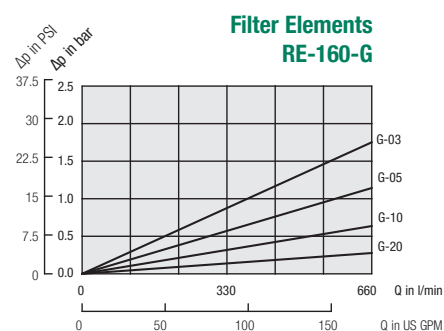
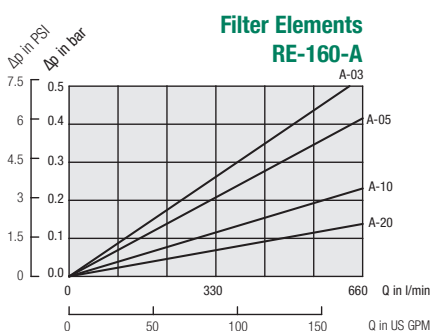
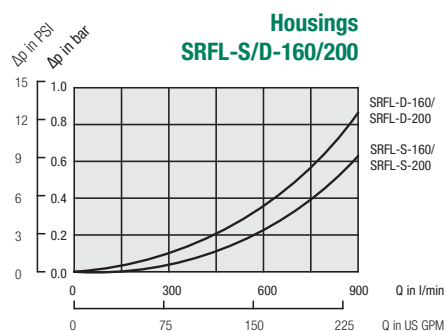

Pressure drop of housing including filter elements

General: $\Delta p_{total} = \Delta p_{housing} + \Delta p_{Element} \times (\text{operating viscosity [mm}^2\text{/s]} / 30\text{mm}^2\text{/s})$

with $\Delta p_{housing}$ = See diagrams above

$\Delta p_{Element}$ = pressure drop of element at a flow Q/n (at a viscosity of 30 mm²/s and n = numbers of elements as listed in ordering code filter elements see page 140 and diagrams above.)

Example

Data given Q_{max} = 6000 l/min / 1585 US GPM, SRFL-D-2400 with filter elements RE-600-S-25-B;
operating viscosity = 100 mm²/s
 Q_{max} = 6000 l/min; n=4 elements (SRFL-D-2400) Q/n=1500 l/min / 396 gal
 $\Delta p_{housing}$ = 0,35 bar / 5.07 PSI, $\Delta p_{Element}$ = 0,03 bar / 0.44 PSI

Pressure drop: $\Delta p_{total} = 0,35 \text{ bar} + 0,03 \text{ bar} \times (100 \text{ mm}^2\text{/s} / 30\text{mm}^2\text{/s})$
= 0,45 bar / 6.53 PSI

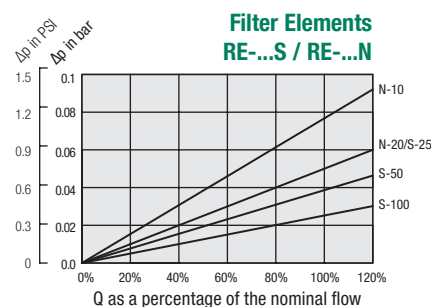

In-Line Filters ■ Type SRFL-SW



E

Product Description

STAUFF In-Line Filters SRFL-SW are specially developed for direct installation into the pipelines of industrial water cycles. Depending on their size, SRFL-SW filter housings are suitable for nominal flow rates up to 13330 l/min / 3521 US GPM at a maximum operating pressure of 16 bar / 232 PSI. The SRFL-SW have been designed to be used in the steel industry for pre-filtering or coarse filtering in descaling plants. For use with demineralised water we recommend the In-Line Filters SRFL-SW in Stainless Steel. The filter element construction as a Stainless Steel basket screen filter ensures a long service life.

Technical Data

Construction

- Designed for direct installation into pipelines
- Simplex version, Duplex on request

Materials

- Filter housing: Carbon Steel
Stainless Steel (on request)
- Sealing: PTFE / NBR (Buna-N®)
PTFE / FKM (Viton®)

Port Connections

- ANSI or DIN flange

Operating Pressure

- Max. 16 bar / 232 PSI

Flow Rating

- Max. 13330 l/min / 3521 US GPM

Temperature Range

- -10 °C ... +100 °C / +14 °F ... +212 °F

Media Compatibility

- Water
- Coolant
- Others on request

Options and Accessories

Filter Elements

Stainless Steel basket screen filters from STAUFF's REL product line are used as filter elements, which are designed for flow from the inside to the outside. The filter elements are available in micron ratings between 50 µm and 200 µm. Solid particles collected in the basket are prevented from reaching the clean side of the water cycle when being replaced.

Clogging Indicator

- Differential Pressure Gauge
- visual / electrical / visual-electrical (see page 54)

Drain Valve

- Available as an option: Integrated into the filter housing

In-Line Filters ■ Type SRFL-SW-160 /-300 /-600

Version with handle

* recommended space for element change

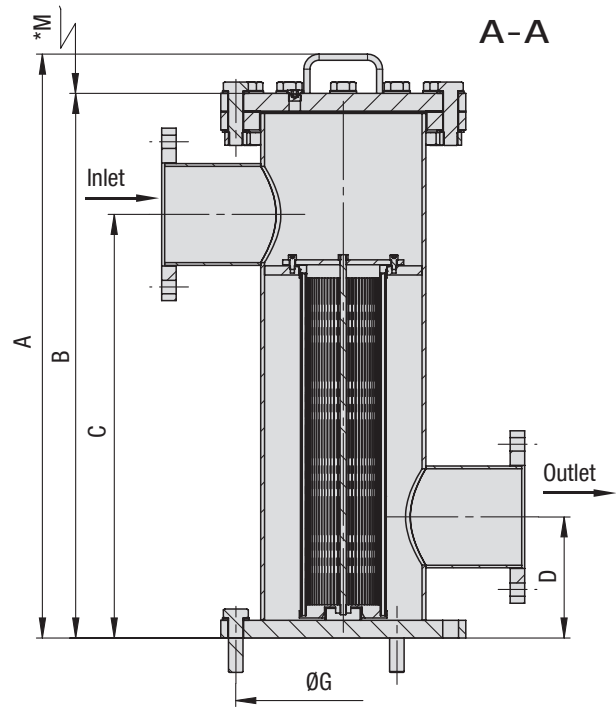
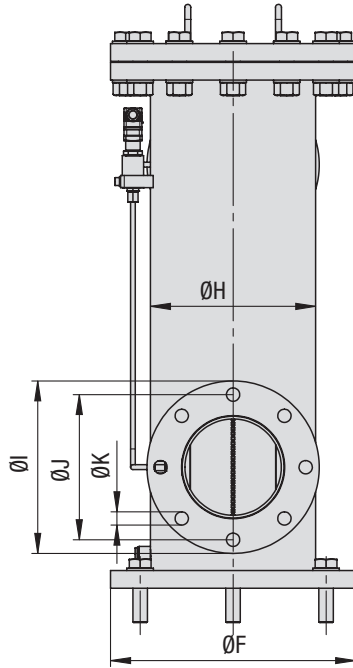

Detail arrangement of filter elements

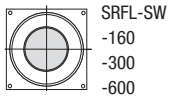

Flange Connection	Filter Size SRFL-SW		
	160	300	600
DIN	DN80	DN100	DN150
	DN50	DN125	-
ANSI	2	4	6
	3	5	-

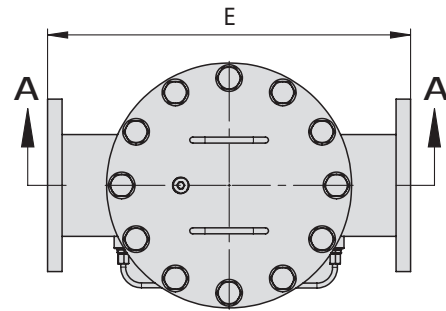

Dimensions (mm/in)	Filter Size SRFL-SW		
	160	300	600
Filter Housing Material	CS/SS		
	CS/SS	CS/SS	CS/SS
A	840 33.07	965 38.00	965 38.00
B	775 30.51	900 35.43	900 35.43
C	600 23.62	700 27.56	700 27.56
D	250 9.84	200 7.87	200 7.87
E	440 17.32	500 19.69	600 23.62
ØF	340 13.39	340 13.39	405 15.94
ØG	295 11.61	295 11.61	355 13.98
ØH	219,1 8.63	219,1 8.63	273 10.75
ØI	200 7.87	220 8.66	285 11.22
ØJ	160 6.30	180 7.09	240 9.45
ØK	18 .71	18 .71	22 .87
M	400 15.75	650 25.60	650 25.60
Housing Capacity (l / US GPM)	26,2	31,3	52,9
	6.9	8.3	14
Filter Elements	Designation	REL-100	REL-100
	Quantity	1	1

In-Line Filters ■ Type SRFL-SW-850 /-1000 /-1250
Version with lifting device

* recommended space for element change

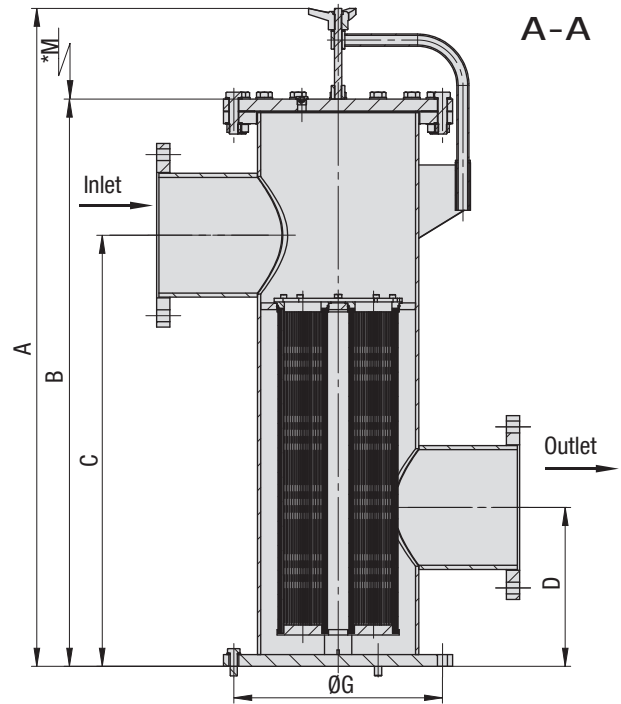
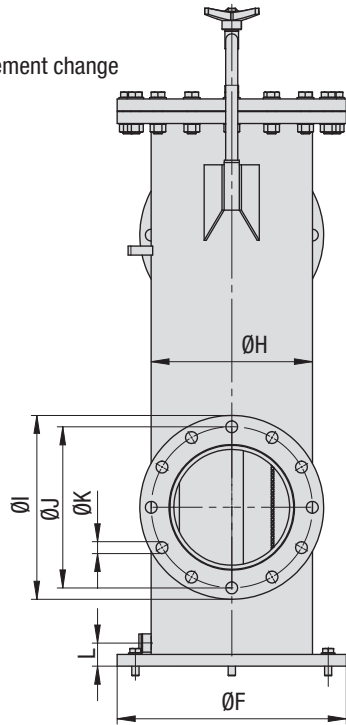
Detail arrangement for filter elements

SRFL-SW-850

SRFL-SW-1000

SRFL-SW-1250

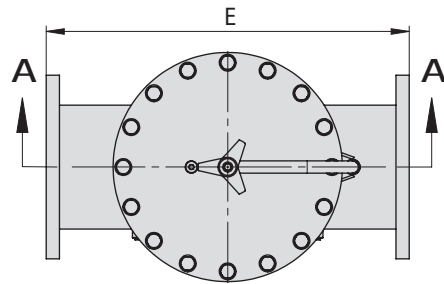

Flange Connection	Filter Size SRFL-SW		
	850	1000	1250
DIN	DN200 DN150	DN250	DN300
ANSI	8	10	12
	-	-	-

Dimensions (mm/in)	Filter Size SRFL-SW					
	850		1000		1250	
Filter Housing Material	CS	SS	CS	SS		
A	1154 45.43	1150 45.28	1442 56.77	1450 57.09	1950 76.77	
B	962 37.87	950 37.40	1250 49.21	1250 49.21	1740 68.50	
C	750 29.53	750 29.53	950 37.40	950 37.40	1400 55.12	
D	300 11.81	300 11.81	350 13.78	350 13.78	400 15.75	
E	700 27.56	700 27.56	800 31.50	800 31.50	1100 43.31	
ØF	520 20.47	505 19.88	520 20.47	505 19.88	640 25.20	
ØG	470 18.50	460 18.11	470 18.50	460 18.11	585 23.03	
ØH	355,6 14.00	355,6 14.00	355,6 14.00	355,6 14.00	508 20.00	
ØI	340 13.39	340 13.39	405 15.94	405 15.94	460 18.11	
ØJ	295 11.61	295 11.61	355 13.98	355 13.98	410 16.14	
ØK	22 .87	22 .87	26 1.02	26 1.02	26 1.02	
M	650 25.59	650 25.59	850 33.46	850 33.46	850 33.46	
L	55 2.17	51 2.01	55 2.17	51 2.01	82 3.23	
Housing Capacity (l / US GPM)	96,5		138,6		392	
	25,5		36,6		103,6	
Filter Elements	Designation	REL-150	REL-150	REL-250	REL-250	REL-250
	Quantity	2	2	3	3	5

In-Line Filter Housing / Complete Filters ■ Type SRFL-SW

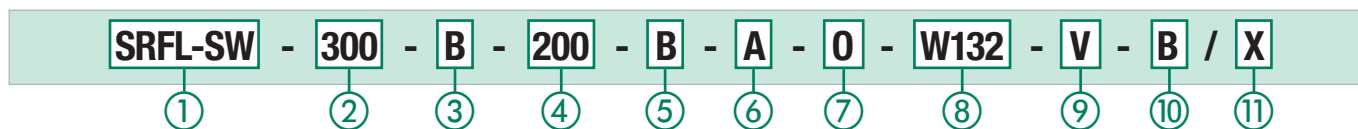

① Type

In-Line Filter Simplex Water **SRFL-SW**

② Group

Flow	Size
650 l/min / 160 US GPM	160
1200 l/min / 300 US GPM	300
2500 l/min / 600 US GPM	600
6000 l/min / 1500 US GPM	850
8300 l/min / 2000 US GPM	1000
13330 l/min / 3300 US GPM	1250

③ Filter Material

Material	Micron Ratings Available	Code
Without filter element	-	0
Stainless mesh	50, 80, 100, 125, 200	B

④ Micron Rating

50 µm	50
80 µm	80
100 µm	100
125 µm	125
200 µm	200

Note: Other micron ratings on request.

⑤ Sealing Material

PTFE / NBR (Buna®)	B
PTFE / FKM (Viton®)	V

Note: Other sealing materials on request.

⑥ Connection Style

Connection Style	Group						Code
	160	300	600	850	1000	1250	
DIN flange	DN80	DN100	DN150	DN200	DN250	DN300	D
	DN50	DN125	-	DN150	-	-	D1
ANSI flange	2"	4"	6"	8"	10"	12"	A
	3"	5"	-	-	-	-	A1

⑦ Connection Location

Opposite side	0
---------------	----------

⑧ Housing Material

Carbon Steel	W132
Stainless Steel	W4

⑨ Clogging Indicator

Without Clogging Indicator	0
Differential Pressure Gauge	V

Note: Other clogging indicators on request.

⑩ Drain Valve

Closed	0
Ball Valve	B

⑪ Design Code

Only for information	X
----------------------	----------

Filter Elements ■ Type REL

Product Description

Stainless Steel basket screen filters from STAUFF's REL product line are used as filter elements, which are designed for flow from the inside to the outside. Micron ratings ranging from 50 µm to 200 µm are available. Solid particles collected in the basket are prevented from reaching the clean side of the water cycle when being replaced. The filter element construction as a Stainless Steel basket screen filter ensures a long service life.

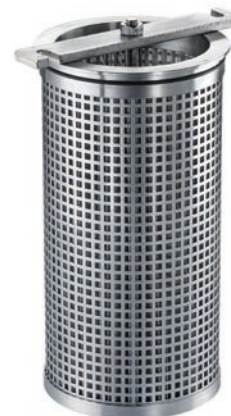

Order Code

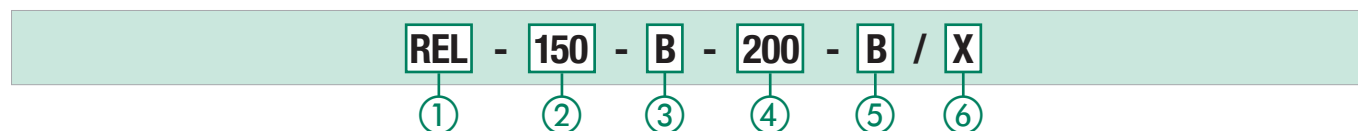

① Type

Filter Element Series **REL**

② Group

Designation	Number of Filter Elements	Size
REL-100	1	160
REL-150	1	300
REL-150	1	600
REL-150	2	850
REL-250	3	1000
REL-250	5	1250

③ Filter Material

Material	Max. Δp*Collapse	Micron Ratings Available	Code
Stainless mesh	10 bar / 145 PSI	50, 80, 100, 125, 200	B

④ Micron Rating

50 µm	50
80 µm	80
100 µm	100
125 µm	125
200 µm	200

⑤ Sealing Material

NBR (Buna®)	B
FKM (Viton®)	V

⑥ Design Code

Only for information	X
----------------------	----------

Differential Pressure Gauge

A visual clogging indicator, the function of which is based on the differential pressure between the contaminated and clean side of the filter elements, is available as an option, and enables a convenient determination of the condition of the basket filter.

Nominal Size

- 80 mm / 3.15 in

Range of Scale

- 0 ... 1 bar / 0 ... 14.5 PSI

Operating Pressure

- Max. 100 bar / 1450 PSI

Permissible Temperatures

- Ambient: 0 ... +60 °C / 0 ... +140 °F
- Media: up to +100 °C / +212 °F

Material

- Housing: Die-cast Aluminium, black
- Sight glass: Acrylic
- Indicator: Aluminium, black

Protection Rating

- IP 54 protection rating: Dust protected and protected against splashing water



Overview Spin-On Filters

150

Quick Reference Guide

 Spin-On Filter Heads
 Spin-On Filter Elements

151

Spin-On Filter Heads

152 - 158

SLF-02 / 03 / 04
 Max. 14 bar / 200 PSI
 Max. 26 l/min / 7 US GPM

152

SAF-05 / 06 / 07 / 11
 Max. 14 bar / 200 PSI
 Max. 90 l/min / 25 US GPM

153

SAF-10 / 13
 Max. 14 bar / 200 PSI
 Max. 128 l/min / 34 US GPM

154

SSF-12
 Max. 12 bar / 174 PSI
 Max. 90 l/min / 25 US GPM

155

SSF-20L
 Max. 12 bar / 174 PSI
 Max. 225 l/min / 60 US GPM

156

SSF-100 / 120 / 120L / 130 / 160
 Max. 14 bar / 200 PSI
 Max. 225 l/min / 60 US GPM

157

SSF-150 / 180
 Max. 14 bar / 200 PSI
 Max. 300 l/min / 80 US GPM

158

Double Spin-On Filter Heads

159 - 163

SSF-24B
 Max. 12 bar / 174 PSI
 Max. 454 l/min / 120 US GPM

159

SSF-24N / 24S
 Max. 12 bar / 174 PSI
 Max. 454 l/min / 120 US GPM

160

SSF-25B
 Max. 12 bar / 174 PSI
 Max. 454 l/min / 120 US GPM

161

SSF-25FM
 Max. 12 bar / 174 PSI
 Max. 454 l/min / 120 US GPM

162

SSF-25
 Max. 12 bar / 174 PSI
 Max. 454 l/min / 120 US GPM

163

Tank Top Spin-On Filter Heads

164 - 167

SSFT-12B
 Max. 7 bar / 100 PSI
 Max. 75 l/min / 20 US GPM

164

SSFT-12
 Max. 7 bar / 100 PSI
 Max. 75 l/min / 20 US GPM

165

SSFT-20B
 Max. 7 bar / 100 PSI
 Max. 200 l/min / 53 US GPM

166

SSFT-20
 Max. 7 bar / 100 PSI
 Max. 200 l/min / 53 US GPM

167

Spin-On Filter Elements

168 - 173

Overview Spin-On Filter Elements

168

 SFC-35 / 36
 SFCT-35 / 36

169

 SFC-57 / 58
 SFCT-57 / 58

170



SF-63

171



SF-65

172



SF-67

173

Flow Characteristics

174 - 176

 SFC/SFCT-35 / 36
 SFC/SFCT-57 / 58
 SF-63

174

SF-65

175

SF-67

176

Clogging Indicators

177

Description

STAUFF provides a complete range of Spin-On Filters which can be used either as Suction-Line filters or as Return-Line filters for low pressure applications. The various ranges meet international standards.

Material

- Filter head: Aluminium

Media Compatibility

- Mineral oils, others on request

Connections

- BSP
- NPT
- SAE flange
- SAE thread
- Other ports connections on request

Operating Pressure

- Max. 14 bar / 200 PSI

Temperature Range

- -30 °C ... +100 °C / -22 °F ... +212 °F

Nominal Flow Rate

- Max. 460 l/min / 120 US GPM

Options and Accessories

Clogging Indicators

- Visual clogging indicator with coloured segments
- Electrical clogging switch
- Other types are available on request

Private Labelling

- On request, the filter elements can be printed with a private label



Spin-On Filter Heads
designed for in-line assembly



Spin-On Filter Heads
designed for tank top assembly



Spin-On Double Filter Heads
designed for in-line assembly

Spin-On Filters ■ Quick Reference Guide

Type A

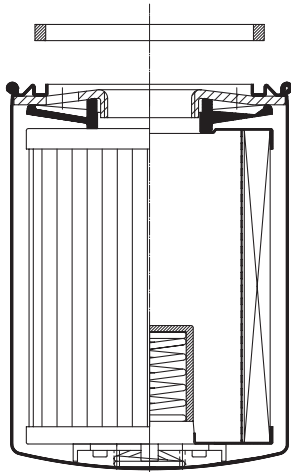
 Spin-On Filter with seal contour A
for filter elements with inner seal

A

Type B

 Spin-On Filter with seal contour B
for filter elements with outer seal

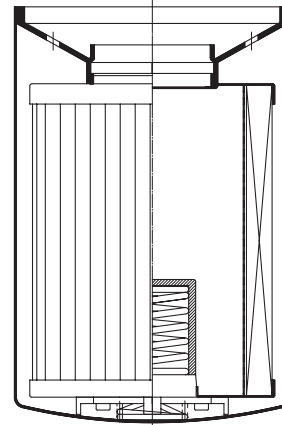
 Allowed seal types for Spin-On elements
 Thin seal
 Wide seal
 L-shaped seal

B

F

Spin-On Filters Quick Reference Guide

Spin-On Filter Heads

Spin-On Filter Elements (see page ...)

Series	Size	Port	Spigot	Max. Flow Rate*		Catalog Page	Seal Contour		SF-63	SF-65	SF-67	SFC-35 SFC-36	SFC-57 SFC-58	SFCT-35 SFCT-36	SFCT-57 SFCT-58
				l/min	US GPM		Type A	Type B							
SLF	02	1/4 NPT	3/4-16 UNF	19	5	152	x		171						
SLF	03	3/8 NPT	3/4-16 UNF	19	5	152	x		171						
SLF	04	9/16-18 UN	3/4-16 UNF	26	7	152	x		171						
SAF	05	1/2 NPT	1-12 UNF	57	15	153	x			172					
SAF	06	3/4-16 UN	1-12 UNF	57	15	153	x			172					
SAF	07	3/4 NPT	1-12 UNF	90	25	153	x			172					
SAF	11	1-1/16-12 UN	1-12 UNF	90	25	153	x			172					
SAF	10	1 NPT	1-12 UNF	128	34	154	x			172					
SAF	13	1-5/16-12 UN	1-12 UNF	128	34	154	x			172					
SSF	12	G3/4	G3/4	90	25	155	x					169			
SSF	20L	G1-1/4	G1-1/4 + 1-1/2-16 UN	225	60	156	x	x			173		170		
SSF	100	1 NPT	G1-1/4 + 1-1/2-16 UN	170	45	157	x	x			173		170		
SSF	120L	1-1/4 NPT	G1-1/4 + 1-1/2-16 UN	225	60	157	x	x			173		170		
SSF	120	1-1/4 NPT	G1-1/4 + 1-1/2-16 UN	225	60	157	x	x			173		170		
SSF	130	1-5/16-12 UN	G1-1/4 + 1-1/2-16 UN	225	60	157	x	x			173		170		
SSF	160	1-5/8-12 UN	G1-1/4 + 1-1/2-16 UN	225	60	157	x	x			173		170		
SSF	150	1-1/2 NPT	1-1/2-16 UN	300	80	158		x			173				
SSF	180	1-7/8-12 UN	1-1/2-16 UN	300	80	158		x			173				
SSF	24B	G1-1/2	G1-1/4 + 1-1/2-16 UN	454	120	159	x	x			173		170		
SSF	24N	1-1/2 NPT	G1-1/4 + 1-1/2-16 UN	454	120	160	x	x			173		170		
SSF	24S	1-7/8-12 UN	G1-1/4 + 1-1/2-16 UN	454	120	160	x	x			173		170		
SSF	25B	G1-1/2	G1-1/4	454	120	161	x	x			173		170		
SSF	25FM	1-1/2 SAE Flange	1-1/2-16 UN	454	120	162	x	x			173		170		
SSF	25	1-1/2 NPT and 2 SAE Flange	G1-1/4 + 1-1/2-16 UN	454	120	163	x	x			173		170		
SSFT	12B	G3/4	G3/4	75	20	164	x	x						169	
SSFT	12	3/4 NPT	G3/4	75	20	165	x	x						169	
SSFT	20B	G1-1/2	G1-1/4 + 1-1/2-16 UN	200	53	166	x								170
SSFT	20	1-1/2 NPT	G1-1/4 + 1-1/2-16 UN	200	53	167	x								170

* Note: Reflects nominal flow rate for Return-Line application. Actual flow rate will depend on selected element and the viscosity of the fluid.

Spin-On Filter Heads ■ SLF-02 / 03 / 04

Dimensions

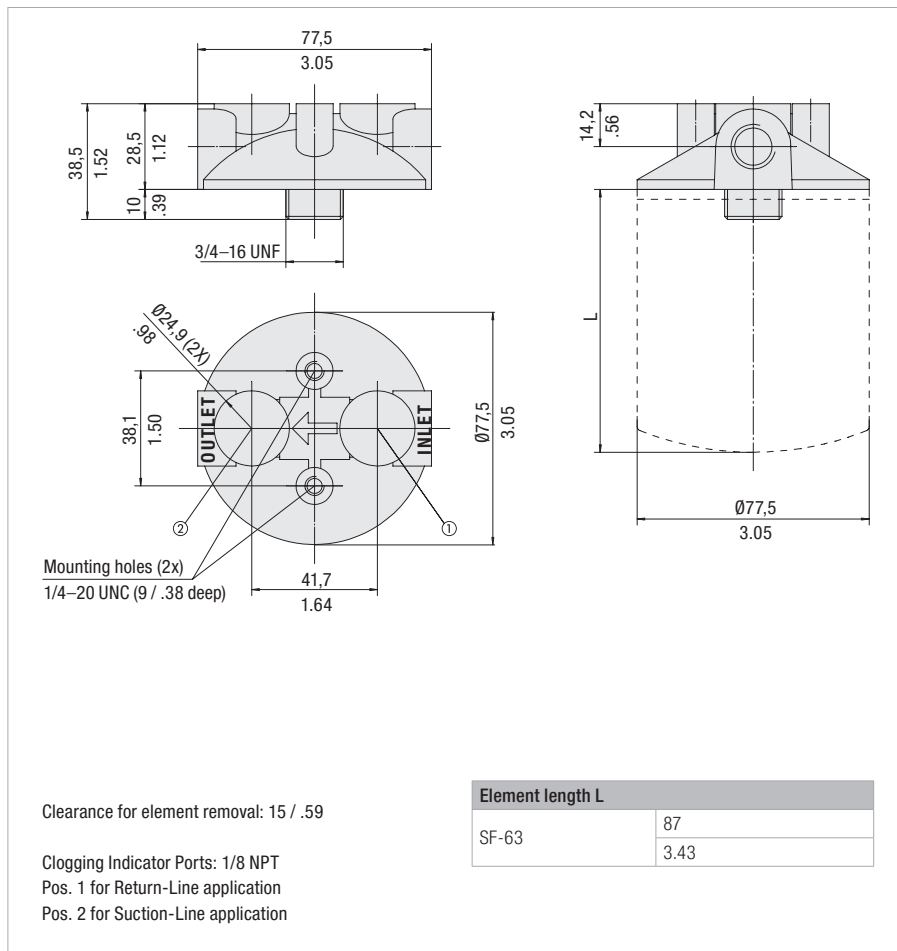

Dimensions in mm / in

Technical Data

Construction

- In-line Spin-On filter head

Material

- Aluminium

Port Connections

- NPT
- SAE O-ring thread

Flow Rate

- 26 l/min / 7 US GPM for Return-Line application
- 7 l/min / 2 US GPM for Suction-Line application

Operating Pressure

- Max. 14 bar / 200 PSI
- Max. 5,5 bar / 80 PSI differential pressure (for any application without bypass valve)

Temperature Range

- -30 °C ... +100 °C / -22 °F ... +212 °F

Media Compatibility

- Mineral oils, other fluids on request

Options and Accessories



Filter Elements

- For use with SF-63 series elements
- For element types with seal contour type A
- For element types and flow characteristics see page 174
- The element is not part of the scope of delivery

Order Code

SLF - 02 - 0
1 2 3

① Type

Spin-On Filter Head	SLF
---------------------	------------

② Connection Style

Connection	Thread	Code
NPT	1/4	02
NPT	3/8	03
SAE	9/16-18	04

③ Clogging Indicator Port Options

No clogging indicator port	0
Special	9

Note: Standard clogging indicator port is 1/8 NPT.

Spin-On Filter Heads ■ SAF-05 / 06 / 07 / 11

Dimensions

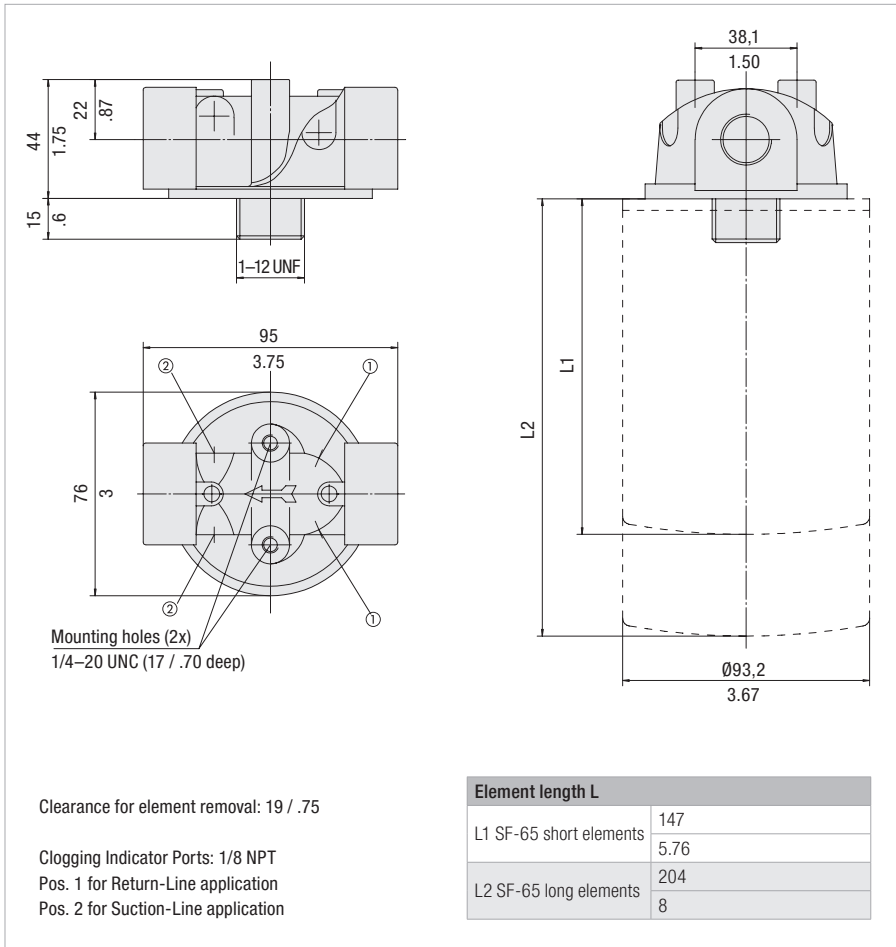

Technical Data

Construction

- In-line Spin-On filter head

Material

- Aluminium

Port Connections

- NPT
- SAE O-ring thread

Flow Rate

- 90 l/min / 25 US GPM for Return-Line application
- 23 l/min / 6 US GPM for Suction-Line application

Operating Pressure

- Max. 14 bar / 200 PSI
- Max. 5,5 bar / 80 PSI differential pressure (for any application without bypass valve)

Temperature Range

- -30 °C ... +100 °C / -22 °F ... +212 °F

Media Compatibility

- Mineral oils, other fluids on request

Options and Accessories



Filter Elements

- For use with SF-65 series elements
- For element types with seal contour type A
- For element types and flow characteristics see page 175
- The element is not part of the scope of delivery

Valve

- Bypass valve (integrated in the head): Optional

Clogging Indicators

- For clogging indicator types see page 177

Order Code

SAF - 07 - B1.7 - 0

1 2 3 4

① Type

Spin-On Filter Head **SAF**

② Connection Style

Connection	Thread	Code
NPT	1/2	05
SAE	3/4-16	06
NPT	3/4	07
SAE	1-1/16-12	11

③ Bypass Options

No bypass	0
0,2 bar / 3 PSI	B0.2
0,35 bar / 5 PSI	B0.35
1 bar / 15 PSI	B1.0
1,7 bar / 25 PSI	B1.7

④ Clogging Indicator Port Options

No clogging indicator port	0
Clogging indicator port drilled for Return-Line application	1
Clogging indicator port drilled for Suction-Line application	2
All clogging indicator ports drilled	4
Special	9

Note: Standard clogging indicator port is 1/8 NPT.

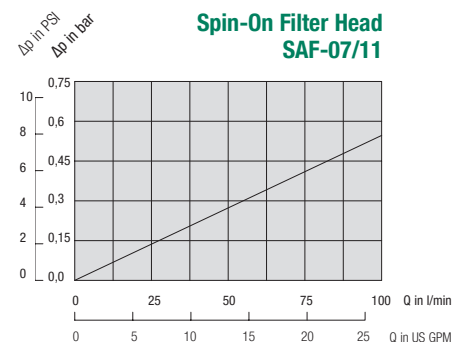
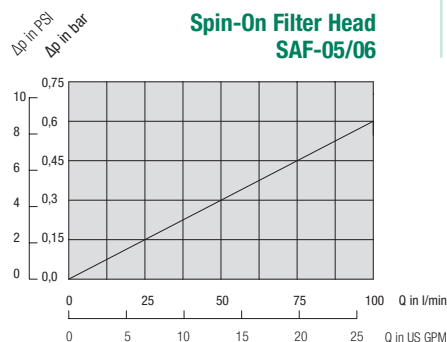

Spin-On Filter Heads ■ SAF-10 / 13



Technical Data

Construction

- In-line Spin-On filter head

Material

- Aluminium

Port Connections

- NPT
- SAE O-ring thread

Flow Rate

- 128 l/min / 34 US GPM for Return-Line application
- 30 l/min / 8 US GPM for Suction-Line application

Operating Pressure

- Max. 14 bar / 200 PSI
- Max. 5,5 bar / 80 PSI differential pressure (for any applicaton without bypass valve)

Temperature Range

- -30 °C ... +100 °C / -22 °F ... +212 °F

Media Compatibility

- Mineral oils, other fluids on request

Options and Accessories



Filter Elements

- For use with SF-65 series elements
- For element types with seal contour type A
- For element types and flow characteristics see page 175
- The element is not part of the scope of delivery

Valve

- Bypass valve (integrated in the filter head): Optional

Clogging Indicators

- For clogging indicator types see page 177

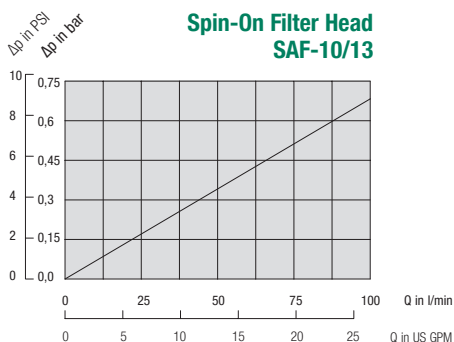

Dimensions

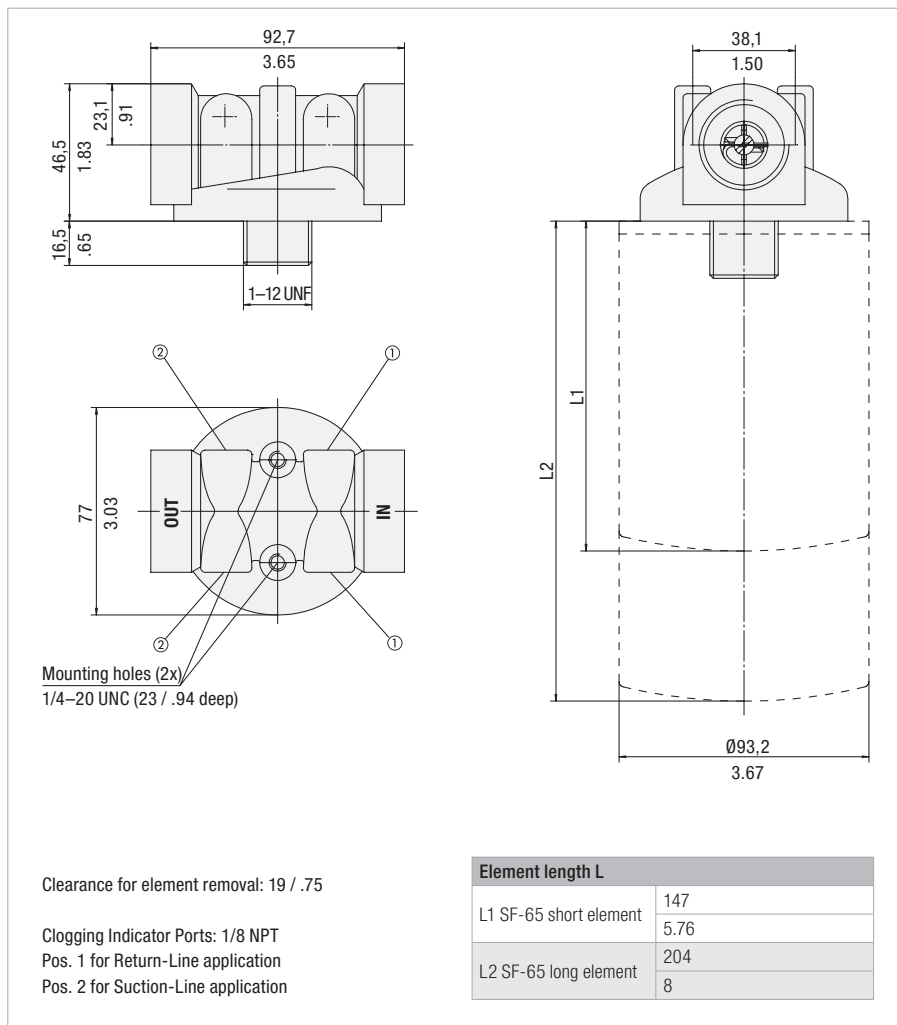

Dimensions in mm / in

Order Code

SAF - 10 - B1.7 - 0

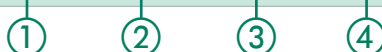

① Type

Spin-On Filter Head	SAF
---------------------	------------

② Connection Style

Connection	Thread	Code
NPT	1	10
SAE	1-5/16-12	13

③ Bypass Options

No bypass	0
0,2 bar / 3 PSI	B0.2
0,35 bar / 5 PSI	B0.35
1 bar / 15 PSI	B1.0
1,7 bar / 25 PSI	B1.7

④ Clogging Indicator Port Options

No clogging indicator port	0
Clogging indicator port drilled for Return-Line application	1
Clogging indicator port drilled for Suction-Line application	2
All clogging indicator ports drilled	4
Special	9

Note: Standard clogging indicator port is 1/8 NPT.

Spin-On Filter Heads ■ SSF-12

Dimensions

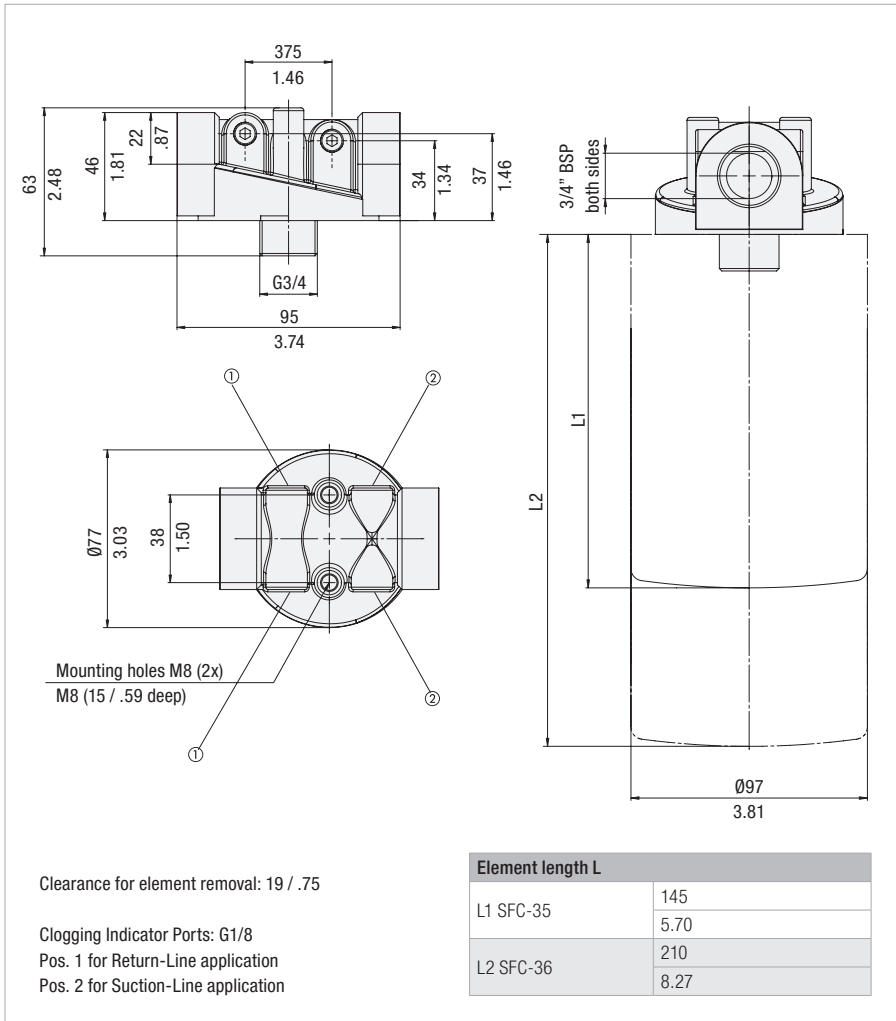

Dimensions in mm / in



Technical Data

Construction

- In-line Spin-On filter head

Material

- Aluminium

Port Connections

- BSP

Flow Rate

- 90 l/min / 25 US GPM for Return-Line application
- 23 l/min / 6 US GPM for Suction-Line application

Operating Pressure

- Max. 12 bar / 174 PSI
- Max. 5 bar / 72.5 PSI differential pressure (for any applicaton without bypass valve)

Temperature Range

- -30 °C ... +100 °C / -22 °F ... +212 °F

Media Compatibility

- Mineral oils, other fluids on request

Options and Accessories



Filter Elements

- For use with SFC-35/36 series elements
- For element types with seal contour type A
- For element types and flow characteristics see page 174
- The element is not part of the scope of delivery

Valve

- Bypass valve (integrated in the filter head): Optional

Clogging Indicators

- For clogging indicator types see page 177

Order Code

SSF - 12 - B1.7 - 4 / X

1 2 3 4 5

① Type

Spin-On Filter Head	SSF
---------------------	-----

② Connection Style

Connection	Thread	Code
BSP	3/4	12

③ Bypass Options

No bypass	0
0,2 bar / 3 PSI	B0.2
1,7 bar / 25 PSI	B1.7

Note: Other settings available on request.

④ Clogging Indicator Port Options

All clogging indicator ports drilled	4
Special	9

Note: Standard clogging indicator port is G1/8.

⑤ Design Code

Only for information	X
----------------------	---

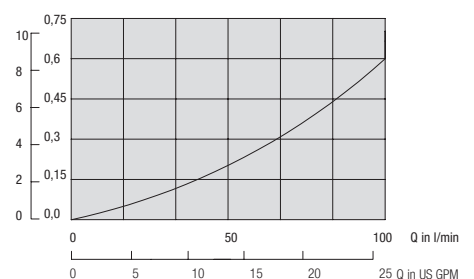
 Spin-On Filter Head
SSF-12

Spin-On Filter Heads - SSF-20L



Technical Data

Construction

- In-line Spin-On filter head

Material

- Aluminium

Port Connections

- BSP

Flow Rate

- 225 l/min / 60 US GPM for Return-Line application
- 46 l/min / 12 US GPM for Suction-Line application

Operating Pressure

- Max. 12 bar / 174 PSI
- Max. 5 bar / 72.5 PSI differential pressure (for any application without bypass valve)

Temperature Range

- 30 °C ... +100 °C / -22 °F ... +212 °F

Media Compatibility

- Mineral oils, other fluids on request

Options and Accessories



Filter Elements

- For use with SF-67 and SFC-57/58 series elements
- For element types with seal contour type A and B
- For element types and flow characteristics see page 176 for SF-67 and page 174 for SFC-57/58.
- The element is not part of the scope of delivery

Valve

- Bypass valve (integrated in the filter head): Optional

Clogging Indicators

- For clogging indicator types see page 177

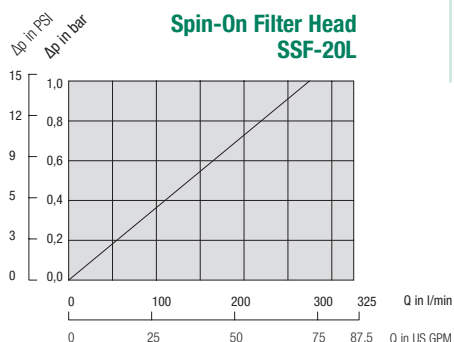

Spin-On Filter Head
SSF-20L

Dimensions

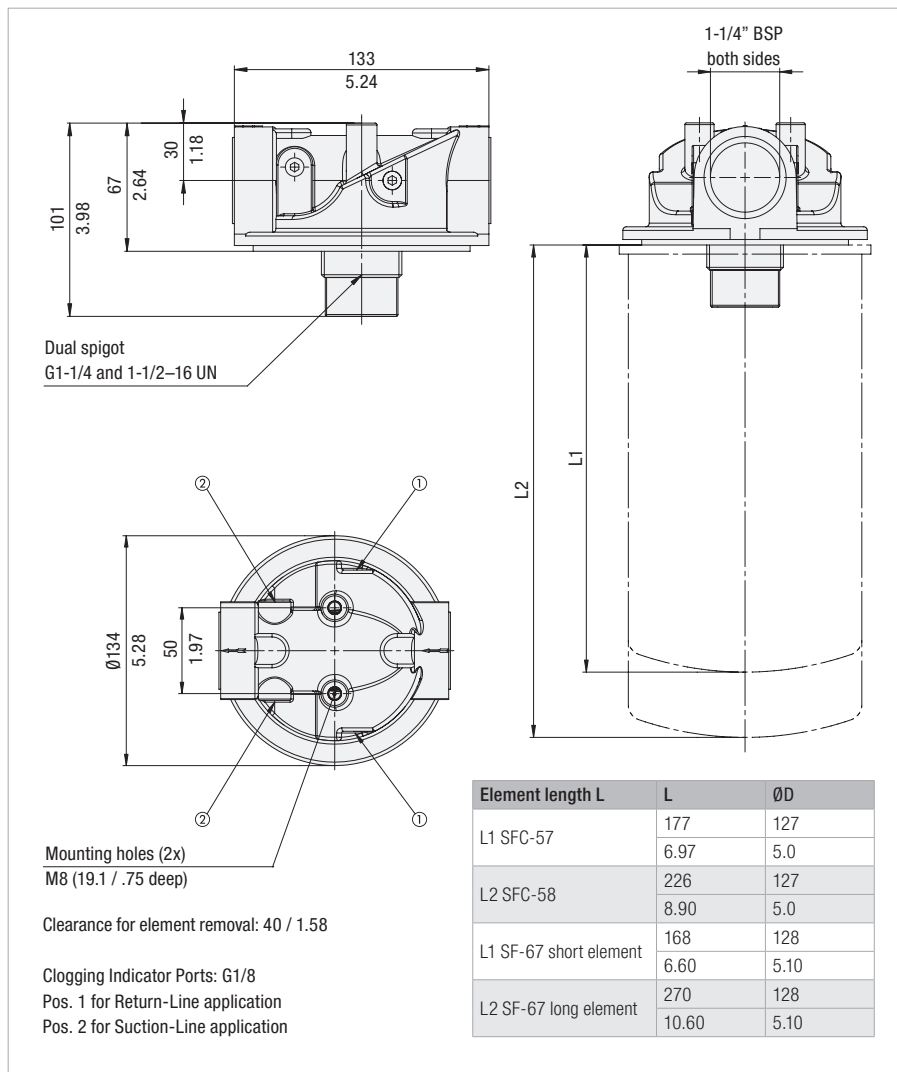

Dimensions in mm / in

Order Code

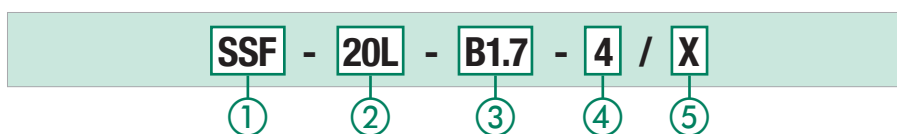

① Type

Spin-On Filter Head **SSF**

② Connection Style

Connection	Thread	Code
BSP	1-1/4	20L

③ Bypass Options

No bypass	0
0,2 bar / 3 PSI	B0.2
1,7 bar / 25 PSI	B1.7

Note: Other settings available on request.

④ Clogging Indicator Port Options

All clogging indicator ports drilled	4
Special	9

Note: Standard clogging indicator port for is G1/8.

⑤ Design Code

Only for information	X
----------------------	----------

Spin-On Filter Heads ■ SSF-100 / 120 / 120L / 130 / 160
Dimensions

50
1.97
93.5
3.68
61
2.4
28
1.10
Dual spigot
G1-1/4 and
1-1/2-16 UN

133
5.24
L1
L2
ØD

Ø133
5.24
①
②

Mounting holes (2x)
5/16-18 UNC
(19 / .75 deep)

Clearance for element removal: 40 / 1.58

Clogging Indicator Ports: 1/8 NPT
Pos. 1 for Return-Line application
Pos. 2 for Suction-Line application

Element length L	L	ØD
L1 SFC-57	177	127
	6.97	5.0
L2 SFC-58	226	127
	8.90	5.0
L1 SF-67 short element	168	128
	6.60	5.10
L2 SF-67 long element	270	128
	10.60	5.10

Dimensions in mm / in

Technical Data
Construction

- In-line Spin-On filter head

Material

- Aluminium

Port Connections

- NPT
- SAE O-ring thread

Flow Rate

- 225 l/min / 60 US GPM for Return-Line application
- 46 l/min / 12 US GPM for Suction-Line application

Operating Pressure

- Max. 12 bar / 174 PSI
- Max. 5 bar / 72.5 PSI differential pressure
(for any application without bypass valve)

Temperature Range

- -30 °C ... +100 °C / -22 °F ... +212 °F

Media Compatibility

- Mineral oils, other fluids on request

Options and Accessories

Filter Elements

- For use with SF-67 and SFC-57/58 series elements
- For element types with seal contour type A and B
- For element types and flow characteristics see page 176 for SF-67 and page 174 for SFC-57/58.
- The element is not part of the scope of delivery

Valve

- Bypass valve (integrated in the filter head): Optional

Clogging Indicators

- For clogging indicator types see page 177

Order Code

SSF - 120 - B1.7 - 0

① ② ③ ④

① Type

Spin-On Filter Head **SSF**

② Connection Style

Connection	Thread	Code
NPT	1	100
NPT	1-1/4	120L
NPT	1-1/4	120
SAE	1-5/16-12	130
SAE	1-5/8-12	160

③ Bypass Options

No bypass	0
0,2 bar / 3 PSI	B0.2
0,35 bar / 5 PSI	B0.35
1 bar / 15 PSI	B1.0
1,7 bar / 25 PSI	B1.7

④ Clogging Indicator Port Options

No clogging indicator port	0
Clogging indicator port drilled for Return-Line application	1
Clogging indicator port drilled for Suction-Line application	2
All clogging indicator ports drilled	4
Special	9

Note: Standard clogging indicator port is 1/8 NPT.

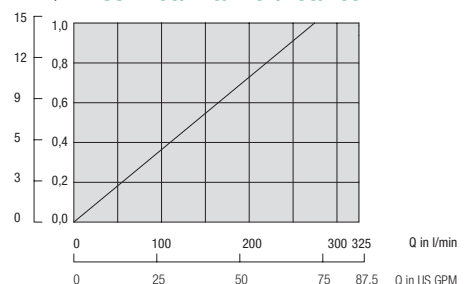
**Spin-On Filter Head
SSF-100/120/120L/130/160**

Spin-On Filter Heads ■ SSF-150 / 180

Dimensions

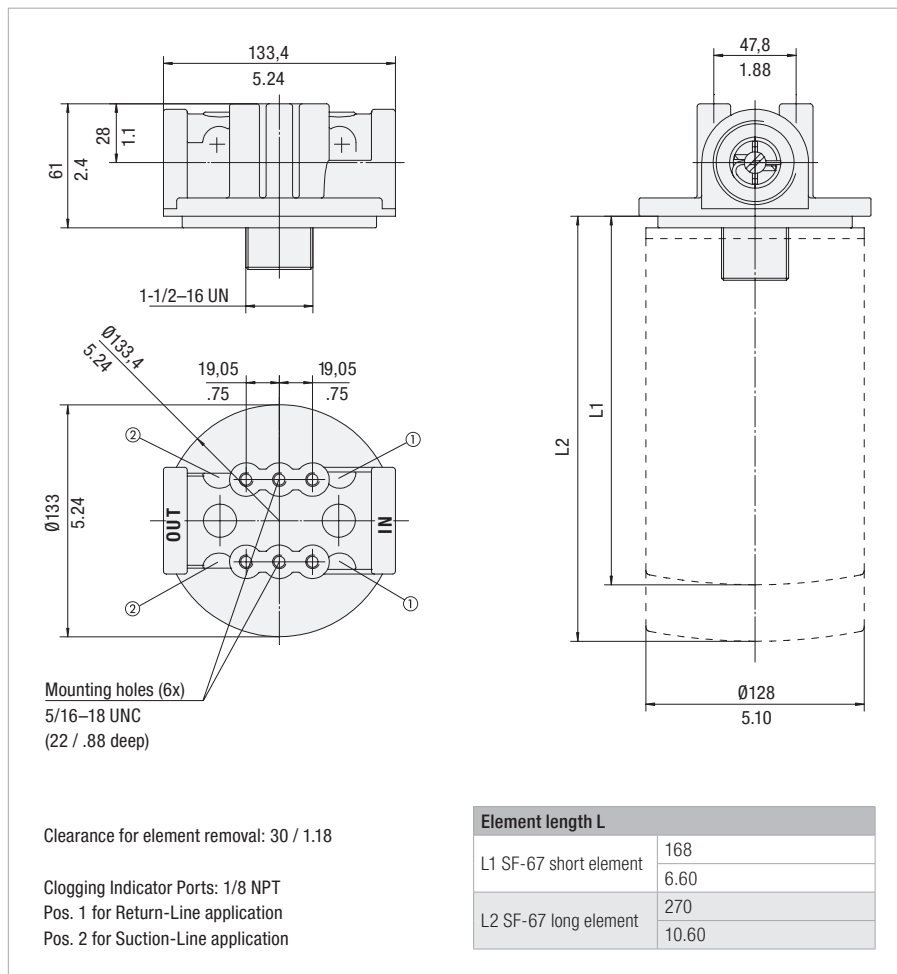

Dimensions in mm / in

Technical Data

Construction

- In-line Spin-On filter head

Material

- Aluminium

Port Connections

- NPT
- SAE O-ring thread

Flow Rate

- 300 l/min / 80 US GPM for Return-Line application
- 113 l/min / 30 US GPM for Suction-Line application

Operating Pressure

- Max. 14 bar / 200 PSI
- Max. 5,5 bar / 80 PSI differential pressure (for any applicaton without bypass valve)

Temperature Range

- -30 °C ... +100 °C / -22 °F ... +212 °F

Media Compatibility

- Mineral oils, other fluids on request

Options and Accessories



Filter Elements

- For use with SF-67 series elements
- For element types with seal contour type B
- For element types and flow characteristics see page 176
- The element is not part of the scope of delivery

Valve

- Bypass valve (integrated in the filter head): Optional

Clogging Indicators

- For clogging indicator types see page 177

Order Code

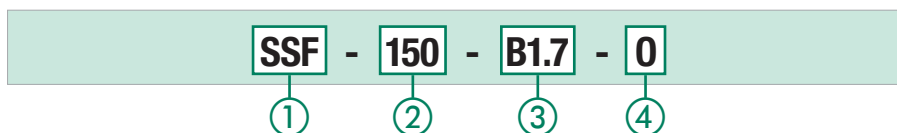

① Type

Spin-On Filter Head **SSF**

② Connection Style

Connection	Thread	Code
NPT	1-1/2	150
SAE	1-7/8-12	180

③ Bypass Options

No bypass	0
0,2 bar / 3 PSI	B0.2
0,35 bar / 5 PSI	B0.35
1 bar / 15 PSI	B1.0
1,7 bar / 25 PSI	B1.7

④ Clogging Indicator Port Options

No clogging indicator port	0
Clogging indicator port drilled for Return-Line application	1
Clogging indicator port drilled for Suction-Line application	2
All clogging indicator ports drilled	4
Special	9

Note: Standard clogging indicator port is 1/8 NPT.

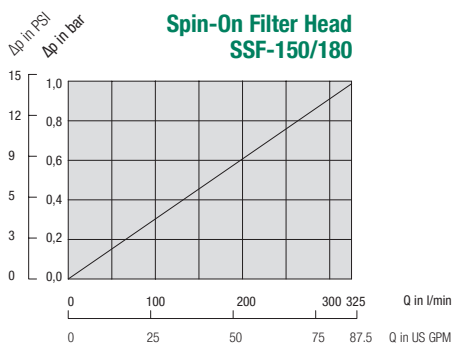

Double Spin-On Filter Heads ■ SSF-24B

Dimensions

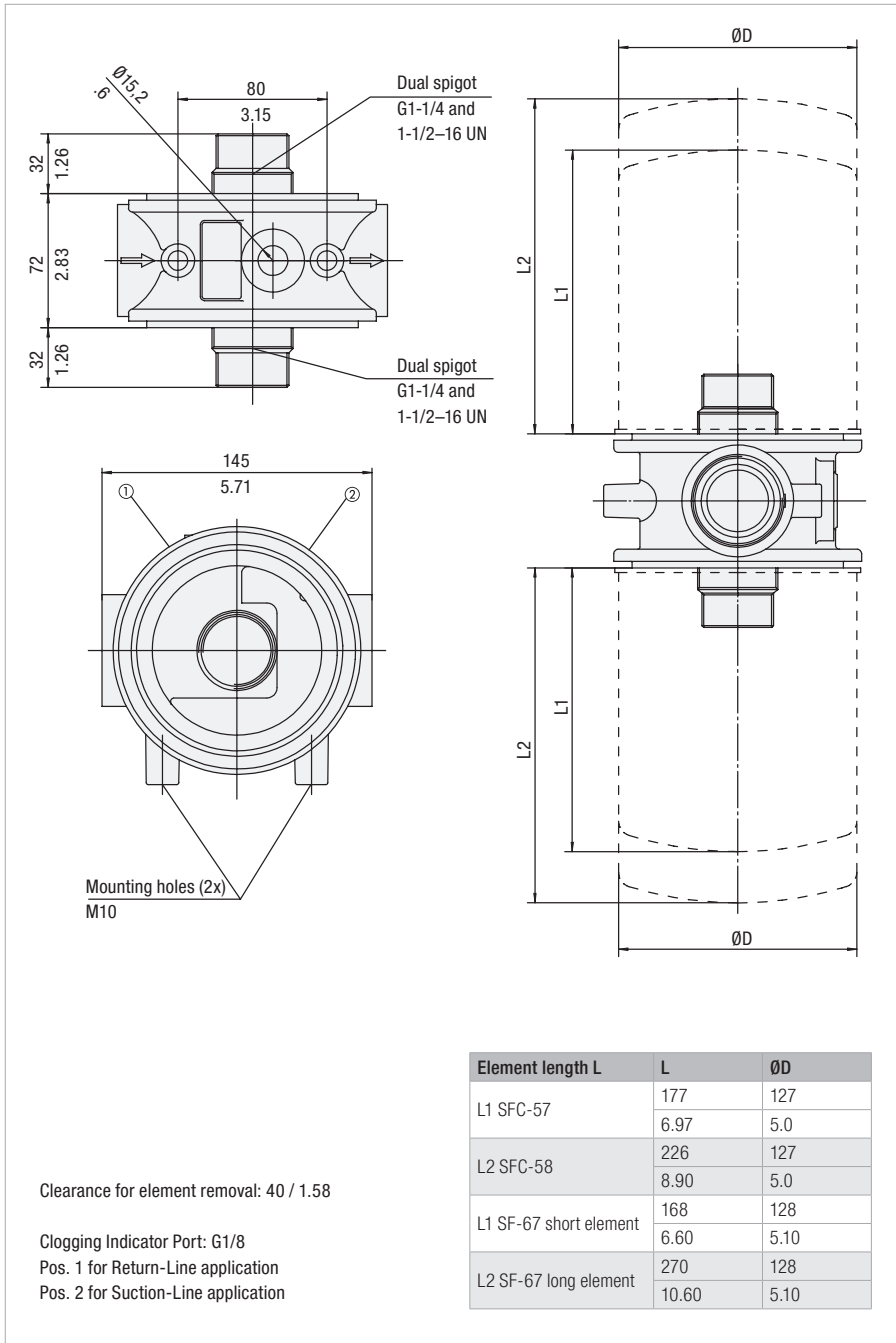

Dimensions in mm / in



Technical Data

Construction

- In-line Double Spin-On filter head

Material

- Aluminium

Port Connections

- BSP

Flow Rate

- 454 l/min / 120 US GPM for Return-Line application
- 132 l/min / 35 US GPM for Suction-Line application

Operating Pressure

- Max. 12 bar / 174 PSI
- Max. 5 bar / 72.5 PSI differential pressure (for any application without bypass valve)

Temperature Range

- -30 °C ... +100 °C / -22 °F ... +212 °F

Media Compatibility

- Mineral oils, other fluids on request

Options and Accessories



Filter Elements

- For use with SF-67 and SFC-57/58 series elements
- For element types with seal contour type A and B
- For element types and flow characteristics see page 176 for SF67 and page 174 for SFC-57/58
- The element is not part of the scope of delivery

Valve

- Bypass valve (integrated in the head): Optional

Clogging Indicators

- For clogging indicator types see page 177

Order Code

SSF - 24B - B1.7 - 4

①

②

③

④

① Type

 Double Spin-On Filter Head **SSF**

② Connection Style

Connection	Thread	Code
BSP	1-1/2	24B

③ Bypass Options

No bypass	0
0,2 bar / 3 PSI	B0.2
1,7 bar / 25 PSI	B1.7

Note: Other settings available on request.

④ Clogging Indicator Port Options

All clogging indicator ports drilled	4
Special	9

Note: Standard clogging indicator port is G1/8.

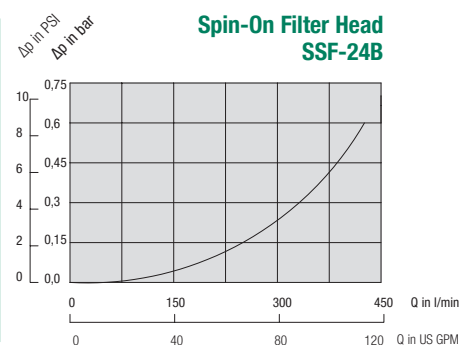

Double Spin-On Filter Heads ■ SSF-24N / 24S

Dimensions



Technical Data

Construction

- In-line Double Spin-On filter head

Material

- Aluminium

Port Connections

- NPT
- SAE flange
- SAE O-ring thread

Flow Rate

- 454 l/min / 120 US GPM for Return-Line application
- 132 l/min / 35 US GPM for Suction-Line application

Operating Pressure

- Max. 12 bar / 174 PSI
- Max. 5 bar / 72.5 PSI differential pressure (for any applicaton without bypass valve)

Temperature Range

- -30 °C ... +100 °C / -22 °F ... +212 °F

Media Compatibility

- Mineral oils, other fluids on request

Options and Accessories



Filter Elements

- For use with SF-67 and SFC-57/58 series elements
- For element types with seal contour type A and B
- For element types and flow characteristics see page 176 for SF-67 and page 174 for SFC-57/58
- The element is not part of the scope of delivery

Valve

- Bypass valve (integrated in the head): Optional

Clogging Indicators

- For clogging indicator types see page 177

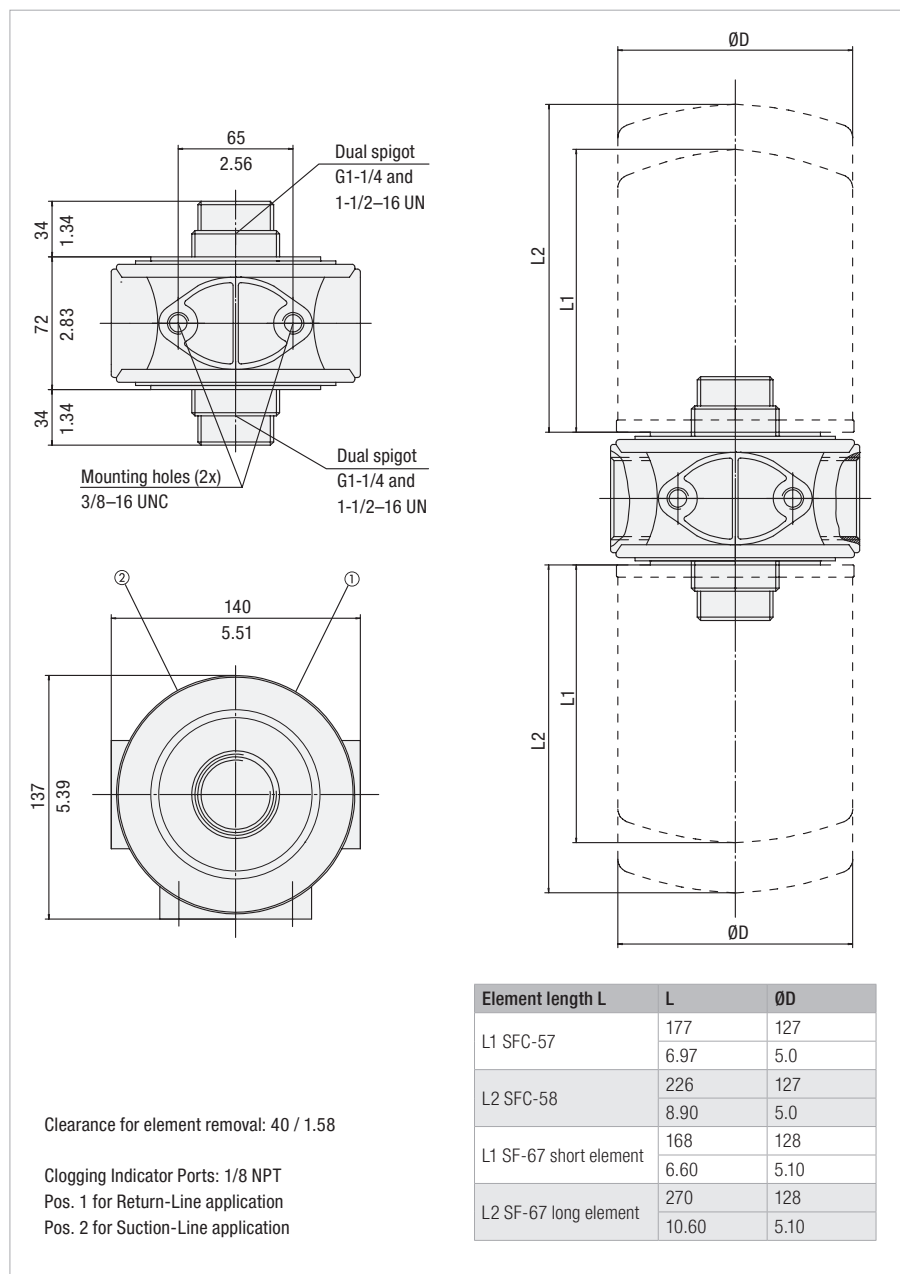
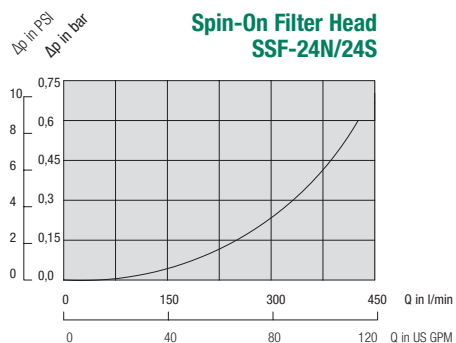

Dimensions in mm / in

Order Code

SSF - 24N - B1.7 - 0

① ② ③ ④

① Type

Double Spin-On Filter Head **SSF**

② Connection Style

Connection	Thread	Code
NPT	1-1/2	24N
SAE	1-7/8-12	24S

③ Bypass Options

No bypass	0
0,2 bar / 3 PSI	B0.2
0,35 bar / 5 PSI	B0.35
1 bar / 15 PSI	B1.0
1,7 bar / 25 PSI	B1.7

④ Clogging Indicator Port Options

No clogging indicator port	0
Clogging indicator port drilled for Return-Line application	1
Clogging indicator port drilled for Suction-Line application	2
All clogging indicator ports drilled	4
Special	9

Note: Standard clogging indicator port is 1/8 NPT.

Double Spin-On Filter Heads ■ SSF-25B

Dimensions

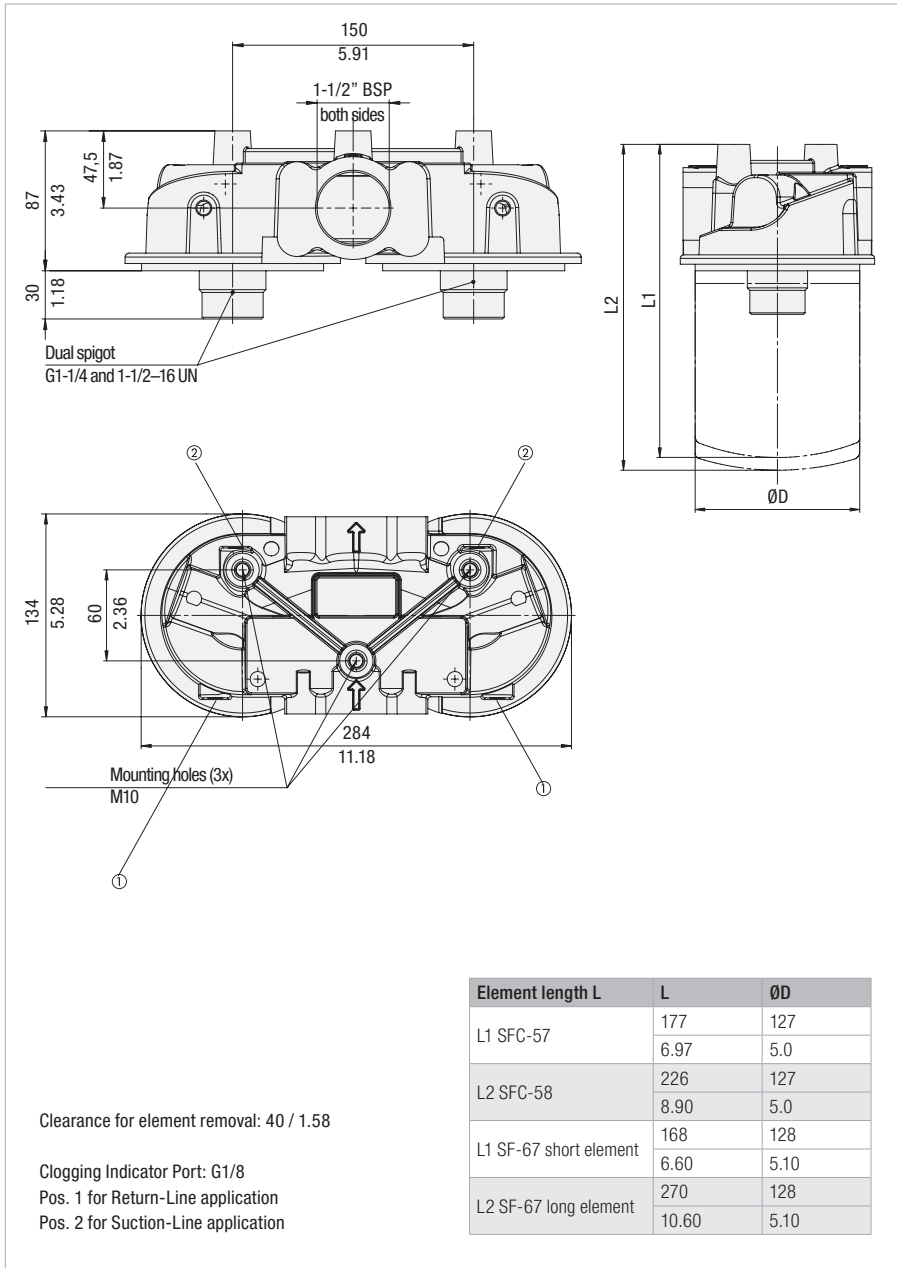

Dimensions in mm / in



Technical Data

Construction

- In-line Double Spin-On filter head

Material

- Aluminium

Port Connections

- BSP

Flow Rate

- 454 l/min / 120 US GPM for Return-Line application
- 132 l/min / 35 US GPM for Suction-Line application

Operating Pressure

- Max. 12 bar / 174 PSI
- Max. 5 bar / 72.5 PSI differential pressure (for any application without bypass valve)

Temperature Range

- -30 °C ... +100 °C / -22 °F ... +212 °F

Media Compatibility

- Mineral oils, other fluids on request

Options and Accessories



Filter Elements

- For use with SF-67 and SFC-57/58 series elements
- For element types with seal contour type A and B
- For element types and flow characteristics see page 176 for SF-67 and page 174 for SFC-57/58
- The element is not part of the scope of delivery

Valve

- Bypass valve (integrated in the head): Optional

Clogging Indicators

- For clogging indicator types see page 177

Order Code

SSF - **25B** - **B1.7** - **4** / **X**

① ② ③ ④ ⑤

① Type

 Double Spin-On Filter Head **SSF**

② Connection Style

Connection	Thread	Code
BSP	1-1/2	25B

③ Bypass Options

No bypass	0
0,2 bar / 3 PSI	B0.2
1,7 bar / 25 PSI	B1.7

Note: Other settings available on request.

④ Clogging Indicator Port Options

All clogging indicator ports drilled	4
Special	9

Note: Standard clogging indicator port is G1/8.

⑤ Design Code

Only for information	X
----------------------	----------

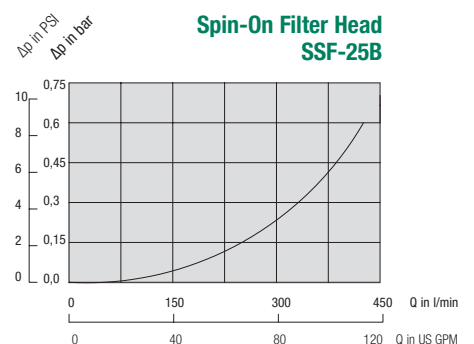

Double Spin-On Filter Heads ■ SSF-25FM

Dimensions



Technical Data

Construction

- In-line Double Spin-On filter head

Material

- Aluminium

Port Connections

- SAE flange

Flow Rate

- 454 l/min / 120 US GPM for Return-Line application
- 132 l/min / 35 US GPM for Suction-Line application

Operating Pressure

- Max. 12 bar / 174 PSI
- Max. 5 bar / 72.5 PSI differential pressure (for any applicaton without bypass valve)

Temperature Range

- -30 °C ... +100 °C / -22 °F ... +212 °F

Media Compatibility

- Mineral oils, other fluids on request

Options and Accessories



- For use with SF-67 and SFC-57/58 series elements
- For element types with seal contour type A and B
- For element types and flow characteristics see page 176 for SF-67 and page 174 for SFC-57/58
- The element is not part of the scope of delivery

Valve

- Bypass valve (integrated in the head): Optional

Clogging Indicators

- For clogging indicator types see page 177

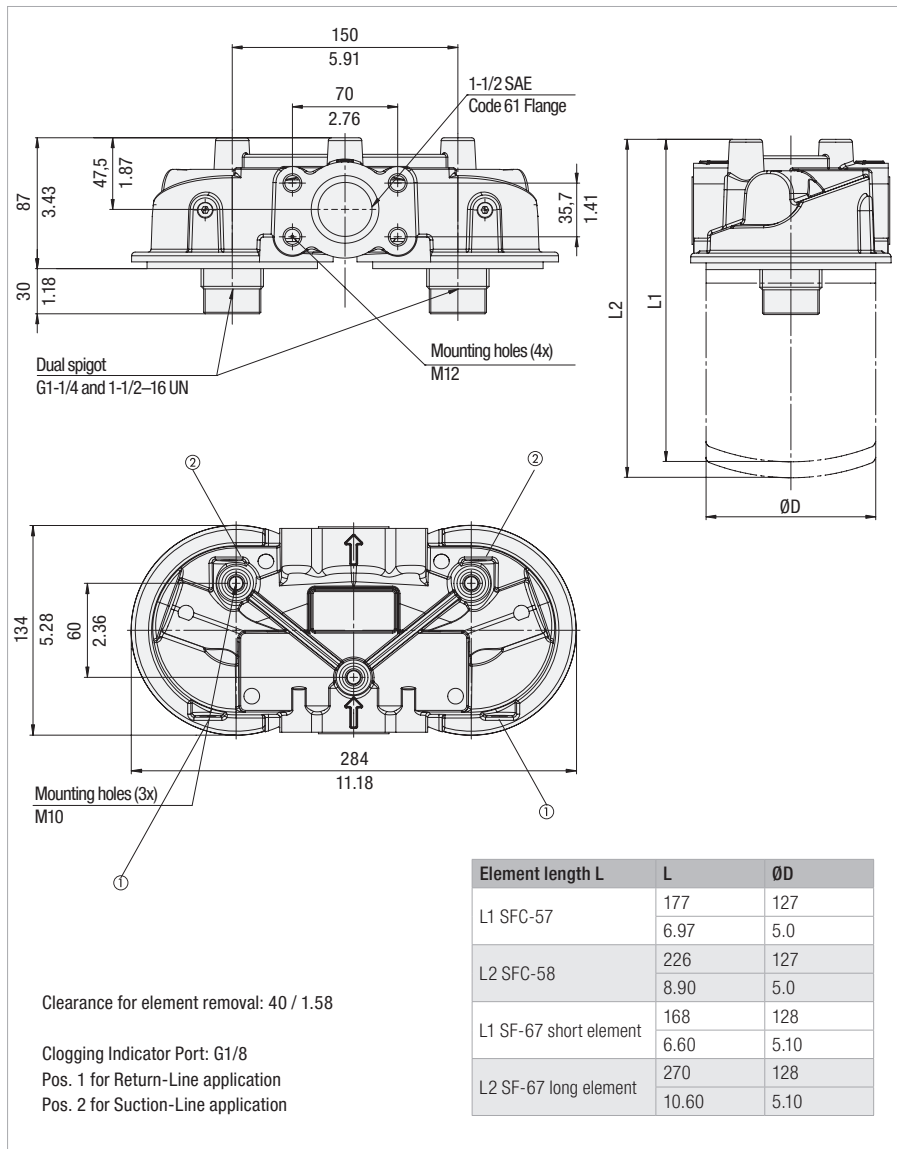

Dimensions in mm / in

Order Code

SSF - 25FM - B1.7 - 4

① ② ③ ④

① Type

Double Spin-On Filter Head	SSF
----------------------------	------------

② Connection Style

Connection	Thread	Code
SAE Flange	1-1/2 SAE Code 61 Flange	25FM

③ Bypass Options

No bypass	0
0,2 bar / 3 PSI	B0.2
1,7 bar / 25 PSI	B1.7

Note: Other settings available on request.

④ Clogging Indicator Port Options

All clogging indicator ports drilled	4
Special	9

Note: Standard clogging indicator port is G1/8.

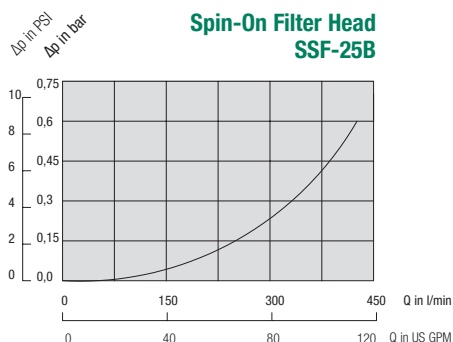

Double Spin-On Filter Heads ■ SSF-25

Dimensions

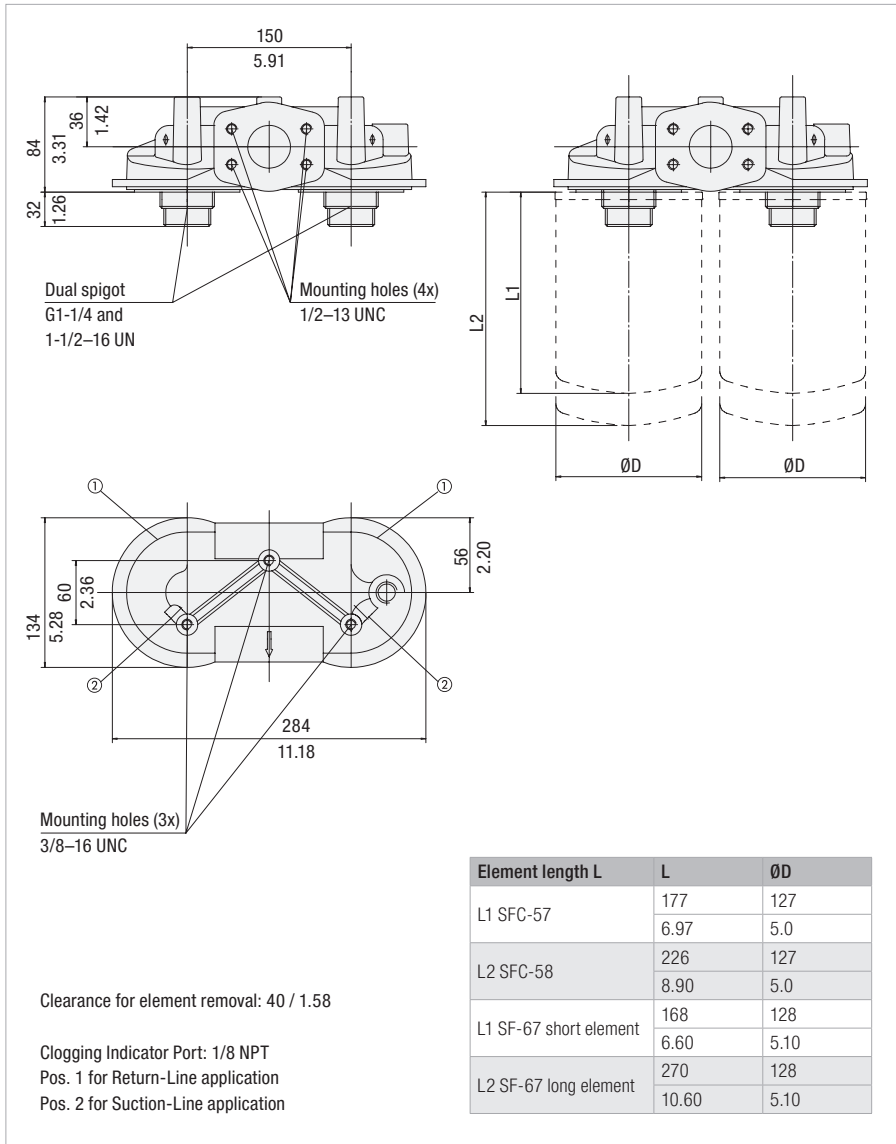

Dimensions in mm / in



Technical Data

Construction

- In-line Double Spin-On filter head

Material

- Aluminium

Port Connections

- NPT
- SAE flange

Flow Rate

- 454 l/min / 120 US GPM for Return-Line application
- 132 l/min / 35 US GPM for Suction-Line application

Operating Pressure

- Max. 12 bar / 174 PSI
- Max. 5 bar / 72.5 PSI differential pressure (for any application without bypass valve)

Temperature Range

- 30 °C ... +100 °C / -22 °F ... +212 °F

Media Compatibility

- Mineral oils, other fluids on request

Options and Accessories



Filter Elements

- For use with SF-67 and SFC-57/58 series elements
- For element types with seal contour type A and B
- For element types and flow characteristics see page 176 for SF-67 and page 174 for SFC-57/58
- The element is not part of the scope of delivery

Valve

- Bypass valve (integrated in the head): Optional

Clogging Indicators

- For clogging indicator types see page 177

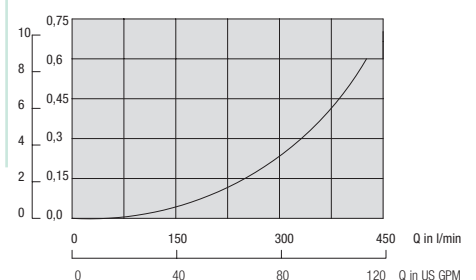
 Spin-On Filter Head
SSF-25

Order Code

SSF - **25** - **B1.7** - **0**

① ② ③ ④

① Type

Double Spin-On Filter Head **SSF**

② Connection Style

Connection	Thread	Code
NPT and SAE Flange	1-1/2 and 2 SAE Code 61 Flange	25

③ Bypass Options

No bypass	0
0,2 bar / 3 PSI	B0.2
0,35 bar / 5 PSI	B0.35
1 bar / 15 PSI	B1.0
1,7 bar / 25 PSI	B1.7

④ Clogging Indicator Port Options

No clogging indicator port	0
Clogging indicator port drilled for Return-Line application	1
Clogging indicator port drilled for Suction-Line application	2
All clogging indicator ports drilled	4
Special	9

Note: Standard clogging indicator port is 1/8 NPT.

Tank Top Spin-On Filter Heads ■ SSFT-12B

Dimensions



Technical Data

Construction

- Tank Top Spin-On filter head

Material

- Aluminium

Port Connections

- BSP

Flow Rate

- 75 l/min / 20 US GPM

Operating Pressure

- Max. 7 bar / 100 PSI

Temperature Range

- -30 °C ... +100 °C / -22 °F ... +212 °F

Media Compatibility

- Mineral oils, other fluids on request

Options and Accessories



Filter Elements

- For use with SFCT-35/36 series elements
- For element types with seal contour type A and B
- For element types and flow characteristics see 174
- The element is not part of the scope of delivery

Valve

- Bypass valve 1,7 bar / 25 PSI integrated in the filter element

Clogging Indicators

- For clogging indicator types see page 177

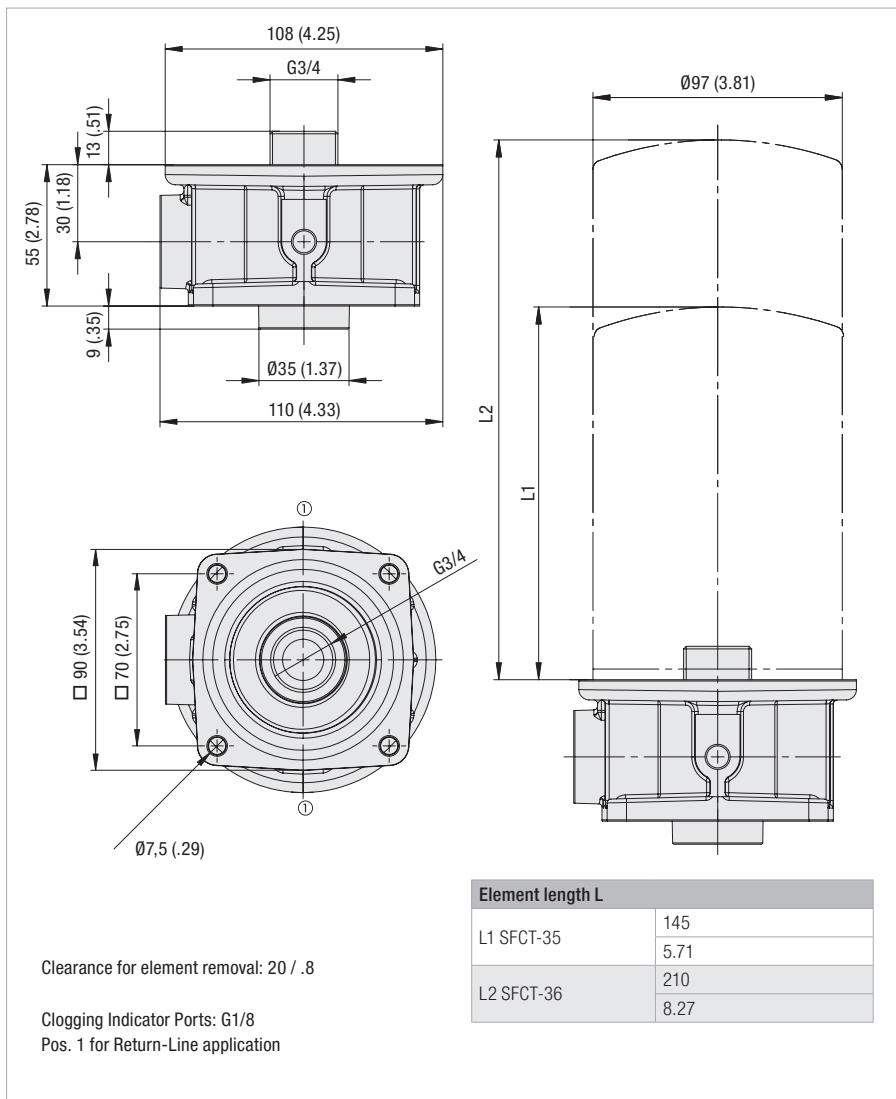

Dimensions in mm / in

Order Code

SSFT - 12B - 1

① ② ③

① Type

Spin-On Filter Head **SSFT**

② Connection Style

Connection	Thread	Code
BSP	3/4	12B

③ Clogging Indicator Port Options

Clogging indicator port drilled for Return-Line application	1
Special	9

Note: Standard clogging indicator port is G1/8.

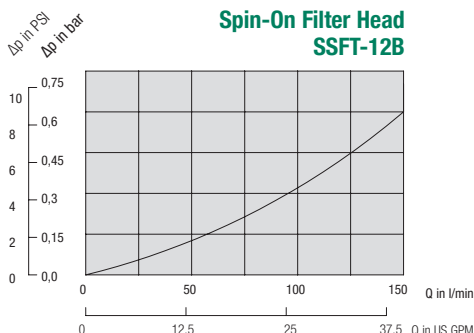

Tank Top Spin-On Filter Heads ■ SSFT-12

Dimensions

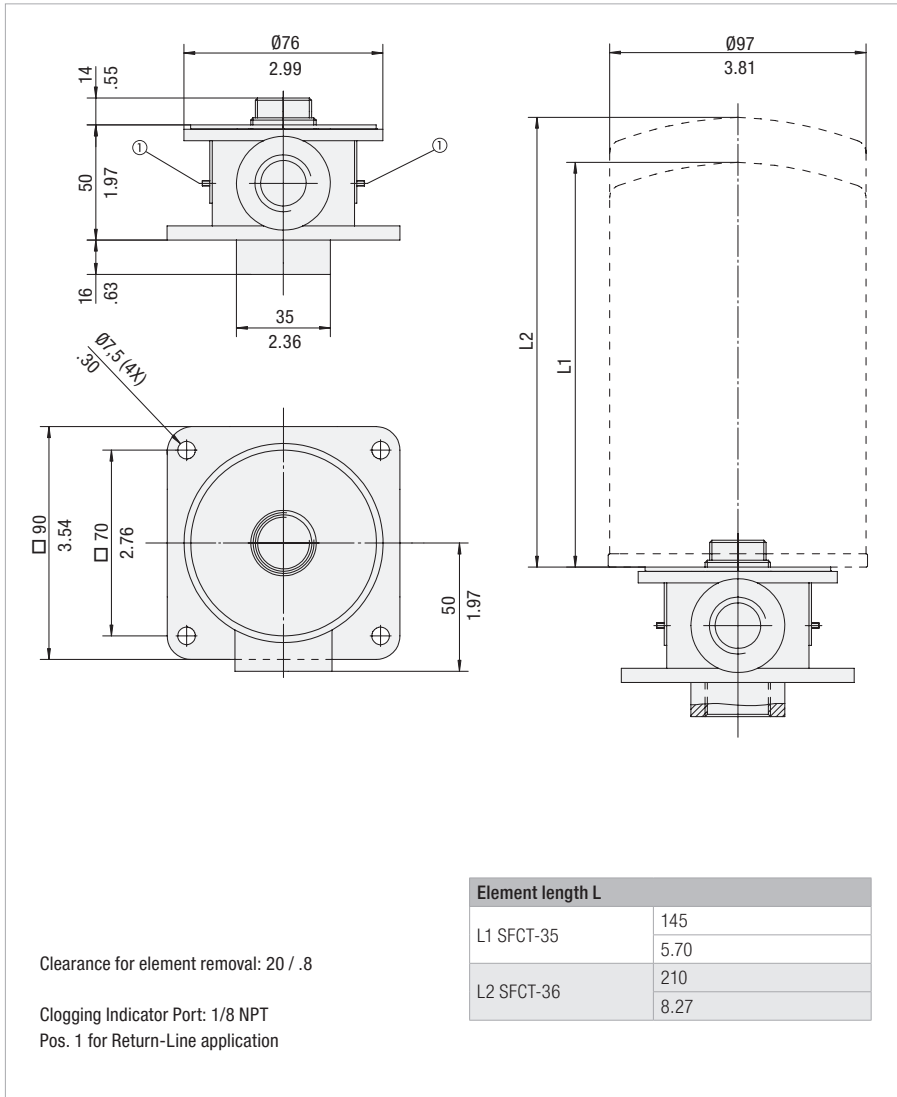

Dimensions in mm / in



Technical Data

Construction

- Tank Top Spin-On filter head

Material

- Aluminium

Port Connections

- NPT

Flow Rate

- 75 l/min / 20 US GPM

Operating Pressure

- Max. 7 bar / 100 PSI

Temperature Range

- -30 °C ... +100 °C / -22 °F ... +212 °F

Media Compatibility

- Mineral oils, other fluids on request

Options and Accessories

Filter Elements

- For use with SFCT-35/36 series elements
- For element types with seal contour type A and B
- For element types and flow characteristics see page 174
- The element is not part of the scope of delivery

Valve

- Bypass valve 1,7 bar / 25 PSI integrated in the filter element

Clogging Indicators

- For clogging indicator types see page 177

Order Code

SSFT - 12 - 1
1
 2
 3

1 Type

Spin-On Filter Head	SSFT
---------------------	-------------

2 Connection Style

Connection	Thread	Code
NPT	3/4	12

3 Clogging Indicator Port Options

No clogging indicator port	0
Clogging indicator port drilled for Return-Line application	1
Special	9

Note: Standard clogging indicator port is 1/8 NPT.

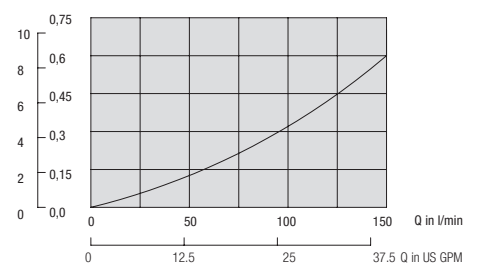
Spin-On Filter Head SSFT-12

Tank Top Spin-On Filter Heads - SSFT-20B

Dimensions

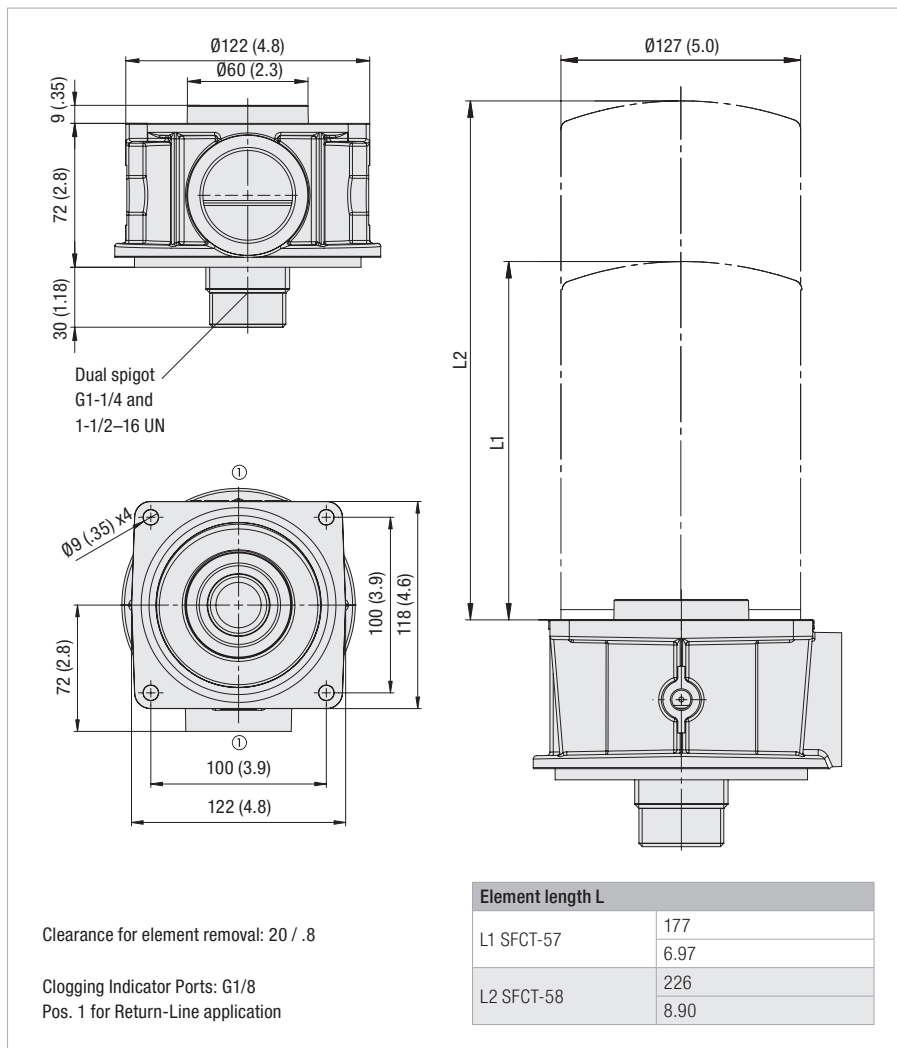

Dimensions in mm / in

Technical Data

Construction

- Tank Top Spin-On filter head

Material

- Aluminium

Port Connections

- BSP

Flow Rate

- 200 l/min / 53 US GPM

Operating Pressure

- Max. 7 bar / 100 PSI

Temperature Range

- 30 °C ... +100 °C / -22 °F ... +212 °F

Media Compatibility

- Mineral oils, other fluids on request

Options and Accessories



Filter Elements

- For use with SFCT-57/58 series elements
- For element types with seal contour type A
- For element types and flow characteristics see page 174
- The element is not part of the scope of delivery

Valve

- Bypass valve 1,7 bar / 25 PSI integrated in the filter element

Clogging Indicators

- For clogging indicator types see page 177

Order Code

SSFT - 20B - 1

①

②

③

① Type

Spin-On Filter Head **SSFT**

② Connection Style

Connection	Thread	Code
BSP	1-1/2	20B

③ Clogging Indicator Port Options

Clogging indicator port drilled for Return-Line application	1
Special	9

Note: Standard clogging indicator port is G1/8.

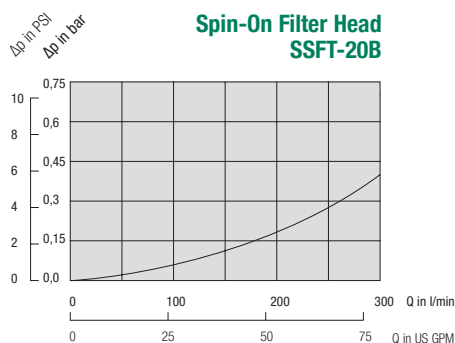

Tank Top Spin-On Filter Heads ■ SSFT-20

Dimensions

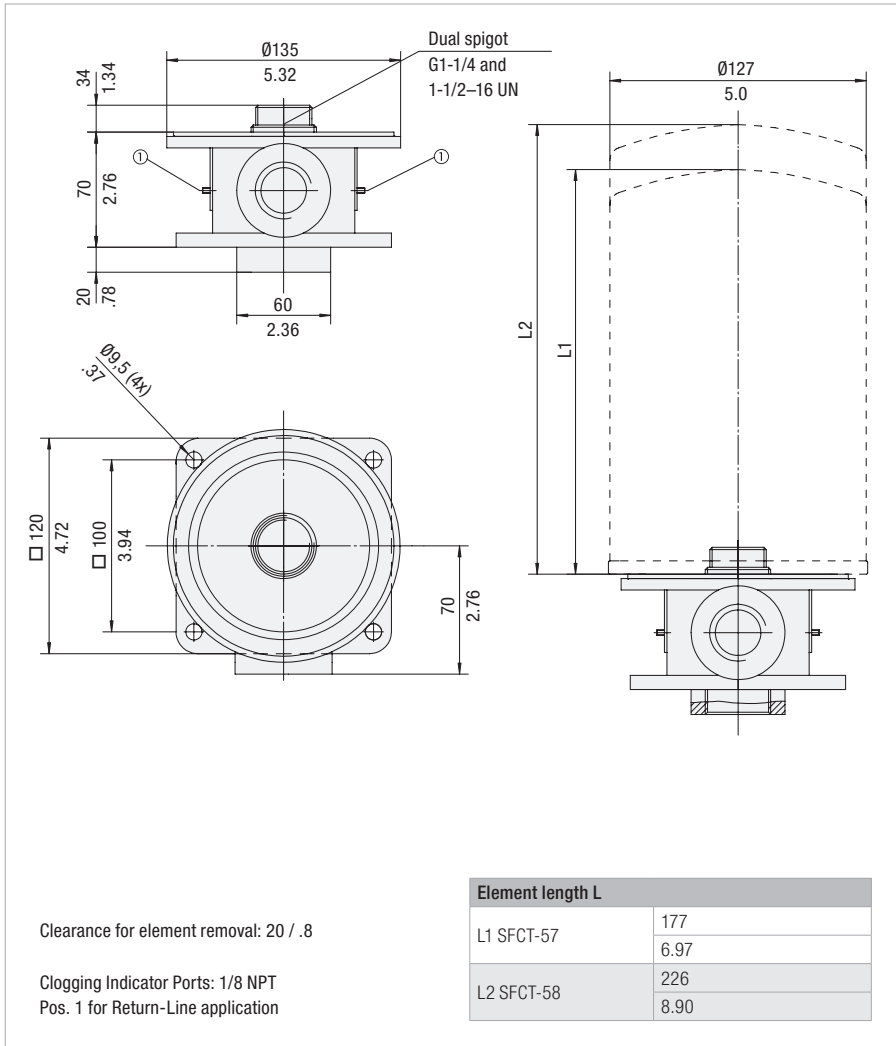

Dimensions in mm / in



Technical Data

Construction

- Tank Top Spin-On filter head

Material

- Aluminium

Port Connections

- NPT

Flow Rate

- 200 l/min / 53 US GPM

Operating Pressure

- Max. 7 bar / 100 PSI

Temperature Range

- -30 °C ... +100 °C / -22 °F ... +212 °F

Media Compatibility

- Mineral oils, other fluids on request

Options and Accessories



Filter Elements

- For use with SFCT-57/58 series elements
- For element types with seal contour type A
- For element types and flow characteristics see page 174
- The element is not part of the scope of delivery

Valve

- Bypass valve 1,7 bar / 25 PSI integrated in the filter element

Clogging Indicators

- For clogging indicator types see page 177

Order Code

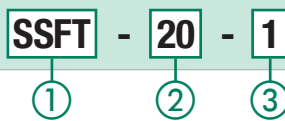

① Type

Spin-On Filter Head **SSFT**

② Connection Style

Connection	Thread	Code
NPT	1-1/2	20

③ Clogging Indicator Port Options

No clogging indicator port	0
Clogging indicator port drilled for Return-Line application	1
Special	9

Note: Standard clogging indicator port is 1/8 NPT.

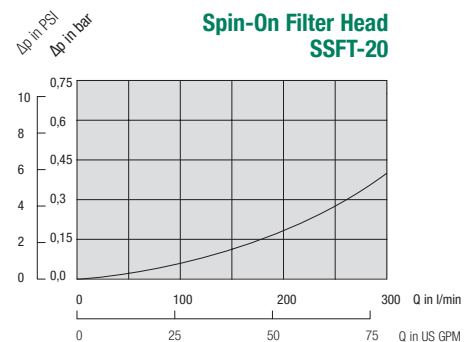

Spin-On Filter Elements

Description

STAUFF offers a wide range of Spin-On filter heads and Spin-On filter elements.

Sealing Material

- NBR (Buna-N®)

Media Compatibility

- Mineral oils, other fluids on request

Temperature Range

- -30 °C ... +100 °C / -22 °F ... +212 °F

Filter Materials

- Wire Mesh, Brass Mesh, Filter Paper, Inorganic Glass Fibre, Stainless Mesh and Water Absorbing Filter Material

Options and Accessories

Valves

- Filter elements type SFCT have an internal bypass and anti-drain back diaphragm

F



Types SFC-35/36, SFCT-35/36

- Use with Spin-On filter heads SSF-12, SSFT-12 and SSFT-12B
- Connection thread: G3/4
- Operating pressure: SFC: max. 12 bar / 174 PSI
SFCT: max 7 bar / 100 PSI
- Differential Pressure: SFC: max. 4 bar / 58 PSI
SFCT: max. 3 bar / 43,5 PSI
- Burst Pressure: SFC: min. 25 bar / 363 PSI
SFCT: min 21 bar / 305 PSI



Types SFC-57/58, SFCT-57/58

- Use with Spin-On filter heads SSF-20L/100/120/120L/130/160 SSF-24B/24N/24S/25B/25FM/25 and SSFT-20B/20
- Connection thread: G1-1/4
- Operating pressure: SFC: max. 12 bar / 174 PSI
SFCT: max 7 bar / 100 PSI
- Differential Pressure: SFC: max. 4 bar / 58 PSI
SFCT: max. 3 bar / 43,5 PSI
- Burst Pressure: SFC: min. 25 bar / 363 PSI
SFCT: min 21 bar / 305 PSI



Type SF-63

- Use with Spin-On filter head SLF
- Connection thread: 3/4–16 UNF
- Operating pressure: max. 14 bar / 200 PSI
- Differential Pressure: max. 5,5 bar / 80 PSI
- Burst Pressure: min. 20 bar / 290 PSI



Type SF-65

- Use with Spin-On filter head SAF
- Connection thread: 1–12 UNF
- Operating pressure: max. 14 bar / 200 PSI
- Differential Pressure: max. 5,5 bar / 80 PSI
- Burst Pressure: min. 20 bar / 290 PSI



Type SF-67

- Use with Spin-On filter heads SSF-20L/100/120/120L/130/150/160/180 SSF-24B/24N/24S/25B/25FM/25
- Connection thread: 1/2–16 UN
- Operating pressure: max. 14 bar / 200 PSI
- Differential Pressure: max. 5,5 bar / 80 PSI
- Burst Pressure: min. 20 bar / 290 PSI



Private Labelling

- On request, the filter elements can be printed with a private label

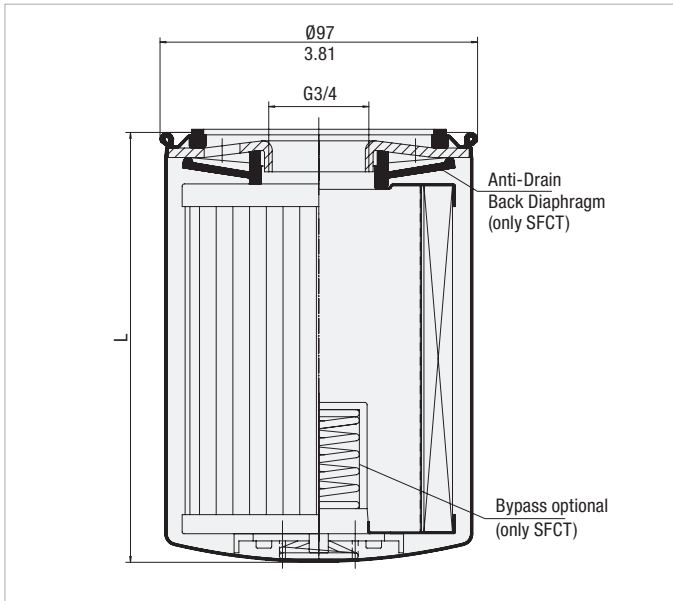
Spin-On Filter Elements ▪ Type SFC-35 / 36 and SFCT-35 / 36

Dimensions in mm / in

Product Description

STAUFF SFC-35/36 series Spin-On Elements are used with the STAUFF SSF-12 Spin-On Filters with G3/4 threaded ports.

STAUFF SFCT-35/36 series Spin-On Elements have an internal 1,7 bar / 25 PSI bypass and anti-drain back diaphragm for use with STAUFF SSFT-12 and SSFT-12B Tank Top Spin-On Filters.

Technical Data
Connection Thread

- G3/4

Seal Contour

- Type A (see page 151)

Sealing Material

- NBR (Buna-N®)

Operating Pressure

- Max. 12 bar / 174 PSI

Differential Pressure

- Paper: Max. 5 bar / 72.5 PSI
Glass Fibre / Wire Mesh: Max. 10 bar / 145 PSI
(for any application without bypass valve)

Burst Pressure

- Min. 20 bar / 290 PSI

Bypass Pressure

- 1,7 bar / 25 PSI (only SFCT-series)

Temperature Range

- -30 °C ... +100 °C / -22 °F ... +212 °F

Media Compatibility

- Mineral oils, other fluids on request

Dimensions

Order Code	Filter Paper				Inorganic Glass Fibre					
	SFC-3510-E	SFC-3610-E	SFC-3525-E	SFC-3625-E	SFC-3503-AE	SFC-3603-AE	SFC-3510-AE	SFC-3610-AE	SFC-3525-AE	SFC-3625-AE
Element without bypass valve										
Element with bypass valve	SFCT-3510-E	SFCT-3610-E	SFCT-3525-E	SFCT-3625-E			SFCT-3510-AE	SFCT-3610-AE	SFCT-3525-AE	SFCT-3625-AE
Length L (mm/in)	145 5.7	210 8.27	145 5.7	210 8.27	145 5.7	210 8.27	145 5.7	210 8.27	145 5.7	210 8.27
β-Ratio	$\beta_{10} \geq 2$	$\beta_{10} \geq 2$	$\beta_{25} \geq 2$	$\beta_{25} \geq 2$	$\beta_3 \geq 200$	$\beta_3 \geq 200$	$\beta_{10} \geq 200$	$\beta_{10} \geq 200$	$\beta_{25} \geq 200$	$\beta_{25} \geq 200$
Carton Quantity	1	1	1	1	1	1	1	1	1	1
Carton Weight (kg/lbs)	0,9 2	1,3 2,6	0,9 2	1,3 2,6	0,9 2	1,3 2,6	0,9 2	1,3 2,6	0,9 2	1,3 2,6

Order Code	Wire Mesh		Brass Mesh	
	SFC-3560-E	SFC-3660-E	SFC-35125-E	SFC-36125-E
Element without bypass valve				
Element with bypass valve	-	-	-	-
Length L (mm/in)	145 5.7	210 8.27	145 5.7	210 8.27
β-Ratio	n/a	n/a	n/a	n/a
Carton Quantity	1	1	1	1
Carton Weight (kg/lbs)	0,9 2	1,3 2,6	0,9 2	1,3 2,6

Spin-On Elements ▪ Type SFC-57 / 58 and SFCT-57 / 58



Product Description

STAUFF Spin-On Filter Elements of the SFC-/SFCT-57/58 series are used with the STAUFF SSF-20L/100/120/120L/130/160 and SSF-24B/24N/24S/25B/25FM/25 series Spin-On Filters with G1-1/4 threaded ports.

STAUFF SFCT-57/58 series Spin-On Elements have an internal 1,7 bar / 25 PSI bypass and anti-drain back diaphragm for use with STAUFF SSFT-20B/20 Tank Top Spin-On Filters.

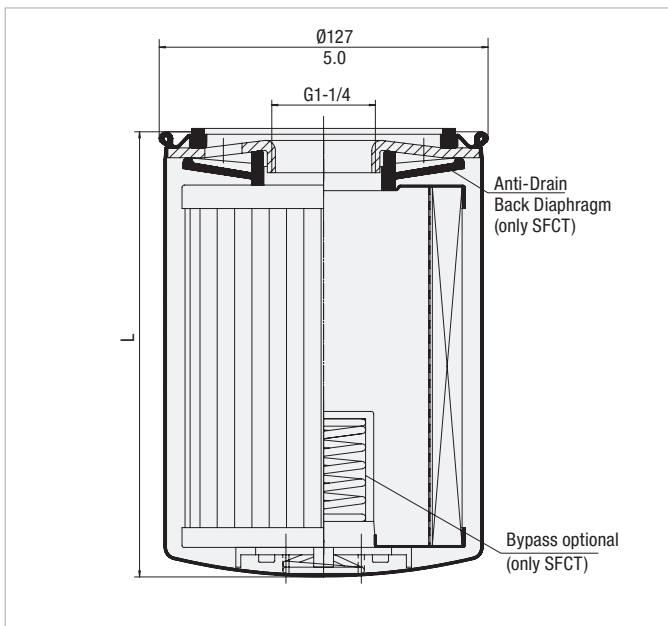

F

Technical Data

Connection Thread

- G1-1/4

Operating Pressure

- Max. 12 bar / 174 PSI

Burst Pressure

- Min. 17 bar / 247 PSI

Temperature Range

- -30 °C ...+100 °C / -22 °F ... +212 °F

Seal Contour

- Type A (see page 151)

Differential Pressure

- Paper: Max. 5 bar / 72.5 PSI
Glass Fibre / Wire Mesh:
Max. 10 bar / 145 PSI
(for any application without bypass valve)

Bypass Pressure

- 1,7 bar / 25 PSI
(only SFCT-series)

Media Compatibility

- Mineral oils, other fluids on request

Sealing Material

- NBR (Buna-N®)

Dimensions

Order Code	Filter Paper				Inorganic Glass Fibre					
	SFC-5710-E	SFC-5810-E	SFC-5725-E	SFC-5825-E	SFC-5703-AE	SFC-5803-AE	SFC-5710-AE	SFC-5810-AE	SFC-5725-AE	SFC-5825-AE
Element without bypass valve	SFC-5710-E	SFC-5810-E	SFC-5725-E	SFC-5825-E	-	-	SFC-5710-AE	SFC-5810-AE	SFC-5725-AE	SFC-5825-AE
Element with bypass valve	SFCT-5710-E	SFCT-5810-E	SFCT-5725-E	SFCT-5825-E	-	-	SFCT-5710-AE	SFCT-5810-AE	SFCT-5725-AE	SFCT-5825-AE
Length L (mm/in)	177 6.97	226 8.9	177 6.97	226 8.9	177 6.97	226 8.9	177 6.97	226 8.9	177 6.97	226 8.9
β-Ratio	$\beta_{10} \geq 2$	$\beta_{10} \geq 2$	$\beta_{25} \geq 2$	$\beta_{25} \geq 2$	$\beta_3 \geq 200$	$\beta_3 \geq 200$	$\beta_{10} \geq 200$	$\beta_{10} \geq 200$	$\beta_{25} \geq 200$	$\beta_{25} \geq 200$
Carton Quantity	1	1	1	1	1	1	1	1	1	1
Carton Weight (kg/lbs)	1,4 3	1,85 4	1,4 3	1,85 4	1,4 3	1,85 4	1,4 3	1,85 4	1,4 3	1,85 4

Order Code	Wire Mesh		Brass Mesh	
	SFC-5760-E	SFC-5860-E	SFC-57125-E	SFC-58125-E
Element without bypass valve	SFC-5760-E	SFC-5860-E	SFC-57125-E	SFC-58125-E
Element with bypass valve	-	-	-	-
Length L (mm/in)	177 6.97	226 8.9	177 6.97	226 8.9
β-Ratio	n/a	n/a	n/a	n/a
Carton Quantity	1	1	1	1
Carton Weight (kg/lbs)	0,9 2	1,3 2,6	0,9 2	1,3 2,6

Spin-On Elements ▪ Type SF-63

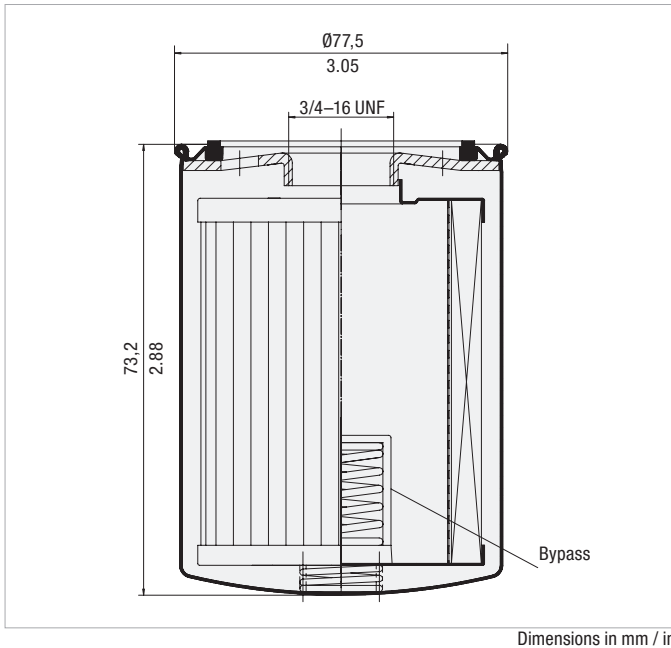

Dimensions in mm / in



Product Description

STAUFF SF-63-series Spin-On Elements are used with the STAUFF SLF Spin-On Filters.

Technical Data

Connection Thread

- 3/4-16 UNF

Seal Contour

- Type A (see page 151)

Sealing Material

- NBR (Buna-N®)

Operating Pressure

- Max. 14 bar / 200 PSI

Differential Pressure

- Max. 5,5 bar / 80 PSI
(for any application without bypass valve)

Burst Pressure

- Min. 20 bar / 290 PSI

Bypass Pressure

- SF-6310-18 1,24 bar / 18 PSI
- SF-6325-10 0,70 bar / 10 PSI

Temperature Range

- -30 °C ... +100 °C / -22 °F ... +212 °F

Media Compatibility

- Mineral oils, other fluids on request

Dimensions

Order Code	Filter Paper	
	SF-6310-18	SF-6325-10
β-Ratio	$\beta_{10} \geq 2$	$\beta_{25} \geq 2$
Dirt Holding Capacity (g)	6	6
Carton Quantity	12	12
Carton Weight (kg/lbs)	3,6	3,6
	8	8

Spin-On Elements ▪ Type SF-65



Product Description

STAUFF SF-65-series Spin-On Elements are used with the STAUFF SAF series Spin-On Filters.

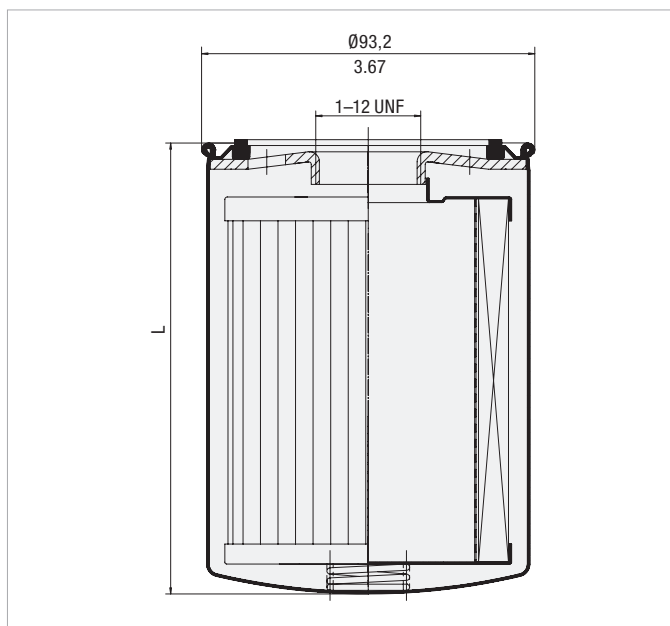

Dimensions in mm / in

Technical Data

Connection Thread

- 1-12 UNF

Seal Contour

- Type A (see page 151)

Sealing Material

- NBR (Buna-N®)

Operating Pressure

- Max. 14 bar / 200 PSI
- SF-6520-W: Max. 7 bar / 101.5 PSI

Differential Pressure

- Max. 5,5 bar / 80 PSI
- (for any application without bypass valve)

Burst Pressure

- Min. 20 bar / 290 PSI







Temperature Range

- -30 °C ... +100 °C / -22 °F ... +212 °F

Media Compatibility

- Mineral oils, other fluids on request

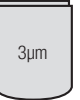
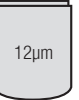
Dimensions

Order Code	Filter Paper				Inorganic Glass Fibre			Water Absorbing
	SF-6520	SF-6521	SF-6510	SF-6511	SF-6549	SF-6505	SF-6504	SF-6520-W
								
Length L (mm/in)	137 5.39	204 8.00	137 5.39	204 8.00	137 5.39	137 5.39	137 5.39	133 5.25
β-Ratio	$\beta_{10} \geq 2$	$\beta_{10} \geq 2$	$\beta_{25} \geq 2$	$\beta_{25} \geq 2$	$\beta_3 \geq 200$	$\beta_{12} \geq 200$	$\beta_{25} \geq 200$	$\beta_{10} \geq 2$
Dirt Holding Capacity ACFTD (g)	14.4	22	20.4	31.2	19	11	26	Water holding capacity 162 ml 5.5 oz
Carton Quantity	12	12	12	12	12	12	12	12
Carton Weight (kg/lbs)	6,3 13.9	8,4 18.5	6,4 14.2	8,8 19.4	8,6 19	8,6 19	8,6 19	8,6 19

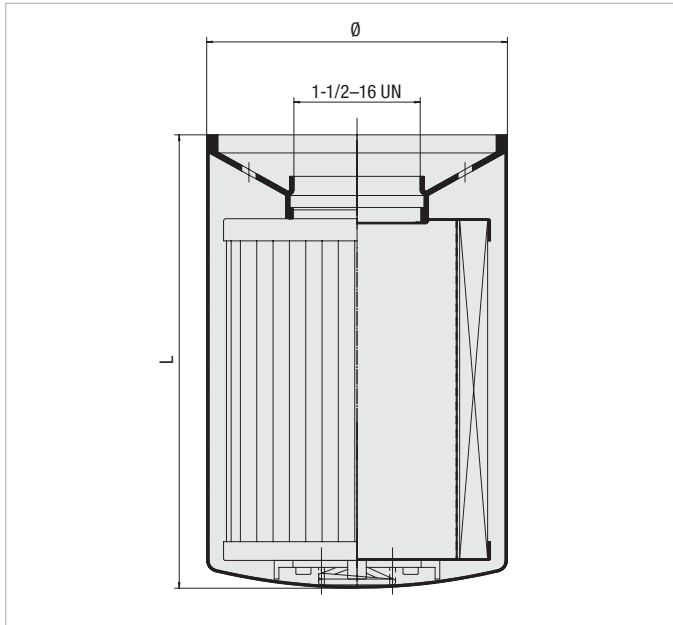
Spin-On Elements ▪ Type SF-67

Dimensions in mm / in

Product Description

STAUFF SF-67-series Spin-On Elements are used with the STAUFF SSF-20L/100/120/120L/130/150/160/180 and SSF-24B/24N/24S/25B/25FM/25 Spin-On Filters.

Technical Data
Connection Thread

- 1-1/2-16 UN

Sealing Material

- NBR (Buna-N®)

Differential Pressure

- Max. 5,5 bar / 80 PSI
(for any application without bypass valve)

Temperature Range

- -30 °C ... +100 °C / -22 °F ... +212 °F

Seal Contour

- Type B (see page 151)

Operating Pressure

- Max. 14 bar / 200 PSI
- SF-6721-W: Max. 7 bar / 101.5 PSI

Burst Pressure

- Min. 20 bar / 290 PSI

Media Compatibility

- Mineral oils, other fluids on request

Dimensions

Order Code	Inorganic Glass Fibre								
	SF-6702-MG	SF-6703-MG	SF-6704-MG	SF-6706-MG	SF-6707-MG	SF-6730-MG	SF-6731-MG	SF-6728-MG	SF-6726-MG
Length L (mm/in)	270 10.6	168 6.6	270 10.6	168 6.6	270 10.6	168 6.6	270 10.6	168 6.6	270 10.6
Diameter Ø (mm/in)	129 5.08	129 5.08	129 5.08	129 5.08	129 5.08	129 5.08	129 5.08	129 5.08	129 5.08
β-Ratio	β ₁ ≥ 200	β ₃ ≥ 200	β ₃ ≥ 200	β ₆ ≥ 200	β ₆ ≥ 200	β ₁₂ ≥ 200	β ₁₂ ≥ 200	β ₂₅ ≥ 200	β ₂₅ ≥ 200
Dirt Holding Capacity ACFTD (g)	30	31	47	35	54	38	59	50	76
Carton Quantity	6	6	6	6	6	6	6	6	6
Carton Weight (kg/lbs)	11,8 26.1	8,2 18	11,8 26.1	8,2 18	11,8 26.1	8,2 18	11,8 26.1	8,2 18	11,8 26.1

Order Code	Filter Paper				Stainless Mesh		Water Absorbing
	SF-6720	SF-6721	SF-6710	SF-6711	SF-6790	SF-6791	SF-6721-W
Length L (mm/in)	168 6.6	270 10.6	168 6.6	270 10.6	168 6.6	270 10.6	270 10.6
Diameter Ø (mm/in)	128,5 5.06	128,5 5.06	128,5 5.06	128,5 5.06	128,5 5.06	128,5 5.06	128,5 5.06
β-Ratio	β ₁₀ ≥ 2	β ₁₀ ≥ 2	β ₂₅ ≥ 2	β ₂₅ ≥ 2	n/a	n/a	β ₁₀ ≥ 2
Dirt Holding Capacity ACFTD (g)	34	62	34	62	n/a	n/a	Water holding capacity 444 ml / 15 oz
Carton Quantity	6	6	6	6	6	6	6
Carton Weight (kg/lbs)	6,6 14.6	7,9 17.5	6,7 14.9	9,3 20.6	8,2 18	11,8 26.1	11,8 26.1

F

Spin-On Elements ■ Type SFC/SFCT-35/36, SFC/SFCT-57/58 and SF-63

The following characteristics are valid for mineral oils with a density of 0,85 kg/dm³ and the kinematic viscosity of 30 mm²/s (30 cSt). The characteristics have been determined in accordance to ISO 3968. SFC-35/36 series Spin-On Elements are used with STAUFF SSF-12 Spin-On Filters, SFCT-35/36 series Spin-On Elements are used with STAUFF SSFT-12 Spin-On Filters, SFC-57/58 series Spin-On Elements are used with STAUFF SSF-20/24/25/100/120/130/160 Spin-On Filters, SFCT-57/58 series Spin-On Elements are used with STAUFF SSFT-20 Spin-On Filters and SF-63 series Spin-On Elements are used with STAUFF SLF-02/03/04 Spin-On Filters.

F

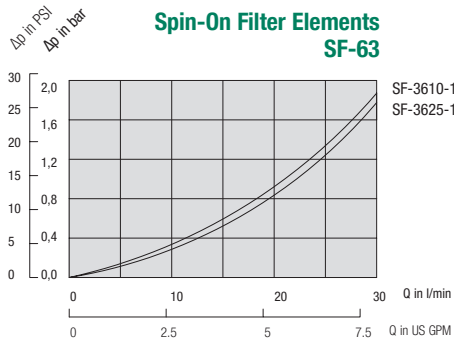
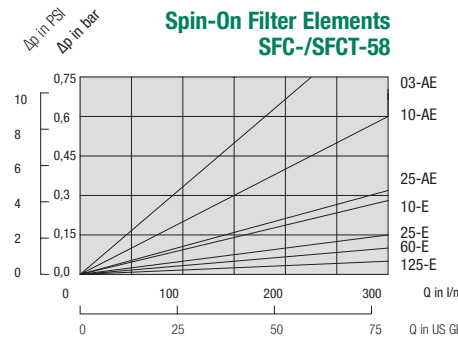
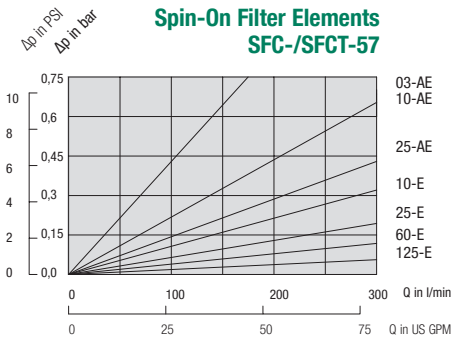
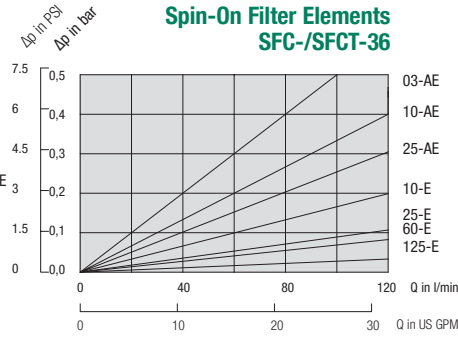
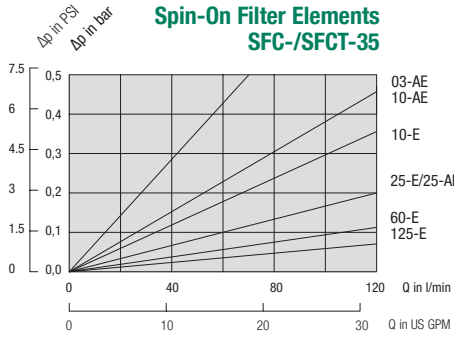

Spin-On Elements ■ Type SF-65

The following characteristics are valid for mineral oils with a density of 0,85 kg/dm³ and the kinematic viscosity of 30 mm²/s (30 cSt).

The characteristics have been determined in accordance to ISO 3968. SF-65 Spin-On Elements are used with the STAUFF SAF-05/06/07/10/11/13 Spin-On Filters.

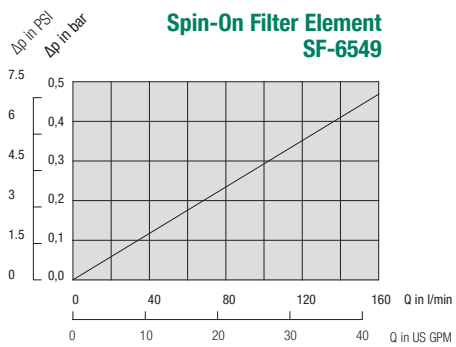
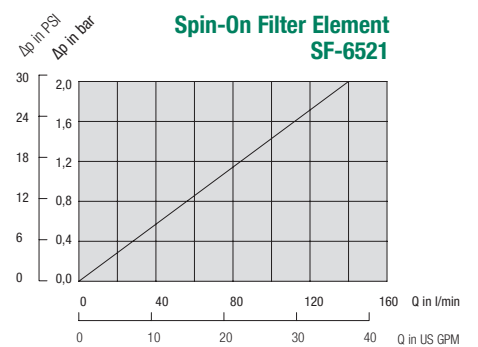
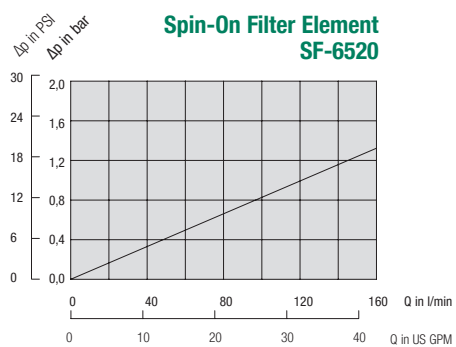
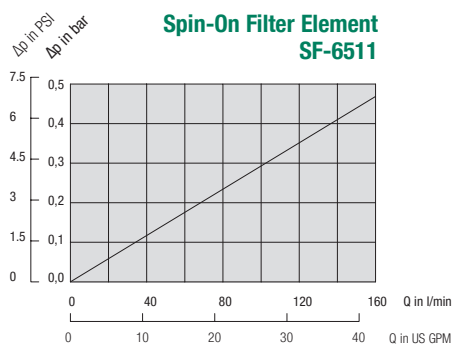
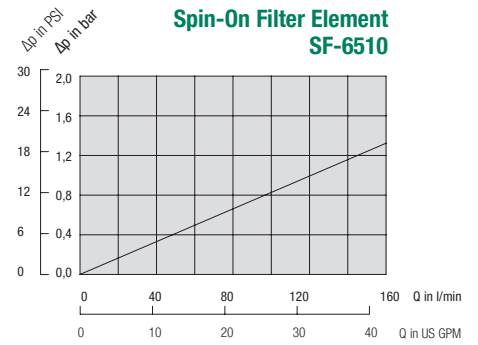
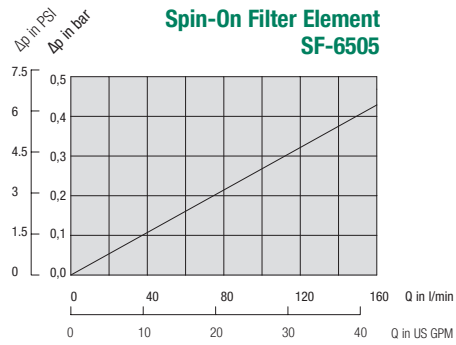
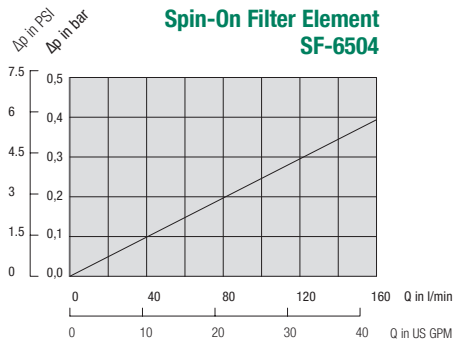

F

Spin-On Elements ▪ Type SF-67

The following characteristics are valid for mineral oils with a density of 0,85 kg/dm³ and the kinematic viscosity of 30 mm²/s (30 cSt).
 The characteristics have been determined in accordance to ISO 3968. SF-67 Spin-On Elements are used with the STAUFF SSF-20/24/25/100/120/130/160/150/180 Spin-On Filters.

F

Spin-On Filter Element SF-6702-MG

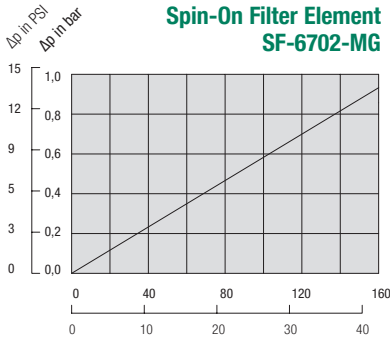

Spin-On Filter Element SF-6703-MG

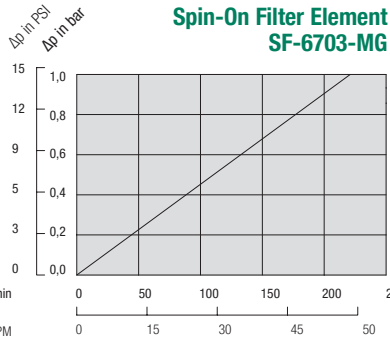

Spin-On Filter Element SF-6704-MG

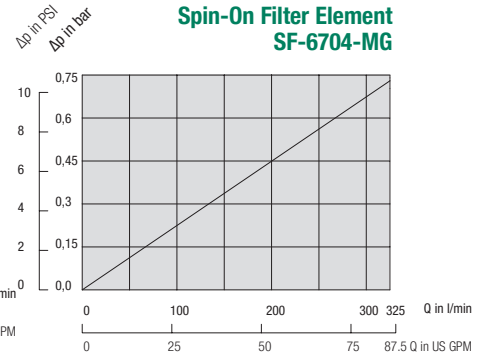

Spin-On Filter Element SF-6706-MG

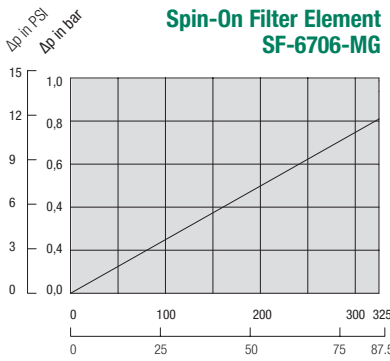

Spin-On Filter Element SF-6707-MG

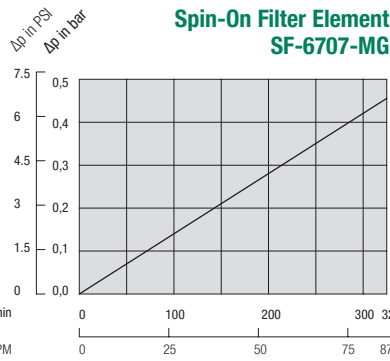

Spin-On Filter Element SF-6710

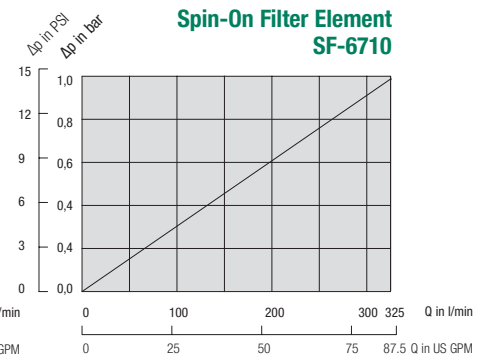

Spin-On Filter Element SF-6711

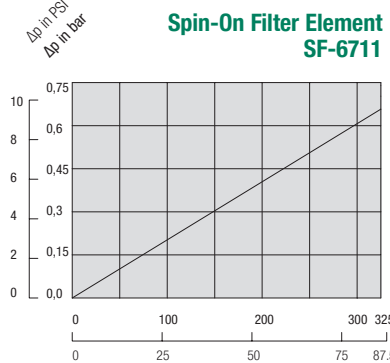

Spin-On Filter Element SF-6720

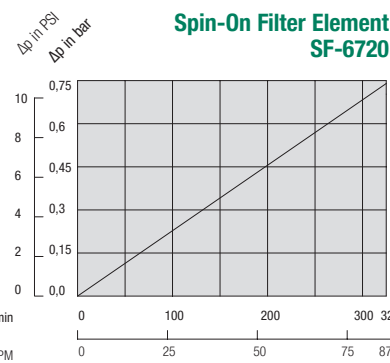

Spin-On Filter Element SF-6721

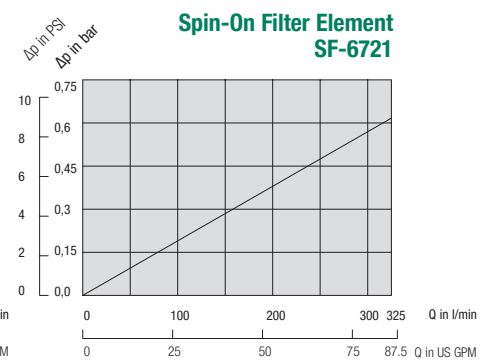

Spin-On Filter Element SF-6726-MG

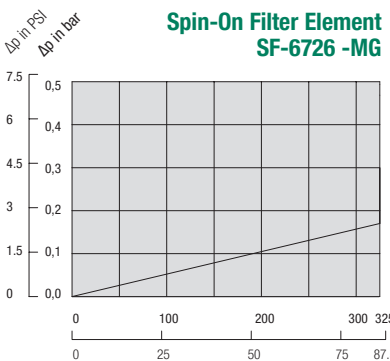

Spin-On Filter Element SF-6728-MG

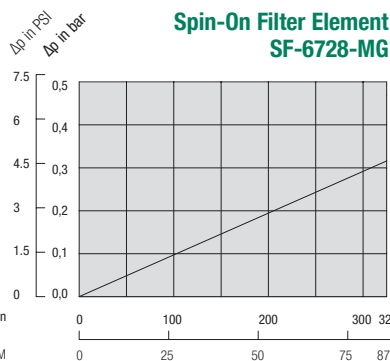

Spin-On Filter Element SF-6730-MG

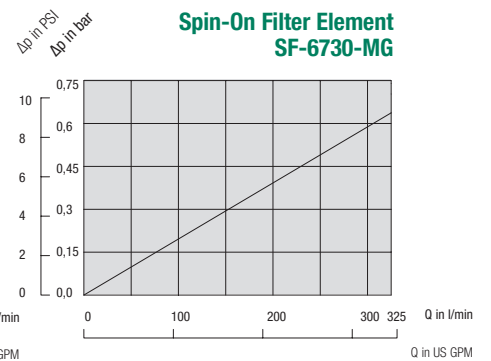

Spin-On Filter Element SF-6731-MG

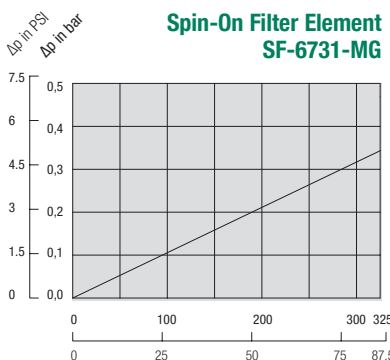

Spin-On Filter Element SF-6790/91

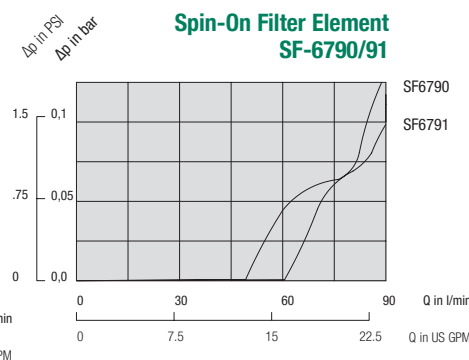

Clogging Indicators

Visual Indicators

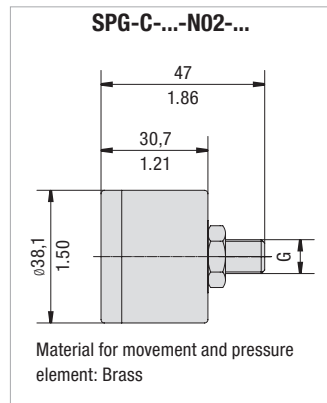
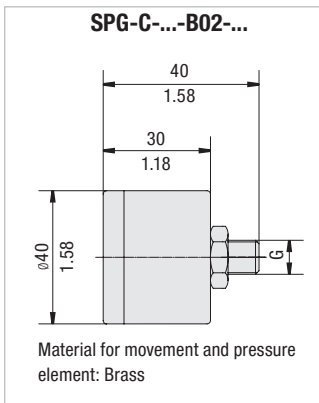

SPG-C-...-B02-...



SPG-C-...-N02-...



SPG-C-...-B02-...



SPG-C-...-N02-...

Visual Pressure Clogging Indicators (for Spin-On Filter in Return-Line applications)							Order Code
Thread	Connection G	Unit of scale	Range of scale	Coloured Segments			
				Green	Yellow	Red	
BSP	1/8	bar	0 ... 2,5	0 ... 1,2	1,2 ... 1,5	1,5 ... 2,5	SPG-C-040-00002.5-02-P-B02-402923
	1/8	bar	0 ... 4	0 ... 2,5	2,5 ... 3	3 ... 4	SPG-C-040-00004-02-P-B02-402922
	1/8	bar	0 ... 12	without coloured segments			SPG-C-040-00012-02-P-B02
NPT	1/8	PSI	0 ... 100	0 ... 13	13 ... 15	15 ... 100	SPG-C-040-00100-03-P-N02-402927
	1/8	PSI	0 ... 100	0 ... 21	21 ... 25	25 ... 100	SPG-C-040-00100-03-P-N02-402928
Visual Vacuum Clogging Indicators (for Spin-On Filter in Suction-Line applications)							Order Code
R	1/8	cm Hg	-76 ... 0	-13 ... 0	-18 ... -13	-76 ... -18	SPG-C-040-(-76)-00000-22-P-T02-402924
NPT	1/8	in Hg	-30 ... 0	-4 ... 0	-6 ... -4	-30 ... -6	SPG-C-040-(-30)-00000-23-P-N02-402925
	1/8	in Hg	-30 ... 0	-9 ... 0	-11 ... -9	-30 ... -11	SPG-C-040-(-30)-00000-23-P-N02-402926

Order Code

Electrical Clogging Switch

Limit-Switch - G42NO - S - B02 - B1.3

①

②

③

④

⑤

① Type

Limit-Switch

② Connector Type

Electrical Clogging Switch 10 V ... 42 V, NO	G42NO
Electrical Clogging Switch 10 V ... 42 V, NC	G42NC
Electrical Clogging Switch 10 V ... 250 V, two-way contact (only for Plug Type W)	G230

③ Plug Type

M12 Five-Pin Connector according to IEC 61076-2-101	M12
AMP-Junior-Timer Plug	A
DEUTSCH Plug DT04-2P	D
Rubber boot	S
90 degree Polyamide cap (only for Connector Type G230)	W

④ Thread Type

1/8 BSP	B02
1/8 NPT	N02

⑤ Pressure Setting

1,3 bar / 18,8 PSI	B1.3
-0,1 bar / -1,45 PSI*	B-0.1

*only for Plug Type W and Connector Type G230



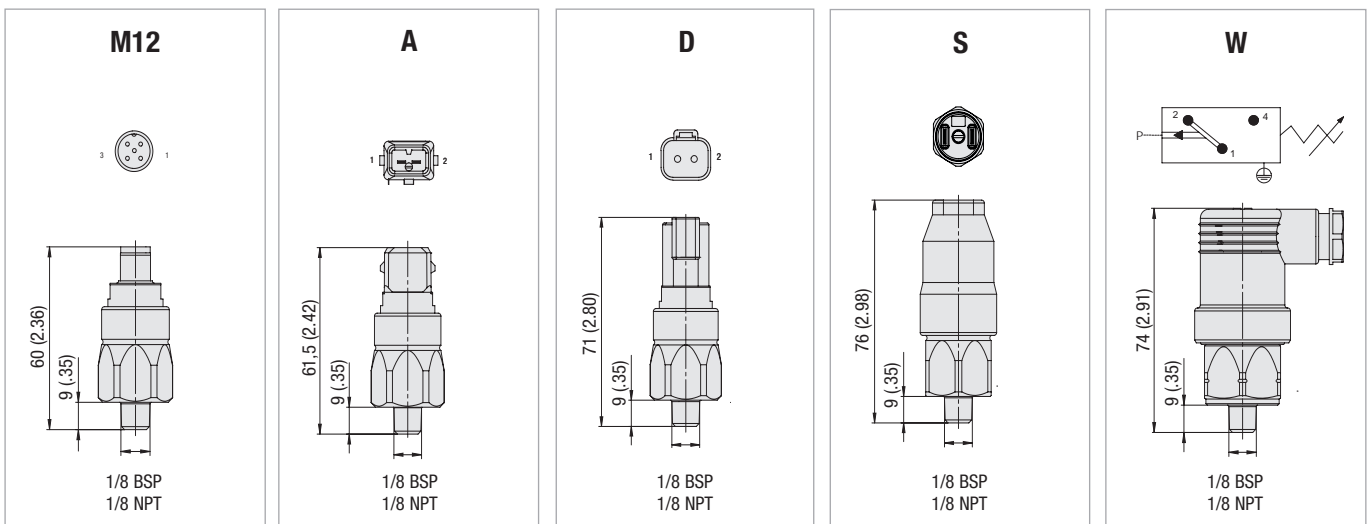

Note: Technical Data for Limit-Switch types please see Page 73.

Dimensions Plug Type



Note: The customer / user carries the responsibility for the electrical connection.

Dimensional drawings: All dimensions in mm/in.

	Overview Offline and Bypass Filters	180		Bypass Filters	BPS	199 - 202
	STAUFF System	181		Overview		199
	Offline and Bypass Filters Replacement Elements	182		Technical Data / Dimensions		200 - 201
	Offline Filters	OLS	183 - 188	Order Code - Bypass Filter		201
	Overview		183	Order Code - Filter Elements		201
	Technical Data / Dimensions		184 - 187	Hydraulic Symbols / Flow Characteristics for OLS / BPS		202
	Order Code - Offline Filter		188			
	Order Code - Filter Elements		188			
	Water Absorbing Offline Filters	OLSW	189 - 194			
	Overview		189			
	Technical Data / Dimensions		190 - 193			
	Order Code - Water Absorbing Offline Filter		194			
	Order Code - Filter Elements		194			
	Order Code - Pre-Filter Elements		194			
	Heated Offline Filters	OLSH	195 - 198			
	Overview		195			
	Technical Data / Dimensions		196 - 197			
	Order Code - Offline Filter		198			
	Order Code - Filter Elements		198			

Product Description

STAUFF Offline and Bypass Filter Systems are designed to keep hydraulic and lubrication systems free of particles and water contamination. STAUFF OLS and BPS Units utilize the STAUFF Systems concept for the removal of contamination from hydraulic and lubrication systems. Desiccant Air Breathers, which clean and dry the air entering the reservoir, are also part of this contamination removal system.

STAUFF Systems will provide optimal system cleanliness for today's sophisticated hydraulic and lubrication systems.

- Increased flow capacity and dirt-hold capacity
- Prevention of channel forming by radial filtration direction
- Extremely clean oil due to the high filtration efficiency $\beta_{0,5} \geq 200$, $\beta_2 \geq 2330$
- Compact and easy-maintenance design
- Longer usage life for oil and components

Material

- Housing: Anodized Aluminium, available with one, two or four filter housings in two different length

Housing Pressure

- Max. 20 bar / 290 PSI

System Volume

- Max. 10800 l / 2853 US GAL

Connections

- G3/8, G1/2 and G3/4, Fitting with 18L connection

Differential Pressure

- Max. 6,2 bar / 90 PSI

Temperature

- Max. +80 °C / +176 °F media temperature

Media Compatibility

- Mineral and lubrication oils, others on request

Options and Accessories

Clogging Indicators

- Visual Clogging Indicators

G



Type OLS

- Offline Filter System with integrated motor/pump unit
- Available Special designed for industrial applications



Type BPS

- Bypass filter units are especially designed for mobile
- Applications in hydraulic and/or transmission systems
- No special motor-pump unit is required



Type OLSW

- Water absorbing filter elements with large water holding capacity



Type OLSH

- Pre-heating unit and extremely efficient filter elements
- Increased flow capacity

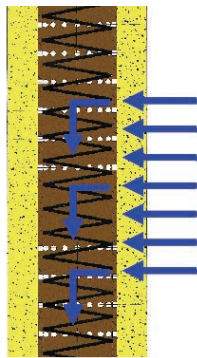
Filter Element SRM-30/-60

Filter Element Design

Air Conditioners SDB / SVDB

System Contamination

In today's hydraulic market it is an accepted fact that contamination causes 70 % of all mechanical failures. This contamination results from the presence of solid particles such as metal, sand and rubber.

Changes in temperature cause water vapour to condense, resulting in unwanted water in the oil, the presence of this water accelerates the deterioration of the oil.

Mainstream filters are incapable of removing particles, smaller than 2 micron (better known as silt). Fluctuations in pressure and flow result in changing conditions preventing these filters from carrying out fine filtration; most of the silt remains in the system affecting the chemical composition of the oil.

All these problems lead to reduced oil life and increased component wear, maintenance costs and machine downtime.

Removing silt and preventing the formation of free water will combat these problems.

Micro Filtration

At the heart of the STAUFF Offline and Bypass Filter Unit is the unique microfilter element. This filter is designed with a radial flow path.

The element is constructed with 0,5 micron media and is therefore able to remove the smallest particles (silt) from the oil.

The filter material is composed primarily of cellulose, which is applied by a special wrapping method. Glass Fibre and water absorbing elements with 3-20 µm are available on request.

The cellulose material is capable of retaining solid particles and absorbing water. This helps to prevent chemical deterioration of the oil and the formation of various acids and sludge.

Hydraulic cylinder extension for example, can draw air, solid contamination particles and water vapour into the oil reservoir.

The water vapour condenses due to temperature changes and causes not only oxidation of the oil, but can also lead to serious mechanical wear in the system.

Air Conditioning

Standard air filters remove a certain amount of solid particle contamination from the air but allow water vapour, to pass through.

The STAUFF "Air conditioners" type SDB and SVDB ensure that incoming air is first dried and then filtered. The SDB and SVDB units should be used in conjunction with the OLS / BPS Systems in order to provide a more complete filtering system. See Catalogue No. 10 - Hydraulic Accessories for more details.

Advantages

- Less malfunction
- Protection of expensive main stream filters
- Less frequent oil changes
- Extended usable life of the oil
- Less machine downtimes

Characteristics

- A filter fineness of 0,5 micron $B_{0,5} \geq 200$, $B_2 \geq 2330$
- Large particle collection capacity
- High filtration capacity due to depth effect
- Large water adsorption capacity
- Do not adversely affect viscosity or additives
- Do not remove additives
- Reduce the oxidation process
- Reduce the forming of acids
- With two measuring points for particle counter or oil sampling
- Save Cost

Applications

- | | |
|---|---|
| <ul style="list-style-type: none"> ▪ Mining ▪ Harvesting ▪ Forestry ▪ Agricultural ▪ Off-road ▪ Fishing ▪ Road construction ▪ Cranes ▪ Airport equipment ▪ Flight simulators ▪ Pulp and paper ▪ Food processing | <ul style="list-style-type: none"> ▪ Presses ▪ Automotive industry ▪ Timber plants ▪ Plastic and rubber ▪ Metal industry ▪ Cement and concrete ▪ Material handling ▪ Bridges/Hydraulic locks/Water works ▪ Petrochemical industry ▪ Power stations ▪ Marine ▪ Steel |
|---|---|

Offline and Bypass Filters Replacement Elements - Type SRM

Filter Element Technical Data

Element Model	SRM-30-H-B	SRM-60-H-B	SRM-30-E-01-B	SRM-60-E-01-B	SRM-30-E-03-B	SRM-60-E-03-B	SRM-30-EA	SRM-60-EA
Filter Material	Cellulose	Cellulose	Glass fibre	Glass fibre	Glass fibre	Glass fibre	Glass fibre and Polymer	Glass fibre and Polymer
Filtration Efficiency	$\beta_2 \geq 2331$	$\beta_2 \geq 2331$	$\beta_1 \geq 200$	$\beta_1 \geq 200$	$\beta_3 \geq 200$	$\beta_3 \geq 200$	$\beta_3 \geq 200$	$\beta_5 \geq 200$
Water Absorption Capacity	150 ml	300 ml	N/A	N/A	N/A	N/A	350 ml	700 ml
	5 oz	10 oz						
Nominal Flow per Element	2,1 l/min	4,2 l/min	2,1 l/min	4,2 l/min	2,1 l/min	4,2 l/min	2,1 l/min	4,2 l/min
	.6 GPM	1.2 GPM	.6 GPM	1.2 GPM	.6 GPM	1.2 GPM	.6 GPM	1.2 GPM
Max. Viscosity at Nominal Flow Rate	180 cSt	180 cSt	800 cSt	800 cSt	800 cSt	800 cSt	800 cSt	800 cSt
Max. Oil Temperature	+80 °C	+80 °C	+80 °C	+80 °C	+80 °C	+80 °C	+80 °C	+80 °C
	+176 °F	+176 °F	+176 °F	+176 °F	+176 °F	+176 °F	+176 °F	+176 °F
Length of Element	300 mm	600 mm	300 mm	600 mm	300 mm	600 mm	300 mm	600 mm
	11.8 in	23.6 in	11.8 in	23.6 in	11.8 in	23.6 in	11.8 in	23.6 in
Sealing Material (Standard)	NBR (Buna-N®) and Silicone Rubber		NBR (Buna-N®)		NBR (Buna-N®)		NBR (Buna-N®)	
Other Sealing Material	Contact STAUFF							
Fluid Compatibility:								
--Mineral Oils								
H, HI, HLP, HVLP	OK		OK		OK		OK	
-- Biodegradable Oils								
HEPG Polyethyleneglycol	Contact STAUFF							
HEES Synthetic ester	OK		OK		OK		OK	
HETG Vegetable seed oil	Contact STAUFF							
-- Fire Inhibiting Fluids								
HFA emulsions	NO		OK		OK		NO	
HFC glycol/water solution	NO		OK		OK		NO	
HFD fluids no water content	Contact STAUFF							
Approximate Weight	0,8 kg		1,25 kg		1,25 kg		1,25 kg	
	1.8 lb		2.8 lb		2.8 lb		2.8 lb	

G

Filter Element SRM-30-H-B Δp / viscosity - graph

(at a flow of 2,1 l/min / .6 US GPM per element)

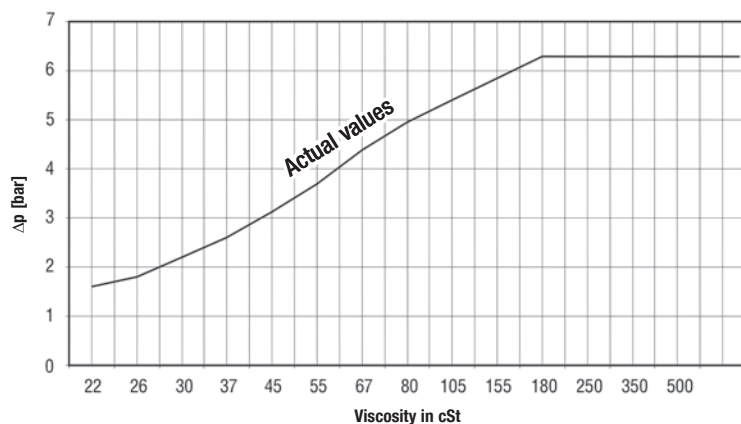

Filter Element SRM-30-E-03-B Δp / Viscosity-Graph

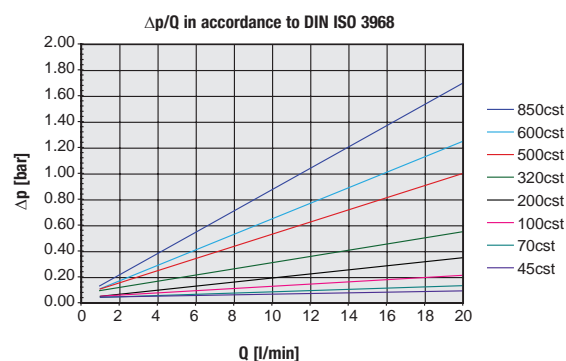

Filter Element SRM-30-E-01-B Δp / Viscosity-Graph

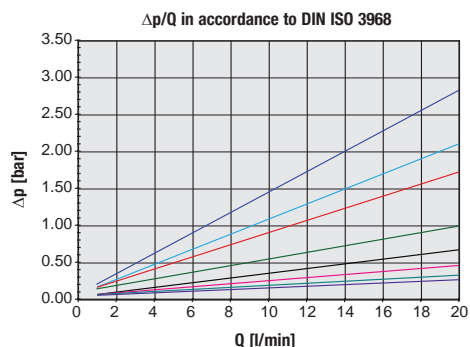

Filter Element SRM-30-EA Δp / Viscosity-Graph

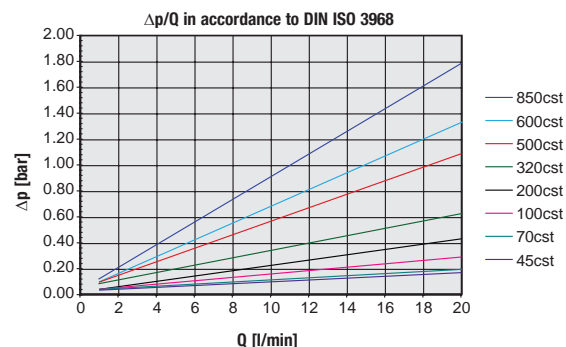

Offline Filters ■ Type OLS
Product Description

STAUFF Offline Filter Units can be applied to every imaginable industrial application where hydraulic or lubrication systems are present.

An integrated motor/pump unit draws fluid out of the tank, filters it and pumps clean oil back into the system. Offline Filter Units can continue to work even if the main system is not in use. The standard range offers filter units for reservoirs with a capacity of up to 10800 l / 2853 gal.

Over the years, STAUFF Systems have developed considerable experience in the hydraulic and lubrication market cleaning systems to levels not previously possible with conventional methods.

The OLS is available with one, two or four filter housings and in two different lengths. The maximum flow for the Offline Unit goes from 2,1 ... 17 l/min / .55 ... 4.5 US GPM at a viscosity between 20 ... 160 cSt. For the OLS you can choose several different motor/pump units, for more information please see page 188 (Order code).

**All Offline Filter Systems are available with air driven motors.
These units are ideal for areas where electric power is unavailable
or for hazardous locations.**

Single Length (see page 184 / 185)

G

Double Length (see page 186 / 187)

Offline Filters ■ Type OLS

Dimensions OLS-1-30-H-B

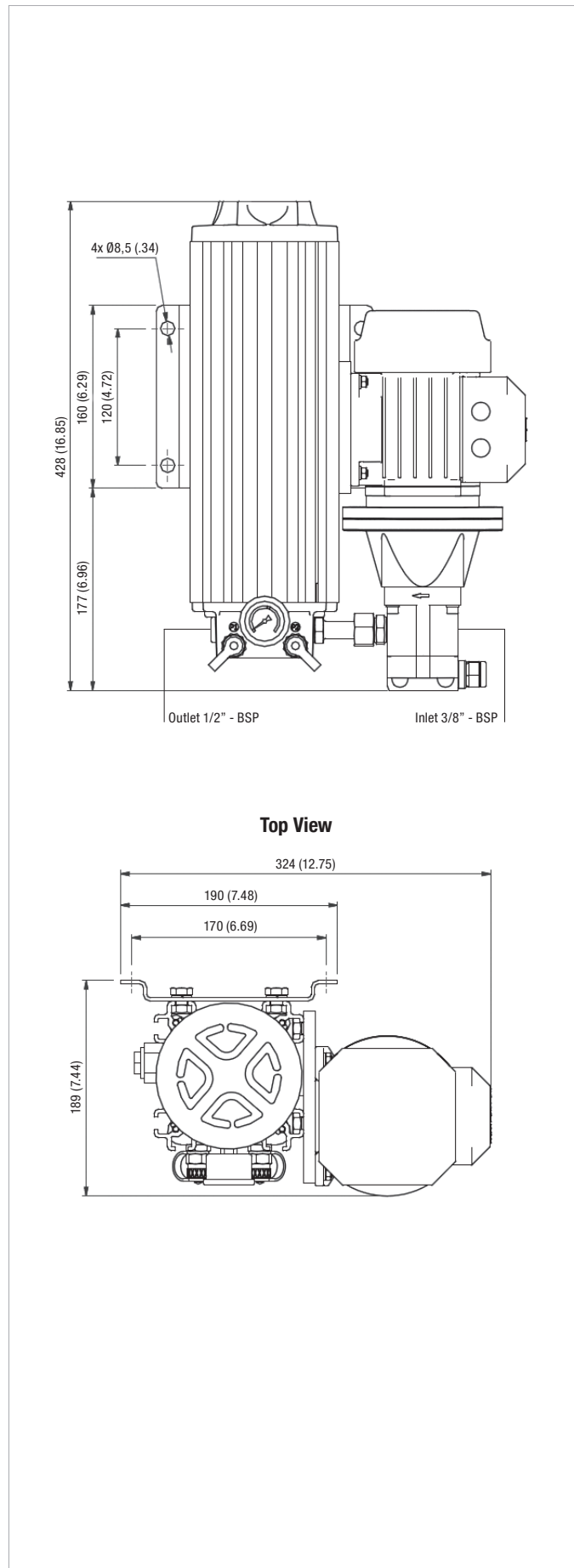

Dimensions OLS-2-30-H-B

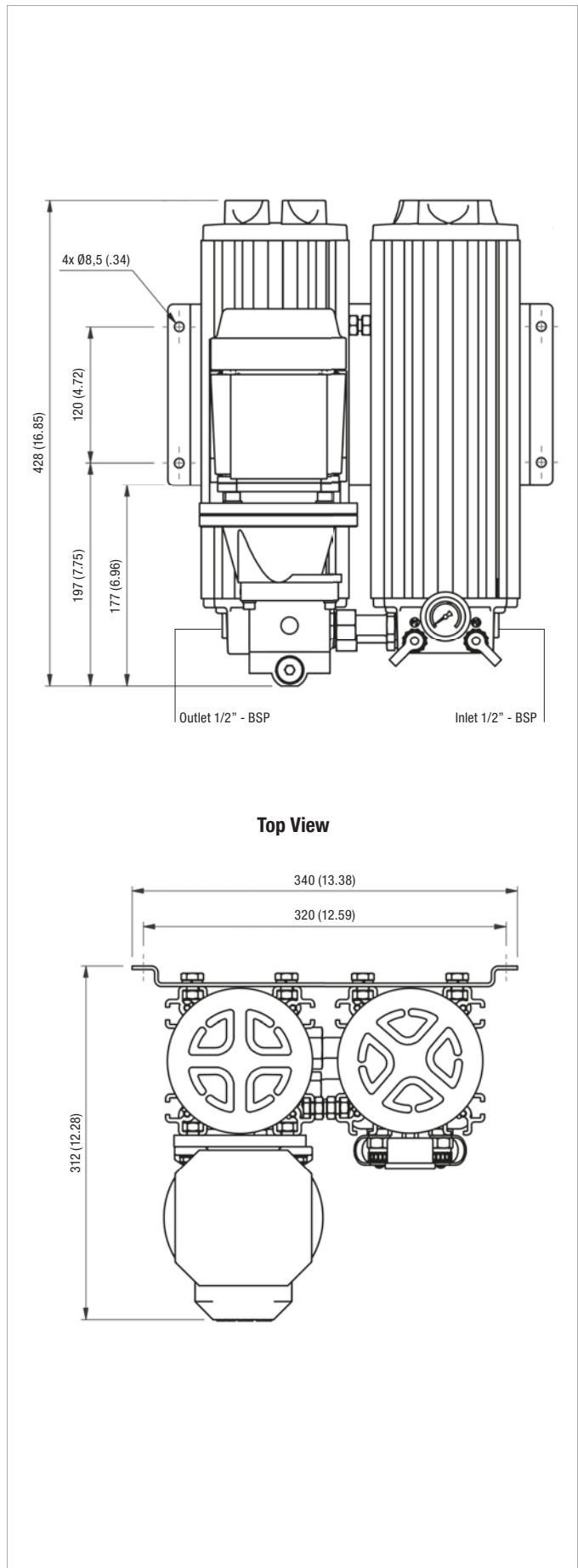

G

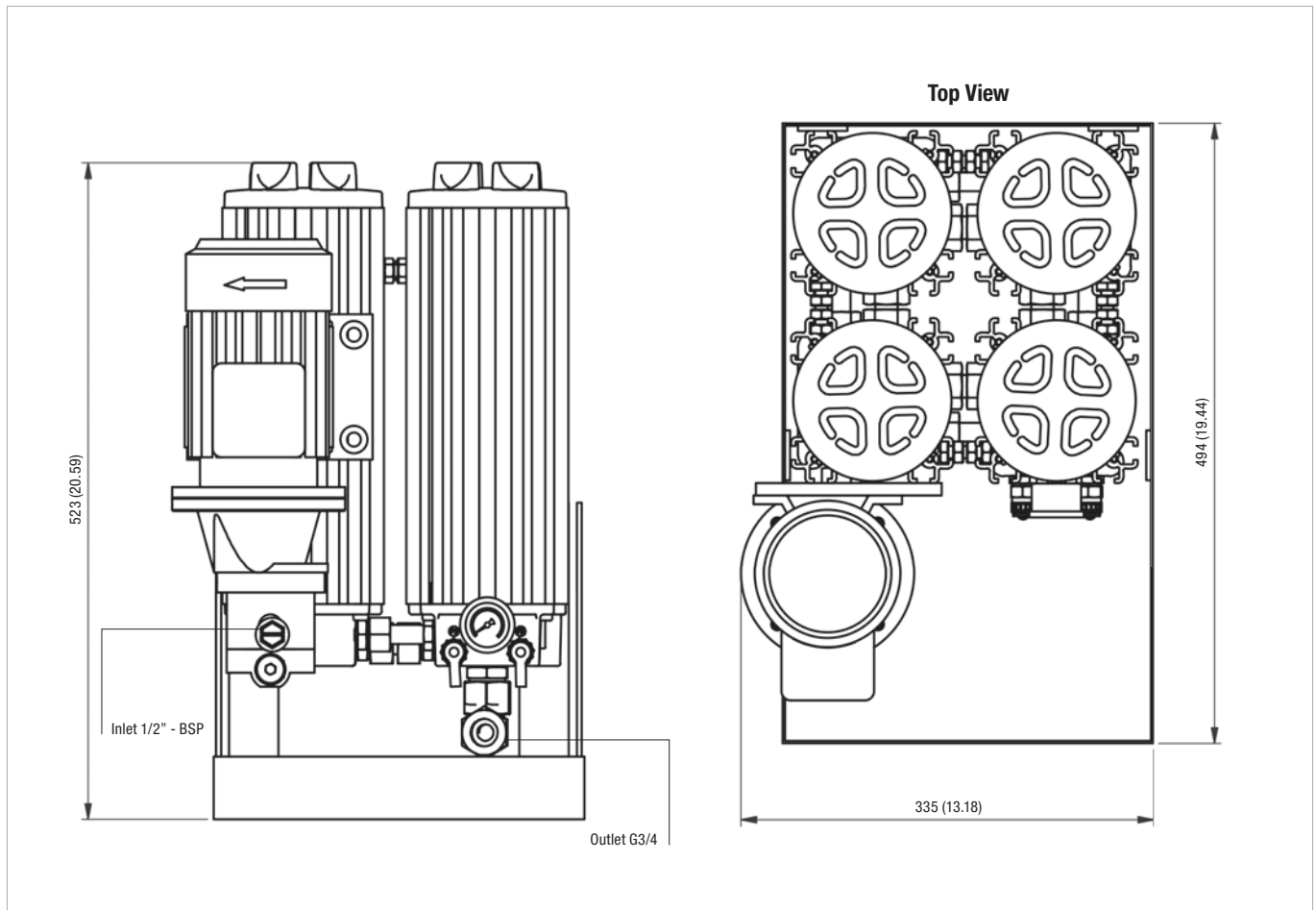
Dimensions OLS-4-30-H-B

All dimensions in mm / in

Technical Data

	OLS-1-30-H-B	OLS-2-30-H-B	OLS-4-30-H-B
Number of Filter Housings	1	2	4
Nominal Flow	2,1 l/min .55 US GPM	4,2 l/min 1.1 US GPM	8,4 l/min 2.22 US GPM
Max. Differential Pressure	6,2 bar 90 PSI		
Max. Fluid Temperature	+80 °C +176 °F		
Max. Housing Pressure	20 bar 290 PSI		
Viscosity Range	20 ... 160 cSt 100 ... 750 SUS		
Connection Suction Side	G3/8	G1/2	
Connection Return Side	G1/2		G3/4
Hose Diameter	1/2 in (inner diameter) flexible hose		3/4 in (inner diameter) flexible hose
Weight (Including Element)	14 kg 30.9 lbs	21 kg 46.3 lbs	39 kg 86 lbs
Max. System Volume	1350 l 356 gal	2700 l 713 gal	5400 l 1426 gal
Dimensions H x W x D	428 x 324 x 189 mm 16.85 x 12.75 x 7.44 in	428 x 340 x 312 mm 16.85 x 13.38 x 12.28 in	523 x 494 x 335 mm 20.59 x 19.44 x 13.18 in
Connection for Online Particle Counter	STAUFF Test (M16 x 2)		
Pump	Gear pump		
Motor	See page 188 for electric motor details		
Connection Oil-Analysis: P1 filter inlet side P2 filter outlet side	Test connector (M16 x 2) Red Test connector (M16 x 2) Yellow		

G

Offline Filters ■ Type OLS

Dimensions OLS-1-60-H-B

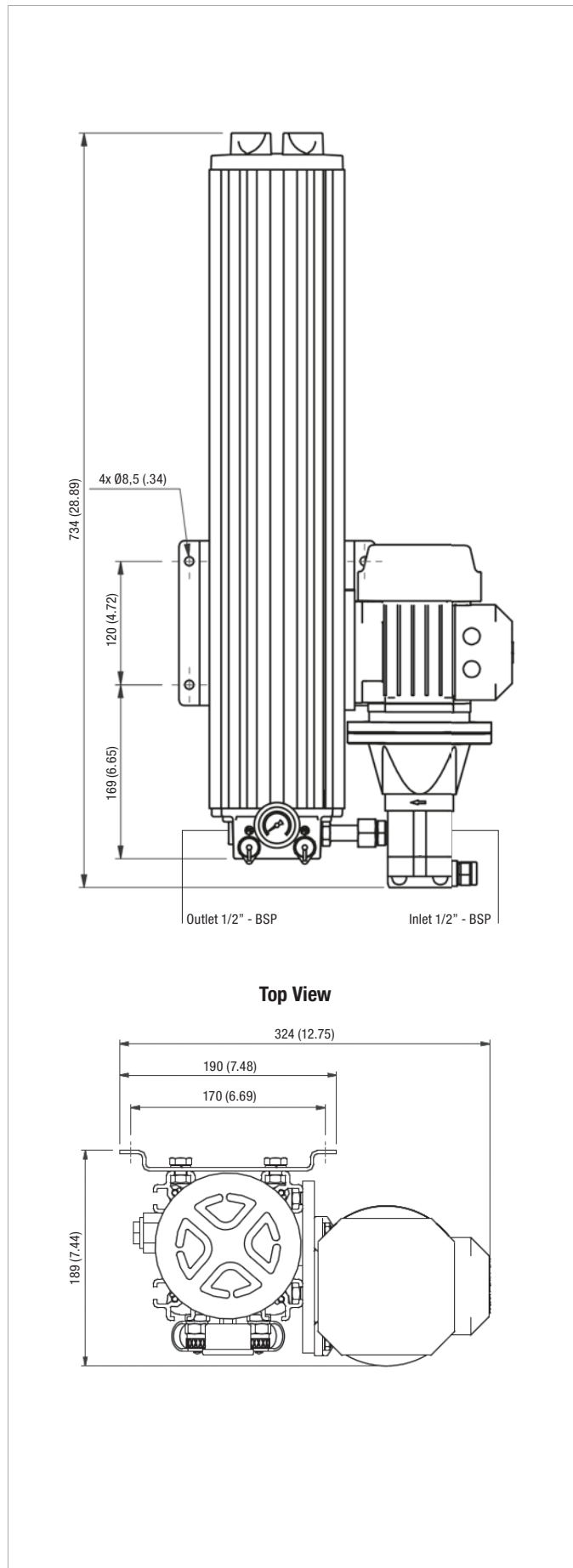

Dimensions OLS-2-60-H-B

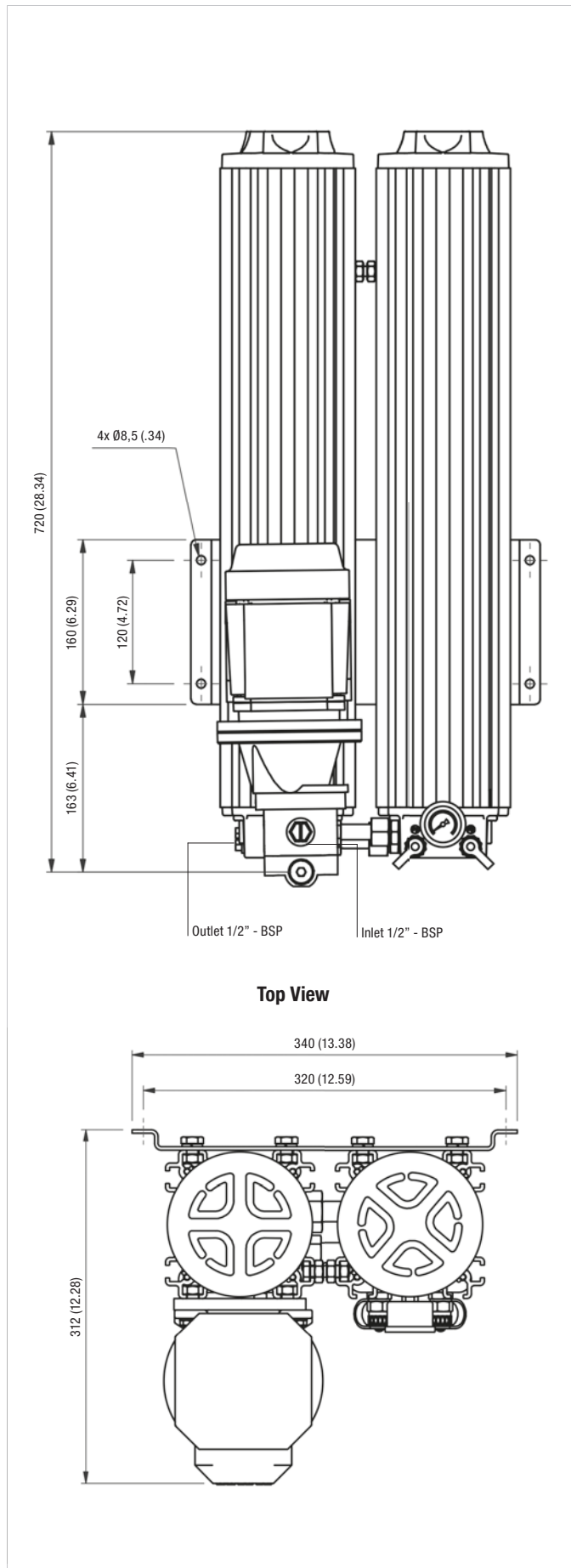

G

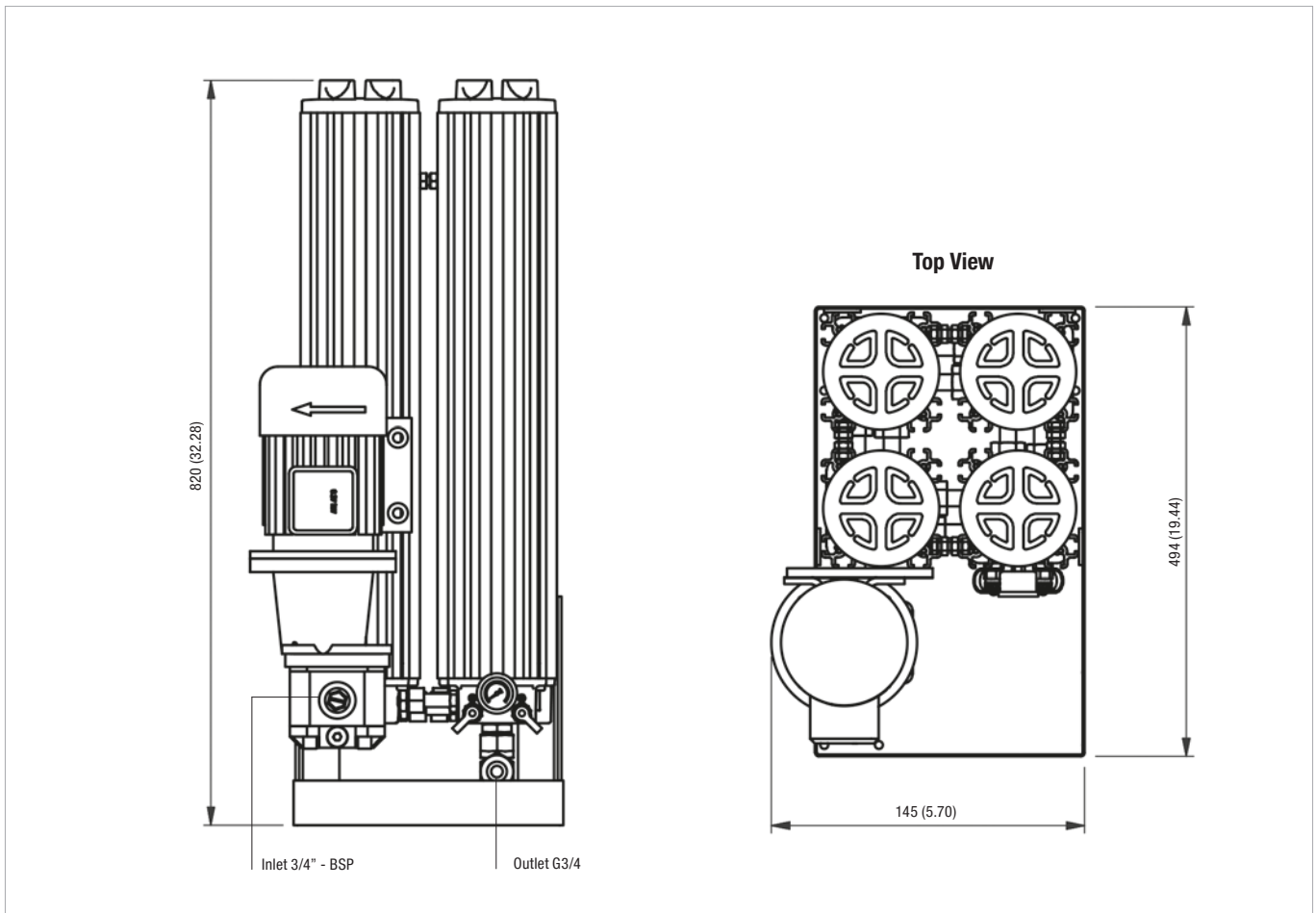
Dimensions OLS-4-60-H-B

All dimensions in mm / in

Technical Data

	OLS-1-60-H-B	OLS-2-60-H-B	OLS-4-60-H-B
Number of Filter Housings	1	2	4
Nominal Flow	4,2 l/min 1.1 US GPM	8,4 l/min 2.22 US GPM	17 l/min 4.5 US GPM
Max. Differential Pressure	6,2 bar 90 PSI		
Max. Fluid Temperature	+80 °C +176 °F		
Max. Housing Pressure	20 bar 290 PSI		
Viscosity Range	20 ... 160 cSt 100 ... 750 SUS		
Connection Suction Side	G1/2	G1/2	G3/4
Connection Return Side	G1/2		G3/4
Hose Diameter	1/2 in (inner diameter) flexible hose		3/4 in (inner diameter) flexible hose
Weight (Including Element)	18 kg 39.7 lbs	30 kg 66.1 lbs	61 kg 134.5 lbs
Max. System Volume	2700 l 713 gal	5400 l 1426 gal	10800 l 2853 gal
Dimensions H x W x D	734 x 324 x 189 mm 28.66 x 13.19 x 7.48 in	720 x 340 x 312 mm 28.90 x 13.39 x 12.72 in	820 x 494 x 145 mm 32.28 x 19.44 x 5.70 in
Connection for Online Particle Counter	STAUFF Test (M16 x 2)		
Pump	Gear pump		
Motor	See page 188 for electric motor details		
Connection Oil-Analysis: P1 filter inlet side P2 filter outlet side	Test connector (M16 x 2) Red Test connector (M16 x 2) Yellow		

Offline Filter Housings / Complete Filters - Type OLS

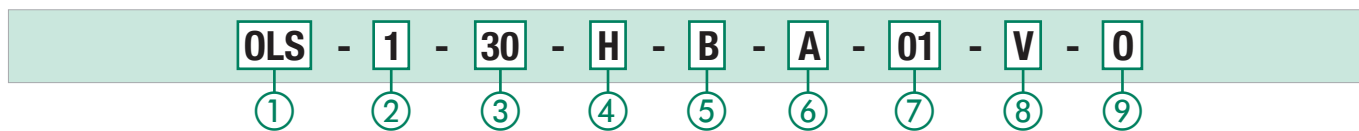

① Type

Offline Filter Unit (for industrial applications)	OLS
--	------------

② Housing Configuration

Single housing	1
Twin housing	2
Quadruple housing	4

③ Filter Element Length

300 mm / 11.81 in	30
600 mm / 23.62 in	60

④ Filter Material and Micron Rating

Material	Micron rating µm	Code
Cellulose (standard)	0,5	H
Inorg. glass fibre	1	E-01
Inorg. glass fibre	3	E-03
Inorg. glass fibre	5	E-05
Inorg. glass fibre	10	E-10
Inorg. glass fibre	20	E-20
Inorg. glass fibre and polymer (water absorption)	3*	EA-03
Inorg. glass fibre and polymer (water absorption)	5*	EA-05

* Other micron ratings on request.

⑤ Sealing Material

NBR (Buna-N®) (standard)	B
FKM (Viton®)	V

⑥ E-motor Options

Motor Type	Code
230/400 V AC, 50 Hz, three phases, 1360 r/min 255/460 V AC, 60 Hz, three phases, 1630 r/min (50 Hz and 60 Hz standard)	A
230 V AC, 50 Hz, single phase, 1360 r/min	G
110 V AC, 50 Hz, single phase	I
110 V AC, 60 Hz, single phase	J
230 V AC, 60 Hz, single phase, 1630 r/min	H

Note: Special motors on request.

⑦ Pump Options

50 Hz Motor	Standard in	Code
1,6 cc/rev.	OLS-1-30	00
3,15 cc/rev.	OLS-2-30/1-60	10
6,1 cc/rev.	OLS-4-30/2-60	20
8,2 cc/rev.		30
11,3 cc/rev.	OLS-4-60	40
0,8 cc/rev.		50

60 Hz motor	Standard in	Code
1,25 cc/rev.	OLS-1-30	01
2,5 cc/rev.	OLS-2-30/1-60	11
5,0 cc/rev.	OLS-4-30/2-60	21
6,3 cc/rev.		31
10 cc/rev.	OLS-4-60	41

⑧ Clogging Indicator

Visual clogging indicator	V
---------------------------	----------

⑨ Mounting Options

No options (standard)	0
Motor / pump right side mounted	1
Motor / pump left side mounted	2

G

Filter Elements - Type SRM

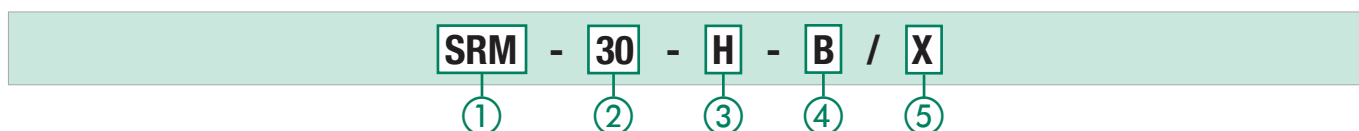

① Type

Filter Element Series	SRM
-----------------------	------------

② Filter Element Length

300 mm / 11.81 in	30
600 mm / 23.62 in	60

③ Filter Material and Micron Rating

Material	Micron rating µm	Code
Cellulose (standard)	0,5	H
Inorg. glass fibre	1	E-01
Inorg. glass fibre	3	E-03
Inorg. glass fibre	5	E-05
Inorg. glass fibre	10	E-10
Inorg. glass fibre	20	E-20
Inorg. glass fibre and polymer (water absorption)	3*	EA-03
Inorg. glass fibre and polymer (water absorption)	5*	EA-05

* Other micron ratings on request.

④ Sealing Material

NBR (Buna-N®) (standard)	B
FKM (Viton®)	V

⑤ Design Code

Only for information	X
----------------------	----------

Technical Data on Electric Motors used for OLS Filters (For air driven motors contact STAUFF)

E-motor	Standard Configuration	Description	Power in kW	Power in HP	Voltage 50 Hz	Amp 50 Hz	RPM 50 Hz	Voltage 60 Hz	Amp 60 Hz	RPM 60 Hz
I, J	OLS-1-30 OLS-2-30 OLS-1-60	M63 B3/B5 4P 110V MULTIVOLT	0,18	0,24	110 V AC	3,30		110 V AC	2,70	
G, H	OLS-1-30 OLS-2-30 OLS-1-60	M63 B3/B5 4P 230 MULTIVOLT	0,18	0,24	230 V AC	1,57		230 V AC	1,34	
A	OLS-1-30 OLS-2-30 OLS-1-60	M63 B3/B5 4P 3PH MULTIVOLT	0,18	0,24	230/400 V AC	1,03 / 0,60		254/440 V AC	0,90 / 0,52	
A	OLS-2-60 OLS-4-30	M63 B3/B5 4P 3PH MULTIVOLT	0,29	0,39	230/400 V AC	1,65 / 0,95	1460	254/440 V AC	1,47 / 0,85	1740
I, J	OLS-2-60 OLS-4-30 OLS-4-60	M71 B3/B5 4P 110V MULTIVOLT	0,37	0,50	110 V AC	6,10		110 V AC	5,20	
G, H	OLS-2-60 OLS-4-30 OLS-4-60	M71 B3/B5 4P 230V MULTIVOLT	0,37	0,50	230 V AC	3,00		230 V AC	2,65	
A	OLS-4-60	M71 B3/B5 4P 3PH MULTIVOLT	0,37	0,50	230/400 V AC	1,90 / 1,10		254/440 V AC	1,60 / 0,93	

Water Absorbing Offline Filter ■ Type OLSW
Product Description

STAUFF Systems Units are characterized by their extremely efficient filter elements which are rated to 5 micron. Specially designed for industrial hydraulic installations the STAUFF Offline Filters are available in single or double length configurations. The Offline Filter Units can easily be mounted to new and existing hydraulic installations. By means of an integrated motor/pump unit and an Offline Filter, the oil is pumped from the reservoir through the filter unit and after filtering the oil is then returned to the tank.

Economical

The hydraulic market accepts that 80 % of mechanical failures are caused by contamination in the system. The STAUFF Water Absorbing Offline Filters attack this contamination at source and in addition to solid particles, these filters are also capable of removing large quantities of water from the oil. This prevents the catalytic reaction of water and solid particle contamination, resulting in extended useable oil life.

The application of STAUFF Filters results in lower component failure rates, less down time and less system maintenance.

Water Absorbing

STAUFF Water Absorbing Filters are Offline Units that use special water absorbing Spin-On Filter Elements as a pre-filter. The fluid is pumped through the pre-filter which removes most water and larger solid contamination, in the second stage the fluid passes through the STAUFF Micro Filter where final water removal takes place as well as solid removal down to 0,5 micron.

In recent years STAUFF Systems have developed a great deal of experience in cleaning and drying hydraulic and lubrication systems in the following markets:

- Steel industry
- Maritime industry
- Petrochemical industry
- Paper industry

Advantages

- Extremely clean oil due to the high filtration efficiency $\beta_{0,5} \geq 200$, $\beta_2 \geq 2330$
- Prevention of channel forming by radial filtration direction
- Increased flow capacity
- Increased dirt-hold capacity
- Large water holding capacity
- Compact and easy-maintenance design
- Longer usage life for oil and components



Water Absorbing Offline Filter ▪ Type OLSW

Dimensions OLSW-1-30

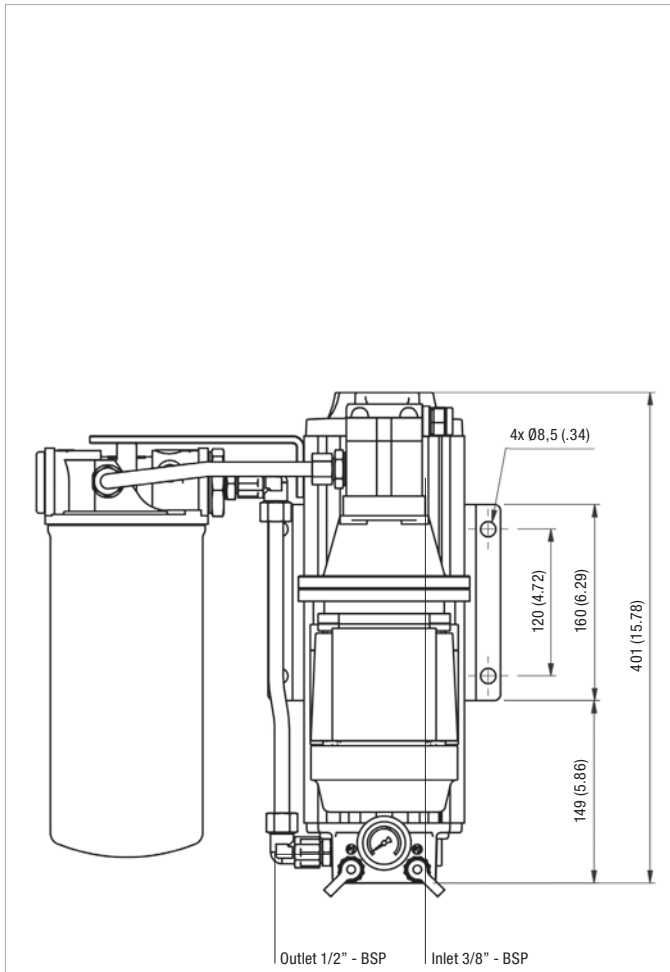

Top View

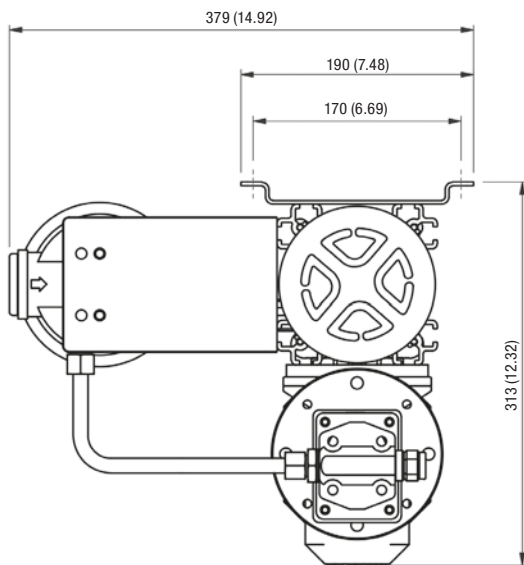

Dimensions OLSW-1-60

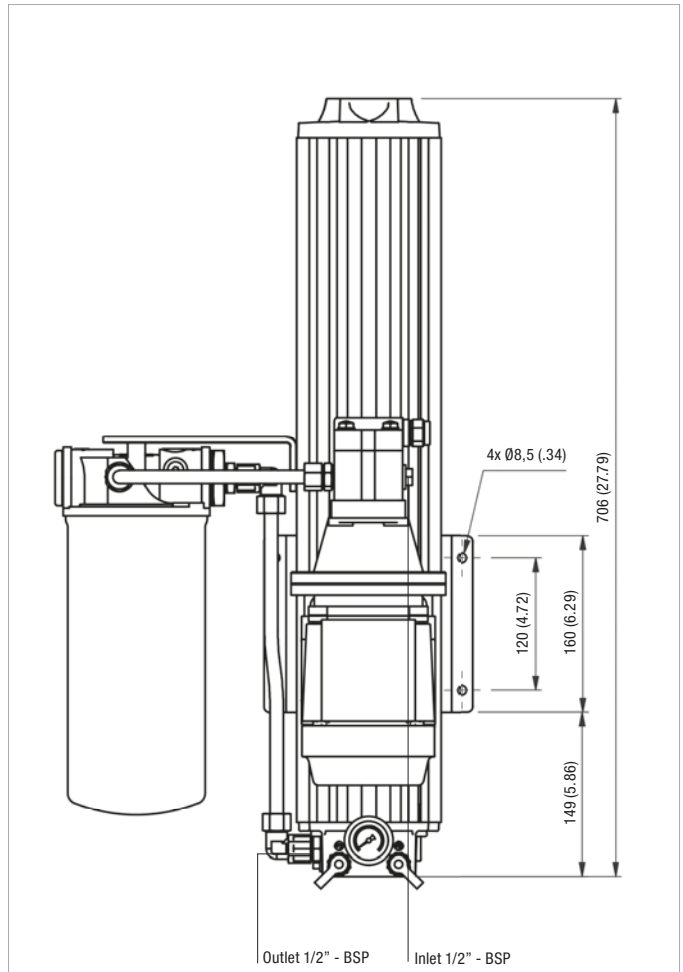

Top View

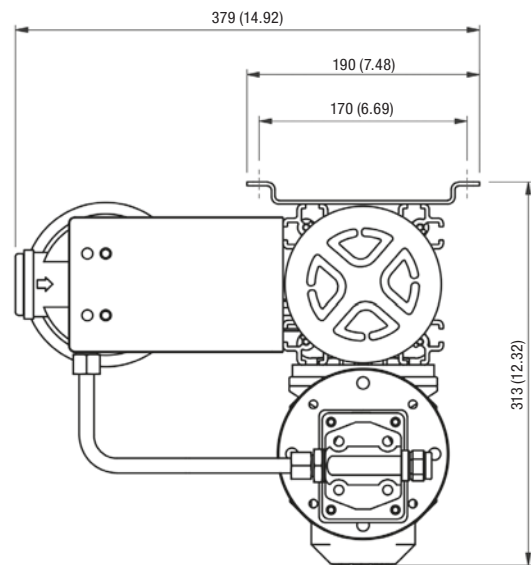

All dimensions in mm / in

Water Absorbing Offline Filter ■ Type OLSW

Dimensions OLSW-2-30

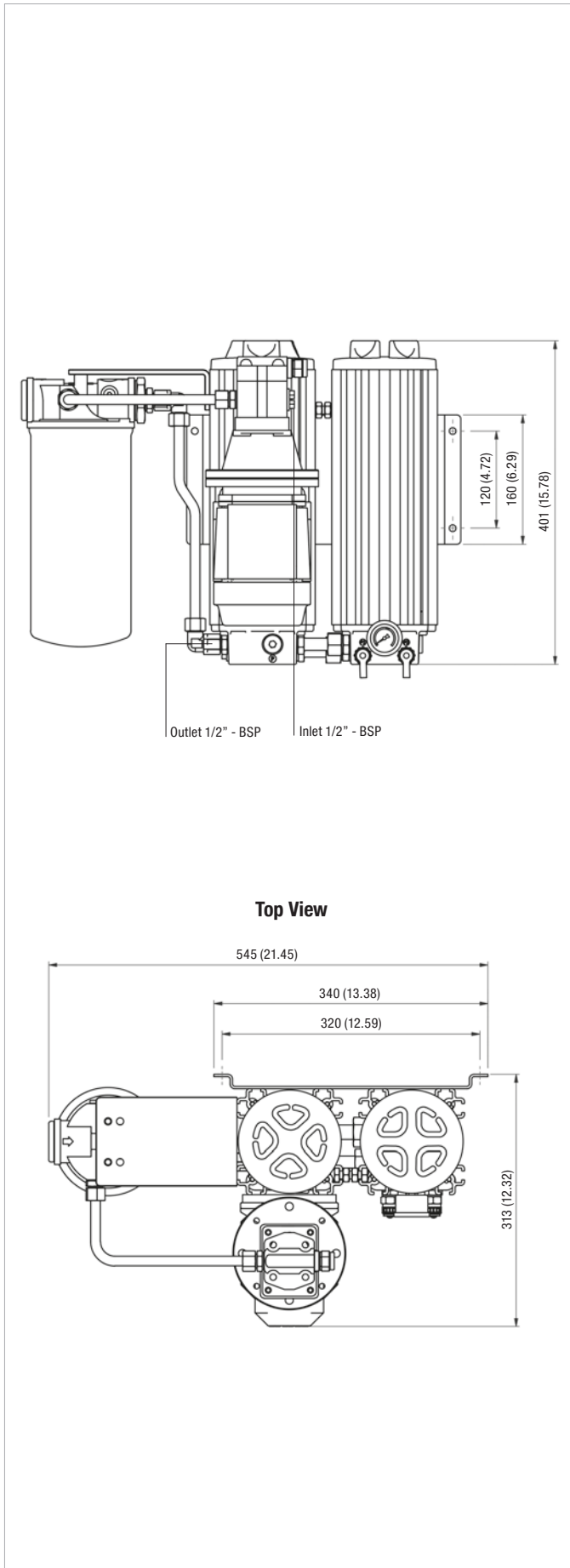

Dimensions OLSW-2-60

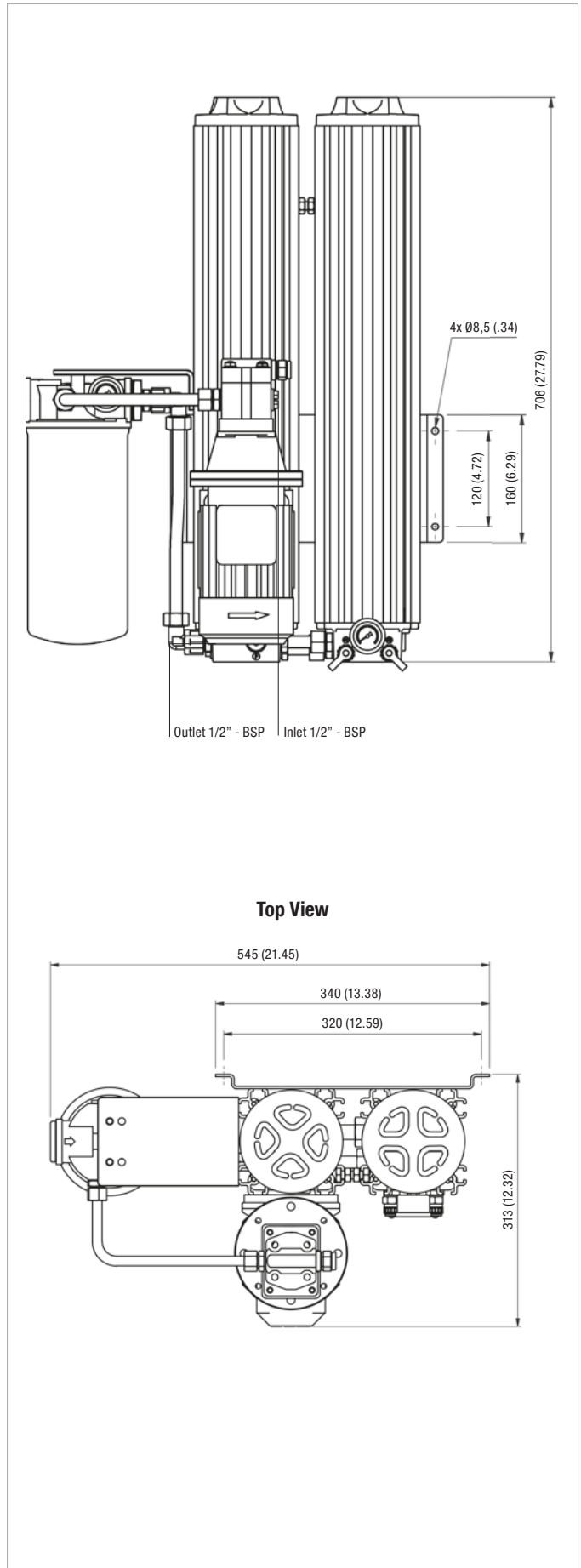

G

Water Absorbing Offline Filter ▪ Type OLSW

Dimensions OLSW-4-30

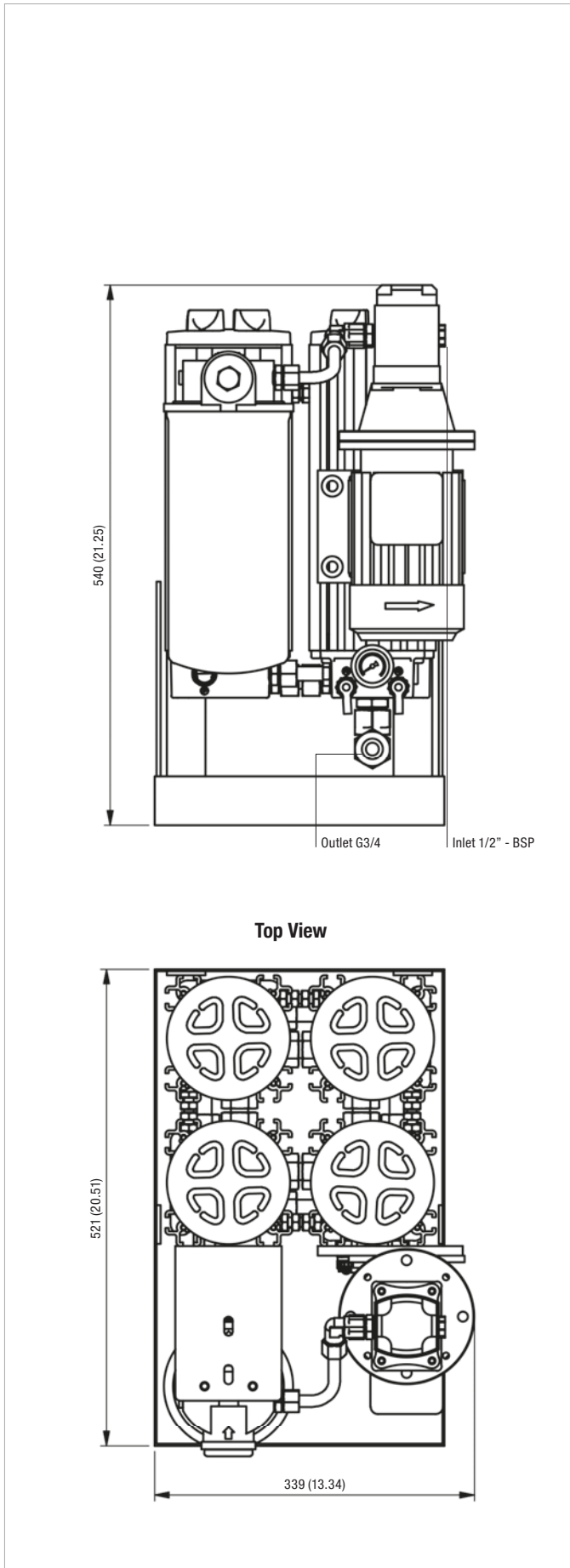

Dimensions OLSW-4-60

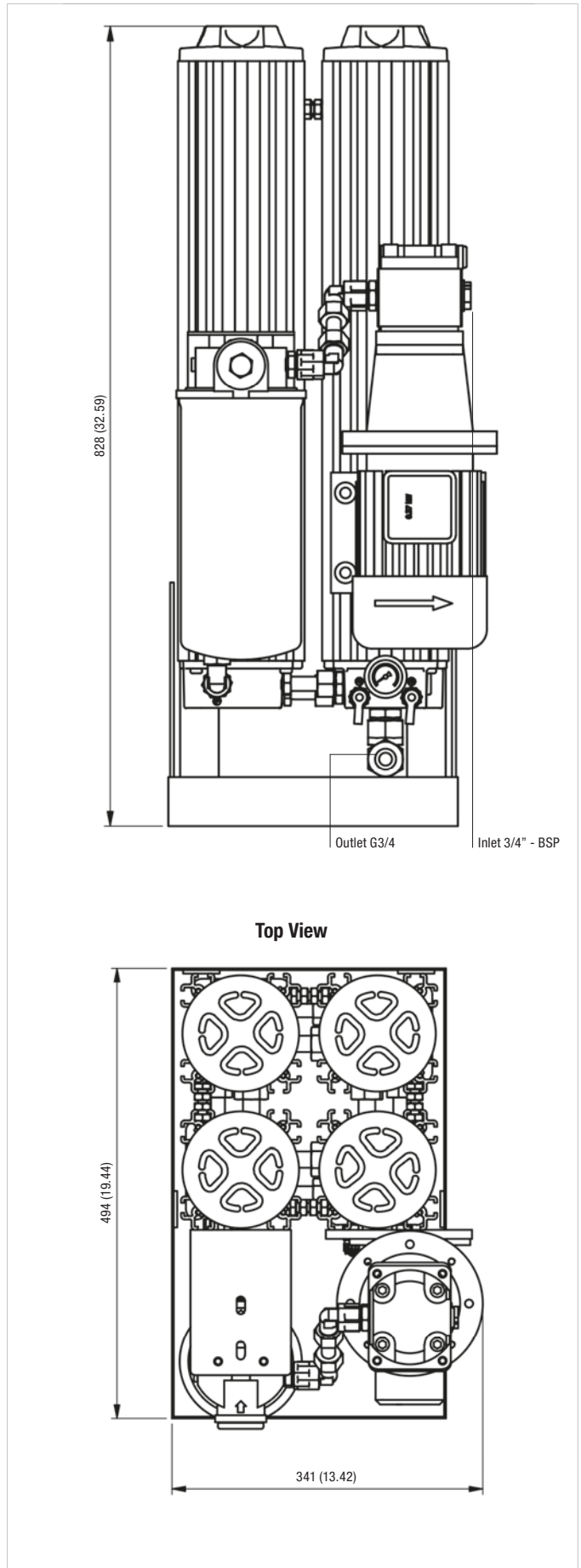

G

Water Absorbing Offline Filter ■ Type OLSW
Technical Data OLSW

	OLSW-1-30-H-B	OLSW-1-60-H-B	OLSW-2-30-H-B	OLSW-2-60-H-B	OLSW-4-30-H-B	OLSW-4-60-H-B
Number of Filter Housings	1	1	2	2	4	4
Nominal Flow	2,1 l/min .6 US GPM	4,2 l/min 1.1 US GPM	4,2 l/min 1.1 US GPM	8,4 l/min 2.2 US GPM	8,4 l/min 2.2 US GPM	16,8 l/min 4.4 US GPM
Max. Differential Pressure	6,2 bar over the filter element without backpressure 90 PSI over the filter element without backpressure					
Water Absorbing Capacity	794 ml 25 oz.	1144 ml 38 oz.	1144 ml 38 oz.	1844 ml 62 oz.	1844 ml 62 oz.	3244 ml 109 oz.
Max. Fluid Temperature	+80 °C +176 °F					
Max. Housing Pressure	20 bar 290 PSI					
Viscosity Range	20 ... 160 cSt 100 ... 750 SUS					
Connection Suction Side	G3/8	G1/2	G1/2	G1/2	G1/2	G3/4
Connection Return Side	G1/2	G1/2	G1/2	G1/2	G3/4	G3/4
Hose Diameter	1/2 in (inner diameter) flexible hose					3/4 in (inner diameter) flexible hose
Weight (including Element)	18 kg 39.7 lbs	22 kg 48.5 lbs	25 kg 55.1 lbs	34 kg 75.0 lbs	43 kg 94.8 lbs	65 kg 143.3 lbs
Max. System Volume	1350 l 356 gal	2700 l 713 gal	2700 l 713 gal	5400 l 1427 gal	5400 l 1427 gal	10800 l 2853 gal
Dimensions H x B x L	401 x 379 x 313 mm 15.78 x 14.92 x 12.32 in	706 x 379 x 313 mm 27.79 x 14.92 x 12.32 in	401 x 545 x 313 mm 15.78 x 21.45 x 12.32 in	706 x 545 x 313 mm 27.79 x 21.45 x 12.32 in	540 x 339 x 521 mm 21.25 x 13.34 x 20.51 in	928 x 341 x 494 mm 36.53 x 13.42 x 19.44 in
Pump	Gear pump					
Connection Oil-Analysis: P1 filter inlet side P2 filter outlet side	Test connector (M16 x 2) Red Test connector (M16 x 2) Yellow					

G

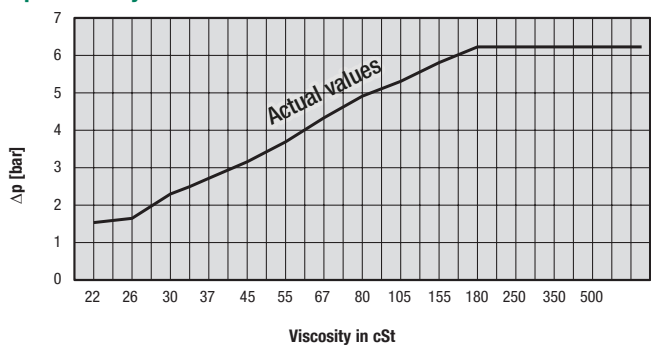
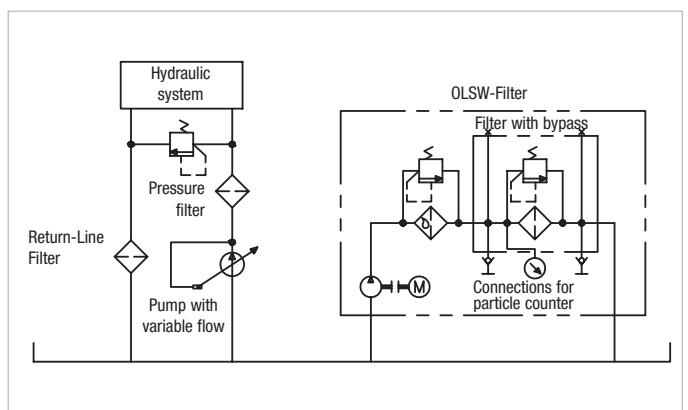
Water absorbing spin-on filter element
Δp / Viscosity for OLSW-Filter

System Example
Schematic Offline Filtration incl. Water Absorption

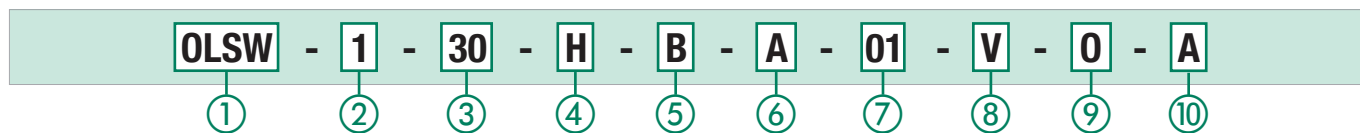
Water Absorbing Offline Filter Housings / Complete Filters ▪ Type OLSW



① Type

Offline Filter Unit incl. water absorption (for industrial applications)	OLSW
--	-------------

② Housing Configuration

Single housing	1
Twin housing	2
Quadruple housing	4

③ Filter Element Length

300 mm / 11.81 in	30
600 mm / 23.62 in	60

④ Filter Material and Micron Rating

Material	Micron rating µm	Code
Cellulose (standard)	0,5	H
Inorg. glass fibre and polymer (water absorption)	5	EA

⑤ Sealing Material

NBR (Buna-N®) (standard)	B
FKM (Viton®)	V

⑥ E-motor Options

Motor Type	Code
230/400 V AC, 50 Hz, three phases, 1360 r/min 255/460 V AC, 60 Hz, three phases, 1630 r/min (50 Hz and 60 Hz standard)	A
230 V AC, 50 Hz, single phase, 1360 r/min	G
110 V AC, 50 Hz, single phase	I
110 V AC, 60 Hz, single phase	J

Note: Special motors on request.

⑦ Pump Options

50 Hz Motor	Standard in	Code
1,6 cc/rev.	OLSW-1-30	00
3,15 cc/rev.	OLSW-1-60/2-30	10
6,1 cc/rev.	OLSW-2-60/4-30	20
11,3 cc/rev.	OLSW-4-60	40

60 Hz Motor	Standard in	Code
1,25 cc/rev.	OLSW-1-30	01
2,5 cc/rev.	OLSW-1-60/2-30	11
5,0 cc/rev.	OLSW-2-60/4-30	21
10 cc/rev.	OLSW-4-60	41

⑧ Clogging Indicator

Visual clogging indicator	V
---------------------------	----------

⑨ Mounting Options

No options (standard)	0
-----------------------	----------

⑩ Pre-Filter Elements

Water absorption element	
SF-6721-W (10 micron water absorbing, capacity 444 ml water)	A
Pre-filter elements (particles)	
without pre-filter element	0
SF-6702-MG (inorganic glass fiber, 1 micron)	B
SF-6704-MG (inorganic glass fibre, 3 micron)	C
SF-6707-MG (inorganic glass fibre, 6 micron)	D
SF-6731-MG (inorganic glass fibre, 12 micron)	E
SF-6726-MG (inorganic glass fibre, 25 micron)	F
SF-6721 (filter paper, 10 micron)	G
SF-6711 (filter paper, 25 micron)	H
SF-6791 (wire mesh, 125 micron)	J

Filter Elements ▪ Type SRM

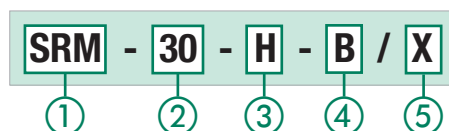

① Type

Filter Element Series	SRM
-----------------------	------------

② Filter Element Length

300 mm / 11.81 in	30
600 mm / 23.62 in	60

③ Filter Material and Micron Rating

Material	Micron rating µm	Code
Cellulose (standard)	0,5	H
Inorg. glass fibre and polymer (water absorption)	5	EA

④ Sealing Material

NBR (Buna-N®) (standard)	B
FKM (Viton®)	V

⑤ Design Code

Only for information	X
----------------------	----------

Pre-Filter Elements ▪ Type SF-67

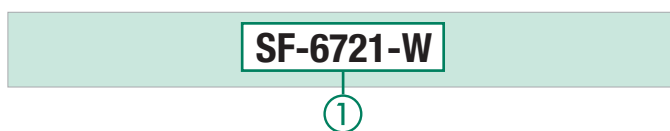

① Pre-Filter Elements

Water absorption element	
SF-6721-W (10 micron water absorbing, capacity 444 ml water)	A
Pre-filter elements (particles)	
without pre-filter element	0
SF-6702-MG (inorganic glass fiber, 1 micron)	B
SF-6704-MG (inorganic glass fibre, 3 micron)	C
SF-6707-MG (inorganic glass fibre, 6 micron)	D
SF-6731-MG (inorganic glass fibre, 12 micron)	E
SF-6726-MG (inorganic glass fibre, 25 micron)	F
SF-6721 (filter paper, 10 micron)	G
SF-6711 (filter paper, 25 micron)	H
SF-6791 (wire mesh, 125 micron)	J

Heated Offline Filters ▪ Type OLSH
Product Description

STAUFF System Units are characterized by their pre-heating unit and extremely efficient filter elements with a fineness of 0,5 micron.

Specially designed for industrial hydraulic installations, the STAUFF Offline Filters are available in single or multiple housing configurations. The Offline Filter Units can easily be mounted to new and existing hydraulic installations.

By means of an integrated motor/pump unit and an Offline Filter, the oil is pumped from the reservoir through the filter unit and after filtering the oil is then returned to the tank.

Economical

The hydraulic market accepts that 70 % of the mechanical failures are caused by contamination in the system. The STAUFF Offline Filters attack this contamination at the source. In addition to solid particles, these filters are also capable of removing water from the oil. This prevents the catalytic reaction of water and solid particle contamination, resulting in extended usable life.

The application of STAUFF Filters results in lower component failure rates, less down time and less system maintenance.

In recent years STAUFF Systems have developed a great deal of experience in cleaning and drying hydraulic and lubrication systems in the following markets:

- Steel industry
- Maritime industry
- Petrochemical industry
- Paper industry

Heated Offline Filters

The electric pre-heating ensures that the cold and/or high viscosity fluid is brought to a temperature with a suitable filtration viscosity. Offline Filters with pre-heating can be applied to new or existing installations. The integrated pump-motor combination draws fluid from the reservoir, pumps it through a heating element, filters the fluid and returns it to the reservoir.

Advantages

- Extremely clean oil due to the high filtration efficiency $\beta_{0,5} \geq 200$, $\beta_2 \geq 2330$
- Prevention of channel forming by radial filtration direction
- Increased flow capacity
- Increased dirt holding capacity
- Large water holding capacity
- Compact and easy maintenance design
- Longer usage life for oil and components



Heated Offline Filters - Type OLSH

Dimensions OLSH-1-30-H-B

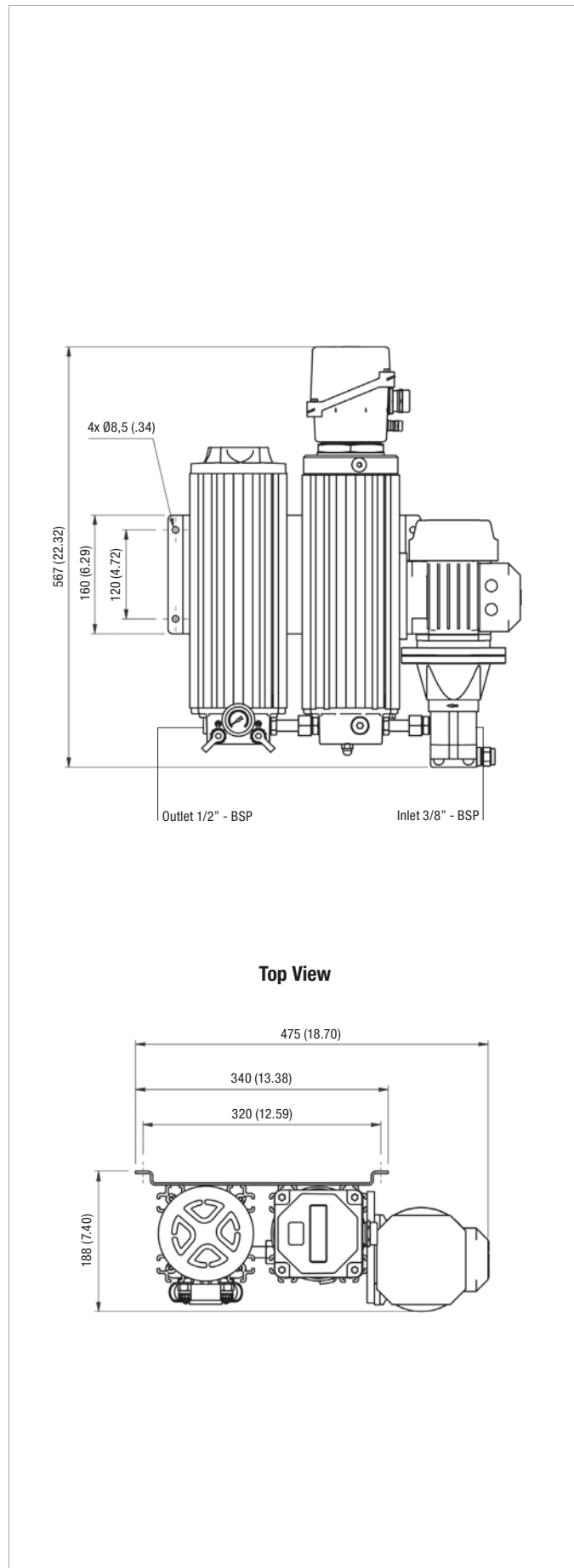

Dimensions OLSH-1-60-H-B

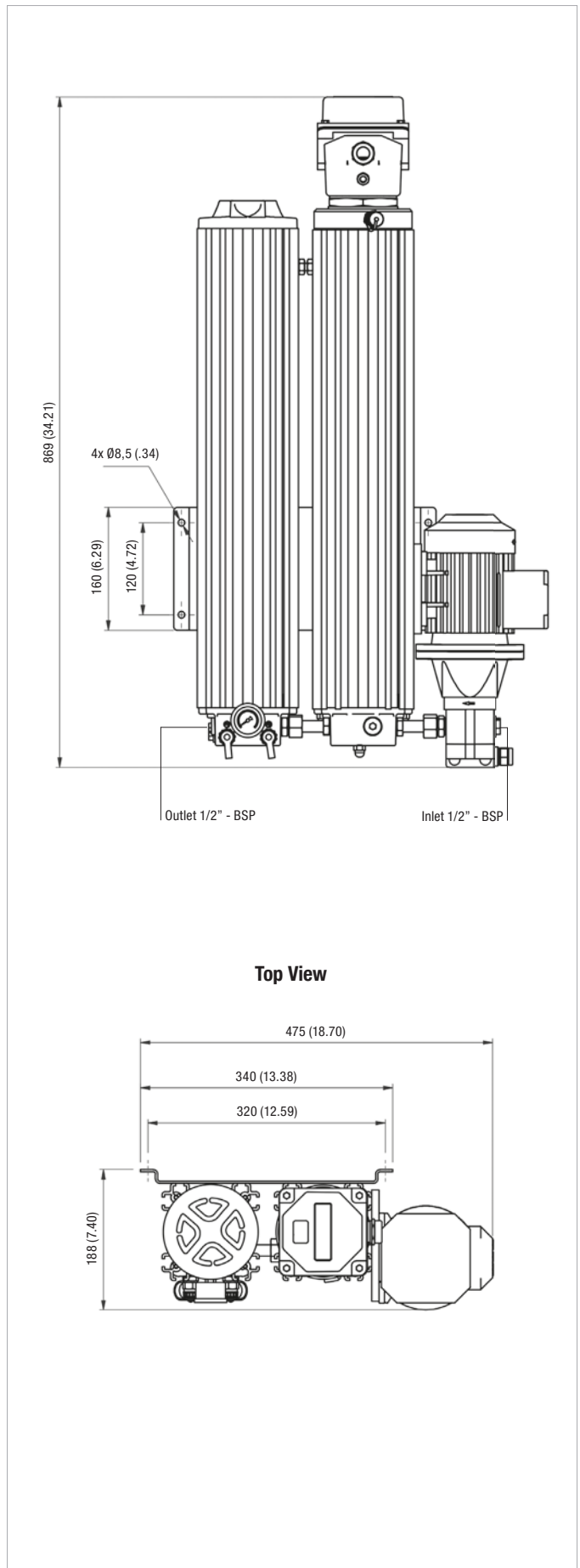

All dimensions in mm / in

Heated Offline Filters - Type OLSH
Technical Data Heated Offline Filters

	OLSH-1-30-H-B	OLSH-1-60-H-B
Number of Filter Housings	1	1
Nominal Flow	2,1 l/min .6 US GPM	4,2 l/min 1.2 US GPM
Max. Differential Pressure	6,2 bar 90 PSI	
Max. Fluid Temperature	+80 °C +176 °F	
Max. Housing Pressure	20 bar 290 PSI	
Heater Capacity	2 kW	
Connection Suction Side	G3/8	G1/2
Connection Return Side	G1/2	G1/2
Hose Diameter	1/2 in (inner diameter) flexible hose	3/4 in (inner diameter) flexible hose
Weight (including Element)	24 kg 44 lbs	28 kg 62 lbs
Max. System Volume	1350 l 356 gal	2700 l 713 gal
Dimensions H x W x D	567 x 475 x 188 mm 22.32 x 18.70 x 7.40 in	869 x 475 x 188 mm 34.21 x 18.70 x 7.40 in
Connection for Online Particle Counter	STAUFF Test (M16 x 2)	STAUFF Test (M16 x 2)
Pump	Gear Pump	
Motor	See page 196 for electric motor details	
Connection Oil-Analysis: P1 filter inlet side P2 filter outlet side	Test connector (M16 x 2) Red Test connector (M16 x 2) Yellow	

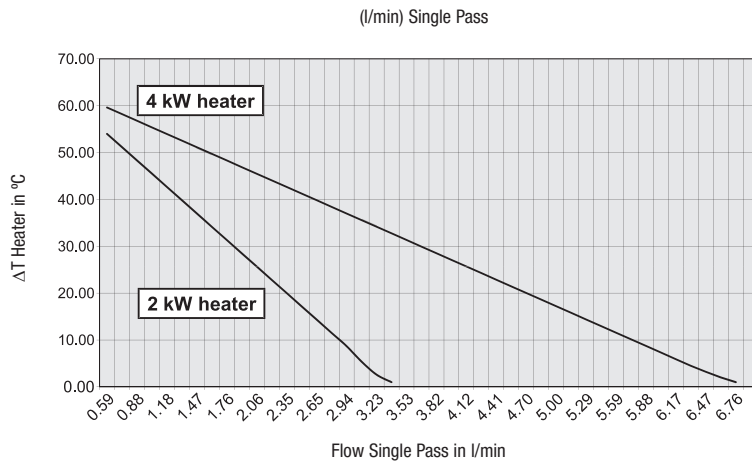
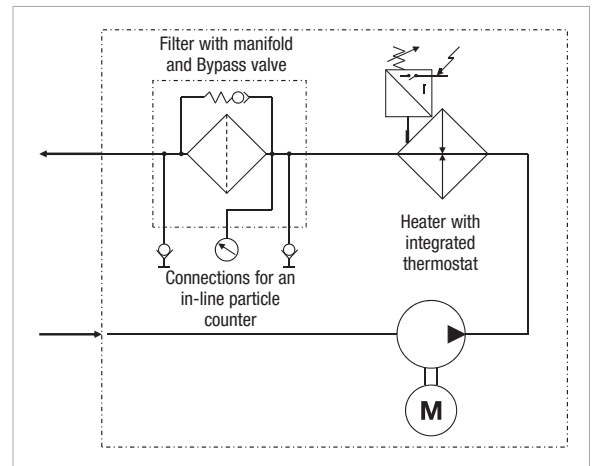
G
STAUFF Heating Efficiency Curve

Heated Unit Hydraulic Schematic

Heated Offline Filter Housings / Complete Filters ▪ Type OLSH

OLSH - 1 - 30 - H - B - A - 00 - V - 0

① ② ③ ④ ⑤ ⑥ ⑦ ⑧ ⑨

① Type
Heated Offline Filter Unit (for industrial applications) **OLSH**

② Housing Configuration
Single housing **1**

③ Filter Element Length
300 mm / 11.81 in **30**
600 mm / 23.62 in **60**

④ Filter Material

Material	Micron Rating µm	Code
Cellulose (standard)	0,5	H
Inorg. glass fibre	1	E-01
Inorg. glass fibre	3	E-03
Inorg. glass fibre	5	E-05
Inorg. glass fibre	10	E-10
Inorg. glass fibre	20	E-20
Inorg. glass fibre and polymer (water absorption)	5	EA

⑤ Sealing Material
NBR (Buna-N®) (standard) **B**
FKM (Viton®) **V**

⑥ E-Motor Options

Type	Code
230/400 V AC, 50 Hz, three phases, 1360 r/min 255/460 V AC, 60 Hz, three phases, 1630 r/min (50 Hz and 60 Hz standard)	A
230 V AC, 50 Hz, single phase	G
230/400 V AC, 50 Hz, three phases, IP65	A-IP65
230 V AC, 60 Hz, single phase, 1630 r/min	H

Note: Special motors on request.

⑦ Pump Options

Standard for 50 Hz Motor	Standard for	Code
1,6 cc/rev.	OLSH-1-30-H-B	00
3,15 cc/rev.	OLSH-1-60-H-B	10
1.0 cc / rev.		60

60 Hz Motor	Standard in	Code
1,25 cc / rev.	OLSH-1-30-H-B	01
2,5 cc / rev.	OLSH-1-60-H-B	11

⑧ Clogging Indicator
Visual clogging indicator **V**

⑨ Mounting Options
No options (standard) **0**

Filter Elements ▪ Type SRM

SRM - 30 - H - B / X

① ② ③ ④ ⑤

① Type
Filter Element Series **SRM**

② Filter Element Length
300 mm / 11.81 in **30**
600 mm / 23.62 in **60**

③ Filter Material and Micron Rating

Material	Micron rating µm	Code
Cellulose (standard)	0,5	H
Inorg. glass fibre	1	E-01
Inorg. glass fibre	3	E-03
Inorg. glass fibre	5	E-05
Inorg. glass fibre	10	E-10
Inorg. glass fibre	20	E-20
Inorg. glass fibre and polymer (water absorption)	5	EA

④ Sealing Material
NBR (Buna-N®) (standard) **B**
FKM (Viton®) **V**

⑤ Design Code
Only for information **X**

Bypass Filters ▪ Type BPS
Description

STAUFF BPS Bypass Filter can be used for OEM first fit applications as well as for retro-fitting. The filtration is done in a bypass configuration from the main hydraulic system.

The STAUFF BPS Filter Systems are available with one filter housing (BPS-1A, maximum flow 2,1 l/min / .6 US GPM) or with two filter housings (BPS-2A, maximum flow 4,2 l/min / 1.1 US GPM) at a viscosity between 20 ... 160 cSt. The STAUFF Bypass Filter Units are especially designed for mobile applications in hydraulic and/or transmission systems.

In the absence of a pumped system, the oil is drawn from the main system by means of a specially designed and integrated flow valve. The amount of oil extracted at any time is insignificant therefore ensuring that it will not affect the working of the main system. Most commonly used biodegradable oils in the mobile sector are suitable for filtration with STAUFF Filter Elements.

STAUFF Systems have been applied on a wide range of mobile hydraulic machinery, cleaning fluids to levels not previously possible with conventional filtration methods, resulting in dramatic increases in component life.

Material

- Housing: Anodized Aluminium

Differential Pressure

- Max. 6,2 bar / 90 PSI

Temperature Range

- Max. +80 °C / +176 °F media temperature

Media Compatibility

- Mineral and lubrication oils, others on request

Options and Accessories (only for BPS)
Clogging Indicators

- Visual clogging indicators

Valves

- Available with flow control valve

Type BPS

- Bypass filter units are especially designed for mobile applications in hydraulic and/or transmission systems
- No special motor-pump unit is required
- Housing pressure: max. 20 bar / 290 PSI
- Nominal flow rate: max. 4,2 l/min / 1.1 US GPM
- System volume: max. 1350 l / 356 gal
- Connections: G1/4, G1/2
- Pressure range: 12 ... 420 bar / 180 ... 6200 PSI

Type BPS

- Bypass filter units are especially designed for mobile applications in hydraulic and/or transmission systems
- No special motor-pump unit is required
- Housing pressure: max. 20 bar / 290 PSI
- Nominal flow rate: max. 4,2 l/min / 1.1 US GPM
- System volume: max. 2700 l / 713 gal
- Connections: G1/4, G1/2
- Pressure range: 12 ... 420 bar / 180 ... 6200 PSI

Bypass Filters - Type BPS

Dimensions BPS-1-30-H-B

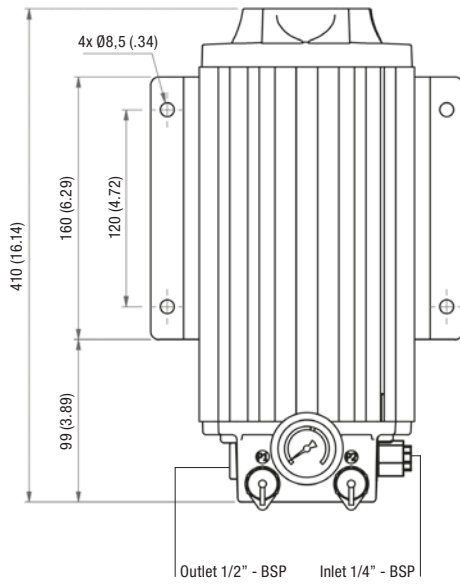

Top View

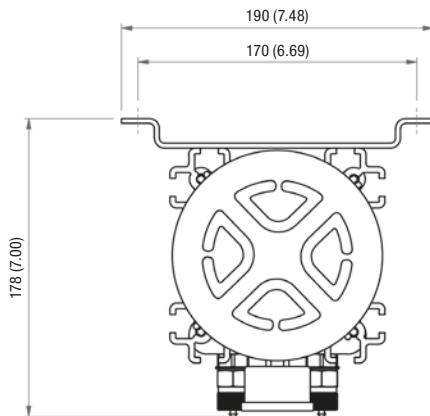

Dimensions BPS-2-30-H-B

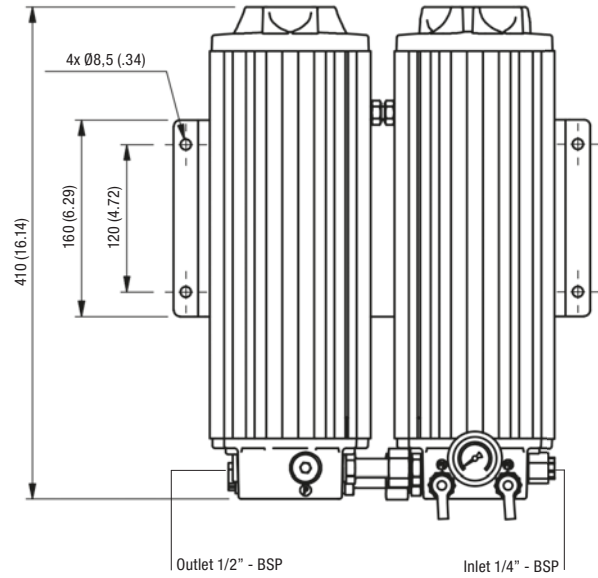

Top View

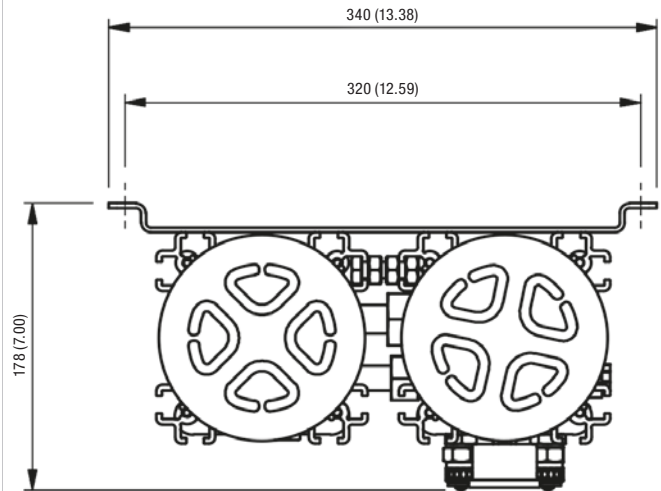

Technical Data BPS

	BPS-1-30-H-B	BPS-2-30-H-B
Number of Filter Housings	1	2
Nominal Flow Rate	2,1 l/min .6 US GPM	4,2 l/min 1.1 US GPM
Max. Differential Pressure	6,2 bar over the filter element without back pressure 90 PSI over the filter element without back pressure	
Max. Fluid Temperature	+80 °C +176 °F	
Max. Housing Pressure	20 bar 290 PSI	
Viscosity Range	20 ... 160 cSt 100 ... 750 SUS	
Connection Pressure Side	G1/4	
Connection Return Side	G1/2	
Hose Diameter	3/8 ... 1/2 in (inner diameter) flexible hose	
Weight (including Element)	6 kg 13.2 lbs	13 kg 28.7 lbs
Max. System Volume	750 l 200 gal	1500 l 400 gal
Dimensions H x W x D	410 x 190 x 178 mm 16.14 x 7.48 x 7.00 in	410 x 340 x 178 mm 16.14 x 13.38 x 7.00 in
Connection for On-Line Particle Counter	STAUFF Test (M16 x 2)	
Pressure Range	12 ... 420 bar 180 ... 6200 PSI	
Connection Oil-Analysis: P1 filter inlet side P2 filter outlet side	Test connector (M16 x 2) Red Test connector (M16 x 2) Yellow	

G
Bypass Filter Housings / Complete Filters ▪ Type BPS

BPS - 1 - 30 - H - B - V - 0 - 0

1
 2
 3
 4
 5
 6
 7
 8

① Type

Bypass Filter Unit (for mobile applications)	BPS
--	------------

② Housing Configuration

Single housing	1
Twin housing	2

③ Filter Element Length

300 mm / 11.81 in	30
-------------------	-----------

④ Filter Material and Micron Rating

Material	Micron Rating µm	Code
Cellulose (standard)	0,5	H
Inorg. glass fibre	1	E-01
Inorg. glass fibre	3	E-03
Inorg. glass fibre	5	E-05
Inorg. glass fibre	10	E-10
Inorg. glass fibre	20	E-20
Inorg. glass fibre and polymer (water absorption)	5	EA

⑤ Sealing Material

NBR (Buna-N®) (standard)	B
FKM (Viton®)	V

⑥ Clogging Indicator

Visual clogging indicator	V
---------------------------	----------

⑦ Valve Options

With flow control valve (standard)	0
Without flow control valve	1

⑧ Mounting Options

No bracket (standard)	0
With standard foot / bulk head mounting bracket	1
With "bulk head mounting only" bracket	2
With standard 'OLS' wall mounting bracket	3

Filter Elements ▪ Type SRM

SRM - 30 - H - B / X

1
 2
 3
 4
 5

① Type

Filter Element Series	SRM
-----------------------	------------

② Filter Element Length

300 mm / 11.81 in	30
-------------------	-----------

③ Filter Material and Micron Rating

Material	Micron Rating µm	Code
Cellulose (standard)	0,5	H
Inorg. glass fibre	1	E-01
Inorg. glass fibre	3	E-03
Inorg. glass fibre	5	E-05
Inorg. glass fibre	10	E-10
Inorg. glass fibre	20	E-20
Inorg. glass fibre and polymer (water absorption)	5	EA

④ Sealing Material

NBR (Buna-N®) (standard)	B
FKM (Viton®)	V

⑤ Design Code

Only for information	X
----------------------	----------

Bypass and Offline Filters ▪ Type OLS / BPS

Offline Filter OLS Hydraulic Symbol

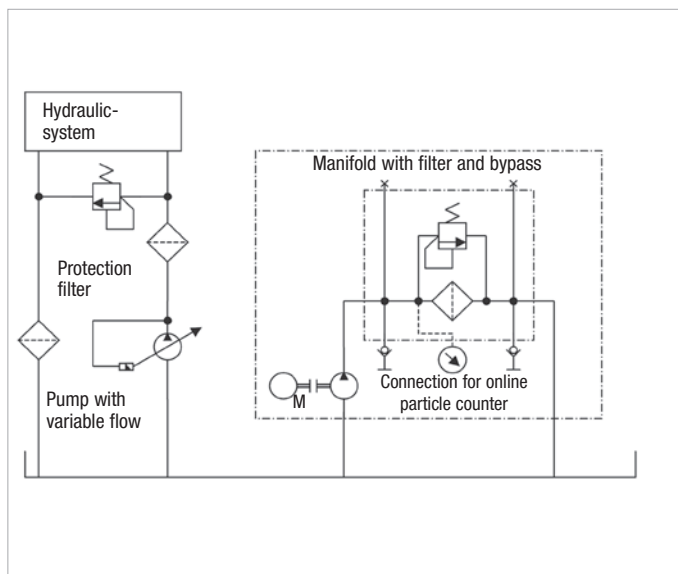

Bypass Filter BPS Hydraulic Symbol

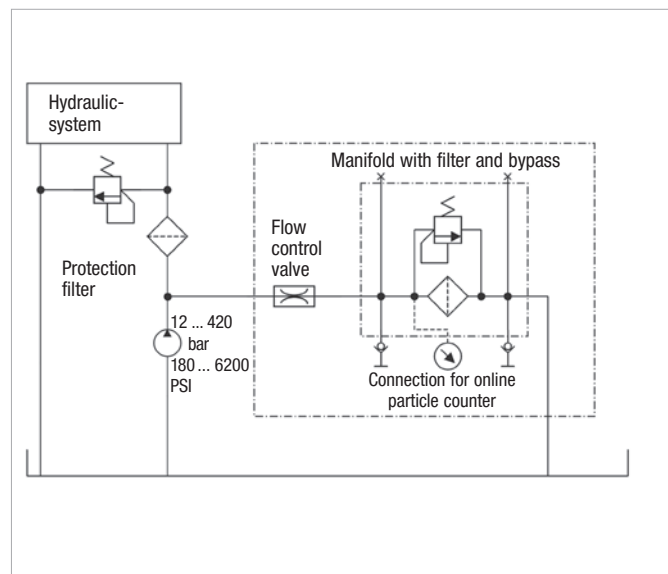

G

Filter Element SRM-30-HB Δp / viscosity - graph

(at a flow of 2,1 l/min / .6 US GPM per element)

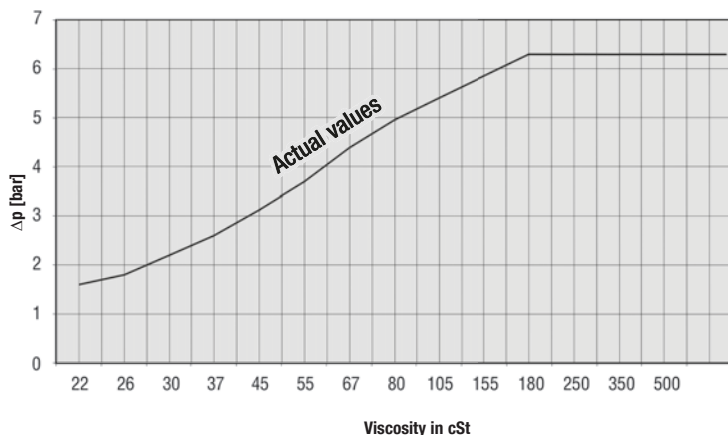

Flow Characteristics Offline Filter OLS with Filter Element SRM-30-H-B (at maximum viscosity)

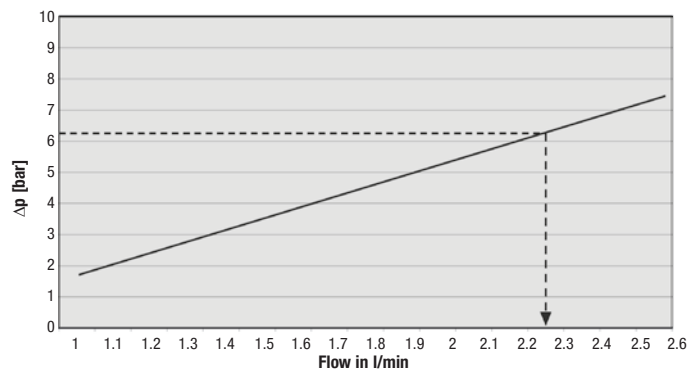

Flow Characteristics Bypass Filter BPS with Filter Element SRM-30-H-B (at maximum viscosity)

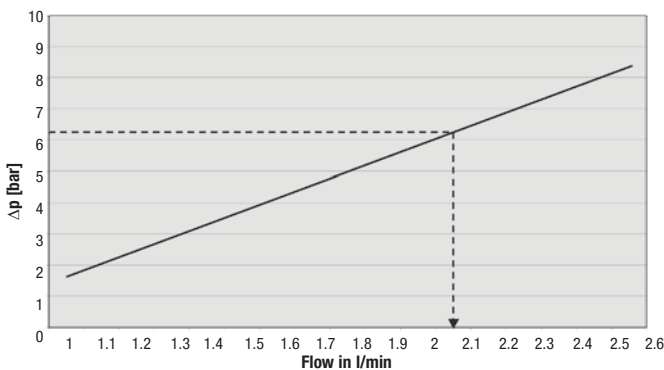

Filtration Systems 208 - 209

STAUFF Europe Filter Systems 208

STAUFF America Filter Systems 209

STAUFF Australia Filter Systems 209

STAUFF Europe

Product Description

STAUFF Mobile Filtration Systems type SMFS are designed to cover a wide application range in the area of offline-filtration.

Being compact, powerful and robust the units assist the preventive maintenance, either when transferring fresh oils or purifying existing hydraulic and lubrication oil systems.

By selecting high-quality components, the SMFS is suitable for purifying small and medium size systems in a very short time or for a permanent offline-filtration on large hydraulic systems.

- High nominal flow rates of 15 l/min / 4 US GPM respectively 110 l/min / 30 US GPM by using high-quality gear pumps and energy-efficient, high-performance three phase motors suitable for continuous duty cycle
- Flexible use (mobile or stationary offline-filtration, filter elements available in different micro ratings)
- All Units are equipped with a 200 µm pre filter
- Drip pan for residual oil
- Easy and safe handling
- Rugged construction
- Filter elements with 4Pro media provide high dirt holding capacity and filtration performance
- Made in Germany

H



Type SMFS-P-015

- Portable hand-held unit
- Compact and light-weight design
- Very flexibility
- High-quality gear pump
- Nominal flow rate: max. 15 l/min / 4 US GPM
- Motor versions: 230 V 50 Hz or 400 V 50 Hz
- Micron rating available from 3 ... 125 µm
- Also available with a blank filter element for the reason of used oil to be removed from the hydraulic reservoir
- Weight: approx. 33 kg / 73 lbs



Type SMFS-U-060

- Mobile Filtration system
- High nominal flow rates
- Long-term operating times
- High-quality gear pump
- Nominal flow rate: max. 60 l/min / 15 US GPM
- Motor unit 400 V 50 Hz
- Micron rating available from 3 ... 125 µm
- Weight: approx. 165 kg / 364 lbs



Type SMFS-U-030

- Mobile Filtration system
- Robust steel frame push cart
- Maximum flexibility
- High-quality gear pump
- Nominal flow rate: max. 30 l/min / 8 US GPM
- Motor versions: 230 V 50 Hz or 400 V 50 Hz
- Micron rating available from 3 ... 125 µm
- Water absorbing element SF-6721-W
- Also available with a blank filter element for the reason of used oil to be removed from the hydraulic reservoir
- Weight: approx. 58,5 kg / 129 lbs



Type SMFS-U-110

- Mobile Filtration system
- High nominal flow rates
- Long-term operating times
- High-quality gear pump
- Nominal flow rate: max. 110 l/min / 30 US GPM
- Motor unit 400 V 50 Hz
- Micron rating available from 3 ... 125 µm
- Weight: approx. 177,2 kg / 391 lbs



Type SMFS-U-DL-015-G

- Extremely robust transport cart
- Heavy-duty rollers, steerable and with locking device on the rear end
- Convenient filling nozzle
- High-quality gear pump
- for 200 l / 52 US GAL oil drums
- Nominal flow rate: max. 15 l/min / 4 US GPM
- Motor versions: 230 V 50 Hz
- Spin-On filter Element of the series SFC-57/58 including visual clogging indicator
- Micron rating available from 3 ... 125 µm
- Water absorbing element SF-6721-W
- Weight: approx. 85 kg / 187 lbs (without oil drum)



Type SMFS-U-CM-110

- Mobile Filtration system
- High nominal flow rates
- Long-term operating times
- High-quality gear pump
- Integrated 8-channel particle counter
- Nominal flow rate: max. 110 l/min / 30 US GPM
- Motor unit 400 V 50 Hz
- Micron rating available from 3 ... 125 µm
- Weight: approx. 220 kg / 485 lbs

Product Description

The Stauff portable filter carts, (SCFC & SPFC models), are very complete and efficient units capable of off line filtration, filling or emptying reservoirs or any application requiring the transfer or filtration of hydraulic fluid. Multi stage filtration can be achieved to extend element life. Both units are available with a variety of different spin on elements for quick and easy change to match the application requirements.

The SCFC is a very lightweight and compact cart perfect for most maintenance departments. The cart is assembled with either a single or double head allowing for flexibility.

The SPFC comes standard with a suction element, (125 µm), and two double heads which maximizes the carts filtration capabilities. It is also available as a Condition and Monitoring cart which incorporates Stauff's LPM-II Particle monitor for accurate monitoring of the fluids cleanliness condition.



Type SCFC-05 / 10

- Flow capability of 19 l/min / 5 GPM or 38 l/min / 10 GPM
- Single or three phase electric motor-1HP
- Thermal overload relays
- Welded frame cart
- Filter head with by-pass valve
- Visual clogging indicator
- On/Off buttons
- Weight: 52 kg / 115 lbs



Type SPFC-10

- Flow capability of 38 l/min / 10 GPM
- On/Off buttons with 10 foot power cord
- Single or three phase motor-1HP
- Heavy duty welded frame with drip pan and tool tray
- 3-way ball valve to by pass filters
- 3/6/12/25 µm and water absorption filter elements available
- Available as a drum cart
- Optional Condition and monitoring configuration
- Weight: 86 kg / 190 lbs



STAUFF Australia and New Zealand

Product Description

STAUFF Mobile Filtration Systems type SPFC is designed to cover a wide application range in the area of offline-filtration. This is an essential tool for preventive maintenance, either when transferring new oils or purifying existing hydraulic and lubrication oil systems.

The Stauff Portable Filter Cart type SPFC is a very complete and practical unit utilising dual stage filtration 1. pre-filtration through magnetic core 2. final filtration through a 10 micron micro-glass element.

This system is designed for the transfer, draining or filling of reservoirs, or filtration of mineral oil based fluids for hydraulic systems & gear boxes limited to a viscosity range of 10-150 mm²/sec (cSt).

The application of the SPFC offers excellent mobility for maintenance, resulting in clean oil changes, increasing the lifetime of components and a higher availability of machinery.

- Suction/Delivery Hoses: 3/4" ID x 3 m / 9.84 ft (Suction hose fitted with drum lance H: 900mm / 35.43 in)
- Heavy duty frame with solid rubber wheels
- Operation & maintenance manual
- Lockable storage box
- Drip tray
- Hose storage hooks
- Oil resistant rubber handle grips



Type SPFC

- Flow: 23 l/min / 6 US GPM - Nominal
- Voltage: 240 V / 50 Hz
- Start/Stop station with 3 m / 9.84 ft cable
- Electric motor: 1450 RPM 0,55 KW
- Pump: Gear type 23 LPM @ 1450 RPM
- Filter: Magnetic Core (integral pre-filter)
- Element: 10 µm
- Bypass valve opens @ 1,5 bar / 18.12 PSI
- Seals/O-rings: Buna-N® Rubber
- Clogging Indicator: Clean ΔP= 1,25 bar / 18.12 PSI
- Weight: 53 kg / 117 lbs
- Dimensions (H x W x D): 1300 x 620 x 500 mm / 51.18 x 24.40 x 19.68 in

Product-Specific Abbreviations

212 - 213

Product-Specific Abbreviations

Abbreviation	Product Category	Product Description	Page
BPS	Offline and Bypass Filters	Bypass Filters	199
HI	Pressure Filters	Clogging Indicator for Pressure Filters	54
HIM	Pressure Filters	Clogging Indicator for SMPF Series	63
HVB	Pressure Filters	Bypass valve	53
HVM	Pressure Filters	Multi-function valve	53
HVN	Pressure Filters	Non-return valve	53
HVO	Pressure Filters	Non-bypass standard insert	53
HVR	Pressure Filters	Reverse flow valve	53
Limit-Switch	Return-Line Filters	Electrical Clogging Switch for RF Series	73
Limit-Switch	Return-Line Filters	Electrical Clogging Switch for RFA Series	81
Limit-Switch	Return-Line Filters	Electrical Clogging Switch for RFB Series	89
Limit-Switch	Return-Line Filters	Electrical Clogging Switch for RFS Series	99
Limit-Switch	Return-Line Filters	Electrical Clogging Switch for RTF Series	125
Limit-Switch	Spin-On Filters	Electrical Clogging Switch for Spin-On Filters	177
OLS	Offline and Bypass Filters	Offline Filters	183
OLSH	Offline and Bypass Filters	Heated Offline Filters	195
OLSW	Offline and Bypass Filters	Water Absorbing Offline Filters	189
RA	Replacement Filter Elements for Applications involving Hydraulic and Lubrication Oils	Filter Elements for Return-Line Filters	122
RE-014	Replacement Filter Elements for Applications involving Hydraulic and Lubrication Oils	Filter Elements for Return-Line Filters	72
RE-022	Replacement Filter Elements for Applications involving Hydraulic and Lubrication Oils	Filter Elements for Return-Line Filters	88
RE-030	Replacement Filter Elements for Applications involving Hydraulic and Lubrication Oils	Filter Elements for Return-Line Filters	80
RE-045	Replacement Filter Elements for Applications involving Hydraulic and Lubrication Oils	Filter Elements for Return-Line Filters	98
REA	Return-Line Filters	Air Filter Element for RFB Series	88
REL	Replacement Filter Elements	Filter Elements for In-Line Filters SRFL-SW Series	146
RF	Return-Line Filters	Return-Line Filters for Tank-Top Mounting	69
RFA	Return-Line Filters	Return-Line Filters for Tank-Top Mounting	77
RFB	Return-Line Filters	Return-Line Filters for Tank-Top Mounting	85
RFS	Return-Line Filters	Return-Line Filters for Tank-Top Mounting	93
RFS-D	Return-Line Filters	Return-Line Filters for Tank-Top Mounting	93
RTE-20	Replacement Filter Elements for Applications involving Hydraulic and Lubrication Oils	Filter Elements for Return-Line Filters	110
RTE-25	Replacement Filter Elements for Applications involving Hydraulic and Lubrication Oils	Filter Elements for Return-Line Filters	106
RTE-47	Replacement Filter Elements for Applications involving Hydraulic and Lubrication Oils	Filter Elements for Return-Line Filters	112
RTE-48	Replacement Filter Elements for Applications involving Hydraulic and Lubrication Oils	Filter Elements for Return-Line Filters	114/112
RTE-49	Replacement Filter Elements for Applications involving Hydraulic and Lubrication Oils	Filter Elements for Return-Line Filters	112
RTE-58	Replacement Filter Elements for Applications involving Hydraulic and Lubrication Oils	Filter Elements for Return-Line Filters	118
RTEA	Return-Line Filters	Air Filter Element for RTF-20 Series	110
RTF-10/15/25	Return-Line Filters	Return-Line Filters for Tank-Top Mounting	103
RTF-20	Return-Line Filters	Return-Line Filters for Tank-Top Mounting	107
RTF-40	Return-Line Filters	Return-Line Filters for Tank-Top Mounting	111
RTF-50	Return-Line Filters	Return-Line Filters for Tank-Top Mounting	115
RTF-N	Return-Line Filters	Return-Line Filters for In-Tank Mounting	119
SAF-05 / 06 / 07 / 11	Spin-On Filters	Spin-On Filter Heads	153
SAF-10 / 13	Spin-On Filters	Spin-On Filter Heads	154
SBK	Replacement Filter Elements for Single, Double and Automatic Filters	Star-Pleated Elements, Basket and Ring Sieves	32
SBM	Replacement Filter Elements for Single, Double and Automatic Filters	Multimantle Elements	33
SBS	Replacement Filter Elements for Single, Double and Automatic Filters	Star-Pleated Elements, Basket and Ring Sieves	32
SBS-124	Replacement Filter Elements for Single, Double and Automatic Filters	Paper, Fibreglass and Polyester Elements	33
SCFC	Filtration Systems	Filtration Systems STAUFF America	209
SE	Replacement Filter Elements for Applications involving Hydraulic and Lubrication Oils	Filter Elements for High Pressure Filters	40/44/48/52
SF	Pressure Filters	High Pressure Filters (Inline)	37
SF-63	Spin-On Filters	Spin-On Filter Elements	171
SF-65	Spin-On Filters	Spin-On Filter Elements	172
SF-67	Spin-On Filters	Spin-On Filter Elements	173
SFA	Pressure Filters	Medium Pressure Filters (Inline)	49
SFC-35 / 36	Spin-On Filters	Spin-On Filter Elements	169
SFC-57 / 58	Spin-On Filters	Spin-On Filter Elements	170
SFCT-35 / 36	Spin-On Filters	Spin-On Filter Elements	169
SFCT-57 / 58	Spin-On Filters	Spin-On Filter Elements	170
SFK	Replacement Filter Elements for Single, Double and Automatic Filters	Screw-In and Plug-In Elements	32
SFK-320	Replacement Filter Elements for Single, Double and Automatic Filters	Plastic Elements	33
SFK-439	Replacement Filter Elements for Single, Double and Automatic Filters	Heavy Fuel Elements	32
SFK-445	Replacement Filter Elements for Single, Double and Automatic Filters	Plastic Elements	33
SF-TM	Pressure Filters	High Pressure Filters (Top-mounted)	41
SFZ	Pressure Filters	High Pressure Filters (Sandwich)	45

Product-Specific Abbreviations

Abbreviation	Product Category	Product Description	Page
SLF-02 / 03 / 04	Spin-On Filters	Spin-On Filter Head	152
SME	Replacement Filter Elements for Applications involving Hydraulic and Lubrication Oils	Filter Elements for Medium Pressure Filters	62
SMFS	Filtration Systems	Filtration Systems STAUFF Europe	208
SMPF	Pressure Filters	Medium Pressure Filters (Inline)	59
SPFC	Filtration Systems	Filtration Systems STAUFF Australia and New Zealand	209
SPFC-10	Filtration Systems	Filtration Systems STAUFF America	209
SPG-C	Return-Line Filters	Visual Clogging Indicator for RF Series	73
SPG-C	Return-Line Filters	Visual Clogging Indicator for RFA Series	81
SPG-C	Return-Line Filters	Visual Clogging Indicator for RFB Series	89
SPG-C	Return-Line Filters	Visual Clogging Indicator for RFS Series	99
SPG-C	Return-Line Filters	Visual Clogging Indicator for RTF Series	125
SPG-C	Spin-On Filters	Visual Clogging Indicator for Spin-On Filters	177
SRFL-D	In-Line Filters	In-Line Filters - Duplex Housing	129
SRFL-S	In-Line Filters	In-Line Filters - Simplex Housing	129
SRFL-SW	In-Line Filters	In-Line Filters for Industrial Water	143
SRM	Replacement Filter Elements	Filter Elements for Offline and Bypass Filters	181/188/ 194/198/ 201
SSF-100 / 120 / 120L / 130 / 160	Spin-On Filters	Spin-On Filter Heads	157
SSF-12	Spin-On Filters	Spin-On Filter Head	155
SSF-150 / 180	Spin-On Filters	Spin-On Filter Heads	158
SSF-20L	Spin-On Filters	Spin-On Filter Head	156
SSF-24B	Spin-On Filters	Double Spin-On Filter Head	159
SSF-24N / 24S	Spin-On Filters	Double Spin-On Filter Heads	160
SSF-25	Spin-On Filters	Double Spin-On Filter Head	163
SSF-25B	Spin-On Filters	Double Spin-On Filter Head	161
SSF-25FM	Spin-On Filters	Double Spin-On Filter Head	162
SSFT-12	Spin-On Filters	Tank Top Spin-On Filter Head	165
SSFT-12B	Spin-On Filters	Tank Top Spin-On Filter Head	164
SSFT-20	Spin-On Filters	Tank Top Spin-On Filter Head	167
SSFT-20B	Spin-On Filters	Tank Top Spin-On Filter Head	166
WR-40	Return-Line Filters	Weld Ring for RTF-40 Series	113

